



# IKO

## Linear Motion Technology

*for the professional designer*



# IKO

Innovation, Know-how & Originality

IKO Clean Lubrication



CAT-5507.1

# INDEX OF DEMENSION TABLES

# A

## C-Lube Maintenance Free Series

ML.....	A-10	MH.....	A-54	MX.....	A-88
MLF.....	A-14	MHT.....	A-56	MXD.....	A-92
		MHD.....	A-58	MXS.....	A-94
ME.....	A-28	MHS.....	A-60	MXN.....	A-96
MET.....	A-32			MXNS.....	A-98
MES.....	A-36	MUL.....	A-68		
				MAG.....	A-100
				MAGF.....	A-102

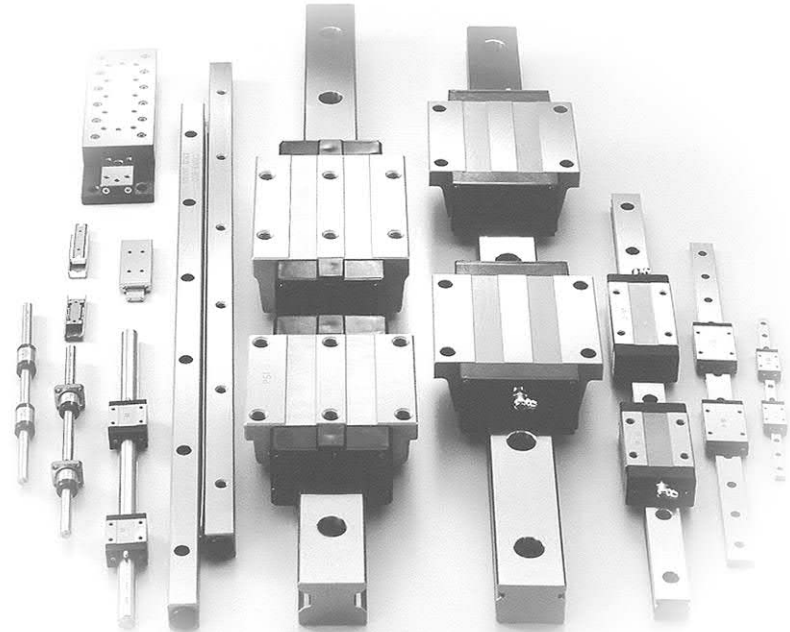

# B

## Linear Way Series

LWL.....	B-16	LWH...B.....	B-94	LWU...B.....	B-138
LWLF.....	B-24	LWHT...B.....	B-98	LWU.....	B-140
		LWHD...B.....	B-102		
LWE.....	B-44	LWHS...B.....	B-106	LWLM.....	B-148
LWET.....	B-48	LWHY.....	B-108	LWM.....	B-150
LWES.....	B-52				
		LWFH.....	B-124		
LWE...Q.....	B-68	LWFF.....	B-126		
LWET...Q.....	B-70	LWFS.....	B-128		
LWES...Q.....	B-72				

# C

## Linear Roller Way Series

LRX.....	C-22
LRXD.....	C-26
LRXS.....	C-32

# D

## Linear Ball Spline Series

LSAG.....	D-38	LSB.....	D-52
LSAGF.....	D-42	LS.....	D-58

# E

## Crossed Roller Way

CRWG.....	E-16	CRW.....	E-50
CRWUG.....	E-24	CRWM.....	E-66
		CRWU.....	E-78
		CRWU...R.....	E-84
		CRWU...RS.....	E-88

## Precision Linear Slide

BWU.....	E-100
BSP.....	E-112
BSPG.....	E-114
BSR.....	E-116

## Linear Bushing

LMG.....	E-128
LBE.....	E-140
LBD.....	E-144
LBB.....	E-148

LM.....	E-152
LME.....	E-160
LMB.....	E-164
LK.....	E-177
LMS.....	E-185

## Stroke Rotary Bushing

ST.....	E-194
STSI.....	E-205
BG.....	E-211

## Flat Roller Cage

FT.....	E-224
FTW.....	E-225

C-Lube Maintenance Free

Linear Way

Linear Roller Way

Linear Ball Spline

Crossed Roller Way

Precision Linear Slide

Linear Bushing

Stroke Rotary Bushing

Flat Roller Cage

Application Examples and Miscellaneous Tables

ML	A			
ME	A			
MH	A			
MUL	A			
MX	A			
MAG	A			
LWL	B			
LWE	B			
LWE...Q	B			
LWH...B	B			
LWFH	B			
LWU...B	B			
LWLM	B			
LRX	C			
LSAG	D			
LSB	D			
CRWG	CRWUG	E		
CRW	CRWU	E		
BWU	BSP, BSPG, BSR	E		
LMG	LBE	LK	LMS	E
ST	STSI	BG	E	
FT	E			
F				

We recognize that the conservation of the global environment as the top-priority challenge to all human being and will help fostering a rich global environment through its activities with the considerations to the environment and reducing negative impacts on the environment as its corporate social responsibility.



*Friendly to Maintenance*  
*Gentle to the Earth*

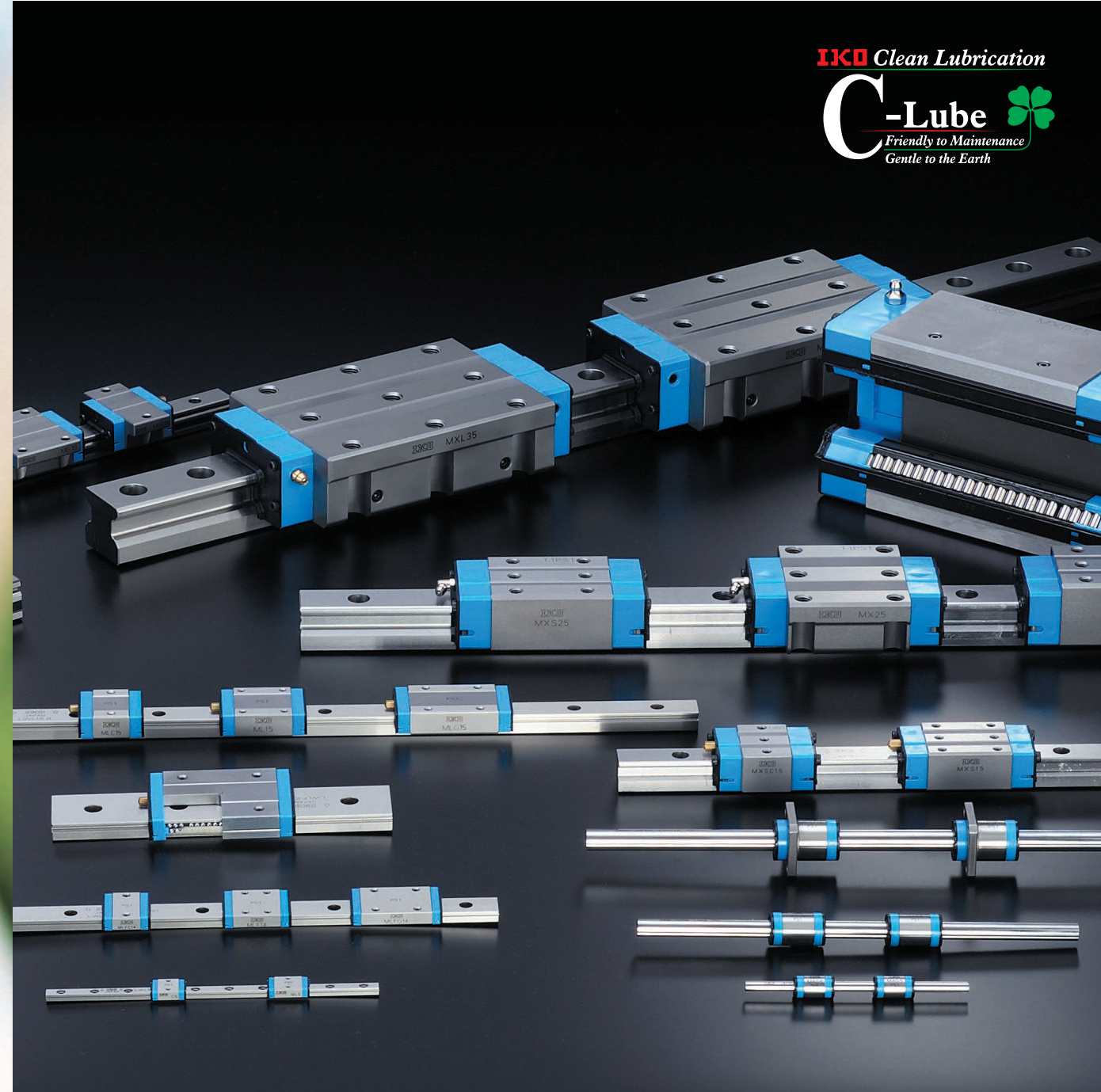

# IKO

## LINEAR MOTION ROLLING GUIDES

CAT-5507.1

**IKO** Linear Motion Rolling Guides are produced at a quality level approved by **ISO-14001** and **ISO-9001** using a production system that reduces negative impact on the global environment.

This catalog adopts the **SI** system (system of international units) in conformance with **ISO** (International Organization for Standardization) Standard 1000. The specifications and dimensions of products in this catalog are subject to change without prior notice.

---

In the table of dimensions, standard products are referred to using identification numbers marked with  . The identification numbers marked with  refer to our semi-standard products.

## GENERAL DESCRIPTION

Advantages of Linear Motion Rolling Guides	6
Features of IKO Linear Motion Rolling Guides	7
Features of IKO Interchangeable Specification Products	8
Types of IKO Linear Motion Rolling Guides	10
Outline of Linear Motion Rolling Guide Selection Procedure	18
Basic Dynamic Load Rating and Life	20
Basic Static Load Rating and Static Safety Factor	23
Equivalent Load	25
Applied Load	29
Preload	44
Friction	45
Lubrication	47
Operating Environment	49

## LINEAR WAY and LINEAR ROLLER WAY

### DESCRIPTION

Features of Linear Way and Linear Roller Way	52
Features of Linear Way	54
Features of Linear Roller Way	56
Series of Linear Way and Linear Roller Way	58
Interchangeable Specification	60
Long-Term Maintenance Free Linear Motion Rolling Guide Series	64
Stainless Series	68
Linear Way and Linear roller way for Special Environment	70
Identification Number	78
For Ordering	79
Load Rating	80
Accuracy	81
Preload	86
Special Specifications	88
Lubrication and Dust Protection	98
Precautions for Use	110
Precautions for Mounting	125
Mounting Examples	128

### A

C-Lube Linear Way ML	ML · MLF	A-2
C-Lube Linear Way ME	ME · MET · MES	A-18
C-Lube Linear Way MH	MH · MHT · MHD · MHS	A-40
C-Lube Linear Way MUL	MUL	A-62
C-Lube Linear Roller Way Super MX	MX · MXD · MXS · MXN · MXNS	A-70
C-Lube Linear Ball Spline MAG	MAG · MAGF	A-100

### B

Linear Way L	LWL · LWLF	B-2
Linear Way E	LWE · LWET · LWES	B-30
Low Decibel Linear Way E	LWE··Q · LWET··Q · LWES··Q	B-56
Linear Way H	LWH··B · LWHT··B · LWHD··B · LWHS··B · LWHY	B-74
Linear Way F	LWFH · LWFF · LWFS	B-110
Linear Way U	LWU	B-130
Linear Way Module	LWLM · LWM	B-142

### C

Linear Roller Way Super X	LRX · LRXD · LRXS	C-2
---------------------------	-------------------	-----

## LINEAR BALL SPLINE

### DESCRIPTION

### D

Features of Linear Ball Spline	D-2	
Series	D-3	
Interchangeable Specification	D-4	
Identification Number	D-6	
For Ordering	D-7	
Load Rating	D-8	
Accuracy	D-11	
Preload	D-15	
Special Specifications	D-16	
Lubrication and Dust Protection	D-18	
Precautions for Use	D-21	
Precautions for Mounting	D-24	
Liner Ball Spline G	LSAG · LSAGF	D-28
Block type Linear Ball Spline	LSB	D-46
Stroke Ball Spline LS	LS	D-54

## OTHER LINEAR MOTION ROLLING GUIDES

### E

Anti-Creep Cage Crossed Roller Way	CRWG	E-2
Anti-Creep Cage Crossed Roller Way Unit	CRWUG	E-18
Crossed Roller Way	CRW · CRWM	E-26
Crossed Roller Way Unit	CRWU	E-72
High Rigidity Precision Linear Slide Unit	BWU	E-92
Precision Linear Slide	BSP · BSPG · BSR	E-104
Linear Bushing G	LMG	E-120
Linear Bushing	LM · LME · LMB	E-130
Compact Linear Bushing	LK	E-174
Miniature Linear Bushing	LMS	E-178
Stroke Rotary Bushing	ST	E-188
Miniature Stroke Rotary Bushing	STSI	E-198
Stroke Rotary Cage	BG	E-206
Flat Roller Cage	FT · FTW··A	E-214

### F

Application Examples	F-2
Miscellaneous Tables	F-26
CAD Data	F-40
Index of Model Codes	F-42

## General Description

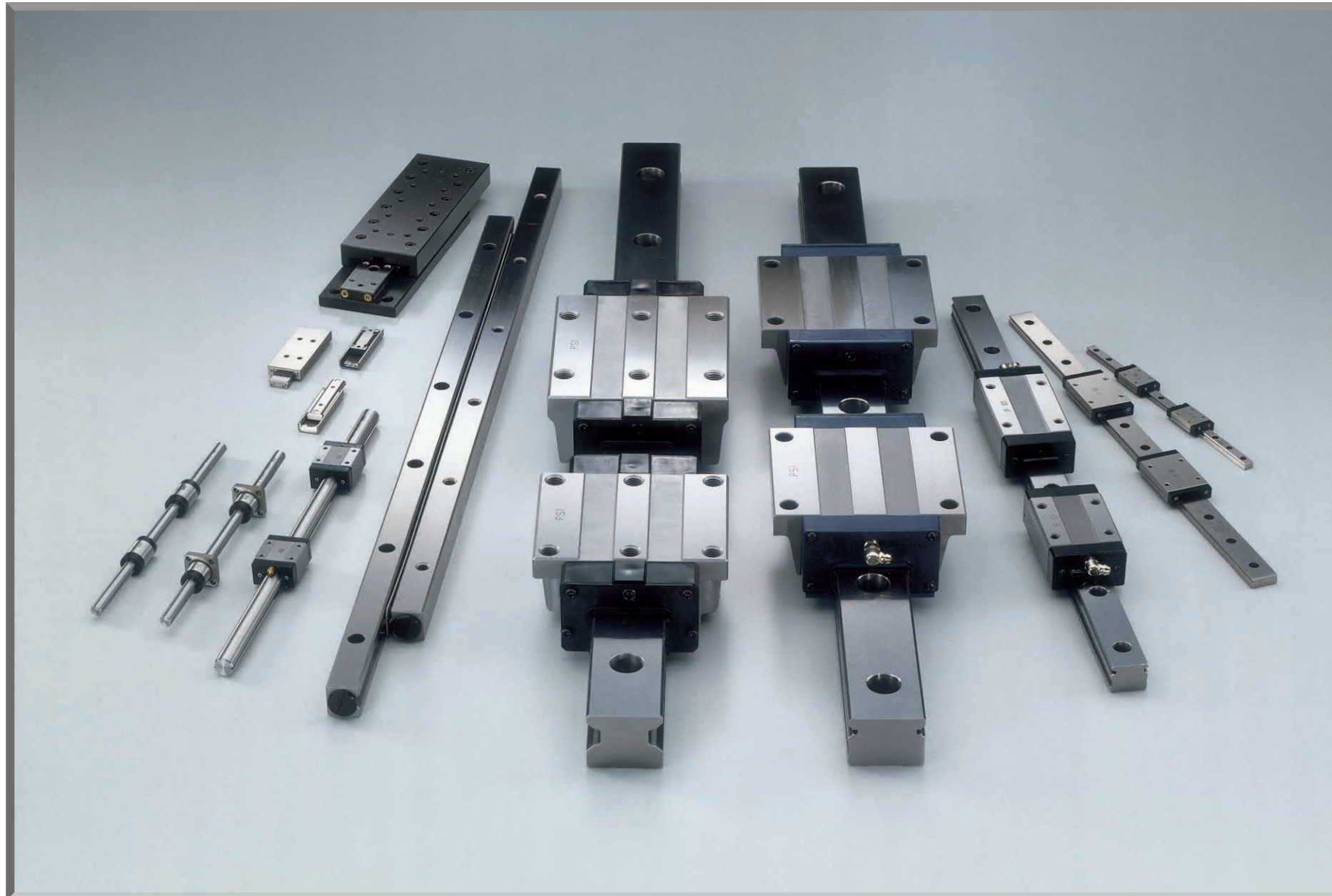

**IKO** Linear Motion Rolling Guides are used with satisfactory results for various applications requiring precision positioning such as semi-conductor manufacturing equipment and large-sized machine tools. In contrast to conventional rolling bearings used in rotating parts, Linear Motion Rolling Guides are the products applicable to plane sliding surfaces, and meet the increasing needs for linear motion and precision positioning in machines and equipment. Linear Way and Linear Roller Way of rail guide type, Linear Ball Spline of shaft guide type, and other products, recognized for their high quality and excellent features, are available.

## Advantages of Linear Motion Rolling Guides

Advantages of Linear Motion Rolling Guides compared with conventional plain guides are as follows.

### 1 High positioning accuracy

Superior response characteristics to micro-feeding and accurate positioning performance can be achieved owing to the stable frictional characteristics of rolling friction with small differences between dynamic and static (start-up) friction and small variations in friction due to velocity changes.

### 2 Reductions in machine size and power consumption

The low frictional resistance allows the use of smaller drive units, which makes it possible to design more compact and lighter machines with less power consumption. So the machine cost and power cost can be saved. In addition, machines can be operated at higher speeds, achieving higher machine efficiency.

### 3 Highly reliable accuracy in long run operations

Owing to very little wear of raceways and rolling elements, high accuracy and reliability of machines and equipment are maintained in long run operations. In addition, the thinner oil films needed to lubricate Linear Motion Rolling Guides in comparison with conventional plain guides reduce errors caused by variations in oil film thickness.

### 4 Improvement of product reliability from first design

Reliability of the machines and equipment is improved from the first stage of the design, because the life of Linear Motion Rolling Guides can be estimated by using the established life calculation formulas based on rolling contact fatigue.

### 5 Simple design for lubrication

In most cases, grease lubrication is sufficient, which requires only a simple design for lubrication and simple maintenance.

### 6 Guide mechanism free from play

By giving a preload, the rigidity of Linear Motion Rolling Guides can be increased and a guide mechanism free from play can be designed. A preloaded rolling guide also achieves smooth motion even without any clearance.

## Features of IKO Linear Motion Rolling Guides

**IKO** Linear Motion Rolling Guides have the following features.

### 1 A choice between ball types and roller types assures the best selection for any application

**IKO** offers two basic design concepts: steel ball types and cylindrical roller types. Steel ball types are most suited for general purpose applications requiring a light to medium load capacity and low frictional resistance. Cylindrical roller types, in comparison, are most often selected for machines needing a high load capacity and very high rigidity.

### 2 A wide selection of various types for all kinds of industrial uses

Suitable designs in rail guide types and shaft guide types as well as limited motion types and endless motion types are all parts of **IKO**'s standard product lines.

### 3 A functional simplicity in structure yields high reliability

**IKO** Linear Motion Rolling Guides feature functional and simple designs. Compared to more complicated designs needing extra steps in manufacturing, the simplicity of **IKO** designs reduce the potential processing errors that might occur during the various stages of production. Mounting errors can also be eliminated.

### 4 Process reductions in designing and assembling

Typical **IKO** Linear Motion Rolling Guides are made into one complete unit of linear motion rolling guide mechanism, and their sizes and accuracy are standardized. Design, assembly and maintenance time of machines and equipment can be reduced greatly by adopting these products.

### 5 Superior performance and high quality through advanced manufacturing techniques

**IKO**'s precision manufacturing technology and quality control have been developed to achieve and maintain an internationally recognized reputation as a manufacturer of top quality needle roller bearings and other precision machine components. This firm commitment to manufacturing excellence is reflected in the superior performance and high quality of **IKO** Linear Motion Rolling Guides.

## Features of IKO interchangeable specification products

Interchangeable specification products are available in Linear Way, Linear Roller Way, and Linear Ball Spline series of **IKO** Linear Motion Rolling Guides. As slide units/external cylinders and track rails/spline shafts of these products are interchangeable, product selection can be made more freely and easily meeting the customer's needs.

### 1 Easy addition and replacement of parts

Slide units/external cylinders can be added or replaced on a track rail/spline shaft as required, and even slide units/external cylinders of different types can be assembled on a same track rail/spline shaft. When replacement of parts must be made urgently, for example, due to a design change, it can be made without delay.

### 2 Short delivery term

As slide units/external cylinders and track rails/spline shafts are stocked separately, these parts can be delivered promptly.

### 3 High accuracy and high preload

Interchangeability is achieved by rigorous accuracy control of individual parts. As a result, one-step higher accuracy and preload can be offered.

### 4 Improved efficiency at assembly work

Interchangeable specification products can be assembled without specially selecting slide units/external cylinders and track rails/spline shafts for assembly. So efficiency at assembly work can be improved.

### 5 A wide range of variations

A wide range of variations in types, sizes, materials, etc. are available, so an optimum product can be selected by the customer for each application.

### 6 Special specifications

Standard products are available with abundant optional special specifications to meet the diversified needs. These special specification products can be ordered by simply adding the supplemental code to the end of the identification number.

**IKO** proposes interchangeable specification Linear Motion Rolling Guides for free and easy product selection by the user.

## Line-up of interchangeable specification products

	Rolling element	Series name	Material	Variation	Reference page	
<b>C-Lube Maintenance Free series</b>	Ball	C-Lube Linear Way ML	Stainless steel	6 types, 37 sizes	A-2 ~	
		C-Lube Linear Way ME	Carbon steel	9 types, 45 sizes	A-18 ~	
		C-Lube Linear Way MH	Carbon steel	8 types, 40 sizes	A-34 ~	
			Stainless steel	4 types, 12 sizes		
	Roller	C-Lube Linear Roller Way Super MX	High Carbon steel	13 types, 75 sizes	A-70 ~	
Ball	C-Lube Linear Ball Spline MAG	High Carbon steel	4 types, 20 sizes	A-100 ~		
<b>Linear Way series</b>	Ball	Linear Way L	High carbon steel	2 types, 8 sizes	B-2 ~	
			Stainless steel	6 types, 38 sizes		
	Ball	Linear Way E	High carbon steel	9 types, 45 sizes	B-30 ~	
			Stainless steel	9 types, 36 sizes		
	Ball	Linear Way H	High carbon steel	8 types, 52 sizes	B-74 ~	
			Stainless steel	6 types, 24 sizes		
	Ball	Linear Way F	High carbon steel	3 types, 9 sizes	B-110 ~	
			Stainless steel	1 type, 3 sizes		
	<b>Linear Roller Way series</b>	Roller	Linear Roller Way Super X	High carbon steel	9 types, 69 sizes	C-2 ~
				Stainless steel	3 types, 15 sizes	
<b>Linear Ball Spline series</b>	Ball	Linear Ball Spline G	High carbon steel	8 types, 56 sizes	D-28 ~	
			Stainless steel	1 type, 3 sizes		
		Block type Linear Ball Spline	High carbon steel	2 types, 14 sizes	D-46 ~	
Stainless steel	1 type, 3 sizes					



## Types of IKO Linear Motion Rolling Guides

**IKO** Linear Motion Rolling Guides are classified according to the guide type, motion type and rolling element type. Three guide types, namely, rail guide type, shaft guide type and flat guide type are available. Each of them is divided into the endless motion type in which rolling elements are re-circulated to achieve endless linear motion and the limited motion type without rolling element re-circulation. These types are divided again into ball types and roller types. Each of these guides has its own features.

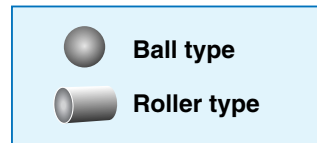

### Rail guide type

The rail guide type achieves linear motion along a rail. This product can receive a complex load and features high performance, excellent total balance and easy handling.

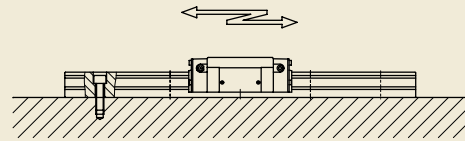

#### Endless linear motion

##### Linear Way

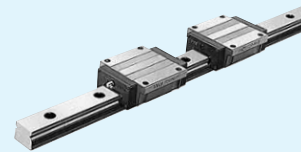

##### Linear Roller Way

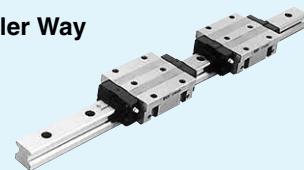

#### Limited linear motion

##### Crossed Roller Way

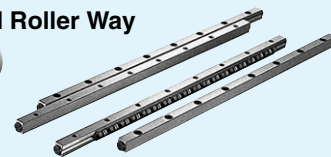

##### Precision Linear Slide



### Shaft guide type

The shaft guide type achieves linear motion along a shaft. This product is easy to handle and suitable for relatively low load conditions. Some shaft guide products can achieve both rotation and reciprocating linear motion.

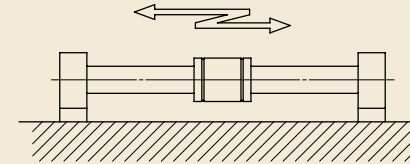

#### Endless linear motion

##### Linear Ball Spline

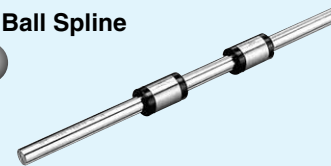

##### Linear Bushing



#### Limited linear motion and rotation

##### Stroke Rotary Bushing











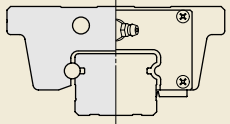

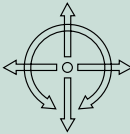
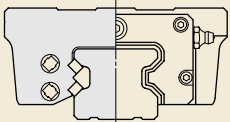
## Rail guide type

Rail guide type linear motion rolling guides are easy to mount and can receive complex loads. Man-hours for mounting them on machines and equipment and for designing the guide mechanism can be saved, and consequently the overall machine cost can be reduced greatly. Linear Roller Way can be used for applications subjected to a large load and Linear Way for general-purpose applications.

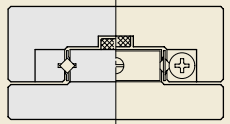
For applications with a relatively small load requiring smooth and precise motion, use Crossed Roller Way or Precision Linear Slide.

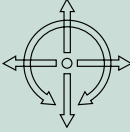
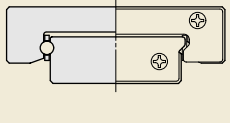
## Rail guide type

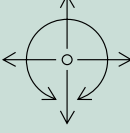





		Type of rolling element	Type of motion		Load direction and load carrying capacity	Rigidity	Frictional characteristic	Ease of mounting	General applications	
Endless linear motion	<b>Linear Way</b> 	 Ball	 Endless linear motion		 Complex load, medium to heavy load	○	○	◎	<ul style="list-style-type: none"> <li>NC machine tool</li> <li>Precision working machine</li> <li>Robot</li> <li>Material transfer machine</li> </ul>	Page A-2~ Page B-2~
	<b>Linear Roller Way</b> 	 Roller	 Endless linear motion		 Complex load, heavy to extra-heavy load	◎	○	◎	<ul style="list-style-type: none"> <li>Heavy duty machine tool</li> <li>Large working machine</li> <li>High-rigidity robot</li> </ul>	Page C-2~
Limited linear motion	<b>Crossed Roller Way</b> 	 Roller	 Limited linear motion		 Complex load, medium load	○	◎	◎	<ul style="list-style-type: none"> <li>Precision working machine</li> <li>Electronic parts assembling machine</li> <li>Precision measuring instrument</li> </ul>	Page E-2~
	<b>Precision Linear Slide</b> 	 Ball	 Limited linear motion		 Complex load, light to medium load	△	◎	◎	<ul style="list-style-type: none"> <li>Electronic parts assembling machine</li> </ul>	Page E-92~

Remarks: ◎ Excellent, ○ Good, △ Fair

## Shaft Guide Type

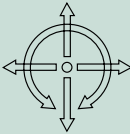
Shaft guide type linear motion rolling guides feature easy mounting. These guides can be used to reduce man-hours for mounting them on machines and equipment, and consequently to save greatly the overall system cost. Stroke Rotary Bushings make both linear reciprocating motion and rotation and can be used on rotary shafts. Linear Ball Splines can be used as rotary shafts to transmit torque when combined with shaft support bearings.

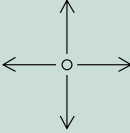
## Shaft Guide Type

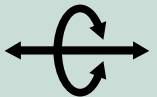
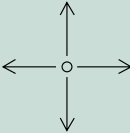
		Type of rolling element	Type of motion		Load direction and load carrying capacity	Rigidity	Frictional characteristic	Ease of mounting	General applications	
<b>Endless linear motion</b>	<b>Linear Ball Spline</b>	 Ball	 Endless linear motion		 Complex load, medium to heavy load	○	○	○	<ul style="list-style-type: none"> <li>• Robot</li> <li>• Testing and inspection equipment</li> <li>• Material transfer machine</li> </ul>	Page D-28-
	<b>Linear Bushing</b>	 Ball	 Endless linear motion		 Radial load, light load	△	○	○	<ul style="list-style-type: none"> <li>• Packaging machine</li> <li>• Measuring instrument</li> <li>• Medical equipment</li> </ul>	Page E-120-
<b>Limited linear motion + rotation</b>	<b>Stroke Rotary Bushing</b>	 Ball	 Limited linear motion + rotation		 Radial load, light load	△	◎	○	<ul style="list-style-type: none"> <li>• Printing press</li> <li>• Press die set</li> <li>• Precision measuring instrument</li> </ul>	Page E-188-

Remarks: ◎ Excellent, ○ Good, △ Fair

## Flat Guide Type

Flat guide type linear motion rolling guides can receive only a uni-directional load but feature high rigidity in the load direction. A guide surface must be prepared for these rolling guides by surface hardening such as heat treatment and precision surface finishing.

## Flat Guide Type

		Type of rolling element	Type of motion		Load direction and load carrying capacity	Rigidity	Frictional characteristic	Ease of mounting	General applications	
Limited linear motion	Flat Roller Cage	Roller	Limited linear motion		One-directional load, extra-heavy load	◎	◎	○	<ul style="list-style-type: none"> <li>Precision working machine</li> <li>Optical measuring instrument</li> </ul>	Page E-230-
	Remarks: ◎ Excellent, ○ Good, △ Fair									

## Outline of Linear Motion Rolling Guide Selection Procedure

Selection of an optimum linear motion rolling guide is made with careful consideration on various factors from the basic items to the details.

An example of standard procedure for selection is shown below.

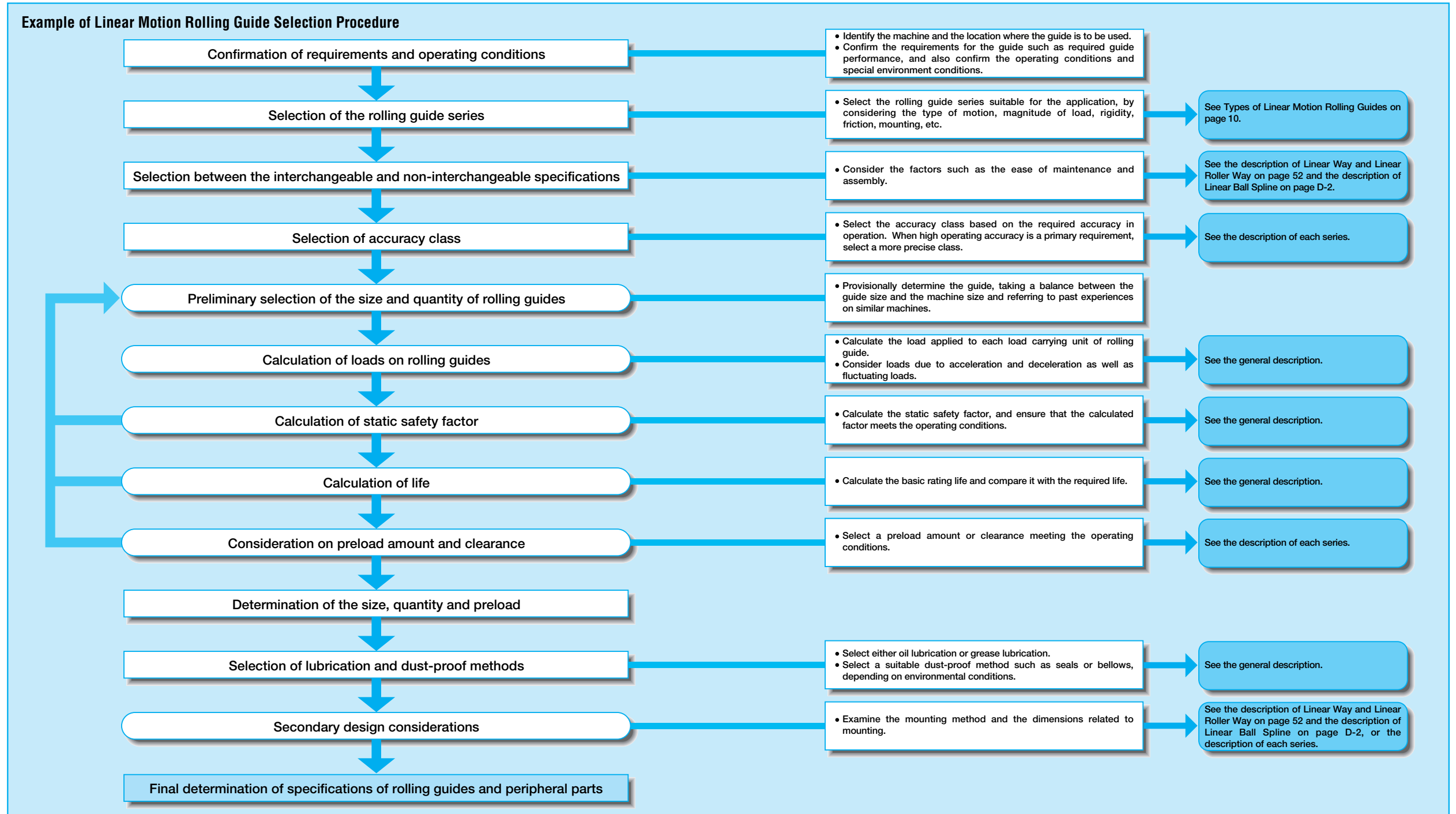

## Basic Dynamic Load Rating and Life

### Life of Linear Motion Rolling Guides

When linear motion rolling guides are operated over a certain period, they will eventually wear out even under normal operating conditions. This is because the raceways and rolling elements of linear motion rolling guides are subjected to repeated loads and will be damaged by rolling contact fatigue of material characterized by the formation of scale-like wear fragments (fatigue flaking). These damaged rolling guides can no longer be used. The life of linear motion rolling guide is defined as the total traveling distance accomplished before the first evidence of fatigue flaking appears on one of the raceways or rolling elements. There is a variation in life because material fatigue is a statistical phenomenon. The basic rating life is therefore calculated statistically.

### Basic dynamic load rating $C$ (Complying with ISO 14728-1)<sup>(1)</sup>

The basic dynamic load rating of linear motion rolling guide is the constant load both in direction and magnitude that gives the basic rating life as shown in Table 1, when a group of identical rolling guides are individually operated.

The basic dynamic load rating may be corrected for the direction of applied load. For details, see the description of each series.

Note<sup>(1)</sup>: This standard is not applicable on some series.

### Rating life

The basic rating life of linear motion rolling guide is defined as the total traveling distance that 90% of a group of identical rolling guides can be operated individually under the same conditions free from any material damage caused by rolling fatigue.

However, the basic rating life of Stroke Rotary Bushing is represented by the total number of revolutions.

Table 1 Basic rating life for basic dynamic load rating

Series	Basic rating life for basic dynamic load rating
Linear Way Linear Roller Way Linear Ball Spline Precision Linear Slide Linear Bushing	$50 \times 10^3$ m
Crossed Roller Way Flat Roller Cage	$100 \times 10^3$ m
Stroke Rotary Bushing	$10^6$ rev.

### Life calculation

#### Life calculation formula

Table 2 shows the relationship between the basic rating life, basic dynamic load rating and applied load of the linear motion rolling guides.

In the life calculation for practical applications, load factor, temperature factor, hardness factor, etc. are taken into consideration. See Table 3 for Stroke Rotary Bushing.

Table 2 Applicable life calculation formula

Series	Basic rating life calculation formula		Symbols
	unit : $10^3$ m	unit : hours	
Linear Way Precision Linear Slide Linear Bushing	$L = 50 \left(\frac{C}{P}\right)^3$	$L_h = \frac{10^6 L}{2S n_1 \times 60}$	$L$ : Basic rating life, $10^3$ m $C$ : Basic dynamic load rating, N $T$ : Dynamic torque rating, N·m $P$ : Dynamic equivalent load (or applied load), N $M$ : Applied torque, N·m $L_h$ : Basic rating life in hours, h $S$ : Stroke length, mm $n_1$ : Number of strokes per minute, cpm
Linear Ball Spline	$L = 50 \left(\frac{C}{P}\right)^3$ $L = 50 \left(\frac{T}{M}\right)^3$		
Linear Roller Way	$L = 50 \left(\frac{C}{P}\right)^{10/3}$		
Crossed Roller Way Flat Roller Cage	$L = 100 \left(\frac{C}{P}\right)^{10/3}$		

Table 3 Life calculation formula of Stroke Rotary Bushing

Type of motion	Basic rating life calculation formula		Symbols
	unit : $10^6$ rev.	unit : hours	
Rotation	$L = \left(\frac{C}{P}\right)^3$	$L_h = \frac{10^6 L}{60\sqrt{(D_{pw} n)^2 + (10S n_1)^2}/D_{pw}}$	$L$ : Basic rating life, $10^6$ rev. $C$ : Basic dynamic load rating, N $P$ : Applied load, N $L_h$ : Basic rating life in hours, h $n$ : Rotation speed, rpm $n_1$ : Number of strokes per minute, cpm $S$ : Stroke length, mm $D_{pw}$ : Pitch diameter of ball set, mm ( $D_{pw} \approx 1.15F_w$ ) $F_w$ : Diameter of inscribed circle, mm
Combined motion of rotation and reciprocating linear motion			
Reciprocating linear motion		$L_h = \frac{10^6 L}{600S n_1/\pi D_{pw}}$	

## Temperature factor

Since the allowable contact stress of rolling guides will gradually decrease when the operating temperature of the rolling guide rises over 150°C, the basic dynamic load rating must be corrected for temperature.

$$C_t = f_t C \quad \text{..... (1.1)}$$

where,  $C_t$  : Basic dynamic load rating considering a temperature rise, N

$f_t$  : Temperature factor (See Fig. 1.)

$C$  : Basic dynamic load rating, N

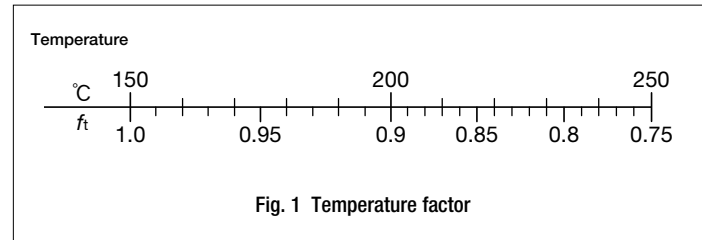

Fig. 1 Temperature factor

## Hardness factor

The raceway surface hardness must be 58 to 64HRC. When the hardness is lower than 58HRC, the basic dynamic load rating must be corrected by the following formula.

$$C_H = f_H C \quad \text{..... (1.2)}$$

where,  $C_H$  : Basic dynamic load rating considering hardness, N

$f_H$  : Hardness factor (See Fig. 2.)

$C$  : Basic dynamic load rating, N

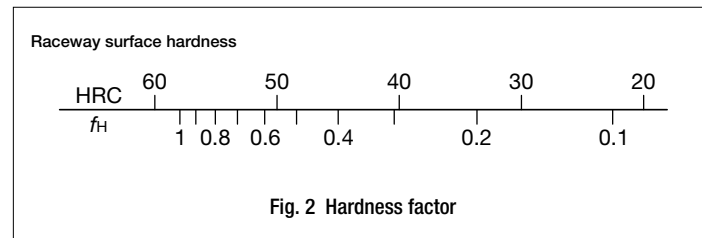

Fig. 2 Hardness factor

## Basic Static Load Rating and Static Safety Factor

### Basic static load rating $C_0$ (Complying with ISO 14728-2)<sup>(1)</sup>

The basic static load rating of linear motion rolling guide is defined as the static load which gives the contact stress as shown in Table 4 at the center of the contact area between the rolling element and the raceway receiving the maximum load.

If a large load or a heavy shock is applied to a rolling guide when it is stationary or running at a relatively low speed, a local permanent deformation may be made on the rolling elements and/or the raceway surfaces of the slide unit, track rail, external cylinder, shaft, etc. When this permanent deformation becomes larger than a certain size, it will prevent smooth rolling motion and cause the guide to generate noise or vibrate, resulting in degradation in traveling performance and eventually early-stage damage.

The basic static load rating is used in combination with the static safety factor to give the load that may cause the permanent deformation exceeding this limit.

The basic static load rating may be corrected for the applied load direction. For details, see the description of each series.

Note(!) : This standard is not applicable on some series.

Table 4 Maximum contact stress

Series	Maximum contact stress
Linear Way Linear Ball Spline	4 200 MPa
Linear Roller Way Crossed Roller Way Roller Way Flat Roller Cage	4 000 MPa

### Static moment rating

The static moment rating is defined as the static moment which gives the contact stress as shown in Table 4 at the center of the contact area between the rolling element and the raceway receiving the maximum load when the moment shown in the examples of Fig. 3 is applied.

Generally, like the basic static load rating, the static moment rating is used in combination with the static safety factor to give the limiting load for normal rolling motion.

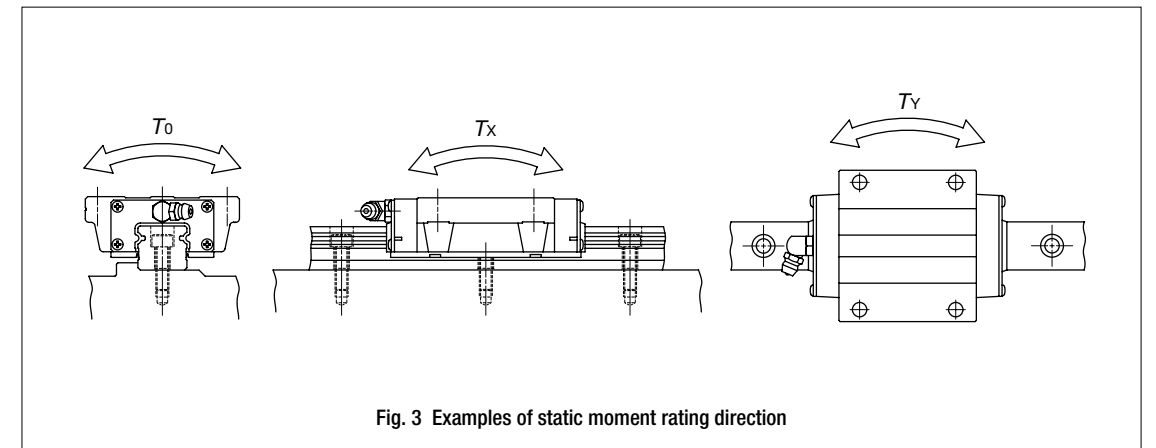

Fig. 3 Examples of static moment rating direction

## ● Static safety factor

The basic static load rating and the static moment rating (or static torque rating) are considered as the theoretical allowable limit of load for normal rolling motion. In practice, this limit must be corrected by the static safety factor considering the operating conditions and performance required of linear motion rolling guides. The static safety factor is obtained by the formulas below, and Tables 5.1 to 5.4 give standard values of this factor. For moment or torque load, the formula (1.4) is a representative formula. The static safety factor is calculated in each direction by applying the static moment rating and the maximum moment in that direction.

$$f_s = \frac{C_0}{P_0} \dots\dots\dots (1.3)$$

$$f_s = \frac{T_0}{M_0} \dots\dots\dots (1.4)$$

where,  $f_s$  : Static safety factor  
 $C_0$  : Basic static load rating, N  
 $P_0$  : Static equivalent load  
 (or applied static load (maximum load)), N  
 $T_0$  : Static moment rating, N·m  
 (or static torque rating)  
 $M_0$  : Moment or torque, N·m  
 (maximum moment or maximum torque)

**Table 5.1 Static safety factor**

Operating conditions	$f_s$
Operation with vibration and/or shocks	3~5
High operating performance	2~4
Normal operation	1~3

Remark : This table does not apply to Linear Roller Way, Linear Ball Spline, Linear Bushing and Stroke Rotary Bushing.

**Table 5.3 Static safety factor of Linear Ball Spline**

Operating conditions	$f_s$
Operation with vibration and/or shocks	5~7
High operating performance	4~6
Normal operation	3~5

Remark : It is recommended to adopt a static safety factor of 5 or more for Angular type Linear Ball Spline.

**Table 5.2 Static safety factor of Linear Roller Way**

Operating conditions	$f_s$
Operation with vibration and/or shocks	4 ~6
High operating performance	3 ~5
Normal operation	2.5~3

**Table 5.4 Static safety factor of Linear Bushing and Stroke Rotary Bushing**

Operating conditions	$f_s$
Operation with vibration and/or shocks	2.5
Quiet operation	2
Normal operation	1.5

## Equivalent Load

### ● Dynamic equivalent load

When a load is applied in a direction other than that of the basic dynamic load rating of Linear Way or Linear Roller Way or a complex load is applied, the dynamic equivalent load must be calculated to obtain the basic rating life.

Obtain the downward and lateral conversion loads from the loads and moments in various directions.

$$F_{re} = k_r |F_r| + \frac{C_0}{T_0} |M_0| + \frac{C_0}{T_x} |M_x| \dots\dots\dots (1.5)$$

$$F_{ae} = k_a |F_a| + \frac{C_0}{T_y} |M_y| \dots\dots\dots (1.6)$$

where,  $F_{re}$  : Downward conversion load, N  
 $F_{ae}$  : Lateral conversion load, N  
 $F_r$  : Downward load, N  
 $F_a$  : Lateral load, N  
 $M_0$  : Moment in the  $T_0$  direction, N·m  
 $M_x$  : Moment in the  $T_x$  direction, N·m  
 $M_y$  : Moment in the  $T_y$  direction, N·m  
 $k_r, k_a$  : Conversion factors for load direction (See Table 7.)  
 $C_0$  : Basic static load rating, N  
 $T_0$  : Static moment rating in the  $T_0$  direction, N·m  
 $T_x$  : Static moment rating in the  $T_x$  direction, N·m  
 $T_y$  : Static moment rating in the  $T_y$  direction, N·m

Obtain the dynamic equivalent load from the downward and lateral conversion loads.

$$P = X F_{re} + Y F_{ae} \dots\dots\dots (1.7)$$

where,  $P$  : Dynamic equivalent load, N  
 $X, Y$  : Dynamic equivalent load factor (See Table 6.)  
 $F_{re}$  : Downward conversion load, N  
 $F_{ae}$  : Lateral conversion load, N

**Table 6 Dynamic equivalent load factor**

Condition	X	Y
$ F_{re}  \geq  F_{ae} $	1	0.6
$ F_{re}  <  F_{ae} $	0.6	1



Table 7 Conversion factor for load direction

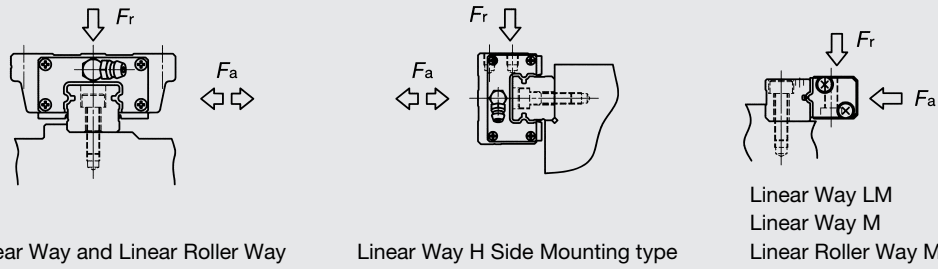

Series and size	Conversion factor		
	$k_r$		$k_a$
	$F_r \geq 0$	$F_r < 0$	
C-Lube Linear Way ML		1	1.19
C-Lube Linear Way ME	15~30	1	1
	35~45	1	1.28
C-Lube Linear Way MH	8~12	1	1.19
	15~30	1	1
C-Lube Linear Way MUL	35~45	1	1.28
		1	1.19
Linear Way L	Ball retained type	1	1.13
	Ball non-retained type	1	0.88
Linear Way E	15~30	1	1
	35~45	1	1.13
Low Decibel Linear Way E		1	1
Linear Way H	8~12	1	1.13
	15~30	1	1
	35~65	1	1.13
	85	1	1.28
Linear Way H Side Mounting type	15~30	1	1
	35~65 (1)	1	0.84 0.95
Linear Way F	33~42	1	1
	69	1	1.13
Linear Way FH		1	1.13
Linear Way U	25, 30	1	1.13
	40~130	1	1
C-Lube Linear Roller Way Super MX		1	1
Linear Roller Way Super X		1	1
Linear Way Module LM		1	0.70
Linear Way Module M	1~ 5	1	1.13
	6	1	1.28

Note(1): The upper value in the  $k_a$  column is the value when the load is applied to the right and the lower value is the value when the load is applied to the left in the above sketch.

Remark :  $F_r$  is the downward load. (When its value is smaller than zero, it is an upward load.)

## Static equivalent load $P_0$

When a load is applied in a direction other than that of the basic static load rating of Linear Way or Linear Roller Way or a complex load is applied, the static equivalent load must be calculated to obtain the static safety factor.

$$P_0 = k_{0r}|F_r| + k_{0a}|F_a| + \frac{C_0}{T_0}|M_0| + \frac{C_0}{T_x}|M_x| + \frac{C_0}{T_y}|M_y| \dots \dots (1.8)$$

- where,
- $P_0$  : Static equivalent load, N
  - $F_r$  : Downward load, N
  - $F_a$  : Lateral load, N
  - $M_0$  : Moment in the  $T_0$  direction, N · m
  - $M_x$  : Moment in the  $T_x$  direction, N · m
  - $M_y$  : Moment in the  $T_y$  direction, N · m
  - $k_{0r}, k_{0a}$  : Conversion factors for load direction (See Table 8.)
  - $C_0$  : Basic static load rating, N
  - $T_0$  : Static moment rating in the  $T_0$  direction, N · m
  - $T_x$  : Static moment rating in the  $T_x$  direction, N · m
  - $T_y$  : Static moment rating in the  $T_y$  direction, N · m

Table 8 Conversion factor for load direction

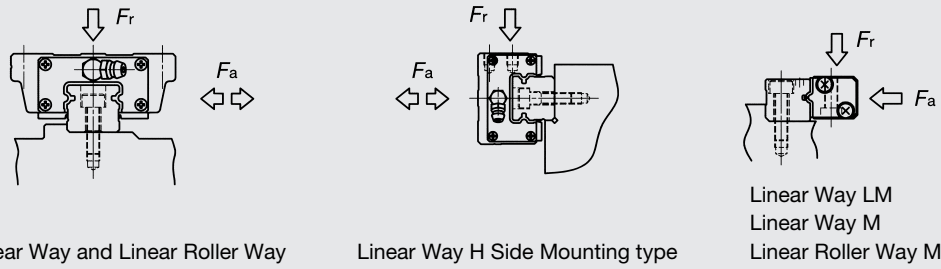

Series and size	Conversion factor		
	$F_r \geq 0$	$F_r < 0$	$k_{0a}$
C-Lube Linear Way ML	1	1	1.19
C-Lube Linear Way ME	15~30	1	1
	35~45	1	1.28
C-Lube Linear Way MH	8~12	1	1.19
	15~30	1	1
C-Lube Linear Way MUL	35~45	1	1.28
		1	1.19
Linear Way L	Ball retained type	1	1
	Ball non-retained type	1	0.84
Linear Way E	15~30	1	1
	35~45	1	1.19
Low Decibel Linear Way E	1	1	1
Linear Way H	8~12	1	1.19
	15~30	1	1
	35~65	1	1.28
	85	1	1.43
Linear Way H Side Mounting type	15~30	1	1
	35~65 (1)	1	0.78 0.93
Linear Way F	33~42	1	1
	69	1	1.19
Linear Way FH	1	1.19	1.28
Linear Way U	25, 30	1	1
	40~130	1	1
C-Lube Linear Roller Way Super MX	1	1	1
Linear Roller Way Super X	1	1	1
Linear Way Module LM	1	1	0.60
Linear Way Module M	1~ 5	1	1.19
	6	1	1.43

Note(1): The upper value in the  $k_{0a}$  column is the value when the load is applied to the right and the lower value is the value when the load is applied to the left in the above sketch.

Remark :  $F_r$  is the downward load. (When its value is smaller than zero, it is an upward load.)

## Applied Load

In some series of Linear Motion Rolling Guides excluding Linear Way and Linear Roller Way, the dynamic load rating and static load rating corrected for the direction of the theoretical applied load are used for calculating the basic rating life and static safety factor. For details, see the description of each series.

### Load factor

Due to vibration and/or shocks during machine operation, the actual load on each rolling guide becomes greater in many cases than the theoretically calculated load. The applied load is generally calculated by multiplying the theoretically calculated load by the load factor indicated in Table 9.

Table 9 Load factor

Operating conditions	$f_w$
Smooth operation free from vibration and/or shocks	1 ~1.2
Normal operation	1.2~1.5
Operation with vibration and/or shocks	1.5~3

## Calculation of load

Table 10.1 to Table 10.6 show calculation examples of the loads applied on Linear Motion Rolling Guides incorporated in machines or equipment.

Table 10.1 One track rail and one slide unit

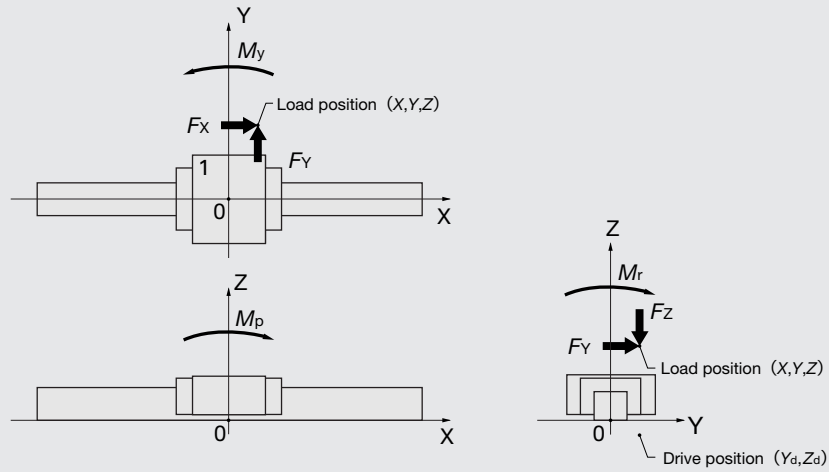

Slide unit No.	Load applied on the slide unit				
	Downward load $F_r$	Lateral load $F_a$	Moment in the $T_0$ direction $M_0$	Moment in the $T_x$ direction $M_x$	Moment in the $T_y$ direction $M_y$
1	$F_z$	$F_y$	$M_r$	$M_p$	$M_y$

Remark : The moment loads in each direction  $M_r$ ,  $M_p$ , and  $M_y$  can be obtained by the following formulae.

$$M_r = F_y Z + F_z Y$$

$$M_p = F_x (Z - Z_d) + F_z X$$

$$M_y = -F_x (Y - Y_d) + F_y X$$

Table 10.2 One track rail and two slide units

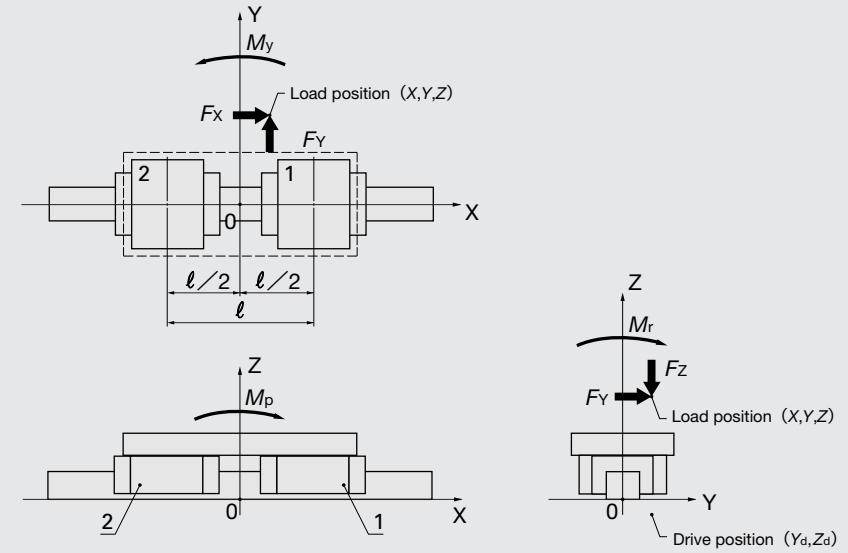

Slide unit No.	Load applied on the slide unit		
	Downward load $F_r$	Lateral load $F_a$	Moment in the $T_0$ direction $M_0$
1	$\frac{F_z}{2} + \frac{M_p}{\ell}$	$\frac{F_y}{2} + \frac{M_y}{\ell}$	$\frac{M_r}{2}$
2	$\frac{F_z}{2} - \frac{M_p}{\ell}$	$\frac{F_y}{2} - \frac{M_y}{\ell}$	$\frac{M_r}{2}$

Remark : The moment loads in each direction  $M_r$ ,  $M_p$ , and  $M_y$  can be obtained by the following formulae.

$$M_r = F_y Z + F_z Y$$

$$M_p = F_x (Z - Z_d) + F_z X$$

$$M_y = -F_x (Y - Y_d) + F_y X$$

Table 10.3 Two track rails and one slide unit on each track rail

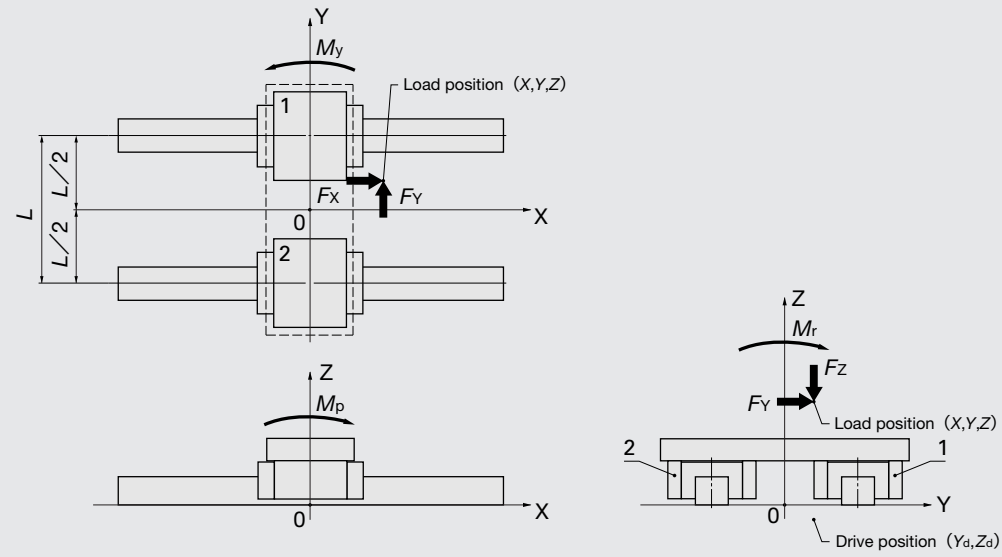

Slide unit No.	Load applied on the slide unit			
	Downward load $F_r$	Lateral load $F_a$	Moment in the $T_x$ direction $M_x$	Moment in the $T_y$ direction $M_y$
1	$\frac{F_z}{2} + \frac{M_r}{L}$	$\frac{F_y}{2}$	$\frac{M_p}{2}$	$\frac{M_y}{2}$
2	$\frac{F_z}{2} - \frac{M_r}{L}$	$\frac{F_y}{2}$	$\frac{M_p}{2}$	$\frac{M_y}{2}$

Remark : The moment loads in each direction  $M_r$ ,  $M_p$ , and  $M_y$  can be obtained by the following formulae.

$$M_r = F_y Z + F_z Y$$

$$M_p = F_x (Z - Z_a) + F_z X$$

$$M_y = -F_x (Y - Y_a) + F_y X$$

Table 10.4 Two track rails and two slide units on each track rail

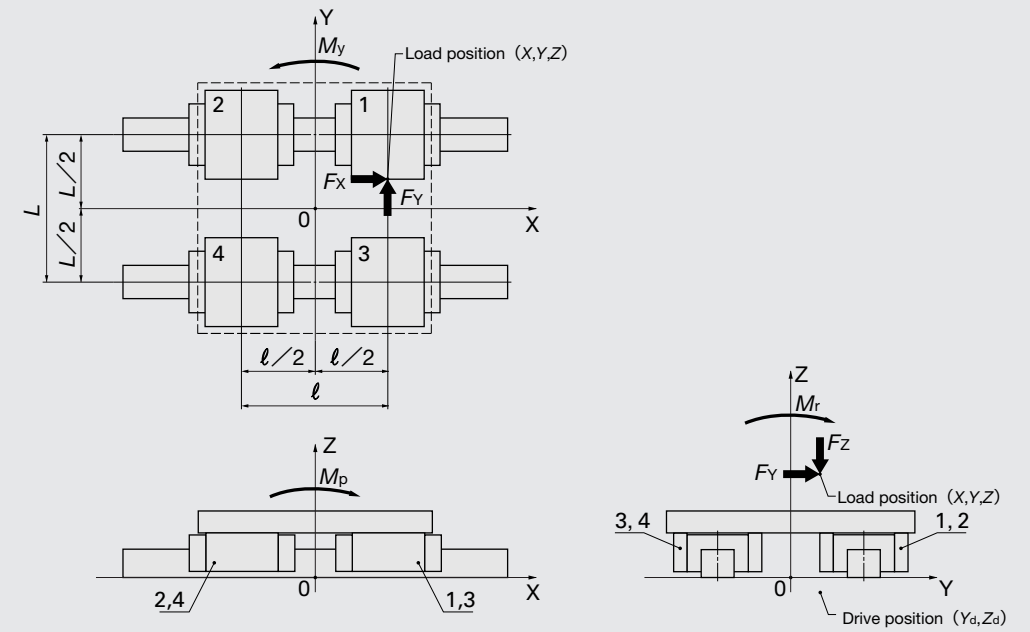

Slide unit No.	Load applied on the slide unit	
	Downward load $F_r$	Lateral load $F_a$
1	$\frac{F_z}{4} + \frac{M_r}{2L} + \frac{M_p}{2\ell}$	$\frac{F_y}{4} + \frac{M_y}{2\ell}$
2	$\frac{F_z}{4} + \frac{M_r}{2L} - \frac{M_p}{2\ell}$	$\frac{F_y}{4} - \frac{M_y}{2\ell}$
3	$\frac{F_z}{4} - \frac{M_r}{2L} + \frac{M_p}{2\ell}$	$\frac{F_y}{4} + \frac{M_y}{2\ell}$
4	$\frac{F_z}{4} - \frac{M_r}{2L} - \frac{M_p}{2\ell}$	$\frac{F_y}{4} - \frac{M_y}{2\ell}$

Remark : The moment loads in each direction  $M_r$ ,  $M_p$ , and  $M_y$  can be obtained by the following formulae.

$$M_r = F_y Z + F_z Y$$

$$M_p = F_x (Z - Z_a) + F_z X$$

$$M_y = -F_x (Y - Y_a) + F_y X$$

Table 10.5 Two track rails and three slide units on each track rail

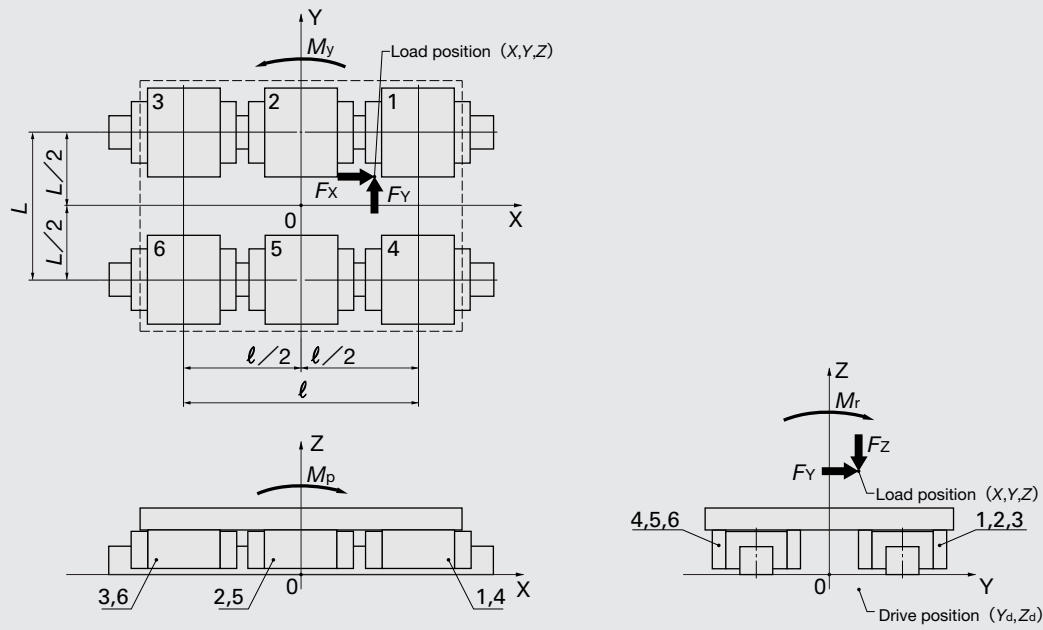

Slide unit No.	Load applied on the slide unit	
	Downward load $F_r$	Lateral load $F_a$
1	$\frac{F_z}{6} + \frac{M_r}{3L} + \frac{M_p}{2l}$	$\frac{F_y}{6} + \frac{M_y}{2l}$
2	$\frac{F_z}{6} + \frac{M_r}{3L}$	$\frac{F_y}{6}$
3	$\frac{F_z}{6} + \frac{M_r}{3L} - \frac{M_p}{2l}$	$\frac{F_y}{6} - \frac{M_y}{2l}$
4	$\frac{F_z}{6} - \frac{M_r}{3L} + \frac{M_p}{2l}$	$\frac{F_y}{6} + \frac{M_y}{2l}$
5	$\frac{F_z}{6} - \frac{M_r}{3L}$	$\frac{F_y}{6}$
6	$\frac{F_z}{6} - \frac{M_r}{3L} - \frac{M_p}{2l}$	$\frac{F_y}{6} - \frac{M_y}{2l}$

Remark : The moment loads in each direction  $M_r$ ,  $M_p$ , and  $M_y$  can be obtained by the following formulae.

$$M_r = F_y Z + F_z Y$$

$$M_p = F_x (Z - Z_d) + F_z X$$

$$M_y = -F_x (Y - Y_d) + F_y X$$

Table 10.6 Two track rails and four slide units on each track rail

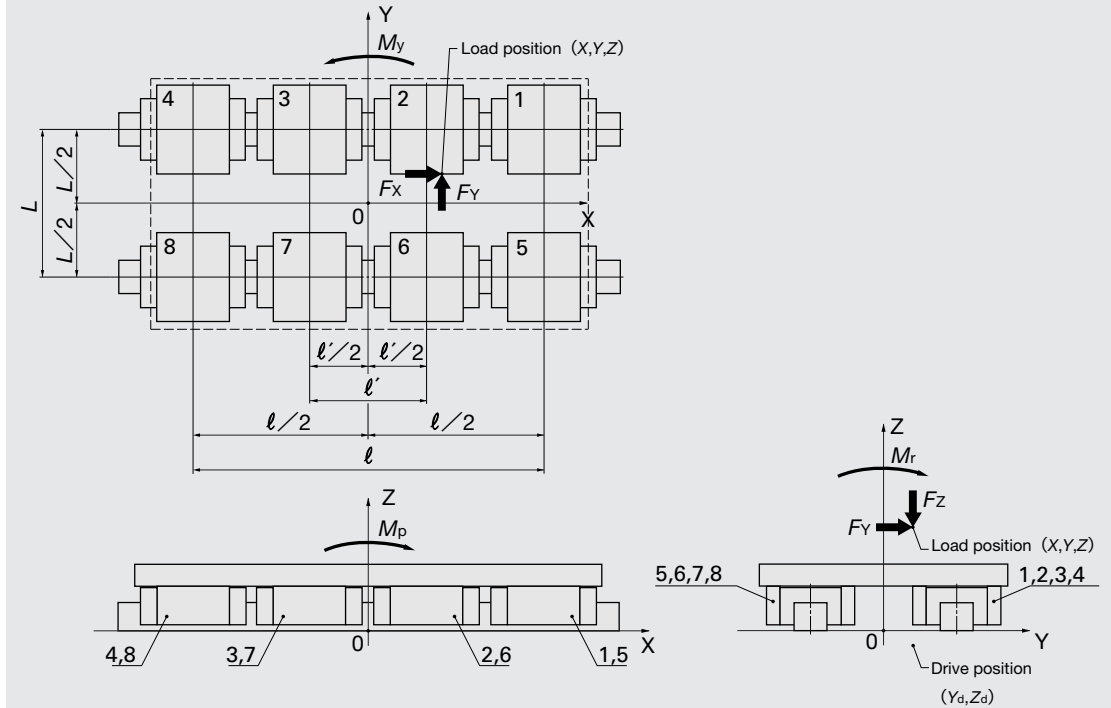

Slide unit No.	Load applied on the slide unit	
	Downward load $F_r$	Lateral load $F_a$
1	$\frac{F_z}{8} + \frac{M_r}{4L} + \frac{M_p}{2} \frac{l}{l^2 + l'^2}$	$\frac{F_y}{8} + \frac{M_y}{2} \frac{l}{l^2 + l'^2}$
2	$\frac{F_z}{8} + \frac{M_r}{4L} + \frac{M_p}{2} \frac{l'}{l^2 + l'^2}$	$\frac{F_y}{8} + \frac{M_y}{2} \frac{l'}{l^2 + l'^2}$
3	$\frac{F_z}{8} + \frac{M_r}{4L} - \frac{M_p}{2} \frac{l'}{l^2 + l'^2}$	$\frac{F_y}{8} - \frac{M_y}{2} \frac{l'}{l^2 + l'^2}$
4	$\frac{F_z}{8} + \frac{M_r}{4L} - \frac{M_p}{2} \frac{l}{l^2 + l'^2}$	$\frac{F_y}{8} - \frac{M_y}{2} \frac{l}{l^2 + l'^2}$
5	$\frac{F_z}{8} - \frac{M_r}{4L} + \frac{M_p}{2} \frac{l}{l^2 + l'^2}$	$\frac{F_y}{8} + \frac{M_y}{2} \frac{l}{l^2 + l'^2}$
6	$\frac{F_z}{8} - \frac{M_r}{4L} + \frac{M_p}{2} \frac{l'}{l^2 + l'^2}$	$\frac{F_y}{8} + \frac{M_y}{2} \frac{l'}{l^2 + l'^2}$
7	$\frac{F_z}{8} - \frac{M_r}{4L} - \frac{M_p}{2} \frac{l'}{l^2 + l'^2}$	$\frac{F_y}{8} - \frac{M_y}{2} \frac{l'}{l^2 + l'^2}$
8	$\frac{F_z}{8} - \frac{M_r}{4L} - \frac{M_p}{2} \frac{l}{l^2 + l'^2}$	$\frac{F_y}{8} - \frac{M_y}{2} \frac{l}{l^2 + l'^2}$

Remark : The moment loads in each direction  $M_r$ ,  $M_p$ , and  $M_y$  can be obtained by the following formulae.

$$M_r = F_y Z + F_z Y$$

$$M_p = F_x (Z - Z_d) + F_z X$$

$$M_y = -F_x (Y - Y_d) + F_y X$$

## ● Mean equivalent load for fluctuating load

When the load on the rolling guide fluctuates, the mean equivalent load  $P_m$  is used in place of the load  $P$  in the life calculation formula.

The mean equivalent load is a constant load which gives the basic rating life equal to that for the fluctuating load. It is obtained by the following formula.

$$P_m = \sqrt[p]{\frac{1}{L} \int_0^L P_n^p dL} \quad \dots \dots \dots (1.9)$$

where,  $P_m$  : Mean equivalent load, N  
 $L$  : Total traveling distance, m  
 $P_n$  : Fluctuating load, N  
 $p$  : Exponent (Ball guide: 3, roller guide: 10/3)

Table 11 gives calculation examples of the mean equivalent load for typical fluctuating loads.

Example	Calculation formula
<p>① Step load</p>	$P_m = \sqrt[p]{\frac{1}{L} (P_1^p L_1 + P_2^p L_2 + \dots + P_n^p L_n)}$ <p>where, <math>L_1</math> : Total traveling distance under load <math>P_1</math>, m  <math>L_2</math> : Total traveling distance under load <math>P_2</math>, m  <math>L_n</math> : Total traveling distance under load <math>P_n</math>, m</p>
<p>② Monotonously changing load</p>	$P_m \doteq \frac{1}{3} (2P_{max} + P_{min})$ <p>where, <math>P_{max}</math> : Maximum value of fluctuating load, N  <math>P_{min}</math> : Minimum value of fluctuating load, N</p>

## ● Examples of Load and Life Calculation

### Example 1

Model No. ....LWE 25 C2 R640 H	Work mass ..... $m_2 = 10$ kg
Basic dynamic load rating ..... $C = 18100$ N	Position of the center of gravity of work ..... $X_3 = 75$ mm
Basic static load rating ..... $C_0 = 21100$ N	..... $Y_3 = 80$ mm
Applied load ..... $F_{X1} = 1000$ N	..... $Z_3 = 68$ mm
..... $F_{Y1} = 2000$ N	Number of strokes per minute ... $n_1 = 5$ cpm
..... $F_{Z1} = 1000$ N	Stroke length ..... $S = 100$ mm
Load position ..... $X_1 = 60$ mm	Distance between ..... $\ell = 100$ mm
..... $Y_1 = 50$ mm	the slide units
..... $Z_1 = 83$ mm	Distance between ..... $L = 150$ mm
Table mass ..... $m_1 = 10$ kg	the track rails
Position of the center of gravity of table ..... $X_2 = 0$ mm	Drive position ..... $Y_d = 150$ mm
..... $Y_2 = 0$ mm	..... $Z_d = 10$ mm
..... $Z_2 = 43$ mm	

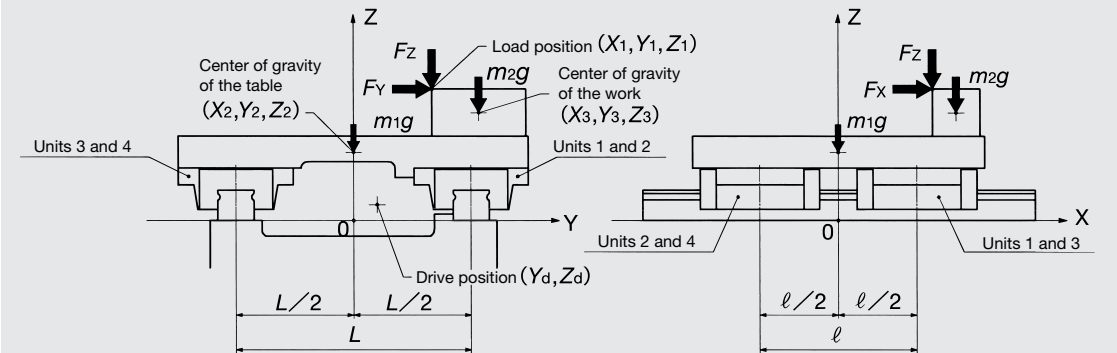

The life and static safety factor under the above conditions are calculated as follows. Load factor  $f_w$  is assumed to be 1.5.

### ① Load on the slide unit

Moments that occur due to the applied load and the table weight act around each coordinate axis of the Linear Motion Rolling Guide as shown below.

$$M_r = \sum (F_Y Z) + \sum (F_Z Y) = F_{Y1} Z_1 + F_{Z1} Y_1 + m_1 g Y_2 + m_2 g Y_3$$

$$= 2000 \times 83 + 1000 \times 50 + 10 \times 9.8 \times 0 + 10 \times 9.8 \times 80 \doteq 224000$$

$$M_p = \sum \{F_X (Z - Z_d)\} + \sum (F_Z X) = F_{X1} (Z_1 - Z_d) + F_{Z1} X_1 + m_1 g X_2 + m_2 g X_3$$

$$= 1000 \times (83 - 10) + 1000 \times 60 + 10 \times 9.8 \times 0 + 10 \times 9.8 \times 75 \doteq 140000$$

$$M_y = - \sum \{F_X (Y - Y_d)\} + \sum (F_Y X) = - F_{X1} (Y_1 - Y_d) + F_{Y1} X_1$$

$$= - 1000 \times (50 - 150) + 2000 \times 60 = 220000$$

where,  $M_r$  : Moment in the rolling direction, N · mm  
 $M_p$  : Moment in the pitching direction, N · mm  
 $M_y$  : Moment in the yawing direction, N · mm

The loads applied on each slide unit are calculated according to Table 10.4 on page 33.

$$F_{r1} = \frac{\sum F_z}{4} + \frac{M_r}{2L} + \frac{M_p}{2\ell} = \frac{F_{z1} + m_1 g + m_2 g}{4} + \frac{M_r}{2L} + \frac{M_p}{2\ell}$$

$$= \frac{1000 + 10 \times 9.8 + 10 \times 9.8}{4} + \frac{224000}{2 \times 150} + \frac{140000}{2 \times 100} \doteq 1750$$

$$F_{r2} = \frac{\sum F_z}{4} + \frac{M_r}{2L} - \frac{M_p}{2\ell} = \frac{F_{z1} + m_1 g + m_2 g}{4} + \frac{M_r}{2L} - \frac{M_p}{2\ell} \doteq 346$$

$$F_{r3} = \frac{\sum F_z}{4} - \frac{M_r}{2L} + \frac{M_p}{2\ell} = \frac{F_{z1} + m_1 g + m_2 g}{4} - \frac{M_r}{2L} + \frac{M_p}{2\ell} \doteq 252$$

$$F_{r4} = \frac{\sum F_z}{4} - \frac{M_r}{2L} - \frac{M_p}{2\ell} = \frac{F_{z1} + m_1 g + m_2 g}{4} - \frac{M_r}{2L} - \frac{M_p}{2\ell} \doteq -1150$$

$$F_{a1} = F_{a3} = \frac{\sum F_y}{4} + \frac{M_y}{2\ell} = \frac{F_{y1}}{4} + \frac{M_y}{2\ell}$$

$$= \frac{2000}{4} + \frac{220000}{2 \times 100} = 1600$$

$$F_{a2} = F_{a4} = \frac{\sum F_y}{4} - \frac{M_y}{2\ell} = \frac{F_{y1}}{4} - \frac{M_y}{2\ell} = -600$$

## ② Basic rating life

The upward/downward load and lateral load are converted into the conversion loads by formulas (1.5) and (1.6) on page 25.

$$F_{re1} = k_r |F_{r1}| = 1 \times 1750 = 1750$$

$$F_{re2} = k_r |F_{r2}| = 1 \times 346 = 346$$

$$F_{re3} = k_r |F_{r3}| = 1 \times 252 = 252$$

$$F_{re4} = k_r |F_{r4}| = 1 \times 1150 = 1150$$

$$F_{ae1} = k_a |F_{a1}| = 1 \times 1600 = 1600$$

$$F_{ae2} = k_a |F_{a2}| = 1 \times 600 = 600$$

$$F_{ae3} = k_a |F_{a3}| = 1 \times 1600 = 1600$$

$$F_{ae4} = k_a |F_{a4}| = 1 \times 600 = 600$$

where,  $k_r, k_a$  : Conversion factors for load direction (See Table 7 on page 26.)

The dynamic equivalent load is calculated by formula (1.7) on page 25.

$$P_1 = X |F_{re1}| + Y |F_{ae1}| = 1 \times 1750 + 0.6 \times 1600 = 2710$$

$$P_2 = X |F_{re2}| + Y |F_{ae2}| = 0.6 \times 346 + 1 \times 600 \doteq 808$$

$$P_3 = X |F_{re3}| + Y |F_{ae3}| = 0.6 \times 252 + 1 \times 1600 \doteq 1750$$

$$P_4 = X |F_{re4}| + Y |F_{ae4}| = 1 \times 1150 + 0.6 \times 600 = 1510$$

The basic rating life of slide unit 1 receiving the largest dynamic equivalent load is calculated. The basic rating life is obtained by the formula given in Table 2 on page 21 while considering the load factor  $f_w$ .

$$L_1 = 50 \left( \frac{C}{f_w P_1} \right)^3 = 50 \times \left( \frac{18100}{1.5 \times 2710} \right)^3 \doteq 4410$$

$$L_{h1} = \frac{10^6 L_1}{2S n_1 \times 60} = \frac{10^6 \times 4410}{2 \times 100 \times 5 \times 60} \doteq 73500$$

As the result of the above calculation, the basic rating life is about 73500 hours.

## ③ Static safety factor

The static equivalent load is calculated from the upward/downward load and lateral load by formula (1.8) on page 27.

$$P_{01} = k_{0r} |F_{r1}| + k_{0a} |F_{a1}| = 1 \times 1750 + 1 \times 1600 = 3350$$

$$P_{02} = k_{0r} |F_{r2}| + k_{0a} |F_{a2}| = 1 \times 346 + 1 \times 600 = 946$$

$$P_{03} = k_{0r} |F_{r3}| + k_{0a} |F_{a3}| = 1 \times 252 + 1 \times 1600 = 1852$$

$$P_{04} = k_{0r} |F_{r4}| + k_{0a} |F_{a4}| = 1 \times 1150 + 1 \times 600 = 1750$$

where,  $k_{0r}, k_{0a}$  : Conversion factors for load direction (See Table 8 on page 28.)

The static safety factor of slide unit 1 receiving the largest static equivalent load is obtained. The static safety factor is calculated by formula (1.3) on page 24.

$$f_{s1} = \frac{C_0}{P_{01}} = \frac{21100}{3350} \doteq 6.3$$

As the result of the above calculation, the static safety factor is about 6.3.

## Example 2

Model No. ....LWH 45 C2 R1050 B H

Basic dynamic load rating .....  $C = 74600$  N

Basic static load rating .....  $C_0 = 80200$  N

Static moment rating .....  $T_0 = 1610$  N·m  
in the  $T_0$  direction

Table mass .....  $m_1 = 100$  kg

Position of the center of gravity of table .....  $X_1 = 50$  mm  
.....  $Y_1 = 0$  mm  
.....  $Z_1 = 80$  mm

Work mass .....  $m_2 = 1000$  kg

Position of the center of gravity of work .....  $X_2 = 200$  mm  
.....  $Y_2 = 10$  mm  
.....  $Z_2 = 130$  mm

Distance between .....  $l = 200$  mm  
the slide units

Stroke length .....  $S = 500$  mm

Number of strokes per minute ...  $n_1 = 6$  cpm

Maximum travel speed .....  $V = 100$  mm/s

Time spent for acceleration ....  $t_1 = 0.1$  s

Time spent during constant ...  $t_2 = 4.9$  s  
speed motion

Time spent for deceleration ....  $t_3 = 0.1$  s

Drive position .....  $Y_d = 60$  mm

.....  $Z_d = -20$  mm

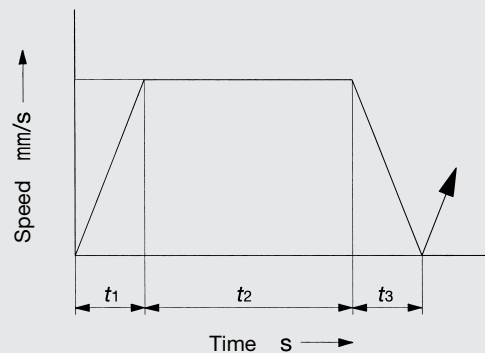
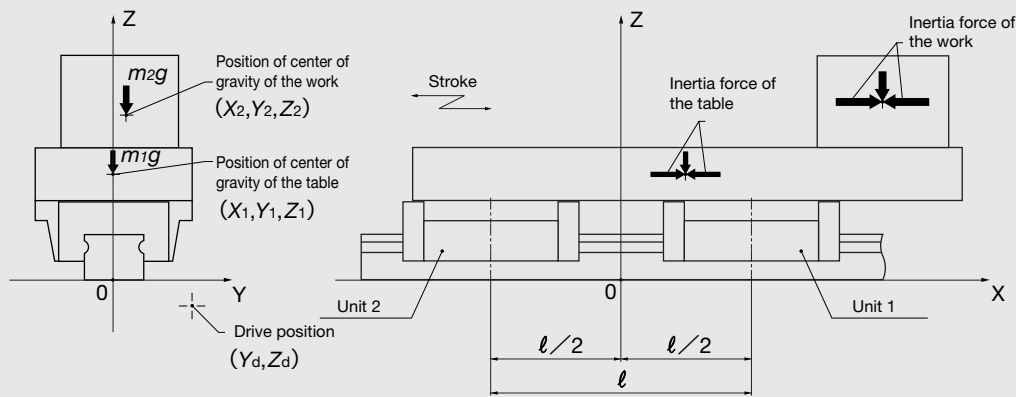

The life and static safety factor under the above conditions are calculated as follows. Load factor  $f_w$  is assumed to be 1.5.

### ① Load on the slide unit

Moments that occur due to the applied load, the table weight and the inertia force act around each coordinate axis of the Linear Motion Rolling Guide as shown below.

• During acceleration at the start of motion

$$M_r = \sum (F_Y Z) + \sum (F_Z Y) = m_1 g Y_1 + m_2 g Y_2 = 100 \times 9.8 \times 0 + 1000 \times 9.8 \times 10 \doteq 98000$$

$$M_p = \sum \{F_X (Z - Z_d)\} + \sum (F_Z X)$$

$$= m_1 \frac{V}{1000 \times t_1} (Z_1 - Z_d) + m_2 \frac{V}{1000 \times t_1} (Z_2 - Z_d) + m_1 g X_1 + m_2 g X_2$$

$$= 100 \times \frac{100}{1000 \times 0.1} \times (80 + 20) + 1000 \times \frac{100}{1000 \times 0.1} \times (130 + 20)$$

$$+ 100 \times 9.8 \times 50 + 1000 \times 9.8 \times 200 \doteq 2169000$$

$$M_y = -\sum \{F_X (Y - Y_d)\} + \sum (F_Y X)$$

$$= -m_1 \frac{V_{\max}}{1000 \times t_1} (Y_1 - Y_d) - m_2 \frac{V_{\max}}{1000 \times t_1} (Y_2 - Y_d)$$

$$= -100 \times \frac{100}{1000 \times 0.1} \times (0 - 60) - 1000 \times \frac{100}{1000 \times 0.1} \times (10 - 60) \doteq 56000$$

• During constant speed motion

$$M_r = m_1 g Y_1 + m_2 g Y_2 \doteq 98000$$

$$M_p = m_1 g X_1 + m_2 g X_2 \doteq 2010000$$

$$M_y = 0$$

• During deceleration at the end of motion

$$M_r = m_1 g Y_1 + m_2 g Y_2 \doteq 98000$$

$$M_p = -m_1 \frac{V_{\max}}{t_1} (Z_1 - Z_d) - m_2 \frac{V_{\max}}{t_1} (Z_2 - Z_d) + m_1 g X_1 + m_2 g X_2 \doteq 1850000$$

$$M_y = m_1 \frac{V_{\max}}{t_1} (Y_1 - Y_d) + m_2 \frac{V_{\max}}{t_1} (Y_2 - Y_d) \doteq -56000$$

where,  $M_r$  : Moment in the rolling direction, N·mm

$M_p$  : Moment in the pitching direction, N·mm

$M_y$  : Moment in the yawing direction, N·mm

The loads applied on each slide unit are calculated according to Table 10.2 on page 31.

• During acceleration at the start of motion

$$F_{r1} = \frac{\sum F_Z}{2} + \frac{M_p}{l} = \frac{m_1 g + m_2 g}{2} + \frac{M_p}{l} = \frac{100 \times 9.8 + 1000 \times 9.8}{2} + \frac{2169000}{200} \doteq 16200$$

$$F_{r2} = \frac{\sum F_Z}{2} - \frac{M_p}{l} = \frac{m_1 g + m_2 g}{2} - \frac{M_p}{l} \doteq -5460$$

$$F_{a1} = \frac{\sum F_Y}{2} + \frac{M_y}{l} = 280$$

$$F_{a2} = \frac{\sum F_Y}{2} - \frac{M_y}{l} = -280$$

$$M_{01} = M_{02} = \frac{M_r}{2} = 49000$$



•During constant speed motion

$$F_{r1} = \frac{100 \times 9.8 + 1000 \times 9.8}{2} + \frac{2010000}{200} \doteq 15400$$

$$F_{r2} \doteq -4660$$

$$F_{a1} = F_{a2} = 0$$

$$M_{01} = M_{02} = 49000$$

•During deceleration at the end of motion

$$F_{r1} = \frac{100 \times 9.8 + 1000 \times 9.8}{2} + \frac{1850000}{200} \doteq 14600$$

$$F_{r2} \doteq -3860$$

$$F_{a1} \doteq -280$$

$$F_{a2} \doteq 280$$

$$M_{01} = M_{02} = 49000$$

## ② Basic rating life

The upward/downward load, lateral load, and moment in the  $T_0$  direction are converted into the conversion loads by formulas (1.5) and (1.6) on page 25, and the dynamic equivalent load is calculated by formula (1.7).

•During acceleration at the start of motion

$$F_{re1} = k_r |F_{r1}| + \frac{C_0}{T_0} |M_{01}| = 1 \times 16200 + \frac{80200}{1610} \times \frac{49000}{1000} \doteq 18600$$

$$F_{re2} = 1 \times 5460 + \frac{80200}{1610} \times \frac{49000}{1000} \doteq 7900$$

$$F_{ae1} = k_a |F_{a1}| = 1.28 \times 280 \doteq 358$$

$$F_{ae2} = 1.28 \times 280 \doteq 358$$

$$P_1 = X F_{re1} + Y F_{ae1} = 1 \times 18600 + 0.6 \times 358 \doteq 18800$$

$$P_2 = X F_{re2} + Y F_{ae2} = 1 \times 7900 + 0.6 \times 358 \doteq 8110$$

•During constant speed motion

$$F_{re1} = 1 \times 15400 + \frac{80200}{1610} \times \frac{49000}{1000} \doteq 17800$$

$$F_{re2} = 1 \times 4660 + \frac{80200}{1610} \times \frac{49000}{1000} \doteq 7100$$

$$F_{ae1} = 0$$

$$F_{ae2} = 0$$

$$P_1 = 17800$$

$$P_2 = 7100$$

•During deceleration at the end of motion

$$F_{re1} = 1 \times 14600 + \frac{80200}{1610} \times \frac{49000}{1000} \doteq 17000$$

$$F_{re2} = 1 \times 3860 + \frac{80200}{1610} \times \frac{49000}{1000} \doteq 6300$$

$$F_{ae1} = 1.28 \times 280 \doteq 358$$

$$F_{ae2} = 1.28 \times 280 \doteq 358$$

$$P_1 = 1 \times 17000 + 0.6 \times 358 \doteq 17200$$

$$P_2 = 1 \times 6300 + 0.6 \times 358 \doteq 6510$$

Because the dynamic equivalent load changes stepwise along the traveling distance, the average load is calculated from ① in Table 11 on page 36.

$$P_{m1} = \sqrt[3]{\frac{1}{S} \left( P_1^3 \frac{V_{\max} t_1}{2} + P_2^3 V_{\max} t_2 + P_3^3 \frac{V_{\max} t_3}{2} \right)}$$

$$= \left\{ \frac{1}{500} \times \left( 18800^3 \times \frac{100 \times 0.1}{2} + 17800^3 \times 100 \times 4.9 + 17200^3 \times \frac{100 \times 0.1}{2} \right) \right\}^{1/3} \doteq 17800$$

$$P_{m2} = \left\{ \frac{1}{500} \times \left( 8110^3 \times \frac{100 \times 0.1}{2} + 7100^3 \times 100 \times 4.9 + 6510^3 \times \frac{100 \times 0.1}{2} \right) \right\}^{1/3} \doteq 7110$$

The basic rating life of slide unit 1 receiving the largest dynamic equivalent load is calculated. The basic rating life is obtained by the formula given in Table 2 on page 21 while considering the load factor  $f_w$ .

$$L_1 = 50 \left( \frac{C}{f_w P_{m1}} \right)^3 = 50 \left( \frac{74600}{1.5 \times 17800} \right)^3 \doteq 1090$$

$$L_{h1} = \frac{10^6 L_1}{2S n_1 \times 60} = \frac{10^6 \times 1090}{2 \times 500 \times 6 \times 60} \doteq 3030$$

As the result of the above calculation, the basic rating life is about 3030 hours.

## ③ Static safety factor

The static equivalent load is calculated from the upward/downward load and lateral load by formula (1.8) on page 27.

•During acceleration at the start of motion

$$P_{01} = k_{0r} |F_{r1}| + k_{0a} |F_{a1}| + \frac{C_0}{T_0} |M_{01}| = 1 \times 16200 + 1.28 \times 280 + \frac{80200}{1610} \times \frac{49000}{1000} \doteq 19000$$

$$P_{02} = k_{0r} |F_{r2}| + k_{0a} |F_{a2}| + \frac{C_0}{T_0} |M_{02}| = 1.19 \times 5460 + 1.28 \times 280 + \frac{80200}{1610} \times \frac{49000}{1000} \doteq 9300$$

•During constant speed motion

$$P_{01} = 1 \times 15400 + 1.28 \times 0 + \frac{80200}{1610} \times \frac{49000}{1000} \doteq 19000$$

$$P_{02} = 1.19 \times 4660 + 1.28 \times 0 + \frac{80200}{1610} \times \frac{49000}{1000} \doteq 7990$$

•During deceleration at the end of motion

$$P_{01} = 1 \times 14600 + 1.28 \times 280 + \frac{80200}{1610} \times \frac{49000}{1000} \doteq 17400$$

$$P_{02} = 1.19 \times 3860 + 1.28 \times 280 + \frac{80200}{1610} \times \frac{49000}{1000} \doteq 7390$$

The static safety factor of slide unit 1 during acceleration at the start receiving the largest static equivalent load is calculated. The static safety factor is obtained by formula (1.3) on page 24.

$$f_s = \frac{C_0}{P_{01}} = \frac{80200}{19000} \doteq 4.2$$

As the result of the above calculation, the static safety factor is about 4.2.

## Preload

### ● Purpose of preload

A clearance may be given to linear motion rolling guides, when the load is small and very smooth motion is required. However, in many cases, preload is preferred, because it eliminates play in the guide mechanism and increases the rigidity of rolling guide.

Preload is given by applying an internal stress, in advance, to the contact area between raceways and rolling elements. When a load is applied on the preloaded rolling guide, elastic deformation due to the load is smaller compared to that without preload by the effect of this internal stress, and the rigidity of rolling guide is increased. (See Fig. 4.)

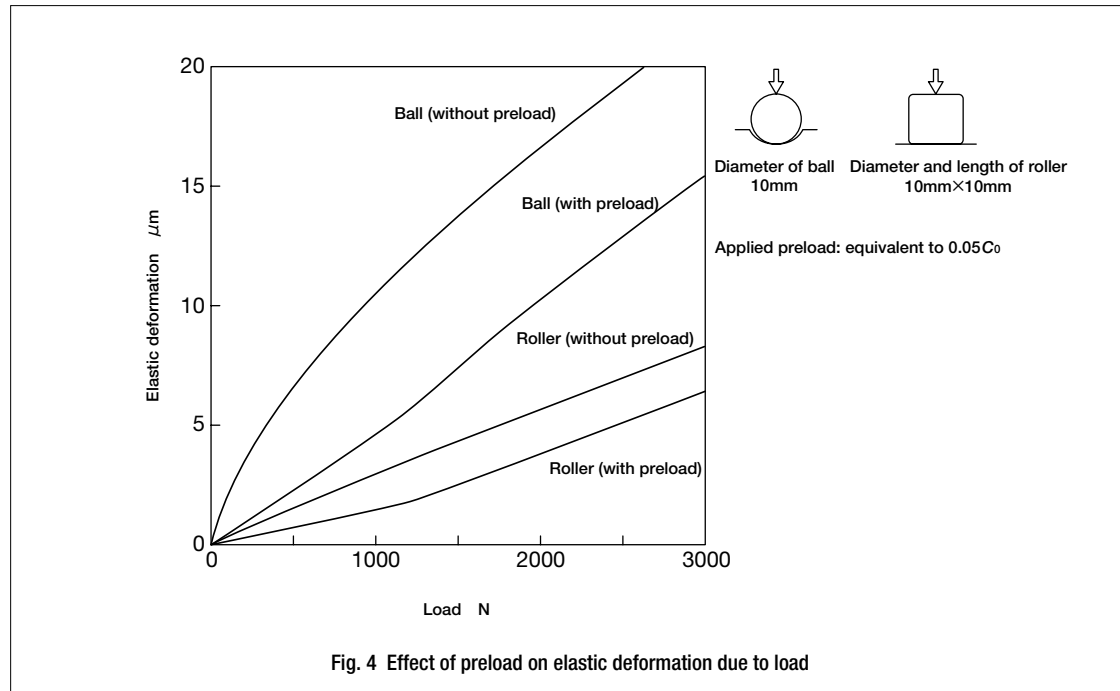

### ● Setting preload

The preload amount is determined by considering the characteristics of the machines and equipment on which the rolling guide is mounted and the nature of load acting on the rolling guide. The standard amount of preload for linear motion rolling guides is, in general, approx. 1/3 of load when the rolling elements are balls (steel balls) and approx. 1/2 of load when they are rollers (cylindrical rollers). If the rolling guides are required to have very high rigidity to withstand vibration or fluctuating load, a larger preload may be applied.

### Cautions on Preload Selection

Even when high rigidity must be obtained, excessive preload should be avoided, because it will produce an excessive stress between rolling elements and raceways, and eventually result in short life of rolling guides. It is important to apply a proper amount of preload, considering the operating conditions. When linear motion rolling guides must be used with a large preload, consult **IKO** for further information. Linear Bushing and Stroke Rotary Bushing should never be given a large amount of preload.

## Friction

### ● Friction of Linear Motion Rolling Guides

The static friction (start-up friction) of linear motion rolling guides is much lower than that of conventional plain guides. Also, the difference between static friction and dynamic friction is small, and friction varies little when velocity changes. These are excellent features of linear motion rolling guides, and account for their ability to reduce power consumption, suppress operating temperature rise, and increase traveling speed.

Since frictional resistance and variation are small, high speed response to motion commands and high accuracy positioning can be achieved.

### ● Friction coefficient

The frictional resistance of rolling guides varies with their type, load, traveling speed and lubricant used. Generally speaking, lubricants or seals are major factors in determining the frictional resistance in light load and high speed applications, while the magnitude of load is the major factor in heavy load and low speed applications. The frictional resistance of rolling guides actually depends on various factors, but the following formula is used for practical purposes.

$$F = \mu P \dots\dots\dots (1.10)$$

where,  $F$  : Frictional resistance, N

$\mu$  : Dynamic friction coefficient

$P$  : Load, N

For sealed guides, seal resistance is added to the above value, but this resistance varies greatly with the interference amount of seal lip and lubrication conditions.

Where the methods of lubrication and mounting are correct and the load is moderate, the friction coefficients of linear motion rolling guide in operation are within the range shown in Table 12. Generally, friction coefficient is large under small load. Fig. 5 gives typical examples of this relationship.

Table 12 Friction coefficient

Series	Dynamic friction coefficient $\mu$ ( <sup>1</sup> )
Linear Way	0.0040~0.0060
Linear Roller Way	0.0020~0.0040
Linear Ball Spline	0.0020~0.0040
Crossed Roller Way	0.0010~0.0030
Precision Linear Slide	0.0010~0.0020
Linear Bushing	0.0020~0.0030
Stroke Rotary Bushing	0.0006~0.0012
Flat Roller Cage	0.0010~0.0030

Note(1) : These friction coefficients do not include the seal friction.

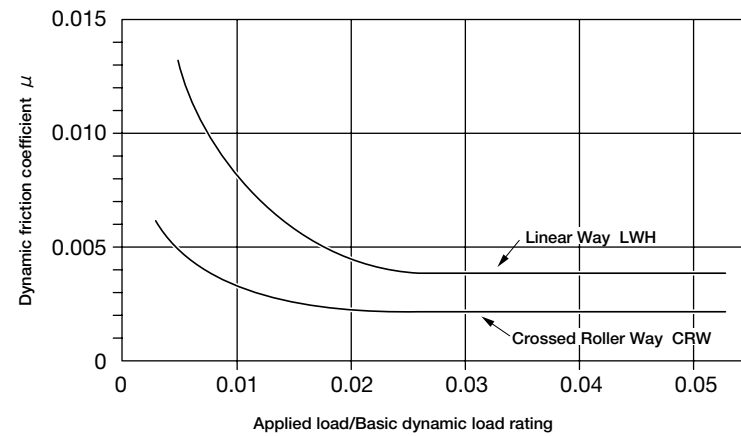

Fig. 5 Relationship between load and friction coefficient

## Purpose of lubrication

The purpose of lubrication for linear motion rolling guides is to keep raceways, rolling elements, etc. from direct metal-to-metal contact, and thereby reduce friction and wear and prevent heat generation and seizure. When an adequate oil film is formed between the raceways and rolling elements at the rolling contact area, the contact stress due to load can be moderated. Lubrication is important for ensuring the reliability of linear motion rolling guides.

## Selection of lubricant

To obtain the full performance of linear motion rolling guides, it is necessary to select an appropriate lubricant and lubrication method by considering the type, load and speed of each linear motion rolling guide. However, as compared with plain guides, lubrication of linear motion rolling guides is much simpler. Only a small amount of lubricant is needed and the replenishment interval is longer, so maintenance can be greatly reduced. Oil and grease are the two most commonly used lubricants for linear motion rolling guides.

## Grease lubrication

For grease lubrication of linear motion rolling guides, lithium-soap base grease (Consistency No.2 of JIS) is commonly used. For rolling guides operating under heavy load conditions, grease containing extreme pressure additives is recommended.

In clean and high-vacuum environments, where low dust generation performance and low vaporization characteristics are required, greases containing a synthetic base oil or a soap other than the lithium-soap base are used. For applications in these environments, due consideration is necessary to select a grease type that is suitable for the special operating conditions and achieves satisfactory lubrication performance at the same time.

## Grease Replenishment Interval

The quality of any grease will gradually deteriorate as operating time passes. Therefore, periodic relubrication is necessary. The relubrication interval varies depending on the operating conditions of the rolling guides. A six month interval is generally recommended and, if the machine operation consists of reciprocating motions with many cycles and long strokes, relubrication every three months is recommended.

## Grease Replenishment Method

New grease must be supplied through a grease feed device such as a grease nipple until old grease is discharged. After grease is replenished, running in is performed and excess grease will be discharged from the inside of rolling guide. Discharged grease must then be removed before starting the operation.

The amount of grease required for standard replenishment is about 1/3 to 1/2 of the free space inside the linear motion rolling guide. When grease is supplied from a grease nipple for the first time, there will be grease lost in the replenishment path. The amount lost should be taken into consideration.

Generally, immediately after grease is replenished, frictional resistance tends to increase. If running-in is performed for 10 to 20 reciprocating cycles after excess grease is discharged, frictional resistance becomes small and stable.

For applications where low frictional resistance is required, the replenishment amount of grease may be reduced, but it must be kept to an appropriate level so as not to give a bad influence on the lubrication performance.

## Mixing of Different Grease Types

Mixing different types of greases may result in changing the properties of base oil, soap base, or additives used, and, in some cases, severely deteriorate the lubrication performance or cause a trouble due to chemical changes of additives. Old grease should therefore be removed thoroughly before filling with new grease.

## Grease Brands for Linear Motion Rolling Guides

Name	Base oil	Thickener	Service range °C	Remarks	
ALVANIA GREASE EP2	SHELL	Mineral oil	Lithium	-20~+110	General applications, contains extreme pressure additives
ALVANIA GREASE S2	SHELL	Mineral oil	Lithium	-25~+120	General applications
MULTEMP PS NO.2	KYODO OIL	Synthetic oil, mineral oil	Lithium	-50~+130	General applications
<b>IKO</b> CLEAN ENVIRONMENT GREASE CG2	NIPPON THOMPSON	Synthetic oil	Urea	-40~+200	For clean environment, long life
<b>IKO</b> CLEAN ENVIRONMENT GREASE CGL	NIPPON THOMPSON	Synthetic oil, mineral oil	Lithium/Calcium	-30~+120	For clean environment, Low friction
DEMNUM GREASE L-200 (1)	DAIKIN	Synthetic oil	Ethylene tetra-fluoride	-60~+300	For clean environment
FOMBLIN YVAC3 (1)	AUSIMONT	Synthetic oil	Ethylene tetra-fluoride	-20~+200	For vacuum environment
<b>IKO</b> ANTI-FRETTING CORROSION GREASE	NIPPON THOMPSON	Synthetic oil	Urea	-50~+170	Fretting-proof
6459 GREASE N	SHELL	Mineral oil	Poly-urea	—	Fretting-proof

Note(1) : Set a little shorter replenishment interval.

Remark : When using a grease type, check the selected type according to the manufacturer's catalog of grease. For applications other than those described above, consult **IKO** for further information.

## Oil lubrication

For oil lubrication, heavy loads require a higher oil viscosity and higher operating speeds require a lower viscosity. Generally, for linear motion rolling guides operating under heavy loads, lubrication oil with a viscosity of about 68 mm<sup>2</sup>/s is used. For linear motion rolling guides under light loads at high speeds, lubrication oil with a viscosity of about 13 mm<sup>2</sup>/s is used.

## Operating Environment

### Operating temperature

When linear motion rolling guides are operated at a temperature exceeding 150°C, the basic dynamic load rating must be corrected by using the temperature factor.

Some linear motion rolling guides comprise synthetic resin components. When they are used at high temperature, these components may not endure the high temperature. The maximum operating temperature for these linear motion rolling guides is 120°C. For continuous operation, they can be operated at temperatures not exceeding 100°C. C-Lube Linear Way must be used under 80°C (maximum). If the operating temperature exceeds 100°C, consult **IKO** for further information.

### Dust protection

#### Purpose of dust protection

To obtain the full performance of linear motion rolling guides, it is important to protect them from the intrusion of dust and other harmful foreign matter. Select an effective sealing or dust-protection device to withstand any operating conditions that might be imposed.

### Method of dust protection

Sealed types are available in some linear motion rolling guide series.

Linear Way and Linear Roller Way have end seals as a standard specification. In addition, double seals or scrapers are provided as special specifications for improvement in dust protection performance. Caps for covering the track rail mounting holes and a rail cover plate (Fig. 6) for covering the top surface of the track rail will further increase the reliability for dust protection.

However, when a large amount of dust or foreign particles are floating in air, or when large foreign substances such as chips or sand fall onto raceways, dust protection becomes difficult. In this case, it is recommended to cover the entire guide mechanism with bellows (Fig. 7), telescopic shields, etc.

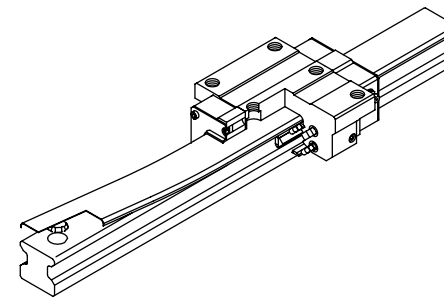

Fig. 6 Rail cover plate

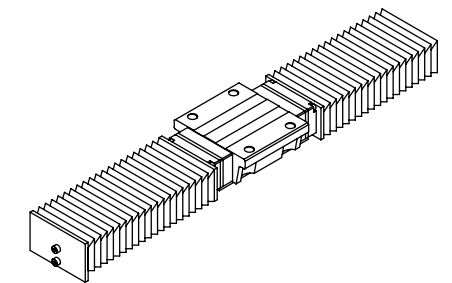

Fig. 7 Bellows

# Linear Way Linear Roller Way



Description of Linear Way and Linear Roller Way	52
C-Lube Linear Way ML	A-2
C-Lube Linear Way ME	A-18
C-Lube Linear Way MH	A-40
C-Lube Linear Way MUL	A-60
C-Lube Linear Roller Way Super MX	A-70
C-Lube Linear Ball Spline MAG	A-100
Linear Way L	B-2
Linear Way E	B-30
Low Decibel Linear Way E	B-56
Linear Way H	B-74
Linear Way F	B-110
Linear Way U	B-130
Linear Way Module	B-142
Linear Roller Way Super X	C-2

LINEAR WAY  
LINEAR ROLLER WAY

## Features of Linear Way and Linear Roller Way

**IKO** Linear Way and Linear Roller Way are linear motion rolling guides which achieve endless linear motion of a slide unit along a track rail by re-circulating rolling elements inside the slide unit. Slide units and track rails are fixed on machines and equipment with mounting bolts, and a highly accurate linear motion can readily be obtained. As compared with other types of linear motion rolling guides, Linear Way and Linear Roller Way have the following features.

### 1 Lower manufacturing cost

It is not necessary to prepare a guide plane on machines and equipment by heat treatment and surface finishing. A large reduction in man-hour and cost can be achieved in the design and manufacturing of linear motion guide mechanism.

### 2 Large load capacity in any directions

Loads in any directions can be received without making a complicated guide structure. A linear motion rolling guide mechanism can readily be obtained that can withstand moment load and complex load.

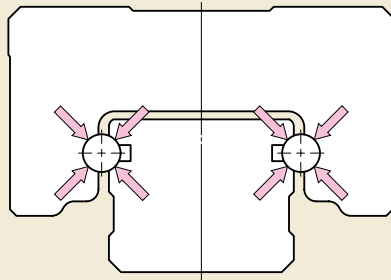

### 3 Wide range of selections for high degree of design freedom

A wide range of variations in types and sizes makes it possible to select a model most suitable for the operating conditions. Size variations range from track rail width 1 mm to 100 mm.

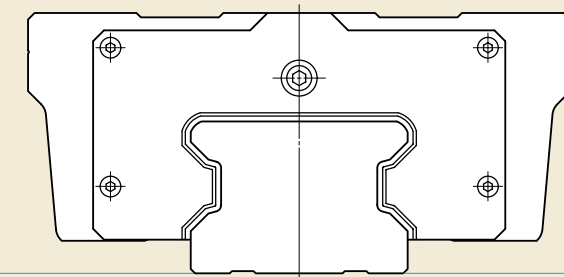

LWL1

C	66.8 N
C <sub>0</sub>	113 N

LRXG100

C	498 000 N
C <sub>0</sub>	821 000 N

### 4 High rigidity for achieving compact design of machines and equipment

Because the track rail is firmly fixed on the mating mounting surface over its total length, high rigidity can be obtained in comparison with shaft type guides which may be affected by shaft bending.

## Features of Linear Way

**IKO** Linear Way features the design in which large diameter steel balls are arranged in two rows with each ball making four-point contact with the raceways, and has following advantages over other types.

### 1 Large load capacity in any directions

The simple two-row raceway design makes it possible to incorporate large diameter steel balls for high load ratings. Loads in any directions can almost uniformly be received.

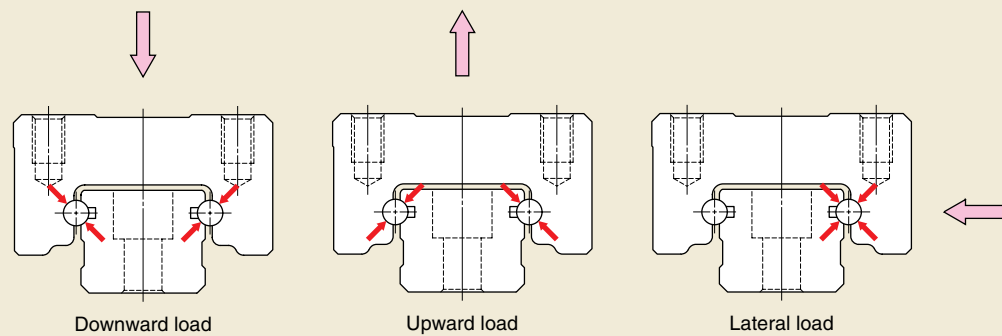

Load acting on rolling elements in each loading direction

### 2 Excellent strength against moment load and complex load

A large moment load capacity can be obtained, since the moment arm distance  $l$  is long as shown in the figure. Load capacity under complex load is also large.

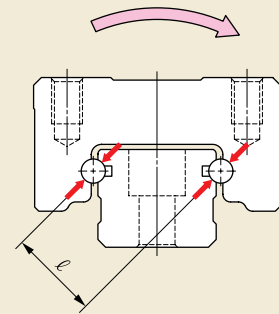

When  $T_0$  moment is applied

### Four-points contact structure

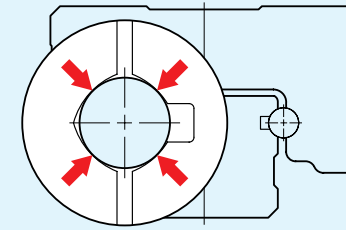

### 3 High accuracy with simple structure

The simple two-row raceway design minimizes the number of potential errors in manufacturing and measurement, and high dimensional accuracy of raceways can be obtained. Interchangeable specification products can be manufactured benefiting from this feature by rigorous control of the dimensional accuracy of individual slide units and track rails.

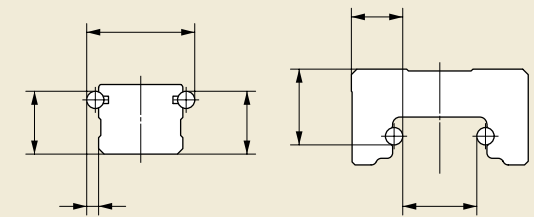

Track rail      Slide unit

Measurement of raceway accuracy

### 4 Smooth operation and low noise

Smooth and quiet operation is achieved, because all raceway contours are precisely ground and the ball re-circulating routes are designed based on the analysis of optimal functional characteristics.

### 5 Accurate and simple installation

Accurate parallel mounting of two track rails can be made by aligning the attendant rail to the datum rail. Because the rigidity in the lateral direction is high, frictional resistance of poorly aligned two rails will steeply increase giving a warning so that misalignment can be easily detected and corrected. Potential troubles due to misalignment during actual operation such as short life, degradation in guide accuracy can therefore be eliminated in advance. It is easy to butt-joint track rails to form longer lengths.

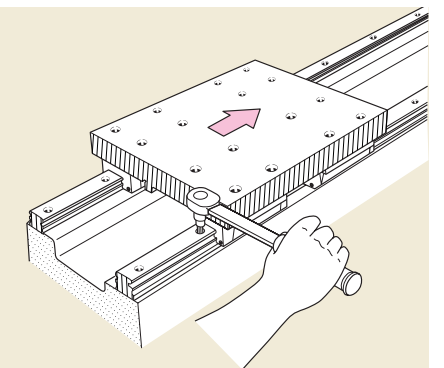

## Features of Linear Roller Way

**IKO** Linear Roller Way features the design in which four rows of cylindrical rollers are arranged in a highly rigid casing in a well balanced form. The rollers in each row are arranged in parallel to each other and not crossed alternately. These linear motion rolling guides achieve smooth motion with high rigidity, high accuracy and high reliability.

### 1 Super high rigidity

Very high rigidity is achieved owing to the excellent elastic deformation characteristics of cylindrical rollers which give smaller elastic deformation under load as compared with steel balls, and, in addition, to a large number of cylindrical rollers incorporated in the slide unit.

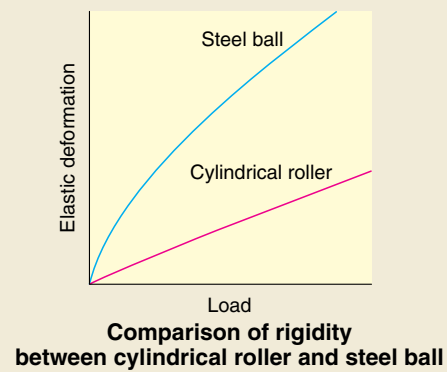

### 2 Super high load capacity

Cylindrical rollers give a larger contact area compared to steel balls, so higher load capacity is attainable when cylindrical rollers are used. Incorporating a large number of cylindrical rollers, Linear Roller Way has a very high load rating.

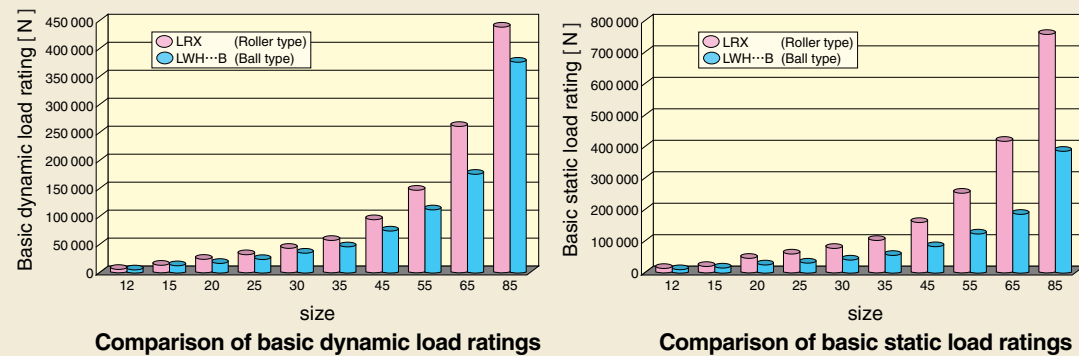

Remark : The calculation formulas of rating life are different for roller type and ball type. Generally, if the values of basic dynamic load rating are the same, the life of the roller type is longer.

### Parallel arrangement

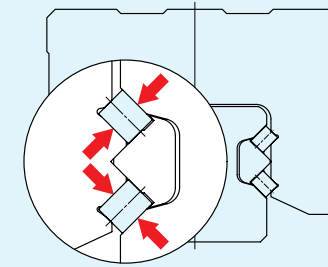

### 3 Excellent load balance and moment load capacity

Cylindrical rollers are arranged in a well-balanced form so that they can uniformly withstand loads in all directions. In addition, rows are arranged in such a way that the moment arm distance  $\ell$  between the loading points is large under  $T_0$  moment. A high moment load capacity can be obtained.

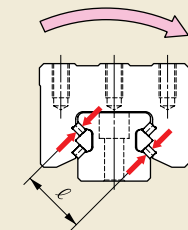

When  $T_0$  moment is applied

### 4 Excellent vibration characteristics

As compared with ball types of the same size, these guides have higher rigidity and give smaller deformation under repeated fluctuating load. The natural frequency is high, and the vibration damping time is short.

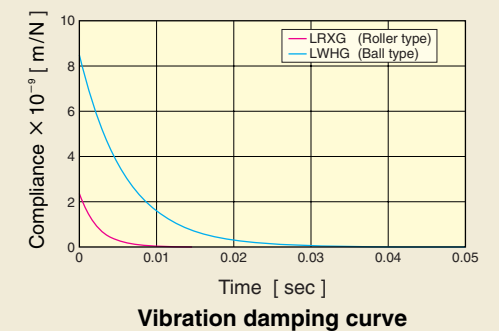
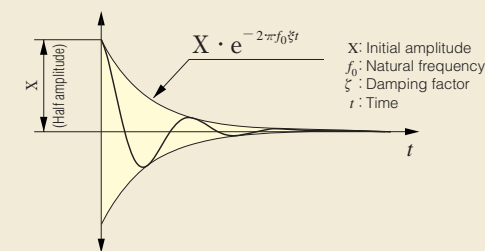

### 5 High running performance

The optimum design based on the analysis of roller re-circulation behavior achieves smooth and quiet motion.

Remark : Features mentioned above are those of C-Sleeve Linear Roller Way Super MX and Linear Roller Way Super X which are the typical roller guides.

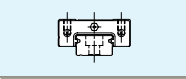
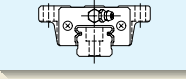
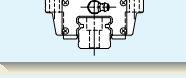
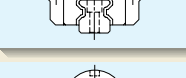
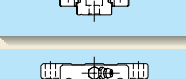
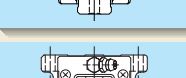
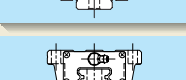
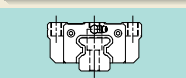
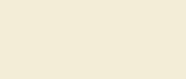

Linear Motion Rolling Guides		Series		Reference page		
		Series	Reference page			
Linear Motion Rolling Guides	Maintenance Free Series	C-Lube Linear Way C-Lube Linear Roller Way C-Lube Linear Ball Spline	Miniature Maintenance Free Linear Way <b>C-Lube Linear Way ML</b>		C-Lube Linear Way ML is a linear motion rolling guide, incorporating the C-Lube as a components part for lubrication in the slide unit of miniature type Linear Way L series to achieve maintenance free operations for a long period of time.	A-2 ~
			Compact Maintenance Free Linear Way <b>C-Lube Linear Way ME</b>		C-Lube Linear Way ME is a linear motion rolling guide, incorporating the C-Lube as a components part for lubrication in the slide unit of compact type Linear Way LWE series to achieve maintenance free operations for a long period of time.	A-18 ~
			High Rigidity Maintenance Free Linear Way <b>C-Lube Linear Way MH</b>		C-Lube Linear Way MH is a linear motion rolling guide, incorporating the C-Lube as a components part for lubrication in the slide unit of high rigidity type Linear Way LWH series to achieve maintenance free operations for a long period of time.	A-40 ~
			U-shaped Maintenance Free Linear Way <b>C-Lube Linear Way MUL</b>		C-Lube Linear Way MUL is a linear motion rolling guide, incorporating the C-Lube as a components part for lubrication in the slide unit of U shaped track rail type Linear Way LWUL series to achieve maintenance free operations for a long period of time.	A-62 ~
			Maintenance Free Linear Roller Way <b>C-Lube Linear Roller Way Super MX</b>		C-Lube Linear Roller Way Super MX is a high performance roller type linear motion rolling guide,featuring high reliability,high rigidity,high accuracy and smooth motion which is required from machine tool, semiconductor manufacturing and liquid crystal manufacturing equipments.	A-70 ~
			Maintenance Free Linear ball Spline <b>C-Lube Linear Ball Spline MAG</b>		A maintenance free type has been released for <b>IKO</b> Ball Spline MAG having an overwhelmingly high market share in the field of semiconductor and liquid crystal manufacturing systems that are forced to be operated in severe operating conditions of high acceleration/deceleration motion.	A-100 ~
			Linear Way	Linear Way	Miniature Type Linear Way <b>Linear Way L</b>	
	Compact Type Linear Way <b>Linear Way E</b>				Lower, narrower and shorter. Compactness has been pursued in every dimension.	B-30 ~
	Low Decibel Linear Way <b>Low Decibel Linear Way E</b>				Plastic separators are incorporated to eliminate direct contact between balls and thus achieve smooth and quiet motion.	B-56 ~
	High Rigidity Type Linear Way <b>Linear Way H</b>				Incorporating large diameter steel balls as rolling elements, the product of this series has large load ratings.	B-74 ~
	Wide Rail Type Linear Way <b>Linear Way F</b>				As a wide track rail is used, a large moment load as well as a complex load can be received. This series is best suited to a single row rail arrangement, which provides a simple guide structure.	B-110 ~
	U-shaped Track Rail Linear Way <b>Linear Way U</b>				By adopting a U-shaped track rail, rigidity against moment and torsion is greatly improved.	B-130 ~
	Linear Way Module	Linear Way Module LM Linear Way Module M				The product of this series requires the smallest mounting space. A track rail and a slide member are designed as a set, and two sets are arranged in parallel for standard applications.
	Linear Roller Way	Linear Roller Way Super X		Cylindrical rollers are used as rolling elements, and arranged in four rows with the rollers in each row being aligned in parallel to each other. Excellent load carrying performance is obtained in all directions. The mounting dimensions of this series are interchangeable with those of Linear Way H, so these two series can be exchanged readily.	C-2 ~	

## Maintenance Free Linear Motion Rolling Guide Series

This Maintenance Free series can reduce the man-hours for troublesome lubrication control and achieve long-term maintenance free operations. In Maintenance Free series, Miniature type C-Lube Linear Way ML, Compact type C-Lube Linear Way ME, High Rigidity type C-Lube Linear Way MH, U-shaped track rail type C-Lube Linear Way MUL, C-Lube Linear Roller Way Super MX, C-Lube Linear Ball Spline MAG and Linear (Roller) Ways with self lubrication Capillary plate are available.

**Wide variation of C-Lube Linear Way**

**Miniature type**

**C-Lube Linear Way ML**  
**ML · MLF**

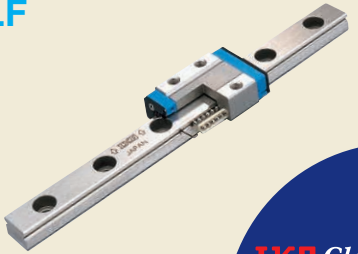

**U.S. PATENTED**  
No. 6,729,761  
6,712,511  
5,435,649  
5,289,779  
5,250,126  
4,652,147  
4,505,522

**Compact type**

**C-Lube Linear Way ME**  
**ME**

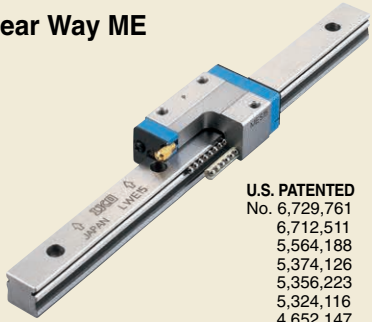

**U.S. PATENTED**  
No. 6,729,761  
6,712,511  
5,564,188  
5,374,126  
5,356,223  
5,324,116  
4,652,147  
4,505,522

**High Rigidity type**

**C-Lube Linear Way MH**  
**MH**

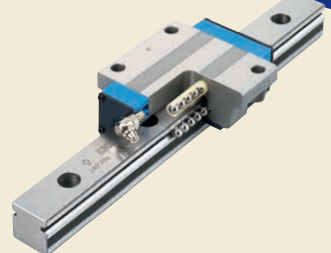

**U.S. PATENTED**  
No. 6,729,761  
6,712,511  
5,622,433  
5,564,188  
5,374,126  
4,652,147  
4,610,488  
4,505,522

**U-shaped track rail type**

**C-Lube Linear Way MUL**  
**MUL**



**U.S. PATENTED**  
No. 6,729,761  
6,712,511  
6,309,107  
5,435,649  
5,289,779  
5,250,126  
4,652,147  
4,505,522

**Roller type**

**C-Lube Linear Roller Way Super MX**  
**MX**

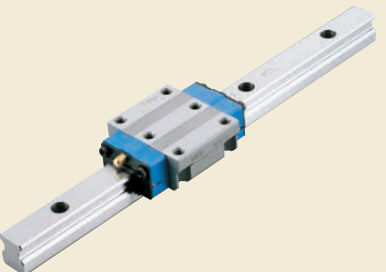

**U.S. PATENTED**  
No. 5,800,064  
5,193,914  
5,564,188  
5,374,126  
5,622,433  
6,176,617  
5,967,667  
5,464,288

**Ball Spline type**

**C-Lube Linear Ball Spline MAG**  
**MAG**

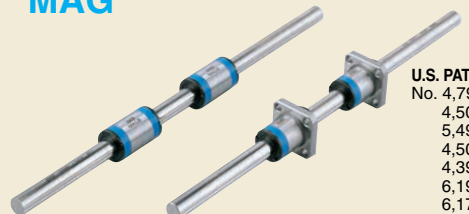

**U.S. PATENTED**  
No. 4,799,803  
4,505,522  
5,490,729  
4,505,522  
4,390,215  
6,190,046  
6,176,617  
6,082,899  
5,967,667  
5,464,288  
5,356,223



**IKO Clean Lubrication**  
**C-Lube**  
Friendly to Maintenance  
Gentle to the Earth

## Feature of C-Lube Linear Way

**Maintenance free for 20,000km or 5 years**  
**Interchangeable is newly available.**

### Maintenance Free

Ability of lubrication is maintained for long term, the cost of lubrication management and system can be reduced.

### Ecology

C-Lube contributes to global environment protection because the amount of lubricant can be minimized.

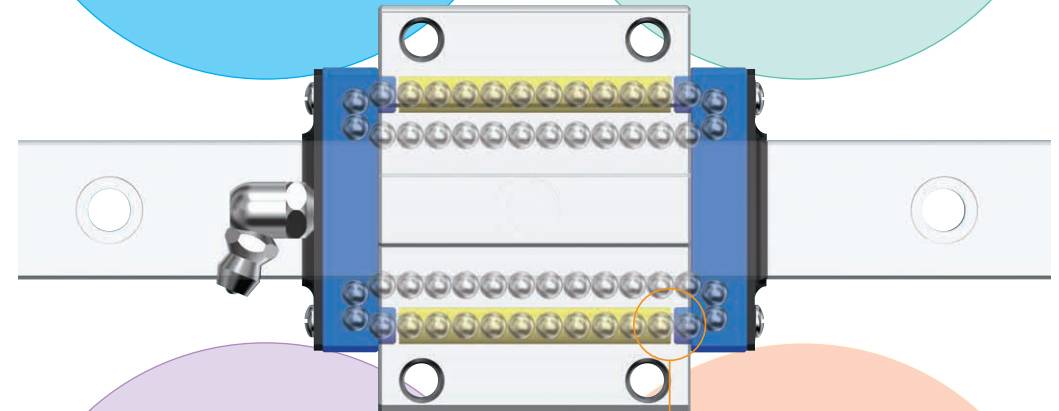

### Compactness

No increase in carriage length unlike a bolt-on external lubrication parts. No loss of available stroke length when replacing standard unit.

### Smoothness

Light and smooth running is achieved by the improvement of design. It is designed not to have contact to track rail and this has brought a very smooth friction.

## Structure of C-Lube Linear Way

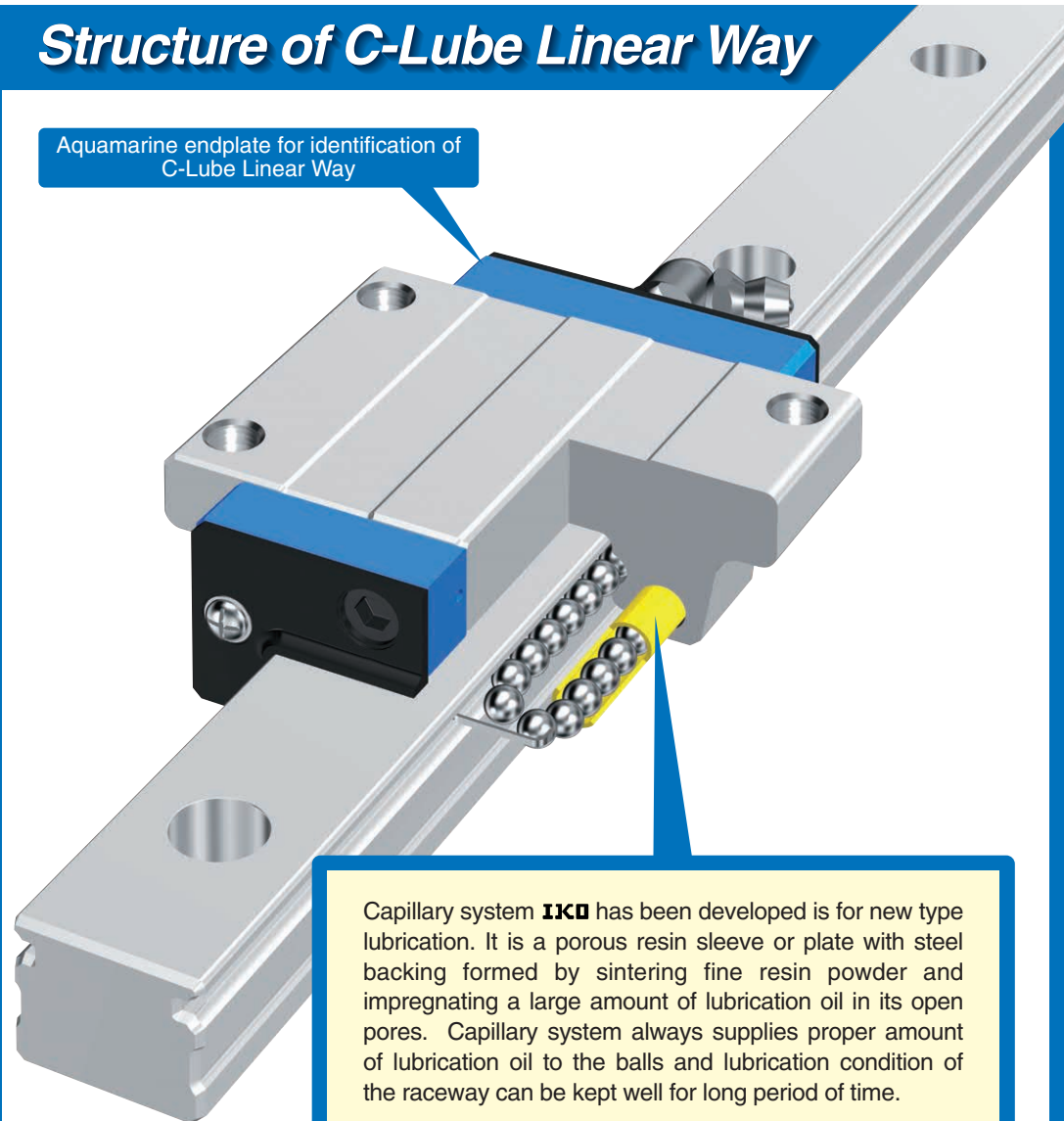

Capillary system **IKO** has been developed is for new type lubrication. It is a porous resin sleeve or plate with steel backing formed by sintering fine resin powder and impregnating a large amount of lubrication oil in its open pores. Capillary system always supplies proper amount of lubrication oil to the balls and lubrication condition of the raceway can be kept well for long period of time.

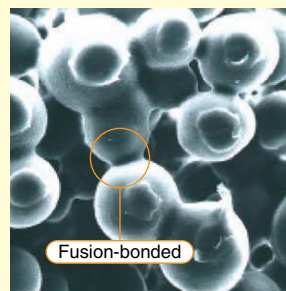

**Before impregnating oil**  
Resin particles are strongly fusion-bonded.

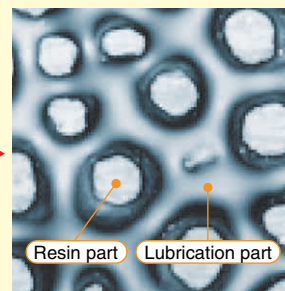

**After impregnating oil**  
(Capillary lubrication structure)  
Lubricant is retained in cavities amongst resin particles.

## C-Lube lubrication mechanism

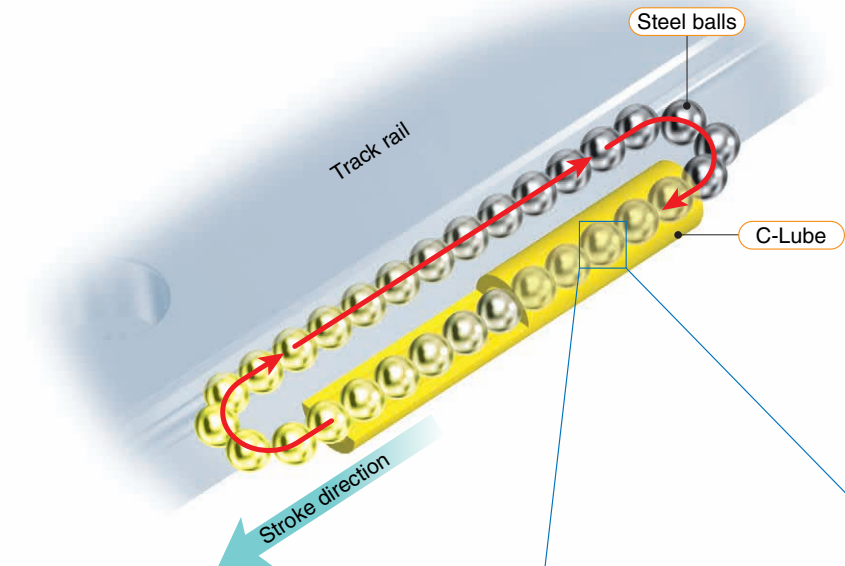

### Lubricant is distributed by the circulation of the steel balls.

Lubricant is supplied directly to the steel balls. As the steel circulate, the lubricant is distributed to the loading area along the track rail. This results in adequate lubrication being properly maintained in the loading area for a long time.

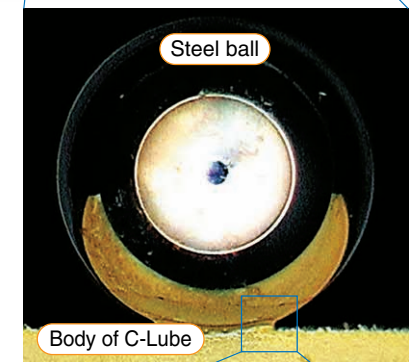

### Lubricant is deposited directly to the surface of the steel balls.

The surface of C-Lube is always covered with the lubricant. Lubricant is continuously supplied to the surface of steel ball by surface tension in the contact of C-Lube surface and steel balls. New oil permeates automatically from the core of C-Lube to the internal surface that comes in contact with steel balls.

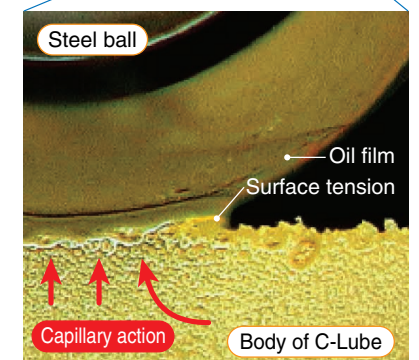

## Interchangeable Specification

**IKO** Linear Way and Linear Roller Way include interchangeable specification products. The track rails and the slide units of this specification can be handled separately and can be assembled to make a set as required.

The interchangeable specification guides are produced with the original precision manufacturing technology, making the most of the **IKO** guide designs: namely, the simple two-row raceway and four-point contact ball design of ball types, and the unique four-row raceway and parallel recirculating roller design of roller types. The dimensional accuracy of both slide units and track rails is strictly controlled to achieve the interchangeability of higher standard.



### Wide range of variations

The models for which the interchangeable specification is applicable are indicated by a star-mark (☆) in the table of dimensions of each series.

<b>C-Lube Linear Way ML</b> (page A-2 to page A-17) 6 types and 37 models	
<b>C-Lube Linear Way ME</b> (page A-18 to page A-39) 18 types and 81 models	<b>C-Lube Linear Way MH</b> (page A-40 to page A-61) 12 types and 52 models
<b>C-Lube Linear Roller Way Super MX</b> (page A-70 to page A-99) 13 types and 75 models	<b>C-Lube Linear Ball Spline MAG</b> (page A-100 to page A-109) 4 types and 20 models
<b>Linear Way L</b> (page B-2 to page B-29) 8 types and 46 models	<b>Linear Way E</b> (page B-30 to page B-55) 18 types and 81 models
<b>Linear Way H</b> (page B-74 to page B-109) 14 types and 76 models	<b>Linear Way F</b> (page B-110 to page B-129) 4 types and 12 models
<b>Linear Roller Way Super X</b> (page C-2 to page C-33) 12 types and 84 models	
<b>Linear Ball Spline G</b> (page D-28 to page D-45) 8 types and 56 models	<b>Block type Linear ball Spline</b> (page D-46 to page D-53) 3 types and 17 models

### Features of interchangeable specification products [1]

#### Interchangeable slide unit

Various types of slide units with different sectional shapes and lengths are prepared. All of these slide units can be freely mounted on the same track rail.  
Track rails can be butt-jointed for use.(1)

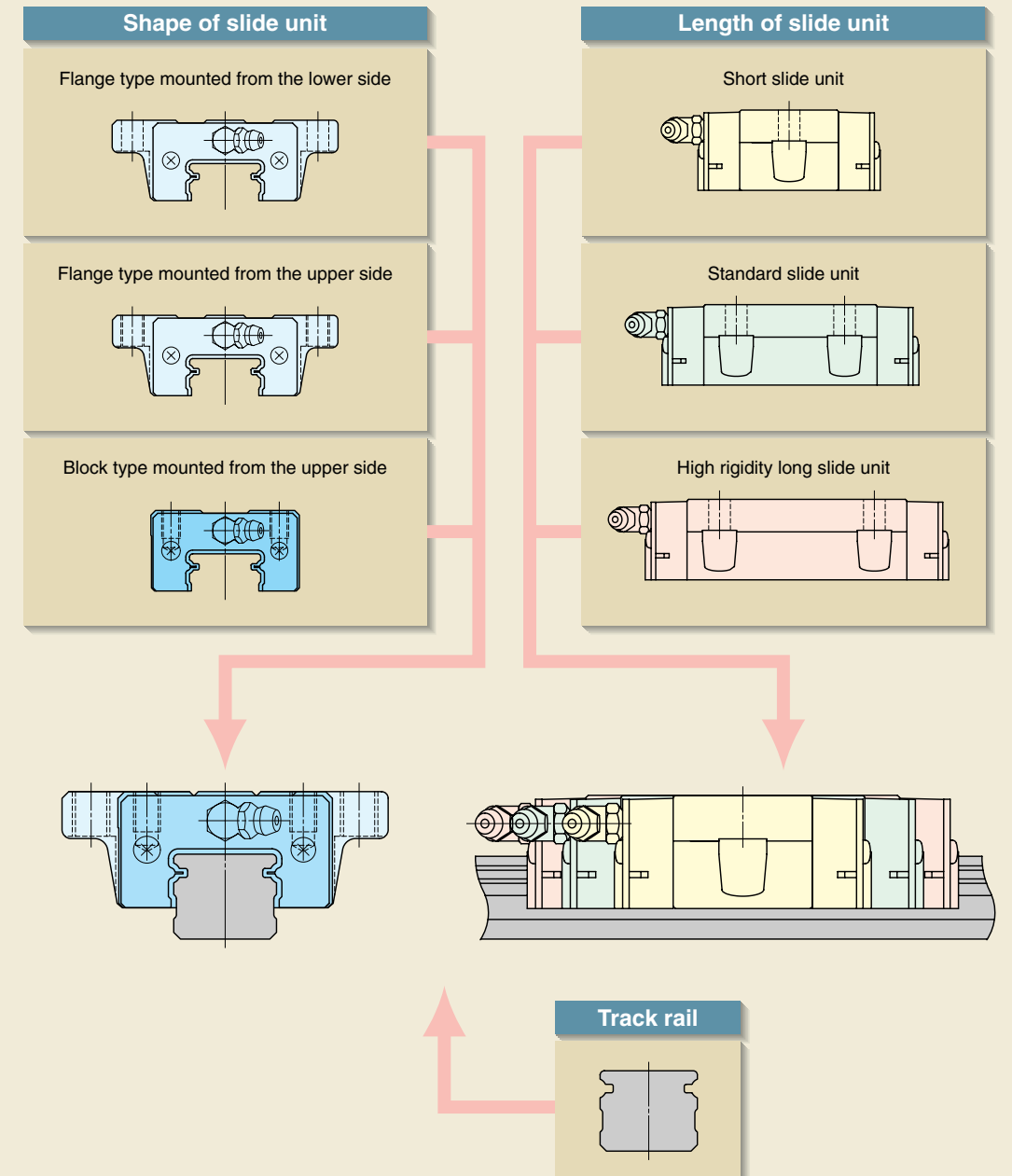

Note(1) : When butt-jointing track rails are required, place an order specifying "butt-jointing interchangeable track rail" of special specification.

**Features of interchangeable specification products [2]**  
**Interchangeable with high accuracy**

Three accuracy classes, Ordinary, High and Precision are prepared for the interchangeable specification products so that these products can be used for applications requiring high running accuracy.  
 Height variation among multiple sets is also controlled at a high accuracy level, ensuring that these products can be used for parallel track rail arrangement.

**Standard accuracy specifications : up to Precision class**

- Tolerances of Dimensions H and N
- Tolerances of Dimensions H and N in one set
- Parallelism in operation of plane C to plane A
- Parallelism in operation of plane D to plane B

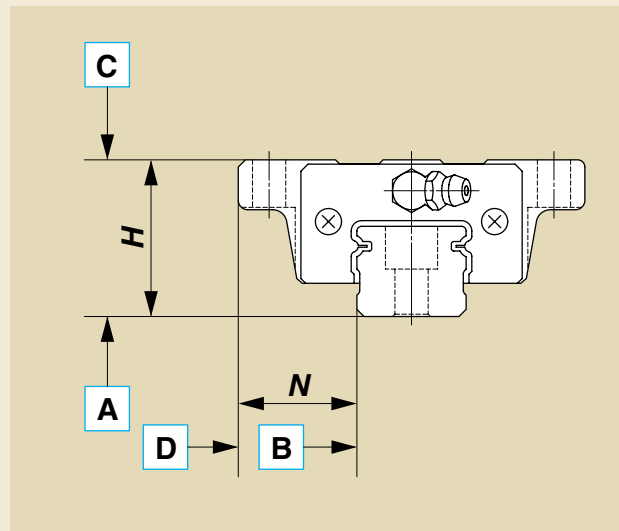

**Parallel arrangement of multiple sets using standard specification products**

The dimensional variation of H among multiple sets is specified.

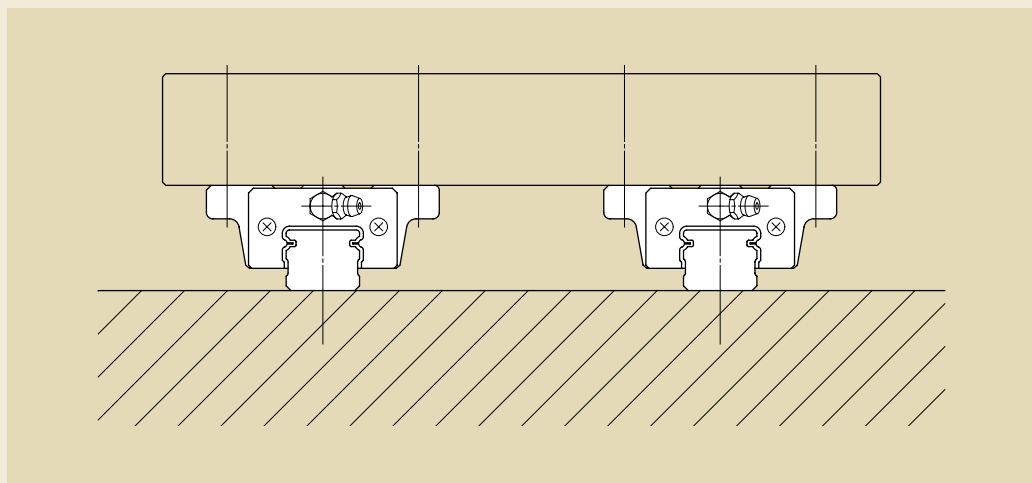

**Features of interchangeable specification products [3]**  
**Interchangeable with preload**

High accuracy dimensional control owing to a simple structure has made it possible to realize the interchangeability among preloaded slide units.  
 In the interchangeable specification products, several preload types are prepared so that these products can be used for applications requiring one step higher rigidity.

**High accuracy dimensional control realizing heavy preload**

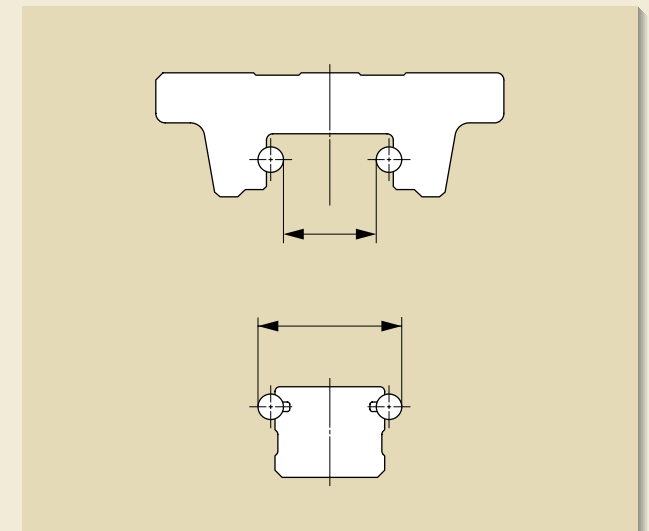

**Slide units with the same preload symbol are interchangeable for achieving high rigidity**

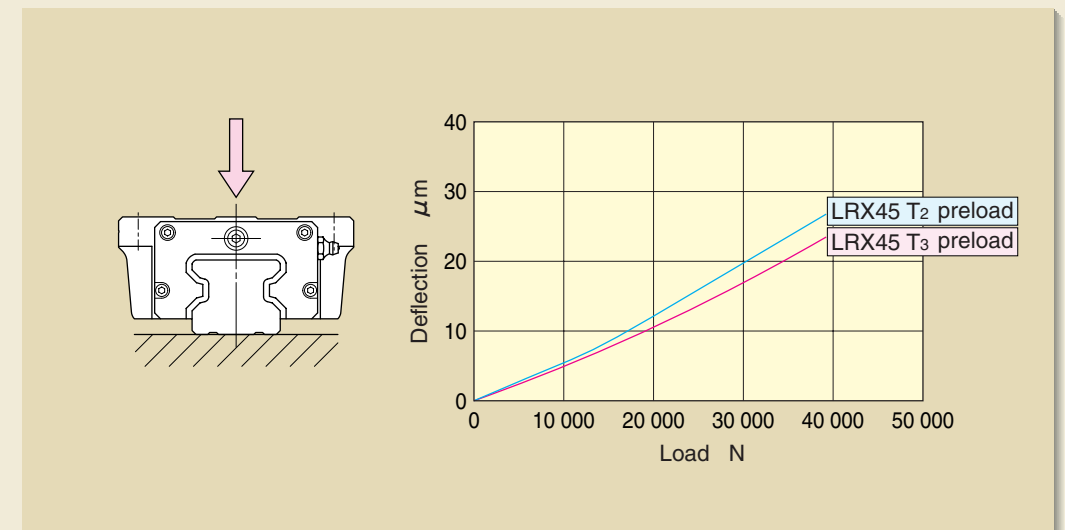

## Stainless Series

**IKO** Linear Way and Linear Roller Way include products in which stainless steel is used for product components. Stainless steel components are more resistant to corrosion than high carbon steel components, so these products are most suitable for applications where the use of oil or grease (including rust preventive oil) should be avoided or kept to a minimum. The stainless series is suitable for use in clean rooms and can be used with **IKO** Clean Grease to minimize dust generation.

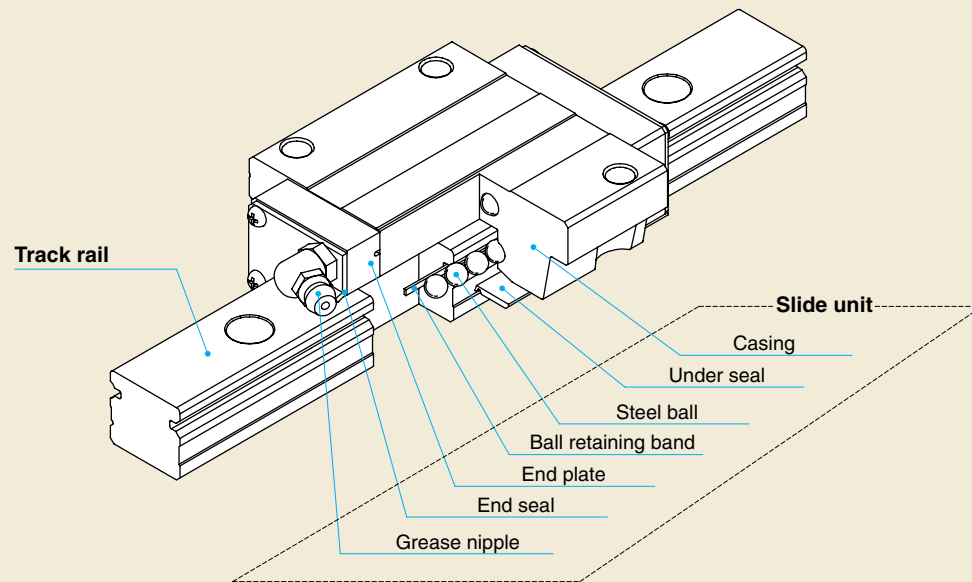

### Material

Part	Material
Track rail	Martensitic stainless steel
Casing	Martensitic stainless steel
Steel ball	Martensitic stainless steel
Ball retaining band	Austenitic stainless steel
End plate	Functional synthetic resin
End seal	Austenitic stainless steel + Synthetic rubber
Grease nipple	Brass

	Series		Reference page
C-Lube Linear Way	Miniature Maintenance Free Linear Way <b>C-Lube Linear Way ML</b>	This Linear Way incorporates the C-Lube as a component part for lubrication in Linear Way L. The lubricant contained in the C-Lube achieves long-term maintenance free operations, so the man-hours for troublesome lubrication control can be reduced.	A-2 ~
	Compact type Maintenance Free Linear Way <b>C-Lube Linear Way ME</b>	This Linear Way incorporates the C-Lube as a component part for lubrication in Linear Way E.	A-18 ~
	High rigidity Maintenance Free Linear Way <b>C-Lube Linear Way MH</b>	This Linear Way incorporates the C-Lube as a component part for lubrication in Linear Way H.	A-40 ~
	U-shaped Maintenance Free Linear Way <b>C-Lube Linear Way MUL</b>	This Linear Way incorporates the C-Lube as a component part for lubrication in Linear Way UL.	A-62 ~
Linear Way	Miniature Type Linear Way <b>Linear Way L</b>	This is the smallest in the <b>IKO</b> Linear Ways. This product is suitable for use in machines or equipment in clean rooms. Models with various track rail widths from as small as 2 mm are lined up.	B-2 ~
	Compact Type Linear Way <b>Linear Way E</b>	This is a compact type in comparison with Linear Way H and can be used for general purpose applications.	B-30 ~
	High Rigidity Type Linear Way <b>Linear Way H</b>	This type features large load ratings and high rigidity.	B-56 ~
	Wide Rail Type Linear Way <b>Linear Way F</b>	Being a wide rail type, it can support a large moment load acting around the axial direction, and it is also suitable for single row rail arrangement.	B-110 ~
	U-shaped Track Rail Linear Way <b>Linear Way U</b>	By adopting a U-shaped track rail, rigidity against moment and torsion is greatly improved.	B-130 ~
Linear Roller Way	<b>Linear Roller Way Super X</b>	For its rolling elements, this product employs cylindrical rollers, which provide very high rigidity and high accuracy.	C-2 ~

**When combined with the following special specifications, **IKO** Stainless series Linear Way and Linear Roller Way will provide a specification more suitable for each**

### **IKO** Low Dust Generation Grease for Clean Environment CG2 /YCG

**IKO** CG2 grease is a low dust generation grease consists of synthetic base oil and urea type thickener. This grease has superior performance for wide range of temperature, lubrication performance, rust prevention and oxidation stability.

### **IKO** Low Dust Generation Grease for Clean Environment CGL /YCL

**IKO** CGL grease has blended soaps for thickener and synthetic oil and petrolatum with low fluid point for base oil. In addition to its superior low dust generating, feature, it provides minimal level of rolling resistance as well as high lubricating and rust preventing performance.

### **IKO** Anti-Fretting Corrosion Grease AF2 /YAF

**IKO** AF2 grease is an Anti-Fretting Corrosion Grease consists of synthetic base oil and urea type thickener. It is suitable to very short stroke application that general grease cannot be used because of fretting corrosion or false brinelling.

### **Stainless Steel End Plate** /BS

A steel end plate (austenitic stainless steel) is used in place of the synthetic resin end plate of the standard specification. Linear Way and Linear Roller Way of this specification can be used in high vacuum and its heat resistance is improved as well. When placing an order for this item, specify it together with the special specification "With no end seal" (/N). A change in grease type to vacuum or heat-resistant grease should also be considered.

## Linear Way and Linear Roller Way for Special Environment

To meet requirements in various environmental conditions, **IKO** Linear Way and Linear Roller Way must be modified in terms of their material, lubricating grease, surface treatment, dust protection methods, etc.

General fields of application and principal methods in special environments are shown below.

### Clean Environment

When Linear Way and Linear Roller Way are used in clean environments such as a clean room, the environment must not be polluted by the dust generated from them, and also superior corrosion resistance is required for them, since rust preventive oil cannot be used.

Dust generation from Linear Way and Linear Roller Way is mainly caused by lubricant spattering, which can be avoided by using low dust generation grease for clean environment.

As a corrosion prevention measure, Stainless Linear Way and Linear Roller Way can be used or black chrome surface treatment can be performed to improve corrosion resistance.

#### Corrosion prevention

Stainless Linear Way and Linear Roller Way

Black chrome surface treatment

Fluorine black chrome surface treatment

#### Lubricant spatter protection

Low dust generation grease for clean environment

### Vacuum Environment

When Linear Way and Linear Roller Way are used in vacuum environments, the environment must not be polluted and the degree of vacuum must not be lowered by the gas emitted from them, and also superior corrosion resistance is required for them, since rust preventive oil cannot be used.

Gases emitted from synthetic resin components and lubricant spatters are the main causes of pollution. Components and lubricant must be properly selected as a preventive measure.

Corrosion resistance will be improved by using Stainless Linear Way and Linear Roller Way.

#### Corrosion and gas emission prevention

Stainless Linear Way and Linear Roller Way

Stainless steel end plate

#### Lubricant

Vacuum grease

### High Temperature

When Linear Way is used at high temperature, heat resistance of synthetic resin components and steel components must be examined, and special measures must be taken, if necessary.

Stainless Linear Way with stainless steel end plates of special specification can be used together with high temperature grease.

#### Material

Stainless Linear Way

Stainless steel end plate

Seal for special environment

#### Lubricant

High temperature grease

### Dust Protection

If foreign matter such as metal or wooden chips fall onto the raceways of Linear Way and Linear Roller Way, the life or accuracy of these guides may be affected adversely. Therefore, measures must be taken to prevent intrusion of foreign matter.

Bellows covering the entire linear motion mechanism is effective for dust protection. Also, double end seals are often used to protect the guides from intrusion of foreign matter. As dust accumulated in mounting holes may intrude into the slide unit and attach to the raceways, mounting holes can be covered using caps or rail cover plates.

#### High sealing performance

Linear Roller Way Super X

Linear Way H Ultra Sealed Type

#### Sealing

Double end seals

Scrapers

#### Track rail mounting hole

Caps

Rail cover plate

#### Bellows

Specially prepared bellows

Female threads for bellows

### Spatter Protection

Hot welding spatters adhering firmly on track rails cannot be removed by ordinary dust protection measures. Special measures for preventing adhesion and removing adhered spatters are necessary.

Welding spatters and similar foreign substances can be removed easily by applying fluorine black chrome surface treatment and providing a scraper at the same time.

#### Spatter adhesion protection

Fluorine black chrome surface treatment

#### Sealing

Scrapers

#### Dust protection

Caps (aluminum caps)

Rail cover plate

## Linear Way and Linear Roller Way for Special Environment

For applications in special environments requiring high corrosion resistance and high sealing performance, **IKO** provides Linear Way and Linear Roller Way for special environment as follows.

### Linear Way and Linear Roller Way for Special Environment

#### Rust prevention

Stainless steel components are used in place of common steel components for improving corrosion resistance.

#### High sealing specification

Precision grinding is applied to the entire contour surfaces of the track rail for improving the sealing performance.

Series		Reference page
Miniature Maintenance Free Linear Way	<b>C-Lube Linear Way ML</b> Stainless standard product	A-2 ~
Compact Type Maintenance Free Linear Way	<b>C-Lube Linear Way ME</b> Stainless standard product	A-18 ~
High rigidity Maintenance Free Linear Way	<b>C-Lube Linear Way MH</b> Stainless standard product	A-40 ~
U-shaped Maintenance Free Linear Way	<b>C-Lube Linear Way MUL</b> Stainless standard product	A-62 ~
Miniature Type Linear Way	<b>Linear Way L</b> Stainless standard product	B-2 ~
Compact Type Linear Way	<b>Linear Way E</b> Stainless specification product	B-30 ~
High Rigidity Type Linear Way	<b>Linear Way H</b> Stainless specification product	B-74 ~
Wide Rail Type Linear Way	<b>Linear Way F</b> Stainless specification product	B-110 ~
U-shaped Track Rail Linear Way	<b>Linear Way U</b> Stainless specification product	B-130 ~
	<b>Linear Roller Way Super X</b> Stainless specification product	C-2 ~
	<b>Linear Way H</b> Ultra sealed specification product	B-74 ~
	<b>Linear Roller Way Super X</b> Standard product, size 25 and upward	C-2 ~



## Optional Special Specifications for Special Environment

**IKO** Linear Way and Linear Roller Way with the following special specifications are available for various special environment applications. For details of supplemental codes, see pages 88 and 89.

### Dust protection

#### With caps for rail mounting holes /F

The caps prevent dust and other harmful foreign matter from accumulating in rail mounting holes and intruding into the slide unit.

Aluminum caps are also available. Consult **IKO** for further information.

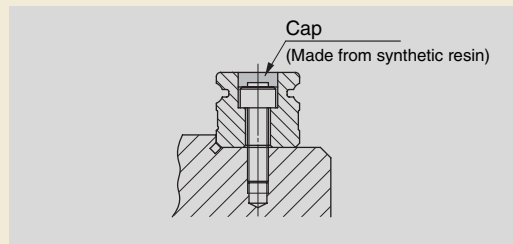

#### Rail cover plate /PS

The top surface of the track rail is completely covered with a rail cover plate to prevent intrusion of foreign matter into the slide unit from track rail mounting holes.

U.S. PATENT No. 5,622,433

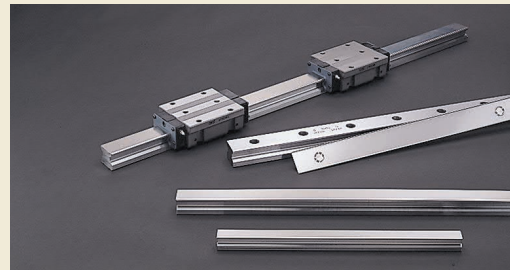

#### With double end seals /V

The double end seals improve the dust protection performance.

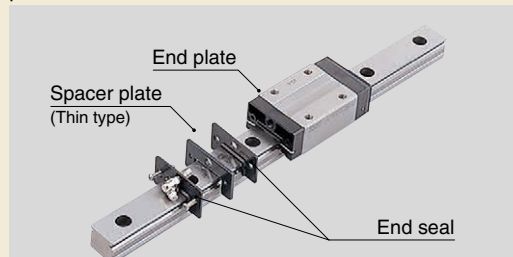

#### With scrapers /Z

Scrapers are mounted on the outside of end seals to remove large particles of dust or foreign matter that deposit on the track rail.

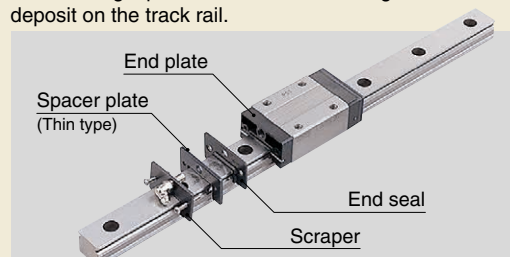

#### With female threads for bellows /J

Female threads for attaching bellows are provided at the ends of the slide unit and track rail.

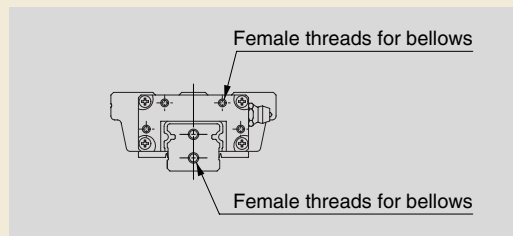

#### Bellows (available product)

This is a covering for dust protection to cover the exposed part of the track rail.

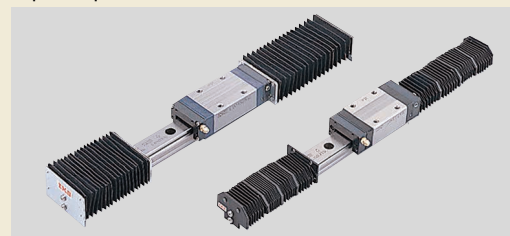

#### C-Wiper /RC

C-Wiper is the superior dust protective component against cutting chips and/or coolant of machine tool, lath and grinding machine. C-Wiper is always contacting to the top surface of track rail by its all wiping surface. Continuous dust protection performance provides better machine reliability under severe working condition.

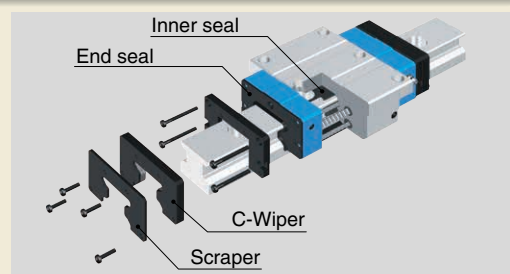

## Durability test results

### Durability test result under fine particles

Test condition	Product	MX 35 T <sub>3</sub> preload/FRC : C-Wiper specification
Operating speed		18 m/min
Travel length		500 mm
Dust condition		Fine metal particles Diameter of particle : 125 $\mu$ m or less Hardness of particle : HRC40 to 50 Application amount : 1 g/hr (Total volume : 1 kg)

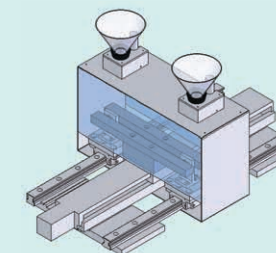

After 1,000km operation

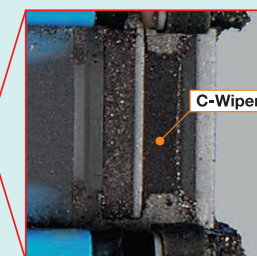
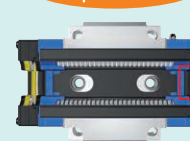

After 1,000km operation



**Steel particles inside of slide unit could be minimized.**

### Durability test result under coolant mist

Test condition	Product	MX 35 T <sub>3</sub> preload/FRC : C-Wiper specification
Operating speed		115.2 m/min
Travel length		300 mm
Coolant		Soluble type Diluting rate : $\times 20$ Spraying amount : 5cc

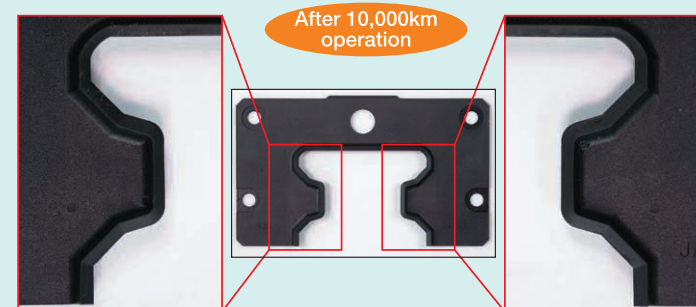
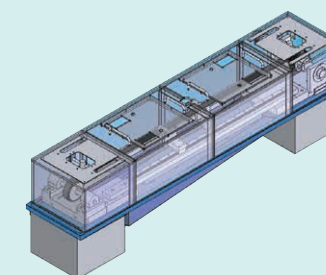

**No damage of end seal was found.**

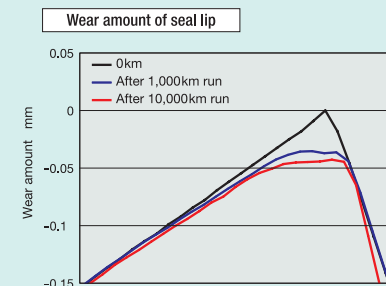

## Lubrication

### Capillary plate /Q

Re-lubrication interval can be made longer and maintenance time and cost can be saved by incorporating this lubrication part.

U.S. PATENT No. 6,190,046  
No. 6,176,617  
No. 6,082,899  
No. 5,967,667



### IKO Low Dust Generation Grease for Clean Environment CGL

This grease is used for low dust generation in clean rooms. Bellow type container JG80/CGL (80g) and miniature grease injector type MG2.5/CGL (2.5ml) are available.

JG80/CGL

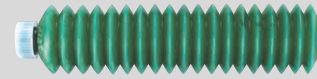

MG2.5/CGL



### IKO Low Dust Generation Grease for Clean Environment CG2

This grease is used for low dust generation in clean rooms. Bellow type container JG80/CG2 (80g), miniature grease injector type MG10/CG2 (10ml) and MG2.5/CG2 (2.5ml) are available.

JG80/CG2

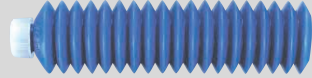

MG2.5/CG2



### IKO Anti-Fretting Corrosion Grease AF2

IKO AF2 grease is suitable to very short stroke application that general grease cannot be used because of fretting corrosion or false brinelling. Bellow type container JG80/AF2 (80g) and miniature grease injector type MG10/AF2 (10ml) are available.

JG80/AF2

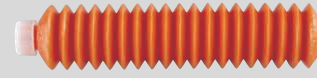

MG10/AF2



### Others

Miniature grease injector type for Alvania EP grease 2 (MG2.5/EP2) is available. When special grease is required for vacuum or high temperature, consult **IKO** for information.

## Corrosion prevention

### Black chrome surface treatment /L

A black chrome permeable film is formed on the track rail or slide unit surface to improve corrosion resistance.

### Fluorine black chrome surface treatment /LF

Fluorine resin coating is performed on top of the black chrome permeable film for further improvement in corrosion resistance. This treatment also effectively prevents foreign matter from adhering to the surface.



## Others

### With stainless steel end plates /BS

The end plates are replaced with stainless steel end plates.

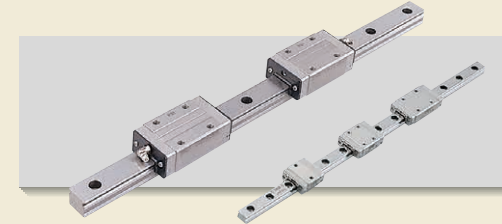

### With seals for special environment /RE

The end seals and under seals are changed to seals for special environment that can be used at high temperatures. For use at high temperatures, this specification is combined with the specification "with stainless steel end plates" (/BS) and/or "specified grease" (/YCG).

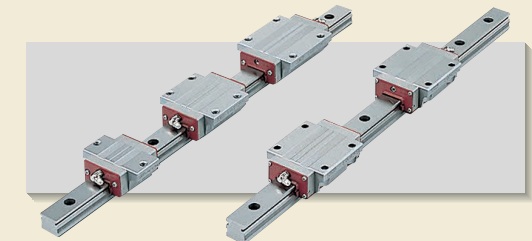

The photo shows a combined specification of "with seals for special environment" (/RE) and "with stainless steel end plates" (/BS).

# Identification Number

Identification numbers of **IKO** Linear Way and Linear Roller Way consist of a model code, a size, a part code, a material symbol, a preload symbol, a classification symbol, an interchangeable code, and any supplemental codes. Examples of identification numbers are shown below. For details of specifications, see the description of each series.

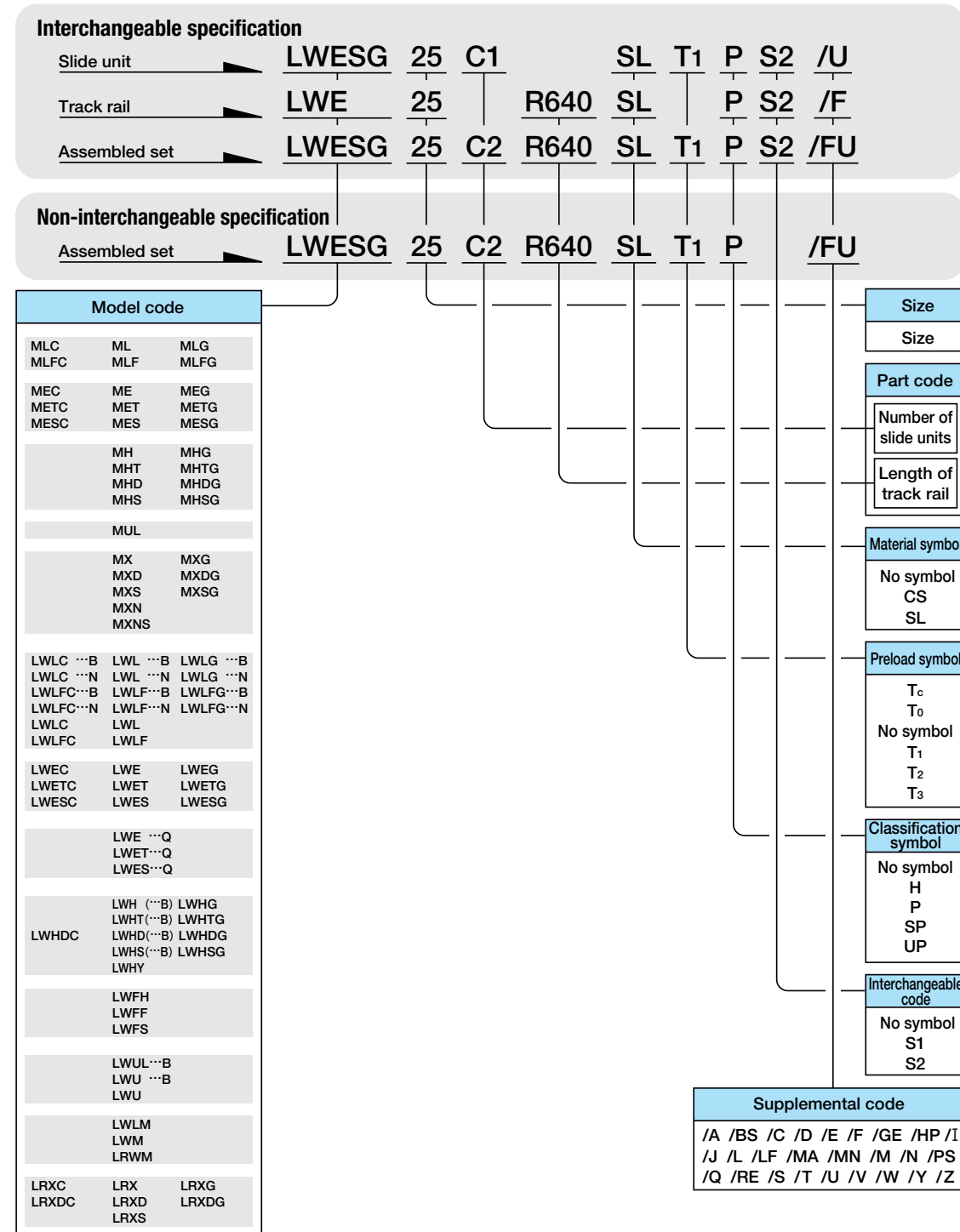

# For Ordering

When ordering assembled sets of Linear Way or Linear Roller Way, indicate the number of sets which is always represented by the number of track rails. For ordering the slide units and track rails of interchangeable specification separately, indicate the number of slide units and track rails, respectively. Examples of ordering are shown below.

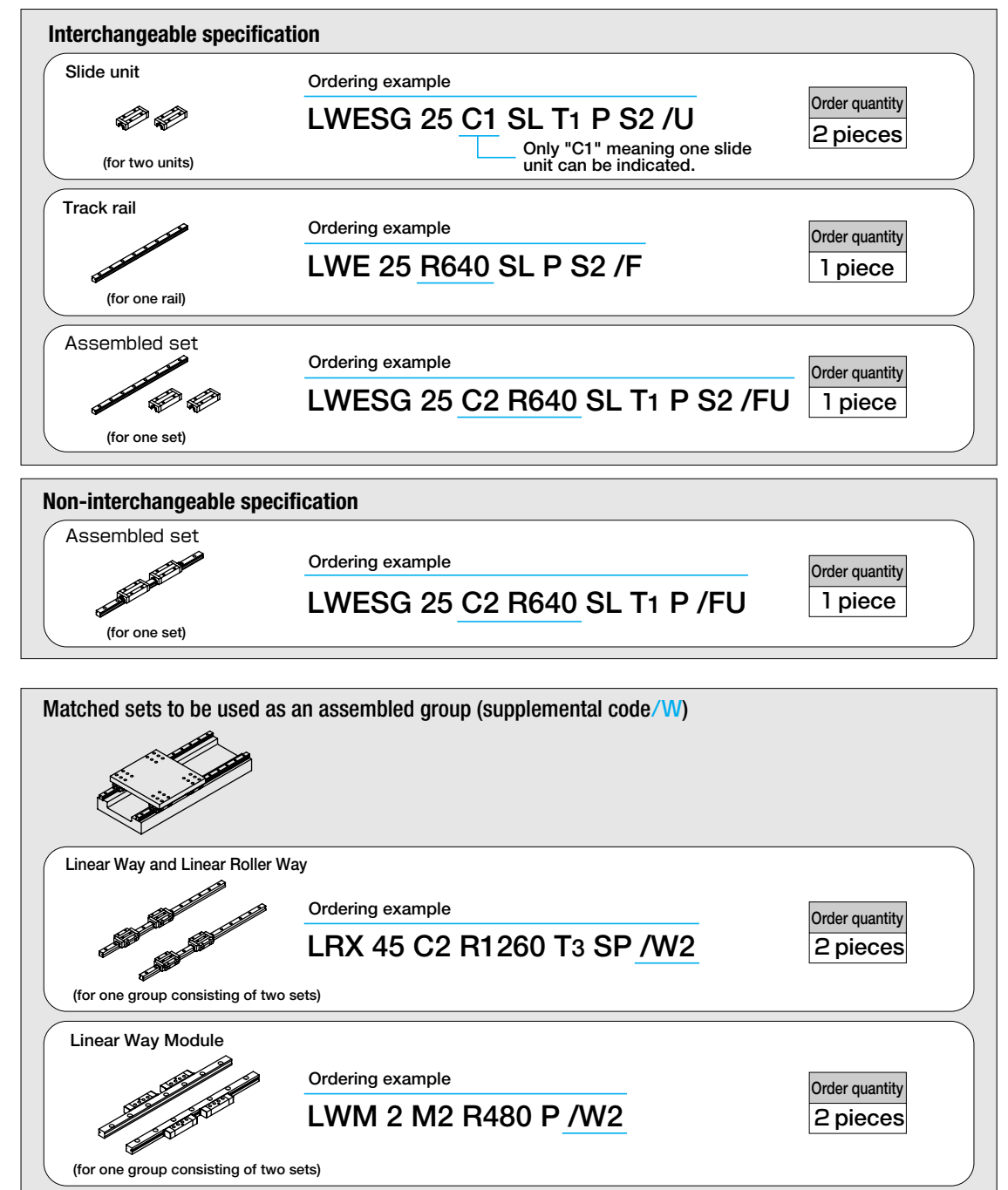

## Load Rating

The load ratings of **IKO** Linear Way and Linear Roller Way are defined for downward load. Summarized descriptions of load ratings are given below. For details of load rating definitions and load calculations, see "General description".

### Basic dynamic load rating $C$

The basic dynamic load rating is defined as the constant load both in direction and magnitude under which a group of identical Linear Ways or Linear Roller Ways are individually operated and 90% of the units in the group can travel  $50 \times 10^3$  meters free from material damage due to rolling contact fatigue.

### Basic static load rating $C_0$

The basic static load rating is defined as the static load that gives a prescribed constant contact stress at the center of the contact area between the rolling element and raceway receiving the maximum load.

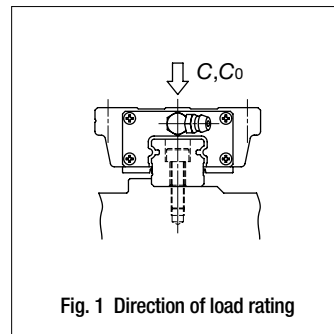

### Static moment rating $T_0, T_x, T_y$

The static moment rating is defined as the static moment load that gives a prescribed constant contact stress at the center of the contact area between the rolling element and raceway receiving the maximum load when a moment is loaded.

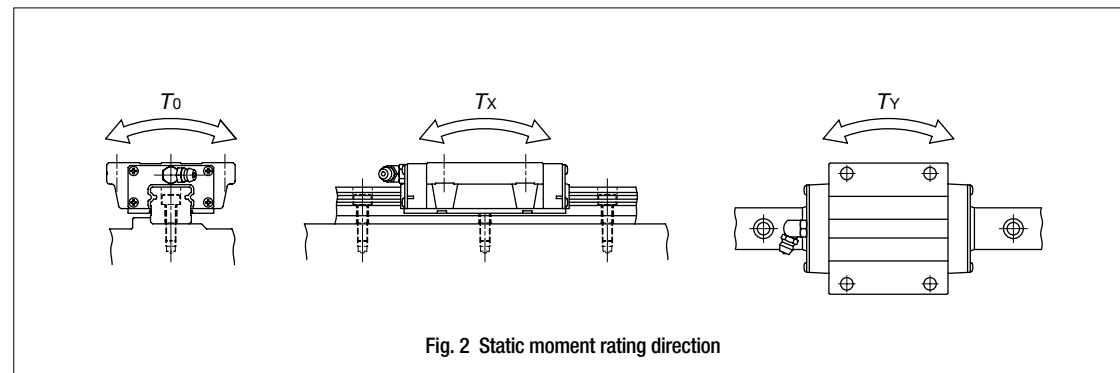

## Accuracy

Five classes of accuracy, Ordinary, High, Precision, Super Precision, and Ultra Precision are specified for **IKO** Linear Way and Linear Roller Way. Table 1 summarizes applicable accuracy classes for each series, and Tables 2.1 to 2.4 show accuracy of each series. For details of applicable classes, see the description of each series.

For the accuracy of series other than those shown in Table 2, consult **IKO** for further information.

Table 1 Accuracy classes

Series	Classification (symbol)	Ordinary (No symbol)	High (H)	Precision (P)	Super Precision (SP)	Ultra Precision (UP)
C-Lube Linear Way ML		—	☆	☆	—	—
C-Lube Linear Way ME		☆	☆	☆	○	—
C-Lube Linear Way MH		—	☆	☆	○	—
C-Lube Linear Way MUL		○	○	—	—	—
C-Lube Linear Roller Way Super MX		—	☆	☆	○	○
Linear Way L		—	☆	☆	—	—
Linear Way E		☆	☆	☆	○	—
Low Decibel Linear Way E		○	○	○	—	—
Linear Way H <sup>(1)</sup>		—	☆	☆	○	—
Linear Way F		—	☆	☆	○	—
Linear Way U		○	○	—	—	—
Linear Roller Way Super X		—	☆	☆	○	○
Linear Way Module		—	○	○	○	—

Note<sup>(1)</sup>: For the size 8 to 12 models, the classification for Linear Way L is applicable.

Remark: In the table, the mark ☆ indicates that it is also applicable to interchangeable specification products.

Table 2.1 Accuracy of Linear Way and Linear Roller Way

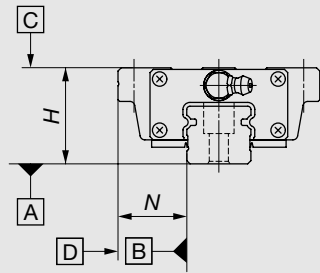

unit : mm

Item	Classification (symbol)	Ordinary (No symbol)	High (H)	Precision (P)	Super Precision (SP)	Ultra Precision (UP)
Dim. $H$ tolerance		$\pm 0.080$	$\pm 0.040$	$\pm 0.020$	$\pm 0.010$	$\pm 0.008$
Dim. $N$ tolerance		$\pm 0.100$	$\pm 0.050$	$\pm 0.025$	$\pm 0.015$	$\pm 0.010$
Dim. variation of $H$ (1)		0.025	0.015	0.007	0.005	0.003
Dim. variation of $N$ (1)		0.030	0.020	0.010	0.007	0.003
Dim. variation of $H$ for multiple assembled sets (2)		0.045	0.035	0.025	—	—
Parallelism in operation of C to A		See Fig. 3.1.				
Parallelism in operation of D to B		See Fig. 3.1.				

Note(1) : It means the size variation between slide units mounted on the same track rail.

(2) : It applies to the interchangeable specification products.

Remark 1 : The accuracy of C-Lube Linear Way ML, Linear Way L and the size 8 to 12 models of Linear Way H is shown in Table 2.2.

2 : The accuracy of Linear Way U and C-Lube Linear Way MUL is shown in Table 2.3.

3 : The accuracy of Linear Way Module is shown in Table 2.4.

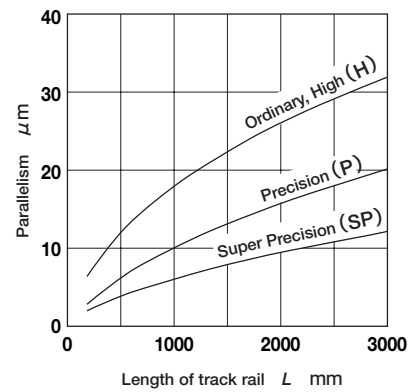

(a) Linear Way

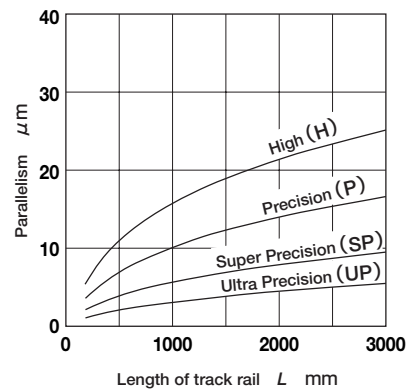

(b) Linear Roller Way

Fig. 3.1 Parallelism in operation of Linear Way and Linear Roller Way

Table 2.2 Accuracy of Linear Way L (size 2 or larger) and C-Lube Linear Way ML

unit : mm

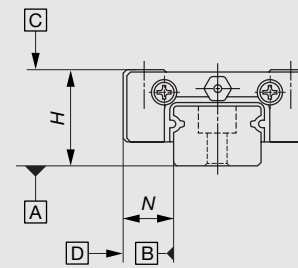

Item	Classification (Symbol)	High (H)	Precision (P)
Dim. $H$ tolerance		$\pm 0.020$	$\pm 0.010$
Dim. $N$ tolerance		$\pm 0.025$	$\pm 0.015$
Dim. variation of $H$ (1)		0.015	0.007
Dim. variation of $N$ (1)		0.020	0.010
Dim. variation of $H$ for multiple assembled sets (2)		0.030	0.020
Parallelism in operation of C to A		See Fig. 3.2.	
Parallelism in operation of D to B		See Fig. 3.2.	

Note(1) : It means the size variation between slide units mounted on the same track rail.

(2) : It applies to the interchangeable specification products.

Remark : The accuracy given in this table also applies to C-Lube Linear Way L and the size 8 to 12 models of Linear Way H.

Table 2.3 Accuracy of Linear Way L for LWL 1-Y

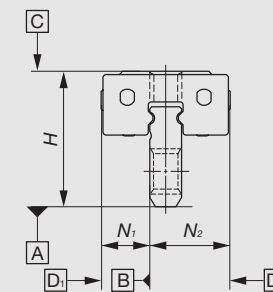

unit : mm

Item	Tolerance
Dim. $H$ tolerance	$\pm 0.020$
Dim. $N_1$ and $N_2$ tolerance	$\pm 0.025$

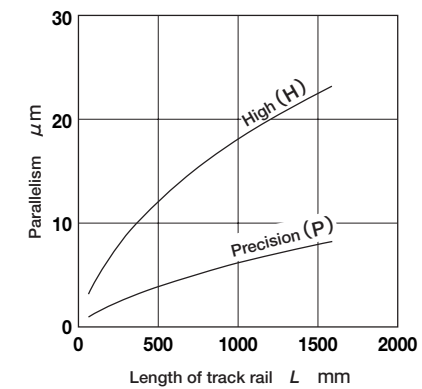
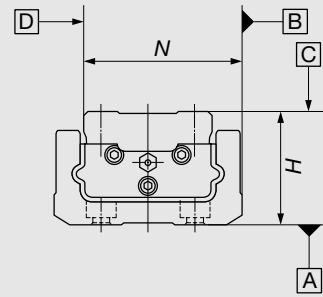

Fig. 3.2 Parallelism in operation of Linear Way L (Size 2 or larger) and C-Lube Linear Way ML

Table 2.4 Accuracy of Linear Way U



Item	Classification (Symbol)	unit : mm	
		Ordinary (No symbol)	High (H)
Dim. $H$ tolerance		$\pm 0.100$	$\pm 0.050$
Dim. $N$ tolerance		$\pm 0.100$	$\pm 0.050$
Dim. variation of $H^{(1)}$		0.050	0.040
Dim. variation of $N^{(1)}$		0.050	0.040
Parallelism in operation of C to A		See Fig. 3.3.	
Parallelism in operation of D to B		See Fig. 3.3.	

Note<sup>(1)</sup> : It means the size variation between slide units mounted on the same track rail.

Remark : Also applicable to C-Lube Linear Way MUL.

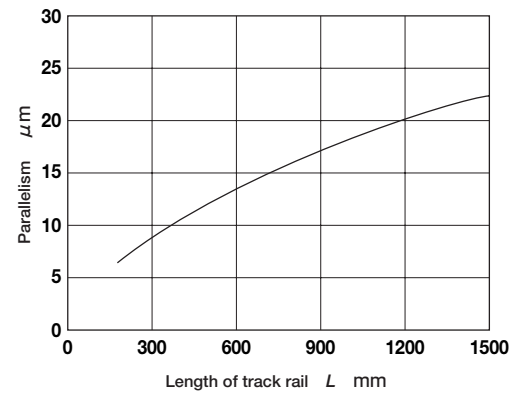
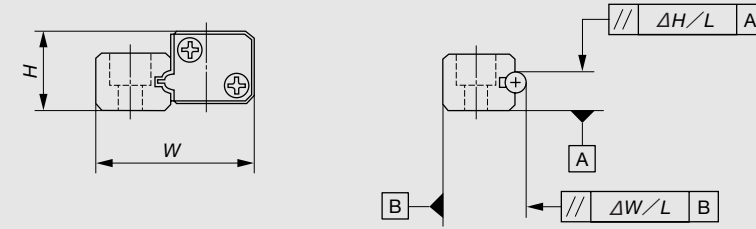

Fig. 3.3 Parallelism in operation of Linear Way U

Table 2.5 Accuracy of Linear Way Module



Item	Classification (symbol)	unit : mm		
		High (H)	Precision (P)	Super Precision (SP)
Dim. $H$ tolerance		$\pm 0.040$	$\pm 0.020$	$\pm 0.010$
Dim. $W$ tolerance		$\pm 0.050$	$\pm 0.025$	$\pm 0.015$
Dim. variation of $H^{(1)}$		0.015	0.007	0.005
Dim. variation of $W^{(1)}$		0.020	0.010	0.007
Parallelism of track rail $\Delta H$		See Figs. 3.4 and 3.5.		
Parallelism of track rail $\Delta W$		See Figs. 3.4 and 3.5.		

Note<sup>(1)</sup> : It means the size variation between slide members mounted on the same track rail.

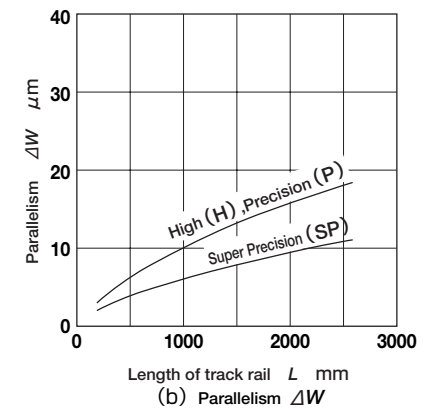
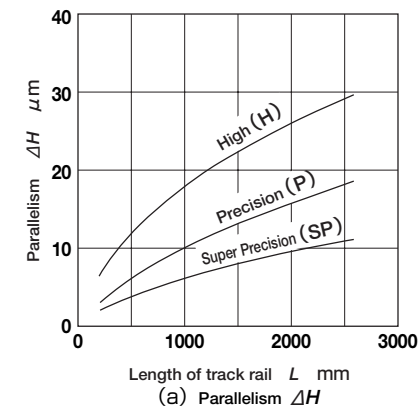

Fig. 3.4 Parallelism of Linear Way Module M

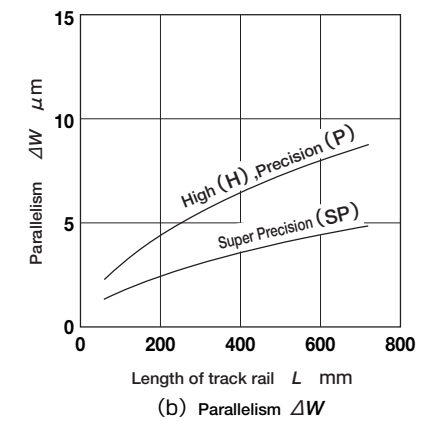
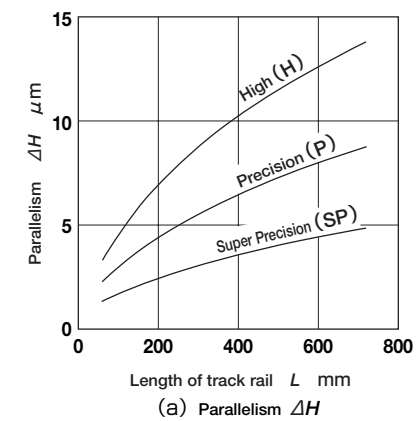

Fig. 3.5 Parallelism of Linear Way Module LM

## Preload

The average amount of preload for **IKO** Linear Way and Linear Roller Way is shown in Table 3. When both rigidity and vibration characteristics are important, the standard preload amount is 1/3 of the applied load for Linear Way and 1/2 for Linear Roller Way.

A summary of applicable preload types is shown in Table 4. For details, see the description of each series.

**Table 3 Preload amount**

Preload type	Item Symbol	Preload amount N	Application
Clearance	T <sub>C</sub>	0 (1)	<ul style="list-style-type: none"> <li>• Very smooth motion</li> <li>• To absorb slight misalignment</li> </ul>
	T <sub>0</sub>	0 (2)	<ul style="list-style-type: none"> <li>• Very smooth motion</li> </ul>
Standard	(No symbol)	0 (3)	<ul style="list-style-type: none"> <li>• Smooth and precise motion</li> </ul>
Light preload	T <sub>1</sub>	0.02C <sub>0</sub>	<ul style="list-style-type: none"> <li>• Minimum vibration</li> <li>• Load is evenly balanced.</li> <li>• Smooth and precise motion</li> </ul>
Medium preload	T <sub>2</sub>	0.05C <sub>0</sub>	<ul style="list-style-type: none"> <li>• Medium vibration</li> <li>• Medium overhung load</li> </ul>
Heavy preload	T <sub>3</sub>	0.08C <sub>0</sub>	<ul style="list-style-type: none"> <li>• Vibration and/or shocks</li> <li>• Large overhung load</li> <li>• Heavy cutting</li> </ul>

Note(1) : Clearance of about 10μm

(2) : Zero or minimal amount of clearance

(3) : Zero or minimal amount of preload

Remark : C<sub>0</sub> means the basic static load rating.

**Table 4 Preload type**

Series	Preload type (Symbol)	Clearance (T <sub>C</sub> )	Clearance (T <sub>0</sub> )	Standard (No symbol)	Light preload (T <sub>1</sub> )	Medium preload (T <sub>2</sub> )	Heavy preload (T <sub>3</sub> )
C-Lube Linear Way ML		—	☆	☆	☆	—	—
C-Lube Linear Way ME		☆	—	☆	☆	○	—
C-Lube Linear Way MH		—	—	☆	☆	○	○
C-Lube Linear Way MUL		—	—	○	○	—	—
C-Lube Linear Roller Way Super MX		—	—	☆	☆	☆	☆
Linear Way L		—	☆	☆	☆	—	—
Linear Way E		☆	—	☆	☆	○	—
Low Decibel Linear Way E		—	—	○	○	—	—
Linear Way H		—	○ (1)	☆	☆	☆	☆
Linear Way F		—	—	☆	☆	○	—
Linear Way U		—	—	○	○	—	—
Linear Roller Way Super X		—	—	☆	☆	☆	☆

Note(1) : It applies to size 8 to 12 models.

Remark : In the table, the mark ☆ indicates that it is also applicable to interchangeable specification products.

## Special Specifications

**IKO** Linear Way and Linear Roller Way of the special specifications shown in Table 5 are available. In some cases, however, special specifications may not be applicable. For details, see the description of each series. When a special specification is required, add the applicable supplemental code to the end of the identification number. When a combination of several special specifications is required, arrange their supplemental codes in alphabetical order.

**Table 5.1 Special specifications for Linear Way and Linear Roller Way**

Special specification	Supplemental code	C-Lube Linear Way ML	C-Lube Linear Way ME	C-Lube Linear Way MH	C-Lube Linear Way MUL	C-Lube Linear Roller Way Super MX	Linear Way L	Linear Way E	Low Decibel Linear Way E
Butt-jointing track rails (Non-interchangeable specification)	<b>A</b>	○	○	○	—	○	○	○	—
Stainless steel end plates	<b>BS</b>	—	—	—	—	—	○	☆	—
Chamfered reference surface	<b>C</b>	—	—	—	—	—	—	—	—
Opposite reference surfaces arrangement	<b>D</b>	☆	☆	☆	—	☆	☆	☆	○
Specified rail mounting hole positions	<b>E</b>	☆	☆	☆	○	☆	☆	☆	—
Caps for rail mounting holes	<b>F</b>	—	☆	☆	—	☆	—	☆	○
Changed pitch of slide unit middle mounting holes	<b>GE</b>	—	—	—	—	☆	—	—	—
Half pitch of track rail mounting holes	<b>HP</b>	—	—	—	—	☆	—	—	—
Inspection sheet (Non-interchangeable specification)	<b>I</b>	○	○	○	—	○	○	○	—
Female threads for bellows	<b>J</b>	—	☆	☆	—	☆	—	☆	—
Black chrome surface treatment	<b>L</b>	○	☆	☆	○	☆	○	☆	○
Fluorine black chrome surface treatment	<b>LF</b>	—	☆	☆	—	☆	○	☆	○
With track rail mounting bolt	<b>MA</b>	—	☆	☆	○	—	—	☆	○
Without track rail mounting bolt	<b>MN</b>	☆	—	☆	—	☆	☆	—	—
Change of mounting hole and female thread sizes	<b>M</b>	—	☆	—	—	—	○	☆	○
No end seal	<b>N</b>	☆	☆	☆	—	☆	☆	☆	—
Rail cover plate (Non-interchangeable specification)	<b>PS</b>	—	—	○	—	—	—	—	—
Capillary plate (Non-interchangeable specification)	<b>Q</b>	—	—	—	—	—	☆	☆	○
Seal for special environment	<b>RE</b>	—	—	—	—	—	○	☆	—
Track rail with stopper pins (Non-interchangeable specification)	<b>S</b>	○	—	—	—	—	○	—	—
Butt-jointing interchangeable track rail (Interchangeable specification)	<b>T</b>	—	☆	☆	—	☆	—	☆	—
Under seals	<b>U</b>	☆	☆	—	○	—	☆	☆	—
Double end seals	<b>V</b>	—	☆	☆	—	☆	—	☆	○
Matched sets to be used as an assembled group	<b>W</b>	○	○	○	○	○	○	○	○
Specified grease	<b>Y</b>	—	—	—	—	—	○	☆	○
Scrapers	<b>Z</b>	—	☆	☆	—	☆	—	☆	○

Note(1) : Including Linear Way LM and Linear Roller Way M.

Remark 1 : The mark ☆ indicates that interchangeable specification products are available.

2 : For the details of special specifications applicable to each series and combinations of special specifications, see the description of each series.

**Table 5.2 Special specifications for Linear Way and Linear Roller Way**

Special specification	Supplemental code	Linear Way H	Linear Way F	Linear Way U	Linear Roller Way Super X	Linear Way Module M(1)
Butt-jointing track rails (Non-interchangeable specification)	<b>A</b>	○	○	—	○	○
Stainless steel end plates	<b>BS</b>	☆	—	—	—	—
Chamfered reference surface	<b>C</b>	—	☆	—	—	—
Opposite reference surfaces arrangement	<b>D</b>	☆	☆	—	☆	—
Specified rail mounting hole positions	<b>E</b>	☆	☆	○	☆	○
Caps for rail mounting holes	<b>F</b>	☆	☆	—	☆	○
Changed pitch of slide unit middle mounting holes	<b>GE</b>	—	—	—	☆	—
Half pitch of track rail mounting holes	<b>HP</b>	—	—	—	☆	—
Inspection sheet (Non-interchangeable specification)	<b>I</b>	○	○	—	○	○
Female threads for bellows	<b>J</b>	☆	☆	—	☆	—
Black chrome surface treatment	<b>L</b>	☆	☆	○	☆	○
Fluorine black chrome surface treatment	<b>LF</b>	☆	☆	—	☆	○
With track rail mounting bolt	<b>MA</b>	—	—	○	—	—
Without track rail mounting bolt	<b>MN</b>	☆	☆	○	☆	○
Change of mounting hole and female thread sizes	<b>M</b>	—	—	—	—	—
No end seal	<b>N</b>	☆	☆	—	☆	—
Rail cover plate (Non-interchangeable specification)	<b>PS</b>	○	—	—	○	—
Capillary plate (Non-interchangeable specification)	<b>Q</b>	☆	☆	○	☆	—
C-Wiper	<b>RC</b>	—	—	—	○	—
Seal for special environment	<b>RE</b>	☆	—	—	—	—
Track rail with stopper pins (Non-interchangeable specification)	<b>S</b>	—	—	—	—	—
Butt-jointing interchangeable track rail (Interchangeable specification)	<b>T</b>	☆	—	—	☆	—
Under seals	<b>U</b>	☆	☆	○	—	—
Inner seal	<b>UR</b>	—	—	—	○	—
Double end seals	<b>V</b>	☆	☆	—	☆	—
Matched sets to be used as an assembled group	<b>W</b>	○	○	○	○	○
Specified grease	<b>Y</b>	☆	☆	—	☆	○
Scrapers	<b>Z</b>	☆	☆	—	☆	—

Note(1) : Including Linear Way LM.

Remark 1 : The mark ☆ indicates that interchangeable specification products are available.

2 : For the details of special specifications applicable to each series and combinations of special specifications, see the description of each series.



## Butt-jointing track rails /A



When the required length of non-interchangeable specification track rail exceeds the maximum length indicated in the description of each series, two or more track rails can be used by butt-jointing them in the direction of linear motion. For the length and the number of butt-jointing track rails, consult **IKO** for further information.

## With stainless steel end plates /BS

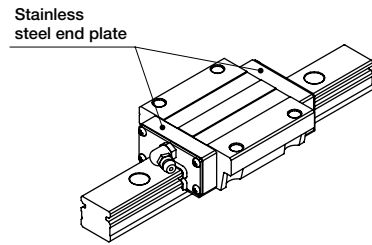

The standard synthetic resin end plates are replaced with stainless steel end plates, keeping the total length of slide unit unchanged. When superior heat resistance is required, it is recommended to apply this specification in combination with the "with no end seal (/N)" specification.

## Chamfered reference surface /C /CC

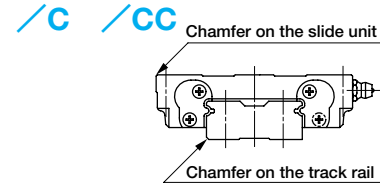

Chamfering is additionally made at the edges of reference mounting surfaces of slide unit and track rail. For the corner radius of mating mounting parts, see Table 23.2 on page 120.

① /C

Chamfering is additionally made at the edge of reference mounting surface of track rail.

② /CC

Chamfering is additionally made at the edges of reference mounting surfaces of slide unit and track rail.

## Opposite reference surfaces arrangement /D

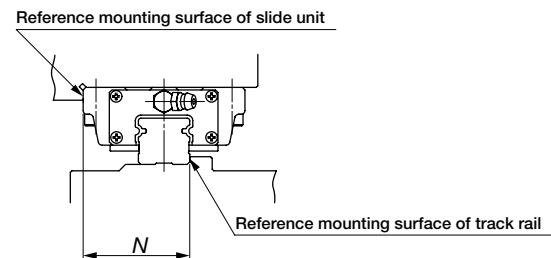

The reference mounting surface of track rail is made opposite to the standard side. The accuracy of dimension  $N$  including parallelism in operation is the same with that of standard specification.

## Specified rail mounting hole positions /E

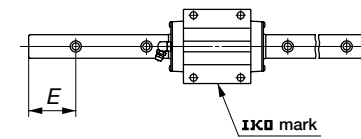

The mounting hole positions of track rail can be specified by specifying dimension  $E$  at the left end, which is the distance from the mounting hole nearest to the left end of the track rail to the left end face of the track rail in sight of **IKO** mark on the slide unit.

When ordering, add the dimension (in mm) after "/E".

Dimension  $E$  can be specified in a limited range. Consult **IKO** for further information.

## With caps for rail mounting holes /F

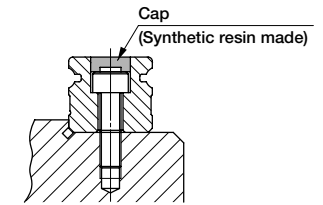

Specially prepared caps for track rail mounting holes are appended. These caps cover the track rail mounting holes to improve the sealing performance in the linear motion direction. Aluminum caps are also available. Consult **IKO** for further information.

## Changed pitch of slide unit middle mounting holes /GE

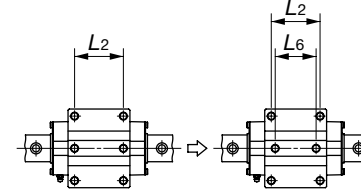

The pitch length between the two middle mounting holes of slide unit of Linear Roller Way Super X is changed. For this dimension, see the description of each series.

## Half pitch of track rail mounting holes /HP

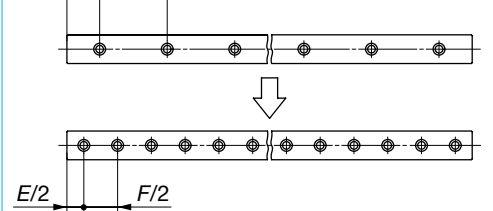

The pitch of the track rail mounting holes is changed to 1/2 of the dimension  $F$  of standard type. Track rail mounting bolts are appended in the same number as that of mounting holes.

## Inspection sheet /I

The inspection sheet recording dimensions  $H$  and  $N$ , dimensional variations of  $H$  and  $N$ , and parallelism in operation of the slide unit (or slide member) is attached for each set.

## Ceramic ball specification /HB

Silicon nitride ceramics balls are incorporated in the slide unit to realize high-speed operation and low running noise. In addition, the rigidity has been improved because of the minimal elastic deformation of ceramic characteristic.

With female threads for bellows (for single slide unit or track rail) /J /JR /JL

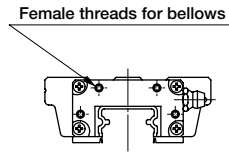

Slide unit

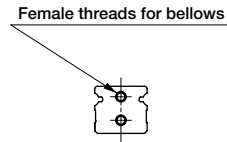

Track rail

Female threads for mounting bellows are provided on the interchangeable slide unit or the interchangeable track rail. For details of related dimensions, see the description of each series.

① /J

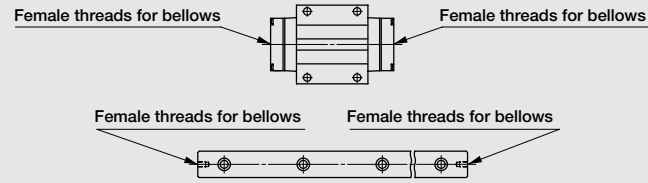

Female threads are provided at both ends of the slide unit or the track rail.

② /JR

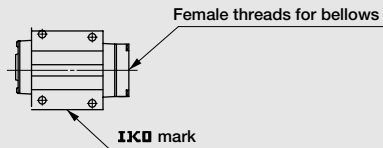

Female threads are provided at the right end of the slide unit in sight of **IKO** mark.

③ /JL

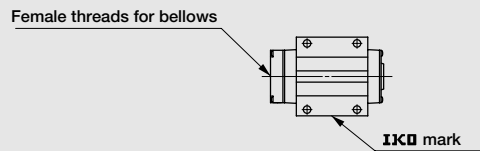

Female threads are provided at the left end of the slide unit in sight of **IKO** mark.

With female threads for bellows (for assembled set) /J /JJ /JR /JS /JJS

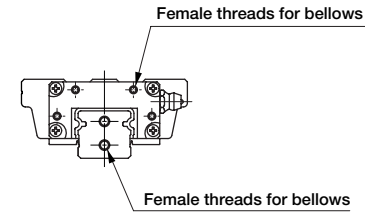

For an assembled set of interchangeable or non-interchangeable specification, female threads for mounting bellows are provided on the slide unit and the track rail. For details of related dimensions, see the description of each series.

① /J

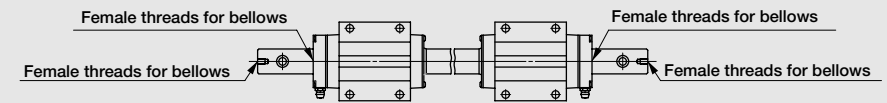

Female threads are provided at both ends of the track rail, and at the slide unit ends which are the closest to the track rail ends. (In case only one slide unit is assembled, female threads are provided at both ends.)

② /JJ

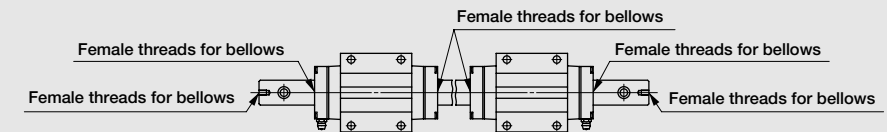

Female threads are provided at both ends of the track rail, and at all ends of all slide units. (Applicable, when the number of slide units is two or more. In case only one slide unit is assembled, indicate "/J".)

③ /JR

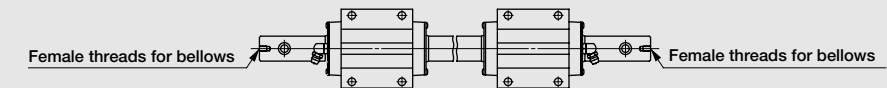

Female threads are provided at both ends of the track rail.

④ /JS

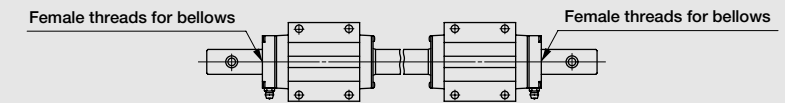

Female threads are provided at the slide unit ends which are the closest to the track rail ends. (In case only one slide unit is assembled, female threads are provided at both ends.)

⑤ /JJS

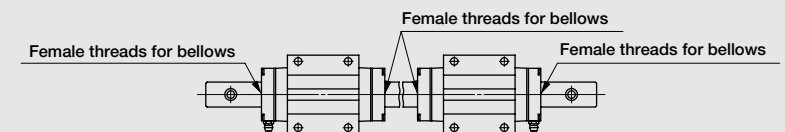

Female threads are provided at all ends of all slide units. (Applicable, when the number of slide units is two or more. In case only one slide unit is assembled, indicate "/JS".)

### Black chrome surface treatment

/LC /LR /LCR

After forming a black permeable chrome film, the surface is coated with acrylic resin for improvement in corrosion resistance.

- ① /LC  
Treatment is applied to the casing.
- ② /LR  
Treatment is applied to the track rail.
- ③ /LCR  
Treatment is applied to the casing and the track rail.

### Fluorine black chrome surface treatment

/LFC /LFR /LFCR

U.S. PATENT NO. 5,564,188  
NO. 5,374,126

After forming a black permeable chrome film, the surface is coated with fluorine resin for further improvement in corrosion resistance. This treatment is also effective in preventing the adhesion of foreign substances on the surface.

- ① /LFC  
Treatment is applied to the casing.
- ② /LFR  
Treatment is applied to the track rail.
- ③ /LFCR  
Treatment is applied to the casing and the track rail.

### With track rail mounting bolts

/MA<sup>(1)</sup>

Track rail mounting bolts are appended according to the number of mounting holes.

### Without track rail mounting bolts

/MN<sup>(1)</sup>

Track rail mounting bolts are not appended.

### Change of mounting hole size and female thread size /M2<sup>(1)</sup> /M3<sup>(1)</sup> /M4<sup>(1)</sup>

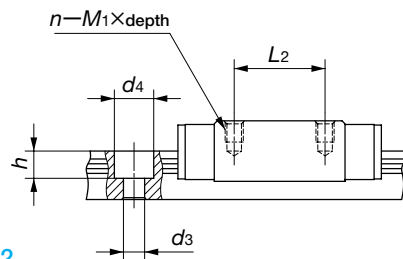

The size of the female threads for mounting the slide unit or the size of the track rail mounting hole is changed. For dimensions, see the description of each series.

- ① /M2  
The female threads for mounting the LWL5 slide unit are changed to M2.
- ② /M3  
The female threads for mounting LWL9 and LWL12 slide units are changed to M3, and the track rail mounting holes are changed to holes for M3.  
The female threads for mounting LWLF14 and LWLF18 slide units are changed to M3.
- ③ /M4  
The track rail mounting holes for M3 of LWE15 are changed to holes for M4.

Note<sup>(1)</sup>: For assembling /MA, /MN, /M2, /M3, /M4, please indicate as shown below.  
Combination of /MA and /M4: /MA4  
Combination of /MN and /M2: /MN2  
Combination of /MN and /M3: /MN3

### No end seal /N

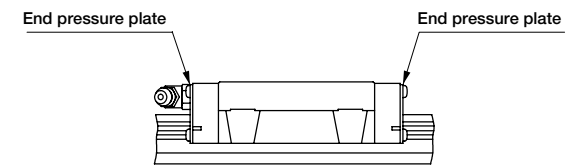

End seals at both ends of slide unit are replaced by end pressure plates (not in contact with the track rail) to reduce frictional resistance. The under seals are not assembled. This specification is not effective for dust protection.

### Rail cover plate /PS

U.S. PATENT NO. 5,622,433

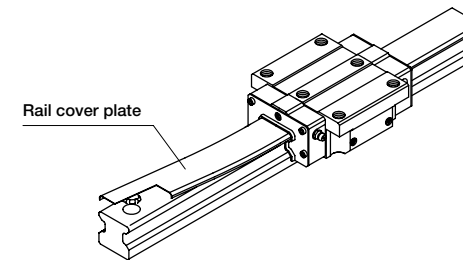

After mounting the track rail, the top surface of track rail is covered with a U-shaped thin stainless steel plate for further improvement in sealing performance. The rail cover plate is delivered as assembled on the track rail. Standard end seals must be replaced with the special end seals. When mounting the cover plate, refer to the attached instruction manual for rail cover plate.

### Capillary plate /Q

U.S. PATENT NO. 6,190,046  
NO. 6,176,617  
NO. 6,082,899  
NO. 5,967,667

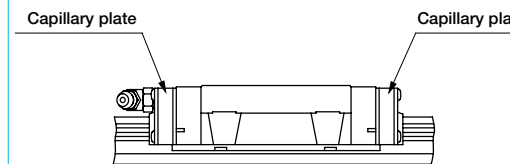

The capillary plate is assembled inside the end seal of the slide unit. It is impregnated with lubricant so that re-lubrication interval can be made longer. For the total length of the slide unit with capillary plate, see the description of each series.

### Track rail with stopper pins /S

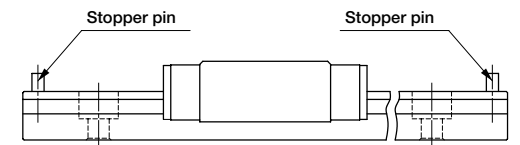

To prevent the slide unit of Linear Way L from slipping off, a stopper pin is provided at both ends of the track rail. For related dimensions, see the description of Linear Way L.

### Seal for special environment /RE

The standard end seals and under seals are changed to seals for special environment that can be used at high temperature.

### C-Wipers /RC /RCC

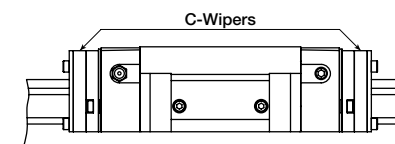

C-Wipers are attached on the slide unit for additional dust protection. The slide unit with C-Wipers has also Inner Seal (/UR) and Scraper. Total lengths of slide unit with C-Wipers are shown in Table 9.

- ① /RC  
C-Wipers are provided at the ends of slide units which are closest to the end of the track rail. In case only one slide unit is assembled, C-Wipers are provided at the both ends of side unit.
- ② /RCC  
C-Wipers are provided at both ends of all slide units. Applicable when the number of slide units to be two or more. In case one slide unit, indicate "/RC".

### Butt-jointing interchangeable track rail (for interchangeable specification) /T

A special interchangeable track rail of which both ends are finished for butt-jointing is provided. Use the track rails having the same interchangeable code for butt-jointing. For the non-interchangeable specification, indicate "butt-jointing track rail (/A)".

### With under seals /U

U.S. PATENT NO. 5,464,288  
NO. 5,356,223  
NO. 5,324,116  
NO. 5,306,089  
NO. 5,209,575

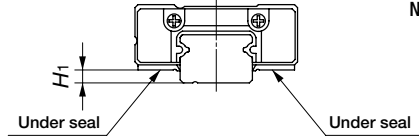

To prevent foreign substances intruding from the lower side of Linear Way, seals are provided on the bottom faces of slide unit. For size H1, see the description of each series.

### With upper seals /U

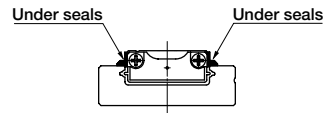

For C-Sleeve Linear Way MUL and Linear Way LWUL, rubber seals are attached to upper side face of the slide unit to prevent foreign materials from entering from the upper side. For dimensions with upper seals, please see the description of each series.

### Inner seals /UR

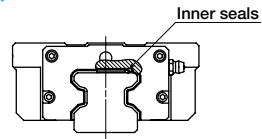

Inner seals are provided inside of slide unit, where recirculation area is effectively protected from dust collected on upper surface of track rail.

### With double end seals (for single slide unit) /V /VR /VL

Double end seals are provided on the interchangeable slide unit for more effective dust protection. For the total length of the slide unit with double end seals, see the description of each series.

- ① /V  
Double end seals are provided at both ends of the slide unit.
- ② /VR  
Double end seals are provided at the right end of the slide unit in sight of **IKO** mark.
- ③ /VL  
Double end seals are provided at the left end of the slide unit in sight of **IKO** mark.

### With double end seals (for assembled set) /V /W

Double end seals are provided on the slide unit of assembled set of interchangeable specification or non-interchangeable specification for more effective dust protection. For the total length of the slide unit with double end seals, see the description of each series.

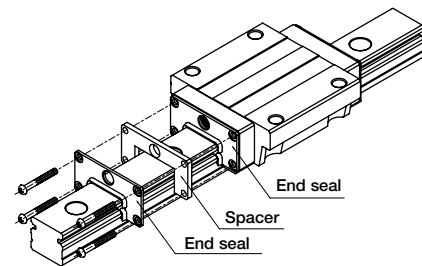

- ① /V  
Double end seals are provided at the ends of slide units which are the closest to the ends of the track rail. (In case only one slide unit is assembled, double end seals are provided at both ends.)
- ② /W  
Double end seals are provided at all ends of all slide units. (Applicable when the number of slide units is two or more. In case only one slide unit is assembled, indicate "/V".)

### Matched sets to be used as an assembled group /W

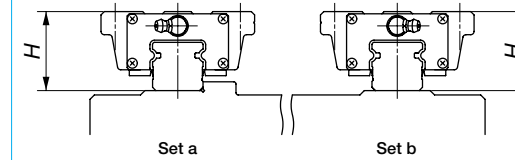

For two or more sets of Linear Way or Linear Roller Way used on the same plane, the dimensional variation of H of Linear Way or Linear Roller Way is kept within the specified range. The dimensional variation of dimension H in matched sets is the same as that of a single set. Indicate the number of sets after "/W". Order the number of sets in a group. Please refer Page 80 for ordering.

### Specified grease

#### /YCG/YCL/YAF/YBR/YNG

The type of pre-packed grease in the slide unit can be changed by a supplemental code. Rust preventive oil is applied.

- ① /YCG **IKO** Low Dust Generation Grease for Clean Environment CG2 is pre-packed.
- ② /YCL **IKO** Low Dust Generation Grease for Clean environment CGL is pre-packed.
- ③ /YAF **IKO** Anti-Fretting Corrosion Grease AF2 is pre-packed.
- ④ /YBR MOLYCOTE BR2 Plus Grease (Dow Corning) is pre-packed.
- ⑤ /YNG No grease is pre-packed.

### With scrapers (for single slide unit) /Z /ZR /ZL

Metal scrapers are provided on the slide unit of interchangeable specification. The scraper (non-contact type) is used to effectively remove large particles of dust or foreign matter adhering to the track rail. For the total length of the slide unit with scrapers, see the description of each series.

- ① /Z  
Scrapers are provided at both ends of the slide unit.
- ② /ZR  
A scraper is provided at the right end of the slide unit in sight of **IKO** mark.
- ③ /ZL  
A scraper is provided at the left end of the slide unit in sight of **IKO** mark.

### With scrapers (for assembled set) /Z /ZZ

Metal scrapers are provided on the slide unit of assembled set of interchangeable specification or non-interchangeable specification. The scraper (non-contact type) is used to effectively remove large particles of dust or foreign matter adhering to the track rail. For the total length of the slide unit with scrapers, see the description of each series.

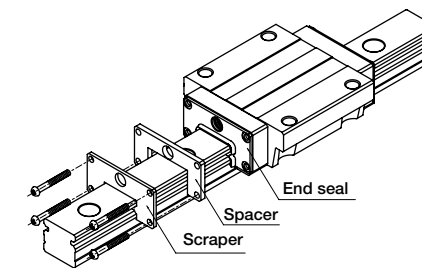

- ① /Z  
Scrapers are provided at the ends of slide units which are the closest to the ends of the track rail. (In case only one slide unit is assembled, scrapers are provided at both ends.)
- ② /ZZ  
Scrapers are provided at all ends of all slide units. (Applicable when the number of slide units is two or more. In case only one slide unit is assembled, indicate "/Z".)

## Lubrication and Dust Protection

**IKO** Linear Way and Linear Roller Way are most generally lubricated with grease, which allows for easy lubrication control. A grease nipple for grease replenishment is provided on each slide unit of Linear Way and Linear Roller Way of standard specification (except some models). Parts such as piping joints are also available, and can be delivered if required.

**IKO** Linear Way and Linear Roller Way are provided with special rubber seals for dust protection. But, if a large amount of fine contaminants are present, or if large particles of foreign matter may fall on the track rail, it is recommended to provide bellows and other protective covers.

The size 2, 3, 4, and 6 models of Linear Way L are not provided with seals.

### Pre-packed grease

A high quality lithium-soap base grease shown in Table 6 is pre-packed in **IKO** Linear Way and Linear Roller Way. A special grease can be pre-packed by specifying "Specified grease" of the special specification on page 97. For the interval and amount of grease replenishment, see "General description".

Table 6 Pre-packed grease list

Series	Pre-packed grease
C-Lube Linear Way ML	MULTEMP PS No.2 (KYODO YUSHI)
C-Lube Linear Way ME	ALVANIA EP GREASE 2 (SHELL)
C-Lube Linear Way MH	
C-Lube Linear Way MUL	MULTEMP PS No.2(KYODO YUSHI)
C-Lube Linear Roller Way Super MX	ALVANIA EP GREASE 2(SHELL)
Linear Way L	MULTEMP PS No.2(KYODO YUSHI)
Linear Way E	ALVANIA EP GREASE 2 (SHELL)
Low Decibel Linear Way E	
Linear Way H <sup>(1)</sup>	
Linear Way F	
Linear Way U <sup>(2)</sup>	
Linear Roller Way Super X	
Linear Way Module	

Note<sup>(1)</sup>: For size 8 to 12 models, MULTEMP PS No.2 is pre-packed.  
<sup>(2)</sup>: For size 25 and 30 models, MULTEMP PS No.2 is pre-packed.

### Parts for lubrication

**IKO** Linear Way and Linear Roller Way are provided with a grease nipple or oil hole for grease replenishment. Table 7 shows parts for lubrication applicable to each series. However, Linear Way L Ball Non-retained type is not provided a grease nipple and oil hole. For re-lubrication of this type, apply grease directly to the raceways of the track rail.

Table 7.1 Parts for lubrication

Series	Model code	Size	Grease nipple		Nominal size of female threads for piping		
			Type	Applicable supply nozzle type			
C-Lube Linear Way ML	ML	5 7 9 12	Oil hole	Mini-grease injector	-		
		15 20	A-M3	A-5120V A-5240V B-5120V B-5240V	-		
		25	B-M4	A-8120V B-8120V	M4		
	MLF	10 14 18 24	Oil hole	Mini-grease injector	-		
		30 42	A-M3	A-5120V A-5240V B-5120V B-5240V	-		
		15	A-M4	A-5120V A-5240V B-5120V B-5240V	M4		
C-Lube Linear Way ME	ME	20 25 30	B-M6	Grease gun available on the market	M6		
		35 45	JIS 4 type		PT1/8		
		8 10	Oil hole	Mini-grease injector	-		
C-Lube Linear Way MH	MH	12	A-M3	A-5120V A-5240V B-5120V B-5240V	-		
		15	A-M4	A-5120V A-5240V B-5120V B-5240V	-		
		20 25 30	B-M6	Grease gun available on the market	M6		
		35 45			PT1/8		
		C-Lube Linear Way MUL	MUL	25 30	Oil hole	Mini-grease injector	-
				15	A-M4	A-5120V A-5240V B-5120V B-5240V	M4
C-Lube Linear Roller Way Super MX	MX	20 25	B-M4	A-8120V B-8120V	M4		
		30	B-M6	Grease gun available on the market	M6		
		35	JIS 1 type		PT1/8		
		45 55 65	JIS 2 type				
		Linear Way L Ball Retained type	LWL ...B	5 7 9 12	Oil hole	Mini-grease injector	-
15 20	A-M3			A-5120V A-5240V B-5120V B-5240V	-		
25	B-M4			A-8120V B-8120V	M4		
LWLF...B	10 14 18 24		Oil hole	Mini-grease injector	-		
	30 42		A-M3	A-5120V A-5240V B-5120V B-5240V	-		
	15		A-M4	A-5120V A-5240V B-5120V B-5240V	M4		
Linear Way E	LWE	20 25 30	B-M6	Grease gun available on the market	M6		
		35 45	JIS 4 type		PT1/8		
		15	A-M4	A-5120V A-5240V B-5120V B-5240V	M4		
Low Decibel Linear Way E	LWE...Q	20 25 30	B-M6	Grease gun available on the market	M6		
		35	JIS 4 type		PT1/8		

Remark : The above table shows representative model codes, but is applicable to all other models.  
 When "Oil hole" is described in the grease nipple column, an oil hole is provided in place of a grease nipple.

Table 7.2 Parts for lubrication

Series	Model code	Size	Grease nipple		Nominal size of female threads for piping
			Type	Applicable supply nozzle type	
Linear Way H	LWH...B	8 10	Oil hole	Mini-grease injector	-
		12	A-M3	A-5120V A-5240V B-5120V B-5240V	-
		15	A-M4	A-5120V A-5240V B-5120V B-5240V	M4
		20 25 30	B-M6		M6
		35 45 55 65 85	JIS B type	Grease gun available on the market	PT1/8
Linear Way F	LWFH	40 60 90	JIS A-M6F		M6
	LWFF LWFS	33	A-M3	A-5120V A-5240V B-5120V B-5240V	-
		37	A-M4	A-5120V A-5240V B-5120V B-5240V	M4
	LWUL...B	42 69	B-M6	Grease gun available on the market	M6
		25 30	Oil hole	Mini-grease injector	-
Linear Way U	LWU...B LWU	40 50	A-M4	A-5120V A-5240V B-5120V B-5240V	M4
		60 86 100 130	JIS A-M6F	Grease gun available on the market	M6
	Linear Roller Way Super X	LRX	12	A-M3	A-5120V A-5240V B-5120V B-5240V
15			A-M4	A-5120V A-5240V B-5120V B-5240V	M4
20 25			B-M4	A-8120V B-8120V	M4
30			B-M6		M6
35			JIS A-M6F	Grease gun available on the market	M6
45 55 65 85 100			JIS A-PT1/8 JIS A-PT1/4		PT1/8 PT1/4

Remark : The above table shows representative model codes, but is applicable to all other models.  
When "Oil hole" is described in the grease nipple column, an oil hole is provided in place of a grease nipple.

## Oil hole

Some models of C-Lube Linear Way ML, C-Lube Linear Way MUL, Linear Way L Ball Retained type and Linear Way H are provided with an oil hole as shown in Table 8. (See also Table 7.) For grease replenishment, use a syringe type dispenser. The specially prepared miniature greaser is also available.

Table 8 Oil hole

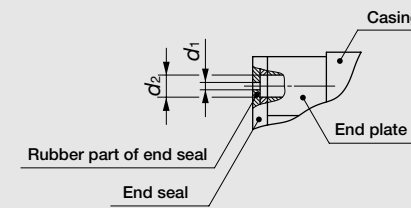

Series	Size	Oil hole size	
		d <sub>1</sub>	d <sub>2</sub>
C-Lube Linear Way ML	5 10	0.5	1.1
	7 14		1.2
	9 18		1.5
	12 24		2
C-Lube Linear Way MUL	25	0.5	1.2
	30		1.5
Linear Way L Ball Retained type	5 10	0.5	1.1
	7 14		1.2
	9 18		1.5
	12 24		2
Linear Way H	8 10	0.5	1.5
Linear Way U	25	0.5	1.2
	30		1.5

## Miniature greaser

The miniature greaser is specially prepared for grease replenishment for Linear Way with an oil hole shown in Table 8. Table 9 shows the types of grease and specifications of the miniature greaser.



Table 9 Specifications

Identification number	Grease name	Content	Outside diameter of injector needle
MG10/MT2	MULTEMP PS No.2 (KYODO YUSHI)	10ml	φ 1mm
MG10/CG2	<b>IKO</b> Low Dust Generation Grease for Clean Environment CG2		
MG2.5/EP2 <sup>(1)</sup>	Alvania EP Grease 2 [Shell]	2.5ml	
MG2.5/CG2	<b>IKO</b> Low Dust Generation Grease for Clean Environment CG2		
MG2.5/CGL	<b>IKO</b> Low Dust Generation Grease for Clean Environment CGL		
MG2.5/AF2	<b>IKO</b> Anti-Fretting Corrosion Grease AF2		

Note<sup>(1)</sup> : Applicable to size 10 of LRX.

## ● Grease nipple and supply nozzle

Tables 10.1 and 10.2 show the specifications of grease nipples and applicable types of supply nozzles. Table 11 shows the specifications of supply nozzles.



Grease nipple		Applicable supply nozzle	
Type	Shape and dimension	Type	Shape
A-M3		A-5120V A-5240V B-5120V B-5240V	Straight type 
A-M4			
B-M4		A-8120V B-8120V	Straight type with angle 

Table 10.2 Grease nipples and applicable supply nozzles

Grease nipple		Applicable supply nozzle	
Type	Shape and dimension	Type	Shape
B-M6		Product available on the market	Straight type 
JIS 1 type			Chuck type 
JIS 2 type			Hose type 
JIS 4 type			
JIS A-PT1/4			

Note(1): For straight type, chuck type and hose type supply nozzles available on the market, it is recommended to use one with an outside diameter (D) of 13 mm or less.

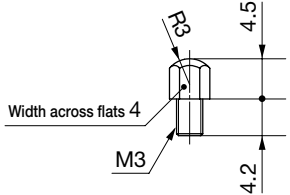
Table 11 Applicable supply nozzles

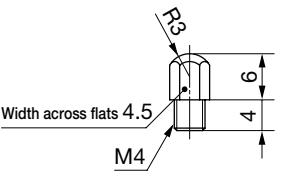
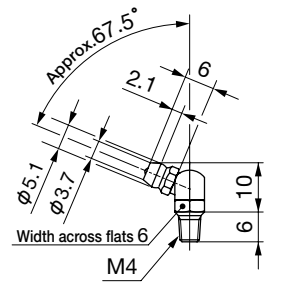
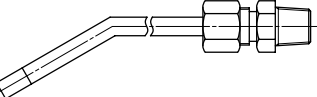
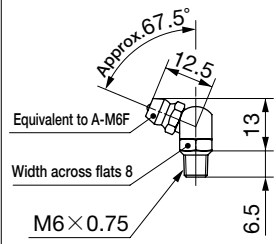
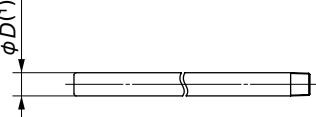
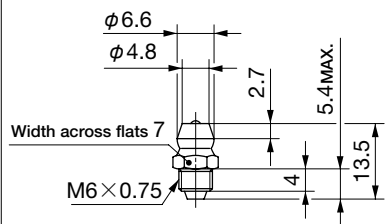
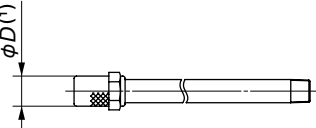
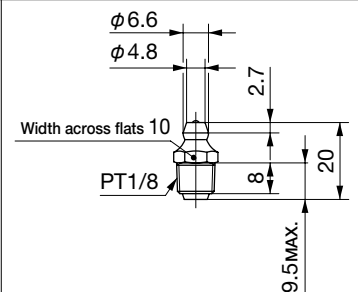
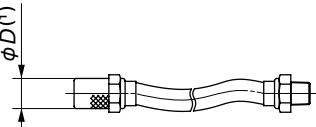
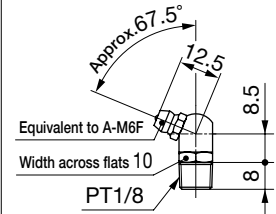
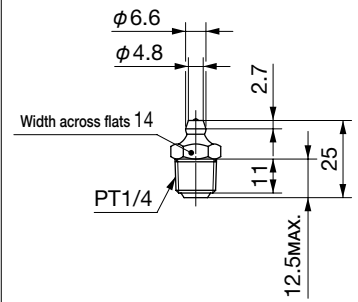
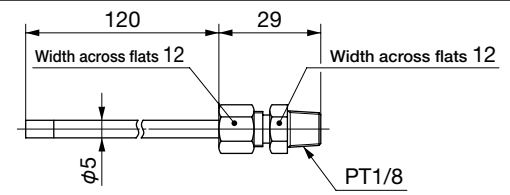
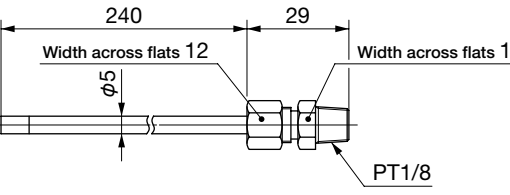
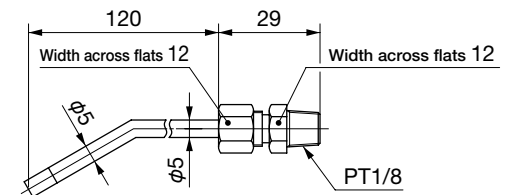
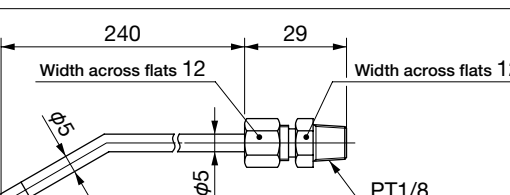
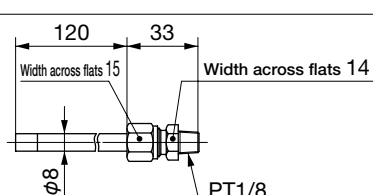
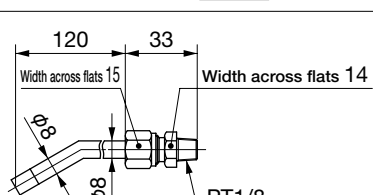
Type	Shape and dimension
A-5120V	
A-5240V	
B-5120V	
B-5240V	
A-8120V	
B-8120V	

Remark : The supply nozzles shown in the table can be mounted on the main body of a common grease gun available on the market (shown below). If these supply nozzles are required, consult **IKO** by specifying the supply nozzle type.

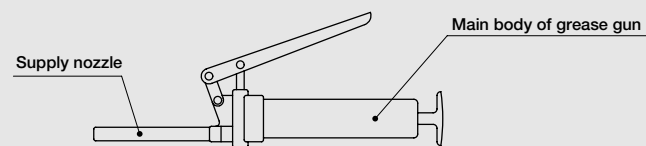

## Pipe joints

When applying centralized grease or oil lubrication, detach the grease nipple or stop cock from the slide unit, and replace them with pipe joints, which are prepared for various piping female thread sizes. Use them after comparing the dimension of the pipe joints and the dimension  $H_3$  in the dimension table of each series, because the top face of some pipe joints is at the same or higher level with the top face of slide unit. Fig. 4.1 and 4.2, Tables 12.1, 12.2, 13.1 and 13.2 show model numbers and dimensions of pipe joints. Note that some of them are not applicable for the slide units of special specifications. Pipe joints can be mounted on Linear Way and Linear Roller Way prior to delivery upon request. Consult **IKO** for further information.

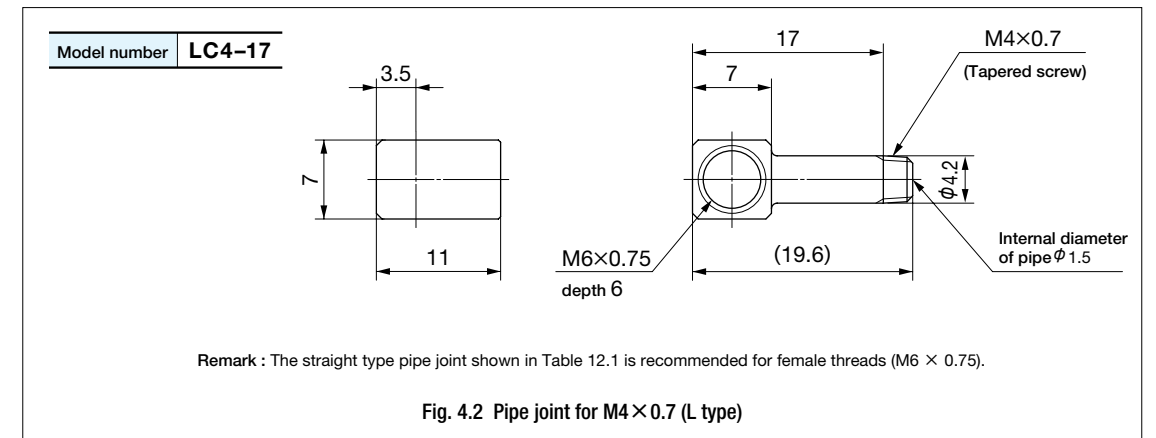
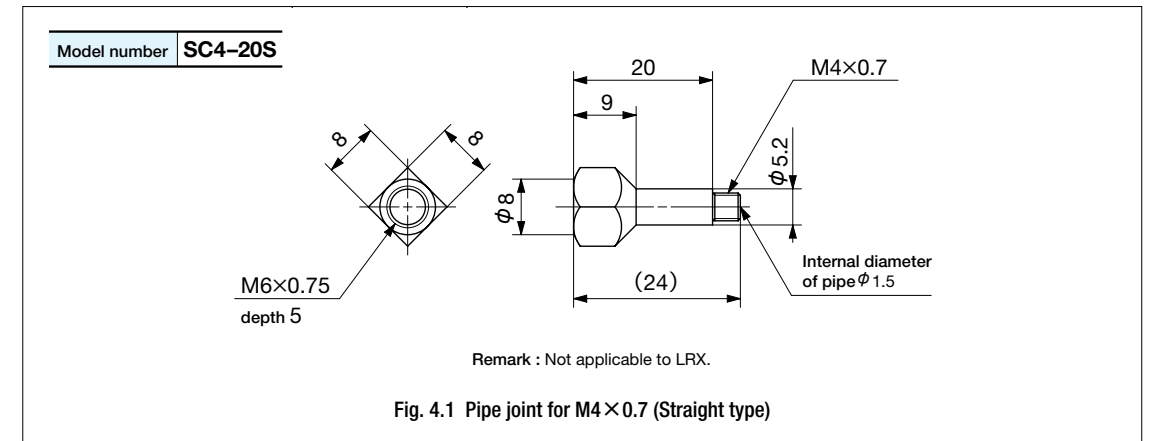

Table 12.1 Pipe joint for M6 × 0.75 (Straight type)

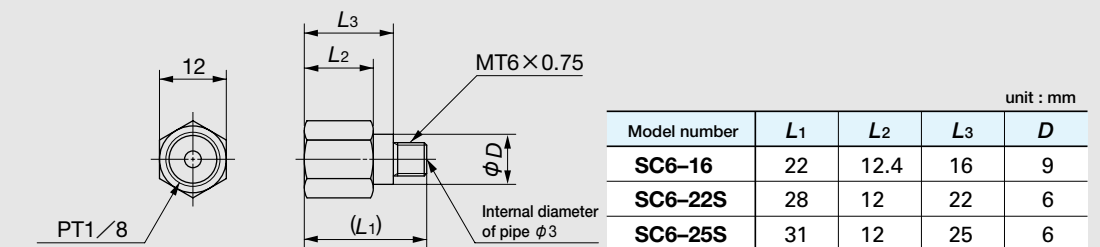



Table 12.2 Pipe joint for M6 × 0.75 (L type)

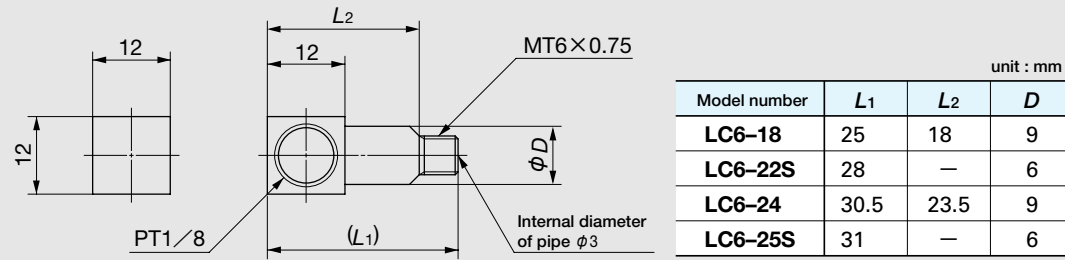

Table 13.1 Pipe joint for PT1/8 (Straight type)

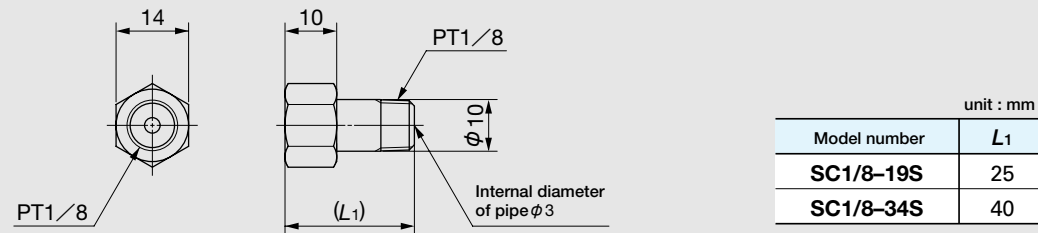
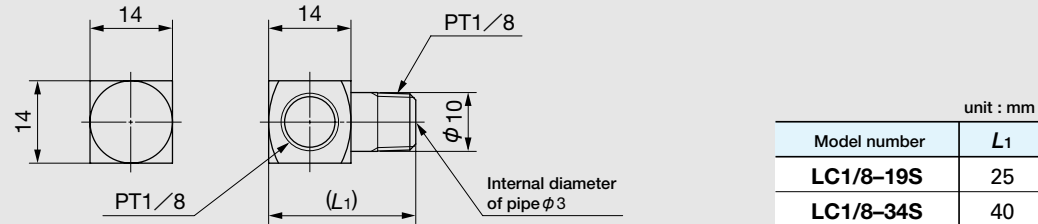

Table 13.2 Pipe joint for PT1/8 (L type)



## Bellows

Dimensions of bellows specially prepared for **IKO** Linear Way and Linear Roller Way are shown in Tables 15.1 and 15.2. These bellows are manufactured to match the dimensions of each series for easy mounting and effective dust protection.

For special bellows to be used in an upside-down position or those made of heat-resistant material, consult **IKO** for further information.

## Identification number of bellows

The identification number of bellows consists of a model code, dimensions, and any supplemental codes. Its standard arrangement is shown below.

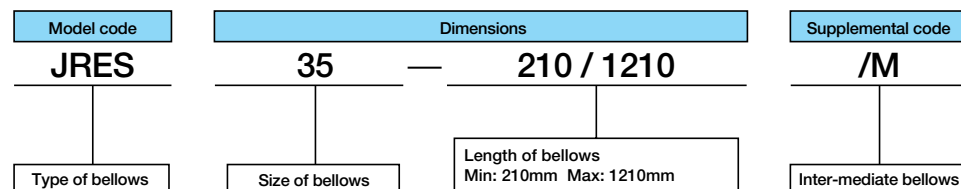

## Calculation of minimum length of bellows

The minimum necessary length of bellows is determined, by first calculating the necessary number of accordion pleats as follows.

$$ns = \frac{S}{\ell_{Smax} - \ell_{Smin}}$$

where,  $ns$ : Number of pleats (Raise decimal fractions.)

$S$ : Length of stroke, mm

$\ell_{Smax}$ : Maximum length of one pleat (See Tables 15.1 and 15.2.)

$\ell_{Smin}$ : Minimum length of one pleat (See Tables 15.1 and 15.2.)

$$L_{min} = ns \times \ell_{Smin} + m \times 5 + 10$$

$$L_{max} = S + L_{min}$$

where,  $L_{min}$ : Minimum length of bellows, mm

$L_{max}$ : Maximum length of bellows, mm

$m$ : Number of internal guide plates (See Table 14.)

Table 14 Number of internal guide plates

Type of bellows	Dimension $P$ of bellows (1) mm		Number of internal guide plates, $m$
	over	incl.	
JEF JRES	—	35	$m = \frac{ns}{7} - 1$
JES JHS JFS JFFS	—	22	$m = \frac{ns}{16}$ but $m=0$ , when $ns \leq 20$
	22	25	$m = \frac{ns}{12}$ but $m=0$ , when $ns \leq 18$
	25	35	$m = \frac{ns}{8}$

Note(1): For dimension  $P$ , see Tables 15.1 and 15.2.

Remark: In calculating the number of internal guide plates  $m$ , raise the decimal fractions for JEF and JRES and omit the decimal fractions for others.

## Intermediate bellows

Another type of mounting plate is used for mounting bellows between slide units. Add the supplemental code "/M" onto the identification number when ordering.

Reinforced bellows are also available, which are specially designed for use on long track rails or for lateral mounting. The width  $A$  of reinforced bellows is greater than that of standard type bellows. For these reinforced bellows, consult **IKO**.

Table 15.1 Dimensions of bellows and applicable models

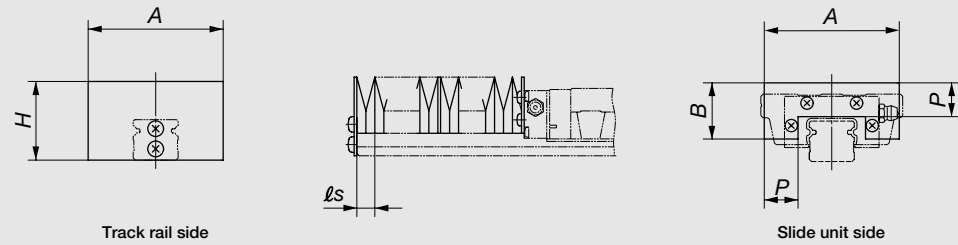

Type I

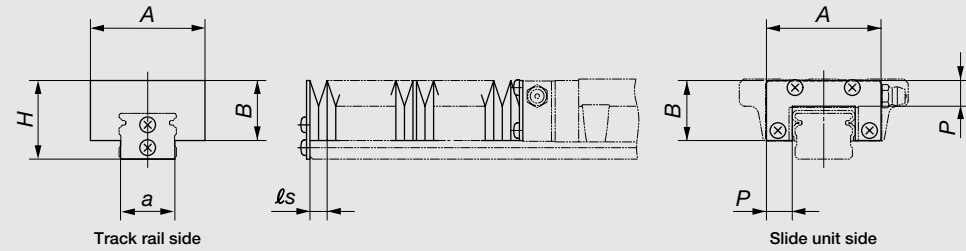

Type II

unit : mm										
Series	Size	Bellows model code	Type	H	A	a	B	P	lsmin	lsmax
C-Lube Linear Way ME	15	JEF15	II	23.5	34	14	17	8	2	9
	20	JEF20		27.5	40	19	21	9	2	10
	25	JEF25		32	46	22	24	10	2	11
	30	JES30		42	70	27	35	15	2	14
	35	JES35		48	85	33	40	18	2	18.5
C-Lube Linear Way MH	15	JHS15	I	31 <sup>(2)</sup>	55	-	19.5	15	2	14
	20	JHS20		35 <sup>(2)</sup>	60	-	25	15	2	14
	25	JHS25		39 <sup>(2)</sup>	64	-	29.5	15	2	14
	30	JHS30		42	70	-	35	15	2	14
	35	JHS35		48	85	-	40	18	2	18.5
Linear Way E	15	JEF15	II	23.5	34	14	17	8	2	9
	20	JEF20		27.5	40	19	21	9	2	10
	25	JEF25		32	46	22	24	10	2	11
	30	JES30		42	70	27	35	15	2	14
	35	JES35		48	85	33	40	18	2	18.5
	45	JES45	60	105	44	50	22	2	23.5	

Note<sup>(1)</sup> : Not applicable for LWHY series.

<sup>(2)</sup> : The height of bellows may become higher than the height *H* of Linear Way. Check *H* dimension of Linear Way shown in the table of dimensions of each series.

<sup>(3)</sup> : The width of bellows may become larger than the width *W*<sub>2</sub> of Linear Way. Check *W*<sub>2</sub> dimension of Linear Way shown in the table of dimensions of each series.

Table 15.2 Dimensions of bellows and applicable models

unit : mm

Series	Size	Bellows model code	Type	H	A	a	B	P	lsmin	lsmax
Linear Way H <sup>(1)</sup>	15	JHS15	I	31 <sup>(2)</sup>	55	-	19.5	15	2	14
	20	JHS20		35 <sup>(2)</sup>	60	-	25	15	2	14
	25	JHS25		39 <sup>(2)</sup>	64	-	29.5	15	2	14
	30	JHS30		42	70	-	35	15	2	14
	35	JHS35		48	85	-	40	18	2	18.5
	45	JHS45		60	105	-	50	22	2	23.5
	55	JHS55		70	120	-	57	25	2	28
	65	JHS65	90	158	-	76	35	2	42	
Linear Way F	33	JFFS33	II	26 <sup>(2)</sup>	66 <sup>(3)</sup>	-	23	15	2	15
	37	JFFS37	II	27.5 <sup>(2)</sup>	70 <sup>(3)</sup>	-	24	15	2	15
	40	JFS40	I	32 <sup>(2)</sup>	80	-	27	15	2	14
	42	JFFS42	II	30.5 <sup>(2)</sup>	76 <sup>(3)</sup>	-	27.5	15	2	15
	60	JFS60	I	36 <sup>(2)</sup>	100	-	30	15	2	14
	69	JFFS69	II	36 <sup>(2)</sup>	106	-	31.5	15	2	15
	90	JFS90	I	50	150	-	43	22	2	23.5

Note<sup>(1)</sup> : Not applicable for LWHY series.

<sup>(2)</sup> : The height of bellows may become higher than the height *H* of Linear Way. Check *H* dimension of Linear Way shown in the table of dimensions of each series.

<sup>(3)</sup> : The width of bellows may become larger than the width *W*<sub>2</sub> of Linear Way. Check *W*<sub>2</sub> dimension of Linear Way shown in the table of dimensions of each series.

Table 15.3 Dimensions of bellows and applicable models

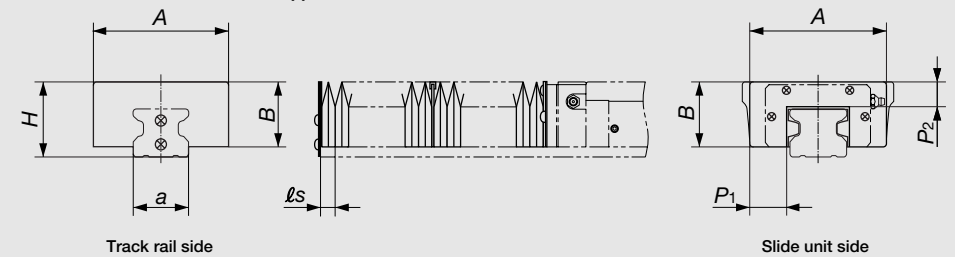

unit : mm											
Series	Size	Bellows model code	H	A	a	B	P <sub>1</sub>	P <sub>2</sub>	lsmin	lsmax	
C-Lube Linear Roller Way Super MX	15	JRES 15	34 <sup>(1)</sup>	55 <sup>(2)</sup>	14	30	17.5	15	2	15	
	20	JRES 20	39 <sup>(1)</sup>	60 <sup>(2)</sup>	19	34	15	15	2	15	
	25	JRES 25	42 <sup>(1)</sup>	65 <sup>(2)</sup>	22	36	16.5	15	2	15	
	30	JRES 30	46 <sup>(1)</sup>	70 <sup>(2)</sup>	27	39.5	15	15	2	15	
	35	JRES 35	48	88 <sup>(2)</sup>	33	41.5	24	15	2	15	
	45	JRES 45	60	108 <sup>(2)</sup>	44	52	29	20	2	21	
	55	JRES 55	70	122 <sup>(2)</sup>	52	61	31	22	2	23.5	
	65	JRES 65	88	140 <sup>(2)</sup>	61	76	25	25	2	30	
	Linear Roller Way Super X	15	JRES 15	34 <sup>(1)</sup>	55 <sup>(2)</sup>	14	30	17.5	15	2	15
		20	JRES 20	39 <sup>(1)</sup>	60 <sup>(2)</sup>	19	34	15	15	2	15
25		JRES 25	42 <sup>(1)</sup>	65 <sup>(2)</sup>	22	36	16.5	15	2	15	
30		JRES 30	46 <sup>(1)</sup>	70 <sup>(2)</sup>	27	39.5	15	15	2	15	
35		JRES 35	48	88 <sup>(2)</sup>	33	41.5	24	15	2	15	
45		JRES 45	60	108 <sup>(2)</sup>	44	52	29	20	2	21	
55		JRES 55	70	122 <sup>(2)</sup>	52	61	31	22	2	23.5	
65		JRES 65	88	140 <sup>(2)</sup>	61	76	25	25	2	30	
85		JRES 85	107	180	82	89	30	30	2	36	
100		JRES100	115	214	96	100	35	35	2	45	

Note<sup>(1)</sup> : The height of bellows may become higher than the height *H* of Linear Roller Way. Check *H* dimension of Linear Roller Way shown in the table of dimensions of each series.

<sup>(2)</sup> : The height of bellows may become higher than the height *H* of Linear Way. Check *H* dimension of Linear Roller Way shown in the table of dimensions of each series.

## Precautions for Use

### ● Mounting structure

#### Mounting surface, reference mounting surface, and general mounting structure

To mount Linear Way or Linear Roller Way, correctly fit the reference mounting surfaces B and D of the slide unit and the track rail to the reference mounting surfaces of the table and the bed, and then fix them tightly. (See Figs. 5 and 6.)

The reference mounting surfaces B and D and mounting surfaces A and C of Linear Way or Linear Roller Way are accurately finished by grinding. Stable and high accuracy linear motion can be obtained by finishing the mating mounting surfaces of machines or equipment with high accuracy and correctly mounting the guide on these surfaces.

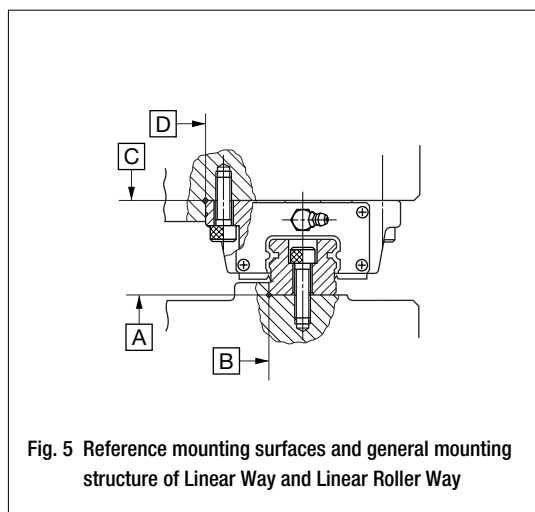

Fig. 5 Reference mounting surfaces and general mounting structure of Linear Way and Linear Roller Way

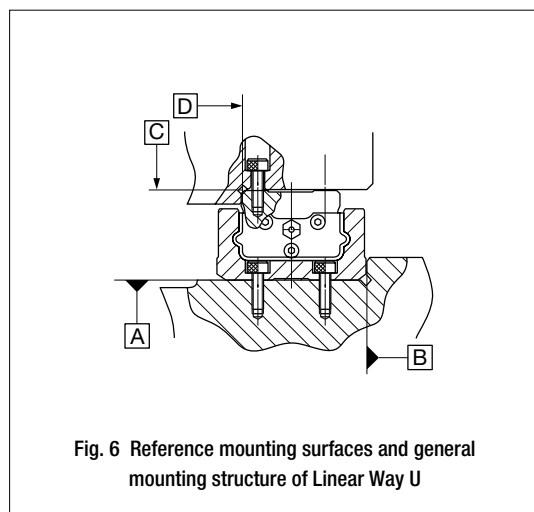

Fig. 6 Reference mounting surfaces and general mounting structure of Linear Way U

The slide unit reference mounting surface is always the side surface opposite to the **IKO** mark. The track rail reference mounting surface is identified by locating the **IKO** mark on the top surface of the track rail. The track rail reference mounting surface is the side surface above the **IKO** mark (in the direction of the arrow). (See Figs. 7 and 8.)

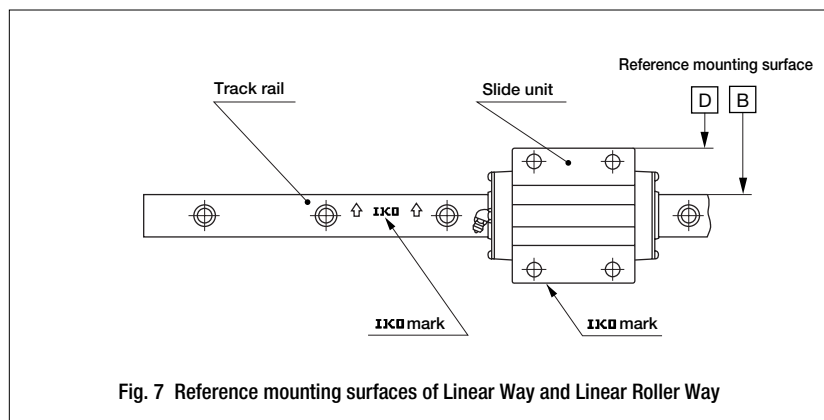

Fig. 7 Reference mounting surfaces of Linear Way and Linear Roller Way

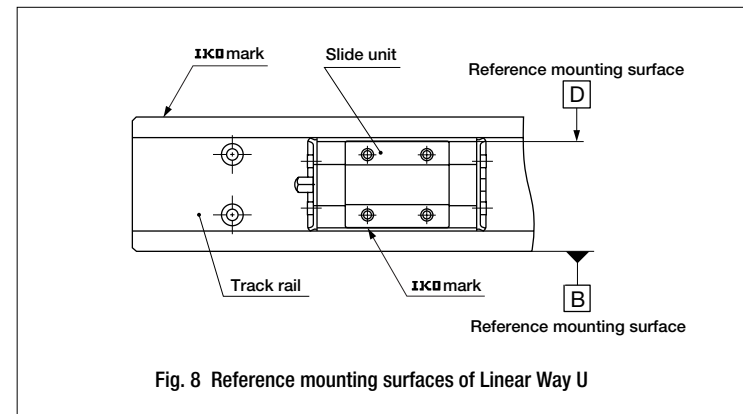

Fig. 8 Reference mounting surfaces of Linear Way U

#### Load direction and mounting structure

When a lateral load, alternate load, or fluctuating load is applied to Linear Way or Linear Roller Way, firmly fix the side faces of the slide unit and track rail as shown in Fig. 9 and Fig. 10.

When the applied load is small or the operating conditions are not too severe, mounting methods shown in Fig. 11 and Fig. 12 are also used.

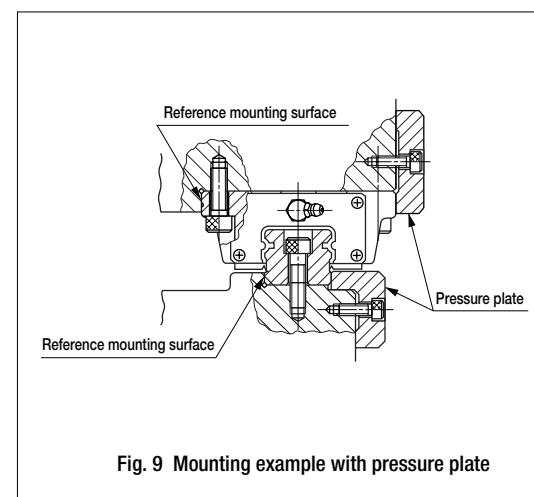

Fig. 9 Mounting example with pressure plate

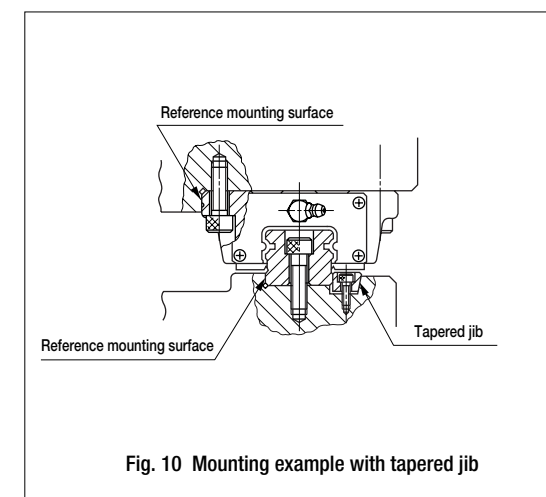

Fig. 10 Mounting example with tapered jib

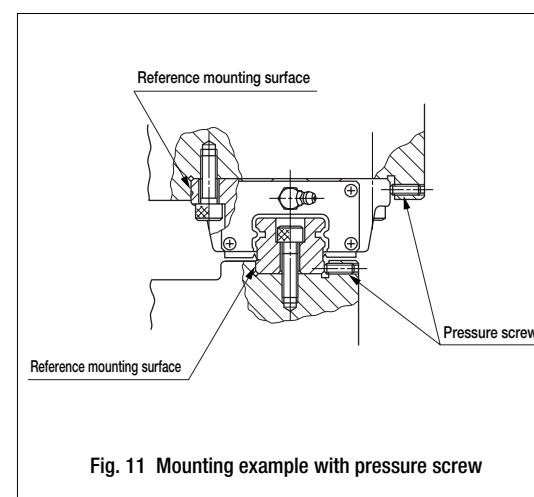

Fig. 11 Mounting example with pressure screw

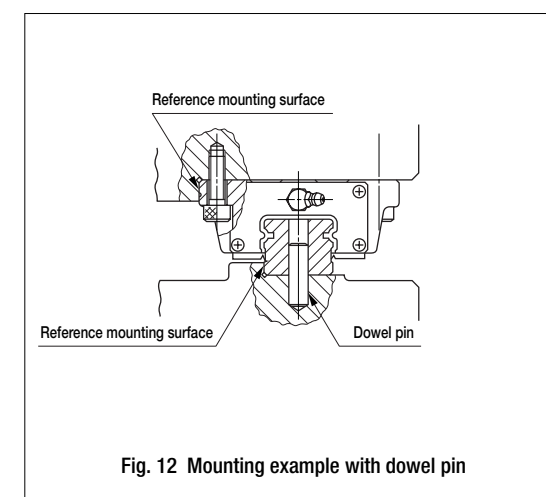

Fig. 12 Mounting example with dowel pin

## Mounting of Linear Way L (For the size 2, 3, 4 and 6)

The general mounting structure of Linear Way L is similar to that shown in Fig. 5. The slide unit of this series is mounted by tightening bolts in the female threads of the slide unit.

For the size 2, 3, 4 and 6 models, the female threads for mounting the slide unit and the track rail are through holes. (See Fig. 13.) If the fixing depth of the mounting bolts is too long, the bolts will interfere with the slide unit or track rail, resulting in poor traveling accuracy and short life. The fixing depth of the mounting bolts should be kept within the values shown in the table of dimensions.

The mounting bolts for the track rail are not appended to the tapped rail specification products. Prepare bolts with a fixing depth not exceeding  $H_4$  shown in the dimension table.

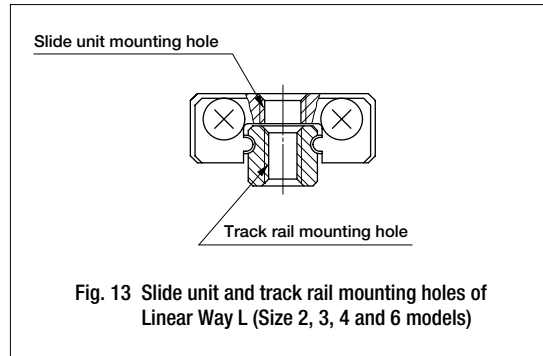

Fig. 13 Slide unit and track rail mounting holes of Linear Way L (Size 2, 3, 4 and 6 models)

## Mounting of C-Lube Linear Roller Way Super MX and Linear Roller Way Super X

The general mounting structure of C-Lube Linear Roller Way Super MX and Linear Roller Way Super X is similar to that shown in Fig. 5. Some slide units are provided with one or two mounting thread holes in the middle of width (See Fig. 14.) so that an applied load can be received with good load balance. When designing machines or equipment, ensure that these middle mounting holes of the slide unit can be securely tightened to obtain maximum performance of the guide.

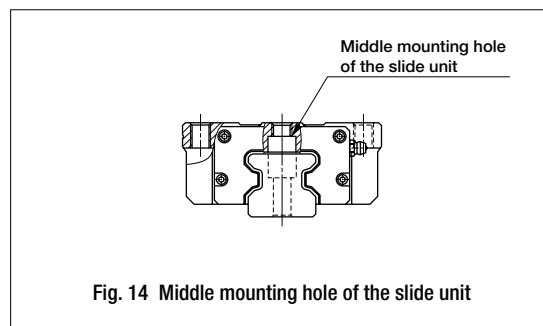

Fig. 14 Middle mounting hole of the slide unit

## Mounting of Linear Way Module

Fig. 15 shows the standard mounting structure of Linear Way Module. As a convenient means to eliminate play or give preload, preload adjusting screws are often used in linear motion rolling guides.

Set the preload adjusting screws at the positions of fixing bolts of slide member and in the middle of the height of slide member, and then press the slide member by tightening the screw.

For mounting the slide member of Linear Way Module LM, it is recommended to fix the slide member from the table side, because the allowance for preload adjustment in the bolt hole of slide member is small. In this case, the bolt hole and the counter bore in the table should be made larger to give the adjustment allowance.

The preload amount differs depending on the operating conditions of machines or equipment. An excessive preload will result in short bearing life and raceway damage. The preload amount for general application should be adjusted to a zero or slight minus clearance in the ideal case.

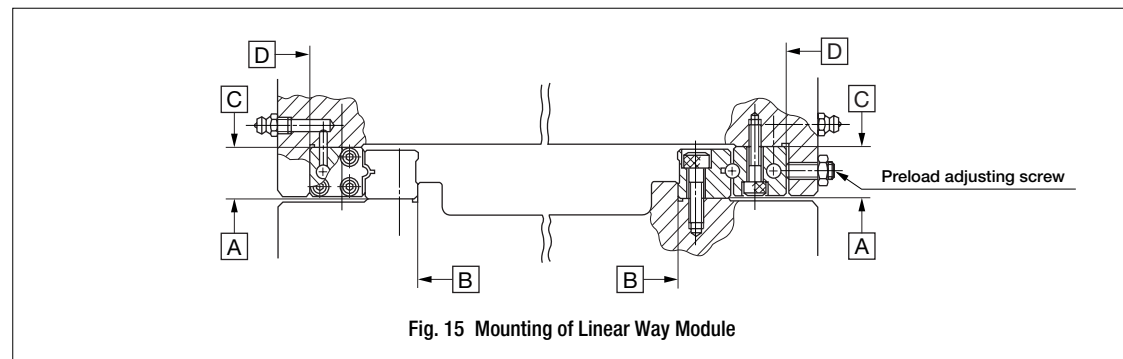

Fig. 15 Mounting of Linear Way Module

## Specifications of mounting parts

### Accuracy of mounting surfaces

The life and other performances of Linear Way and Linear Roller Way are greatly affected by the accuracy of the mounting surfaces of machines and equipment and the mounting accuracy. Poor accuracy may result in producing a larger load than the calculated load, and eventually lead to short life, etc.

Reliable operation of linear motion rolling guide is ensured by providing high manufacturing and mounting accuracy of mounting parts and designing a mounting structure so as to keep the accuracy and performance, while considering the required linear motion accuracy, rigidity and other related operating conditions.

As an example, the standard values of parallelism between two track rail mounting surfaces when multiple sets are used, are shown in Table 30 on page 126.

### Corner radius and shoulder height of reference mounting surfaces

It is recommended to make a relieved fillet at the corner of the mating reference mounting surfaces as shown in Fig. 16. However, in some series, corner radii  $R_1$  and  $R_2$  shown in Fig. 17 can also be used. Tables 16.1 to 27.3 show recommended shoulder heights and corner radii of the mating reference mounting surfaces.

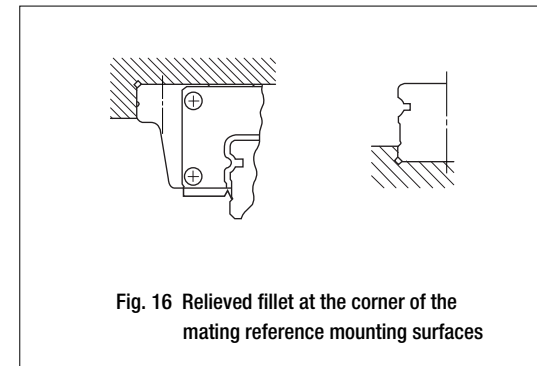

Fig. 16 Relieved fillet at the corner of the mating reference mounting surfaces

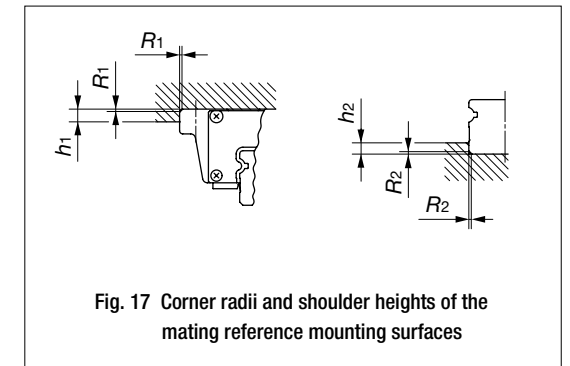

Fig. 17 Corner radii and shoulder heights of the mating reference mounting surfaces

Table 16.1 Shoulder heights and corner of the mating reference mounting of C-Lube Linear Way ML standard type

Model number	Slide unit		Track rail	
	Shoulder height $h_1$	Corner radius $R_1$ (max.)	Shoulder height <sup>(1)</sup> $h_2$	Corner radius $R_2$ (max.)
ML 5	2	0.3	0.8	0.2
ML 7	2.5	0.2	1.2	0.2
ML 9	3	0.2	1.5	0.2
ML 12	4	0.2	2.5	0.2
ML 15	4.5	0.2	3	0.2
ML 20	5	0.2	4	0.2
ML 25	6.5	0.7	4	0.7

unit : mm

Note<sup>(1)</sup> : For models with under seals (U), it is use  $h_2$  values 1mm smaller than the values in the table.

However, for "with under seals" of the size 9 models, 0.8mm is recommended.

Remark : The above table shows representative model numbers but is applicable to all models.

Table 16.2 Shoulder heights and corner of the mating reference mounting of C-Lube Linear Way ML wide rail type

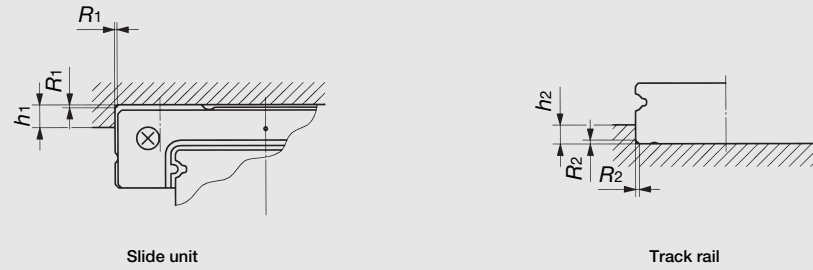

Model number	Slide unit		Track rail	
	Shoulder height $h_1$	Comer radius $R_1$ (max.)	Shoulder height <sup>(1)</sup> $h_2$	Comer radius $R_2$ (max.)
<b>MLF 10</b>	2	0.3	1.2	0.2
<b>MLF 14</b>	2.5	0.2	1.2	0.2
<b>MLF 18</b>	3	0.2	2.5	0.2
<b>MLF 24</b>	4	0.2	2.5	0.2
<b>MLF 30</b>	4.5	0.2	2.5	0.2
<b>MLF 42</b>	5	0.2	3	0.2

Note<sup>(1)</sup> : For models with under seals (U), it is use  $h_2$  values 1mm smaller than the values in the table.  
 Remark : The above table shows representative model numbers but is applicable to all models.

Table 17 Shoulder heights and corner of the mating reference mounting of C-Lube Linear Way ME

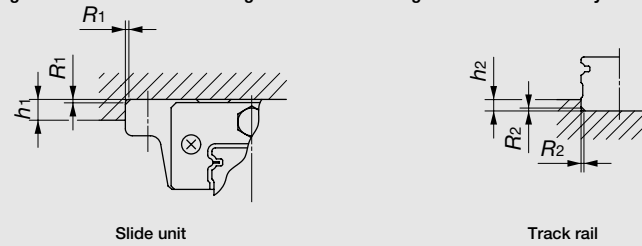

Model number	Slide unit		Track rail	
	Shoulder height $h_1$	Comer radius $R_1$ (max.)	Shoulder height $h_2$	Comer radius $R_2$ (max.)
<b>ME(T) 15</b>	4	1	3	0.5
<b>MES 15</b>		0.5		
<b>ME(T) 20</b>	5	1	3	0.5
<b>MES 20</b>		0.5		
<b>ME(T) 25</b>	6	1	4	1
<b>MES 25</b>				
<b>ME(T) 30</b>	8	1	5	1
<b>MES 30</b>				
<b>ME(T) 35</b>	8	1	6	1
<b>MES 35</b>				
<b>ME(T) 45</b>	8	1.5	7	1.5
<b>MES 45</b>				

Remark : The above table shows representative model numbers but is applicable to all models.

Table 18 Shoulder heights and corner of the mating reference mounting of C-Lube Linear Way MH

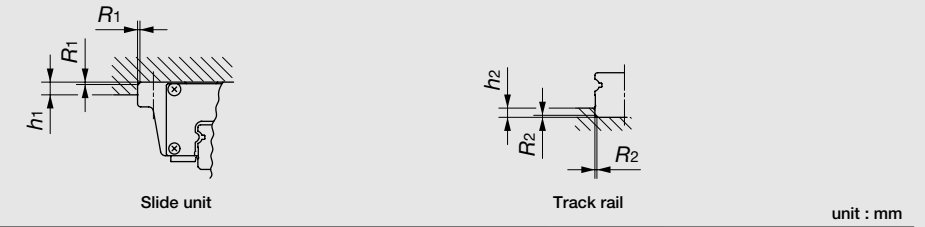

Model number	Slide unit		Track rail	
	Shoulder height $h_1$	Comer radius $R_1$ (max.)	Shoulder height $h_2$	Comer radius $R_2$ (max.)
<b>MHT 8···SL</b>	3.5	0.5	1.6 <sup>(1)</sup>	0.2
<b>MHD 8···SL</b>	4	0.5	1.6 <sup>(1)</sup>	0.2
<b>MHT 10···SL</b>	4.5	0.5	1.9 <sup>(1)</sup>	0.2
<b>MHD 10···SL</b>	5	0.5	1.9 <sup>(1)</sup>	0.2
<b>MHT 12</b>	6	0.5	2.7 <sup>(1)</sup>	0.7
<b>MHD 12</b>	6	0.5	2.7 <sup>(1)</sup>	0.7
<b>MH 15</b>	4	0.5	3	0.5
<b>MH 20</b>	5	0.5	3	0.5
<b>MH 25</b>	6	1	4	1
<b>MH 30</b>	8	1	5	1
<b>MH 35</b>	8	1	6	1
<b>MH 45</b>	8	1.5	7	1.5

Note<sup>(1)</sup> : For models with under seals (U), it is recommended to use  $h_2$  values 0.6mm smaller than the values in the table.  
 Remark : The above table shows representative model numbers but is applicable to all models.

Table 19 Shoulder heights and corner of the mating reference mounting of C-Lube Linear Way MUL

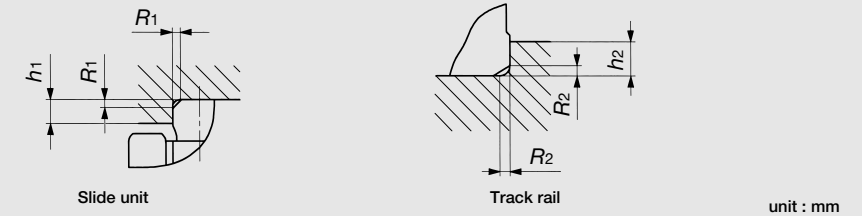

Model number	Slide unit		Track rail	
	Shoulder height $h_1$	Comer radius $R_1$ (max.)	Shoulder height $h_2$	Comer radius $R_2$ (max.) <sup>(1)</sup>
<b>MUL 25</b>	1.5	0.2	2.5	—
<b>MUL 30</b>	2.5	0.2	3	—

Note<sup>(1)</sup> : Please provide a relieved fillet as shown on Fig.16.

Table 20 Shoulder height and radius of the reference mounting of C-Lube Linear Roller Way Super MX

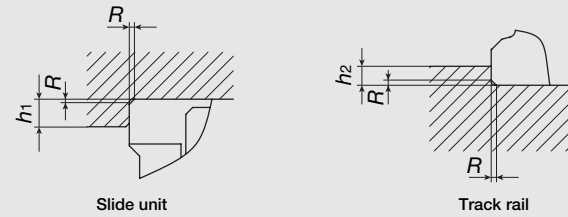

Model number	Slide unit Shoulder height $h_1$	Track rail Shoulder height $h_2$	Relieved radius $R$ (max.)
<b>MX 15</b>	4	3	0.5
<b>MX 20</b>	5	4	0.5
<b>MX 25</b>	6	5	1
<b>MX 30</b>	8	5.5	1
<b>MX 35</b>	8	5.5	1
<b>MX 45</b>	8	7	1.5
<b>MX 55</b>	10	8	1.5
<b>MX 65</b>	10	10	1.5

Remark : The table shows representative model numbers but is applicable to all models of the same size.

Table 21.1 Shoulder heights and corner radii of the mating reference mounting surfaces of Linear Way L standard type

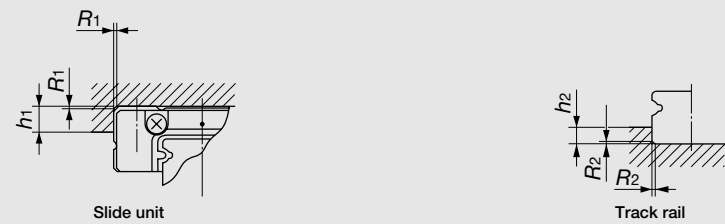

Model number	Slide unit		Track rail	
	Shoulder height $h_1$	Corner radius $R_1$ (max.)	Shoulder height <sup>(1)</sup> $h_2$	Corner radius $R_2$ (max.)
<b>LWL 1</b>	1.3	—	—	—
<b>LWL 1...Y</b>			2	—
<b>LWL 2</b>	1	0.1	0.5	0.05
<b>LWL 3</b>	1.2	0.15	0.8	0.1
<b>LWL 5...B</b>	2	0.3	0.8	0.2
<b>LWL 5</b>			0.8	
<b>LWL 7...B</b>	2.5	0.2	1.2	0.2
<b>LWL 7</b>			1.2	
<b>LWL 9...B</b>	3	0.2	1.5	0.2
<b>LWL 9...BCS</b>		0.4		
<b>LWL 9</b>		0.2		
<b>LWL 12...B</b>	4	0.2	2.5	0.2
<b>LWL 12...BCS</b>		0.4		
<b>LWL 12</b>		0.2		
<b>LWL 12...CS</b>		0.4		
<b>LWL 15...B</b>	4.5	0.2	3	0.2
<b>LWL 15...BCS</b>		0.4		
<b>LWL 15</b>	4	0.2	4	0.2
<b>LWL 15...CS</b>		0.4		
<b>LWL 20...B</b>	5	0.2	4	0.2
<b>LWL 20...BCS</b>		0.4		
<b>LWL 25...B</b>	6.5	0.7	4	0.7

Note<sup>(1)</sup> : For models with under seals (U), it is recommended to use  $h_2$  values 1mm smaller than the values in the table. However, for "with under seals" of the size 9 models, 0.8mm is recommended.

Remark : The above table shows representative model numbers but is applicable to all models.

Table 21.2 Shoulder heights and corner radii of the mating reference mounting surfaces of Linear Way L wide rail type

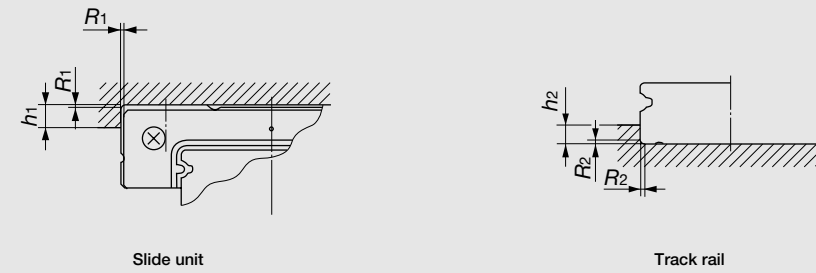

Model number	Slide unit		Track rail	
	Shoulder height $h_1$	Corner radius $R_1$ (max.)	Shoulder height <sup>(1)</sup> $h_2$	Corner radius $R_2$ (max.)
<b>LWLF 4</b>	1.5	0.1	0.8	0.1
<b>LWLF 6</b>	2	0.1	0.8	0.1
<b>LWLF 10...B</b>	2	0.3	1.2	0.2
<b>LWLF 14...B</b>	2.5	0.2	1.2	0.2
<b>LWLF 14</b>		0.2		
<b>LWLF 18...B</b>	3	0.2	2.5	0.2
<b>LWLF 18...BCS</b>		0.4		
<b>LWLF 18</b>		0.2		
<b>LWLF 18...CS</b>	4	0.4	1.5	0.2
<b>LWLF 24...B</b>		0.2		
<b>LWLF 24...BCS</b>	3	0.4	2.5	0.2
<b>LWLF 24</b>		0.2		
<b>LWLF 24...CS</b>	4.5	0.4	2.5	0.2
<b>LWLF 30...B</b>		0.2		
<b>LWLF 30...BCS</b>	5	0.4	3	0.2
<b>LWLF 42...B</b>		0.2		
<b>LWLF 42...BCS</b>	4	0.4	2.5	0.2
<b>LWLF 42</b>		0.2		
<b>LWLF 42...CS</b>	0.4	0.4	2.5	0.2

Note<sup>(1)</sup> : For models with under seals (U), it is recommended to use  $h_2$  values 1mm smaller than the values in the table. Remark : The above table shows representative model numbers but is applicable to models.

Table 22 Shoulder heights and corner radii of the mating reference mounting surfaces of Linear Way E

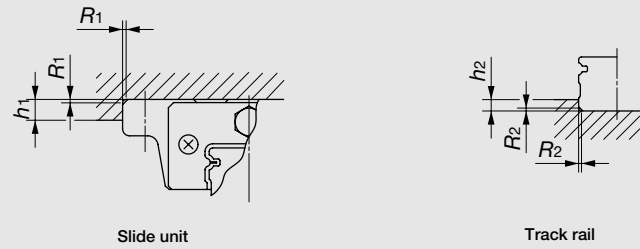

unit : mm

Model number	Slide unit		Track rail	
	Shoulder height $h_1$	Corner radius $R_1(\text{max.})$	Shoulder height $h_2$	Corner radius $R_2(\text{max.})$
<b>LWE(T) 15</b>	4	1	3	0.5
<b>LWES 15</b>		0.5		
<b>LWE(T) 20</b>	5	1	3	0.5
<b>LWES 20</b>		0.5		
<b>LWE(T) 25</b>	6	1	4	1
<b>LWES 25</b>		1		
<b>LWE(T) 30</b>	8	1	5	1
<b>LWES 30</b>		1		
<b>LWE(T) 35</b>	8	1	6	1
<b>LWES 35</b>		1		
<b>LWE(T) 45</b>	8	1.5	7	1.5
<b>LWES 45</b>		1.5		

Remark : The above table shows representative model numbers but is applicable to all models.

Table 23 Shoulder heights and corner radii of the mating reference mounting surfaces of Linear Way H

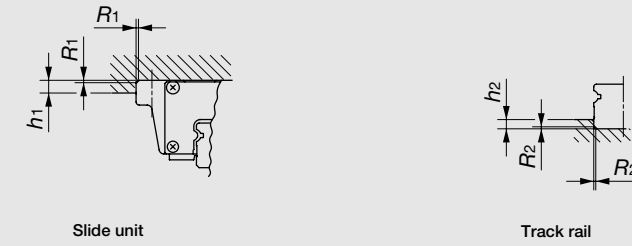

unit : mm

Model number	Slide unit		Track rail	
	Shoulder height $h_1$	Corner radius $R_1(\text{max.})$	Shoulder height $h_2$	Corner radius $R_2(\text{max.})$
<b>LWHT 8...SL</b>	3.5	0.5	1.6 <sup>(1)</sup>	0.2
<b>LWHD 8...SL</b>	4	0.5	1.6 <sup>(1)</sup>	0.2
<b>LWHT 10...SL</b>	4.5	0.5	1.9 <sup>(1)</sup>	0.2
<b>LWHD 10...SL</b>	5	0.5	1.9 <sup>(1)</sup>	0.2
<b>LWHT 12</b>	6	0.5	2.7 <sup>(1)</sup>	0.7
<b>LWHD 12</b>	6	0.5	2.7 <sup>(1)</sup>	0.7
<b>LWH 15...B</b>	4	0.5	3	0.5
<b>LWH 20...B</b>	5	0.5	3	0.5
<b>LWH 25...B</b>	6	1	4	1
<b>LWH 30...B</b>	8	1	5	1
<b>LWH 35...B</b>	8	1	6	1
<b>LWH 45...B</b>	8	1.5	7	1.5
<b>LWH 55...B</b>	10	1.5	8	1.5
<b>LWH 65...B</b>	10	1.5	10	1.5

Note<sup>(1)</sup> : For models with under seals (/U), it is recommended to use  $h_2$  values 0.6mm smaller than the values in the table.  
 Remark : The above table shows representative model numbers but is applicable to all models.

Table 24.1 Shoulder heights and corner radius of the mating reference mounting surfaces of Linear Way F

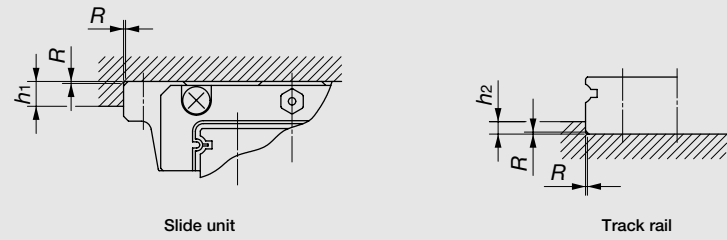

unit : mm

Model number	Slide unit Shoulder height $h_1$	Track rail Shoulder height $h_2$	Corner radius $R(\text{max.})$
<b>LWFF 33</b> <b>LWFS 33</b>	4	2	0.4
<b>LWFF 37</b> <b>LWFS 37</b>	5	2.5	0.4
<b>LWFF 42</b>	5	2.5	0.4
<b>LWFF 69</b>	5	3.5	0.8

Table 24.2 Shoulder heights and corner radii of the mating reference mounting surfaces of Linear Way F

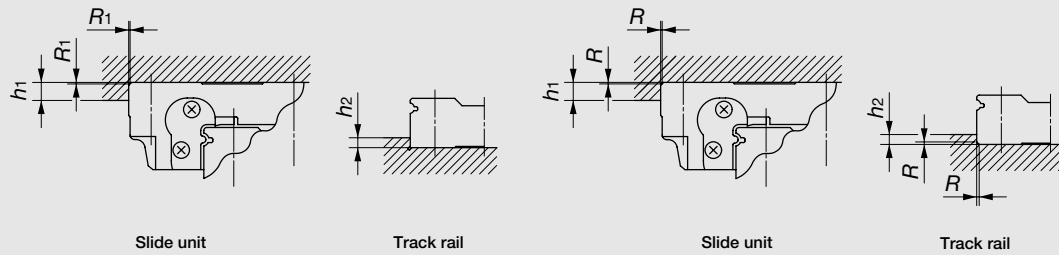

When supplemental code "/CC" is specified

unit : mm

Model number	Slide unit		Track rail Shoulder height $h_2$	Corner radius for "/>
	Shoulder height $h_1$	Corner radius $R_1(\text{max.})$		
<b>LWFH 40</b>	4	0.3	3	1
<b>LWFH 60</b>	6	0.5	4	1
<b>LWFH 90</b>	8	0.5	6	1

Table 25 Shoulder heights and corner radii of the mating reference mounting surfaces of Linear Way U

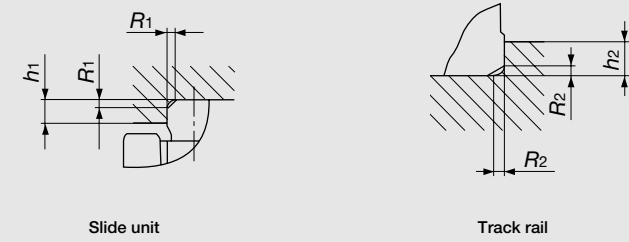

unit : mm

Model number	Slide unit		Track rail	
	Shoulder height $h_1$	Corner radius $R_1(\text{max.})$	Shoulder height $h_2$	Corner radius $R_2(\text{max.})$ (1)
<b>LWUL 25··B</b>	1.5	0.2	2.5	—
<b>LWUL 30··B</b>	2.5	0.2	3	—
<b>LWU 40··B</b>	3	0.5	5	1
<b>LWU 50··B</b>	3	0.5	7	2
<b>LWU 60··B</b>	3	0.5	9	2
<b>LWU 86··B</b>	4	0.5	11	2
<b>LWU 100</b>	4	0.5	13	1
<b>LWU 130</b>	5	1	14	2

Note(1) : For the size 25 and 30 models, provide a relieved fillet as shown on Fig. 16.



Table 26 Shoulder heights and corner radius of the mating reference mounting surfaces of Linear Roller Way Super X

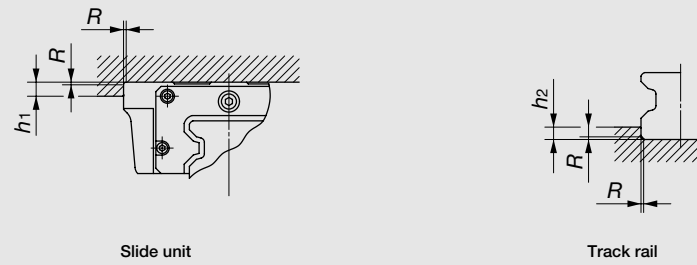

unit : mm

Model number	Slide unit Shoulder height $h_1$	Track rail Shoulder height $h_2$	Corner radius $R_{(max.)}$
LRXD 10...SL	4	1	0.3
LRX 12	4	2	0.5
LRX 15	4	3	0.5
LRX 20	5	4	0.5
LRX 25	6	5	1
LRX 30	8	5.5	1
LRX 35	8	5.5	1
LRX 45	8	7	1.5
LRX 55	10	8	1.5
LRX 65	10	10	1.5
LRX 85	14	14	2.5
LRX 100	14	13	2.5

Remark : The above table shows representative model numbers but is applicable to all models.

Table 27.1 Shoulder height of the mating reference mounting surface of Linear Way Module LM

unit : mm

Model number	$h$
LWLM 7	4
LWLM 9	5
LWLM 11	6

Table 27.2 Shoulder height and corner radius of the mating reference mounting surfaces of Linear Way Module M

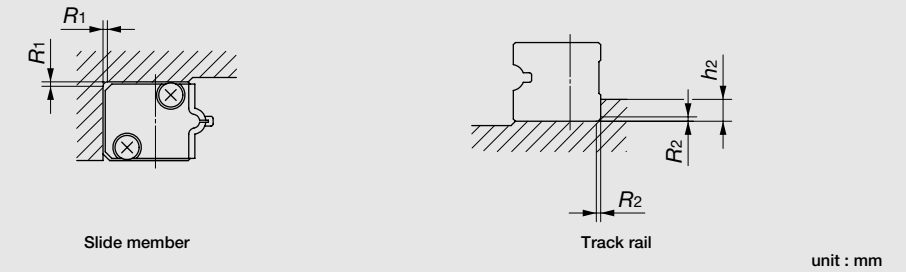

unit : mm

Model number	Slide member Corner radius $R_{1(max.)}$	Track rail	
		Shoulder height $h_2$	Corner radius $R_{2(max.)}$
LWM 1	0.8	4	0.8
LWM 2	1	5	1
LWM 3	1	5	1
LWM 4	1.5	6	1
LWM 5	1.5	6	1
LWM 6	1.5	8	1.5

## ● Operating conditions

### Multiple slide units mounted in close distance

When multiple slide units are used in close distance to each other, the actual load may be greater than the calculated load depending on the accuracy of the mounting surfaces and the reference mounting surfaces of the machine. It is suggested in such cases to assume a greater load than the calculated load.

### For lateral or upside-down mounting

When mounting Linear Way E or Linear Way F slide units in lateral or reverse (upside-down) position, specify slide units with under seals (supplemental code "/U"), if necessary, to prevent foreign particles from intruding into the slide units.

### Operating speed

The limiting values for operating speed of Linear Way or Linear Roller Way depend on various operating conditions such as the type of motion, magnitude of applied load, lubrication conditions, mounting accuracy, and ambient temperature.

Based on the experiences and actual practice, standard values of maximum speed under general operating conditions are given in Table 28 for reference.

Table 28 Standard maximum speed

Model size	Maximum speed m/min
35	180
45	120
55	100
65	75

### Operating temperature

The maximum operating temperature is 120°C and a continuous operation is possible at temperatures up to 100°C. When the temperature exceeds 100°C, consult **IKO**.

In the case of C-Lube Linear Way and the models "with Capillary plates" of special specification, operate below 80°C.

### Cleaning

Do not wash C-Lube Linear Way with organic solvent and/or white kerosene, which have the ability of removing fat, nor leave them in contact with the above agents.

### Oil supply point for lubrication

When lubrication oil is fed by gravity, sufficient amounts of oil may not reach to the raceways which are located higher than the supply point. In such cases, it is necessary to examine the lubrication route and supply point. Consult **IKO** for further information.

### Lubrication of Linear Way Module

A grease nipple is not provided on the slide member of Linear Way Module, but a lubrication hole is provided on it to supply lubricant directly to the steel ball re-circulation route. By preparing a lubricant supply route in the mating machine parts as shown in Fig.18, lubrication can be carried out readily.

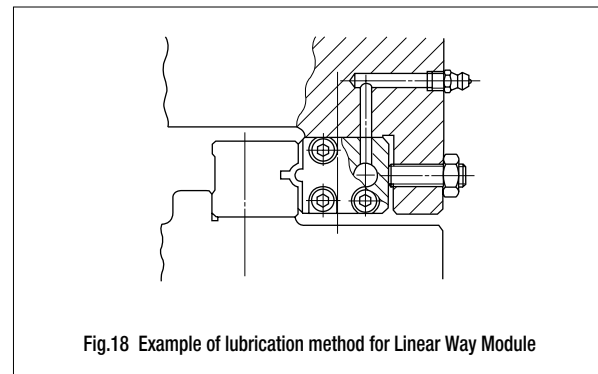

Fig.18 Example of lubrication method for Linear Way Module

## Precautions for Mounting

### When mounting multiple sets at the same time

- Interchangeable specification product  
In the case of an interchangeable specification product, assemble a slide unit and a track rail with the same interchangeable code ("S1" or "S2")
- Non-interchangeable specification product  
Use an assembly of slide unit and track rail as delivered without changing the combination.
- Matched sets to be used as an assembled group  
Special specification products of matched sets (supplemental code "/W") are delivered as a group in which dimensional variations are specially controlled. Mount them without mixing with the sets of another group.

### Assembling a slide unit and a track rail

- Assembling of C-Lube Linear Way ML and Linear Way L  
When assembling C-Lube Linear Way ML or Linear Way L, correctly fit the grooves of the slide unit mounted on a dummy rail (steel ball holder) to the grooves of the track rail, and then move the slide unit gently from the dummy rail to the track rail in parallel direction.

Steel balls are retained in C-Lube Linear Way ML and Linear Way L Ball Retained type, so the slide unit can be separated freely from the track rail. However, the slide unit can be assembled on the track rail much easier by using the dummy rail.

The Linear Way L slide unit of interchangeable specification is delivered as assembled on a dummy rail.

In Linear Way L Ball Non-Retained type, steel balls are not retained. When separating the slide unit from the track rail, a dummy rail (steel ball holder) should be used.

The dummy rail (steel ball holder) is appended as an accessory to models shown in Table 29. The steel ball holder for other models are also available. If required, consult **IKO** for further information.

Table 29 Models to which a steel ball holder is appended

C-Lube Linear Way ML		Linear Way L	
Standard type	Wide Rail type	Standard type	Wide Rail type
<b>MLC 5</b>	<b>MLFC 10</b>	<b>LWL 2</b>	<b>LWLF 4</b>
<b>ML 5</b>	<b>MLF 10</b>	<b>LWLC 3</b>	<b>LWLFC 6</b>
<b>MLC 7</b>	<b>MLFC 14</b>	<b>LWL 3</b>	<b>LWLF 6</b>
<b>ML 7</b>	<b>MLF 14</b>	<b>LWLC 5···B</b>	<b>LWLFC 10···B</b>
<b>MLG 7</b>	<b>MLFG 14</b>	<b>LWL 5···B</b>	<b>LWLF 10···B</b>
<b>MLC 9</b>	<b>MLFC 18</b>	<b>LWLC 7···B</b>	<b>LWLFC 14···B</b>
<b>ML 9</b>	<b>MLF 18</b>	<b>LWL 7···B</b>	<b>LWLF 14···B</b>
<b>MLG 9</b>	<b>MLFG 18</b>	<b>LWLG 7···B</b>	<b>LWLFG 14···B</b>
<b>MLG 12</b>	<b>MLFG 24</b>	<b>LWLC 9···B</b>	<b>LWLFC 18···B</b>
<b>MLG 15</b>	<b>MLFG 30</b>	<b>LWL 9···B</b>	<b>LWLF 18···B</b>
<b>MLG 20</b>	<b>MLFG 42</b>	<b>LWLG 9···B</b>	<b>LWLFG 18···B</b>
—	—	<b>LWLG 12···B</b>	<b>LWLFG 24···B</b>
—	—	<b>LWLG 15···B</b>	<b>LWLFG 30···B</b>
—	—	<b>LWLG 20···B</b>	<b>LWLFG 42···B</b>
—	—	<b>LWLG 25···B</b>	—

Remark : For Linear Way L series, also applicable to high carbon steel products.

- Assembling of types other than C-Lube Linear Way ML and Linear Way L

When assembling the slide unit on the track rail, correctly fit the grooves of the slide unit to the grooves of the track rail and move the slide unit gently in parallel direction. Rough handling will result in seal damage or dropping of steel balls.

The interchangeable specification slide unit is provided with a dummy rail. And, the size 12, 15, 20, 25 and 30 models of Linear Roller Way Super X are appended with a dummy rail. This dummy rail should be used for assembly.

### Handling of C-Lube Linear Way ML, Linear Way L and Linear Way Module LM

In C-Lube Linear Way ML, Linear Way L Ball Retained type and Linear Way Module LM, steel balls are retained with a steel ball retaining band. However, these products must be handled with care to prevent the steel balls from falling out.

### Mounting accuracy

Inadequate mounting accuracy of Linear Way and Linear Roller Way will affect the operating accuracy and life adversely, so mounting must be carried out with care. When multiple sets are mounted, the parallelism between the two mounting surfaces of machines must be prepared, in general, as shown in Table 30. In the case of Linear Way, if mounting parallelism is poor, frictional resistance will steeply increase giving a warning signal, which can be used to perform high accuracy mounting. For details, see "Mounting" on page 128.

Class	Ordinary (No symbol)	High (H)	Precision (P)	Super precision (SP)	Ultra Precision (UP)
Parallelism	30		20	10	6

### Cleaning of mounting surfaces

When mounting Linear Way or Linear Roller Way, first clean all mounting and reference mounting surfaces. (See Fig. 19.)

- Remove burrs and blemishes from the reference mounting surfaces and mounting surfaces of the machine or equipment, on which Linear Way or Linear Roller Way will be mounted, using an oil-stone, etc., and then wipe the surfaces with clean cloth.

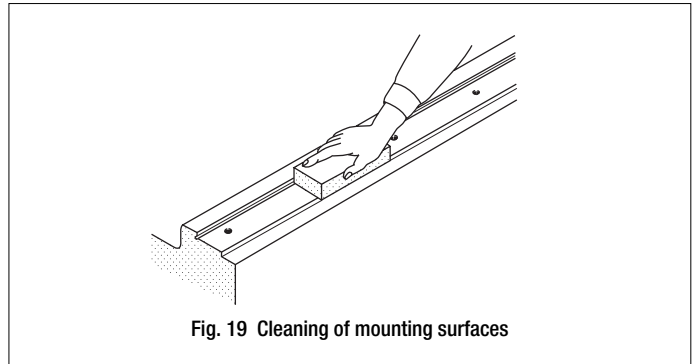

- Remove rust preventive oil and dirt from the reference mounting surfaces and mounting surfaces of Linear Way or Linear Roller Way with clean cloth.

### Plugging-in of caps for rail mounting holes

- When plugging the caps of special specification ("with caps for rail mounting holes, supplemental code /F") into the mounting holes of track rail, tap in the cap gently by applying a flat plate on the top face of the cap until the top face of the cap becomes level with the top face of the track rail.

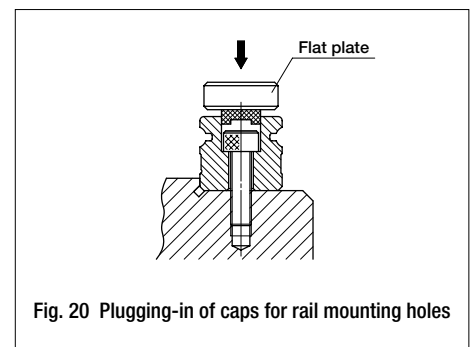

### Tightening torque of mounting bolts

The standard torque values for Linear Way and Linear Roller Way mounting bolts are shown in Tables 31.1 and 31.2. When machines or equipment are subjected to severe vibration, shock, large fluctuating load, or moment load, the bolts should be tightened with a torque 1.2 to 1.5 times higher than the standard torque values shown.

When the mating member material is cast iron or aluminum, tightening torque should be lowered in accordance with the strength characteristics of the material.

Bolt size	Tightening torque N·m	
	Carbon steel bolt (In case strength division 12.9)	Stainless steel bolt (Property division A2-70)
M 3 × 0.5	1.7	1.1
M 4 × 0.7	4.0	2.5
M 5 × 0.8	7.9	5.0
M 6 × 1	13.3	8.5
M 8 × 1.25	32.0	20.4
M 10 × 1.5	62.7	—
M 12 × 1.75	108	—
M 14 × 2	172	—
M 16 × 2	263	—
M 20 × 2.5	512	—
M 24 × 3	882 ( 746)(1)	—
M 30 × 3.5	1 750 (1 480)(1)	—

Note(1) : The values in ( ) show recommended tightening torque for strength division 10.9.  
 Remark 1 : For C-Lube Linear Way ML, Linear Way L, Linear Way LM and the size 8, 10 and 12 models of Linear Way H, see Table 31.2.  
 2 : Tightening torque for the slide unit middle mounting holes of the size 15, 20, 25, 30 and 35 models of Linear Roller Way Super X flange type is recommended to be 70 to 80 % of the values in the table.

Bolt size	Tightening torque N·m	
	Carbon steel bolt (Strength division 8.8)	Stainless steel bolt (Property division A2-70)
M 1 × 0.25	—	0.04
M 1.4 × 0.3	—	0.10
M 1.6 × 0.35	—	0.15
M 2 × 0.4	—	0.31
M 2.3 × 0.4	—	0.48
M 2.5 × 0.45	—	0.62
M 2.6 × 0.45	—	0.70
M 3 × 0.5	1.2	1.1
M 4 × 0.7	2.8	2.5
M 5 × 0.8	5.6	5.0
M 6 × 1	—	8.5

## Mounting Examples

The general mounting procedure for Linear Way and Linear Roller Way is shown in Examples 1 to 3 using a Linear Way as an example. The mounting procedure for Linear Way Module is shown in Example 4.

### Example 1 For general operation

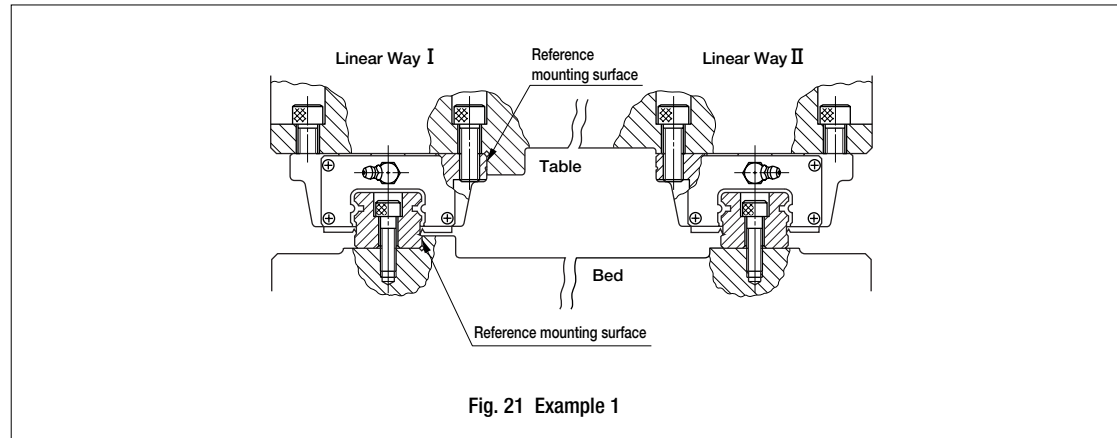

Fig. 21 Example 1

For operations under normal conditions without shocks, prepare one mating reference mounting surface on the table and the bed respectively, and proceed as follows. (See Fig. 21.)

### 1 Cleaning of mounting surfaces

- Remove burrs and blemishes from the reference mounting surfaces and mounting surfaces of the machine using an oil-stone, etc. and then wipe the surfaces with clean cloth. (See Fig. 22.)
- Remove rust preventive oil and dirt from the reference mounting surfaces and mounting surfaces of Linear Way with clean cloth.

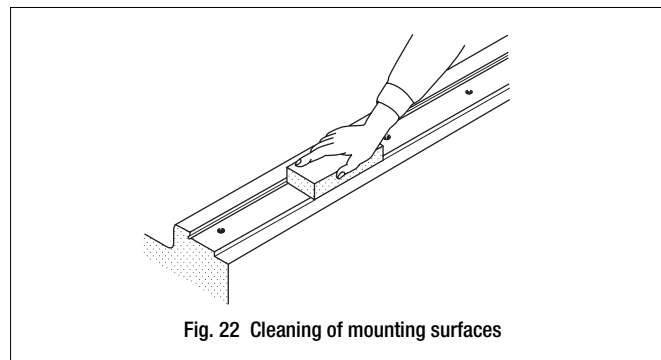

Fig. 22 Cleaning of mounting surfaces

### 2 Temporary fixing of Linear Way I and II track rails

- Correctly fit the reference mounting surface of Linear Way I track rail onto the mating reference mounting surface of the bed, and temporarily fix the track rail with mounting bolts. (See Fig. 23.)  
During installation, ensure that track rail mounting bolts do not interfere with the mounting holes.
- Temporarily fix Linear Way II track rail onto the bed.

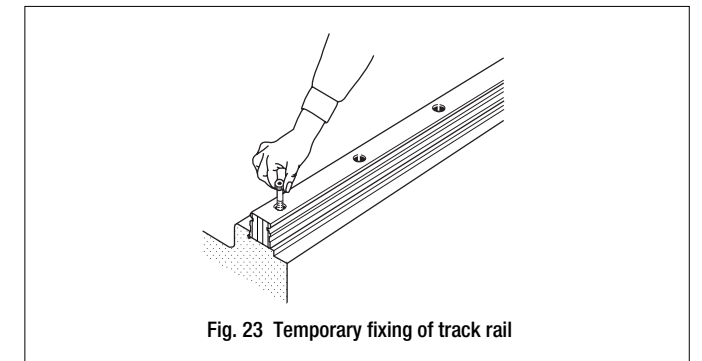

Fig. 23 Temporary fixing of track rail

### 3 Final fixing of Linear Way I track rail

- Firmly push the reference mounting surface of Linear Way I track rail to the mating reference mounting surface of the bed using a small vise or clamp. Tighten the track rail mounting bolt at the position where the vise or clamp is applied. Fix the track rail by progressively moving the position of the vise or clamp from one rail end to the other. (See Fig. 24.)
- At this stage, leave Linear Way II track rail temporarily fixed.

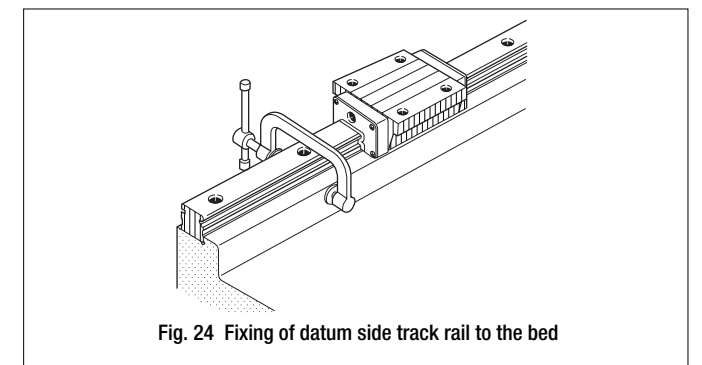

Fig. 24 Fixing of datum side track rail to the bed

### 4 Temporary fixing of Linear Way I and II slide units

- After locating all slide units to their respective table mounting positions, gently place the table on them.
- Temporarily fix Linear Way I and II slide units to the table.

### 5 Final fixing of Linear Way I slide units

- Fix the Linear Way I slide units to the table while correctly fitting the reference mounting surfaces of slide units to the mating reference mounting surface of the table.

### 6 Fixing of Linear Way II slide units

- Correctly fix one of the slide units of Linear Way II in relation to the linear motion direction and leave other slide units temporarily tightened with mounting bolts. (See Fig. 25.)

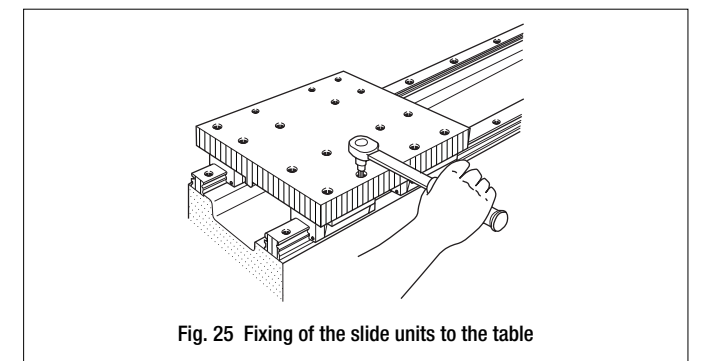

Fig. 25 Fixing of the slide units to the table

### 7 Final fixing of Linear Way II track rail

- While moving the table by hand and ensuring its smooth movement, fix the Linear Way II track rail to the bed with the mounting bolts. During this procedure, tighten the mounting bolt immediately behind the fixed slide unit of Linear Way II, while progressively moving the table from one rail end to the other. (See Fig. 26.)

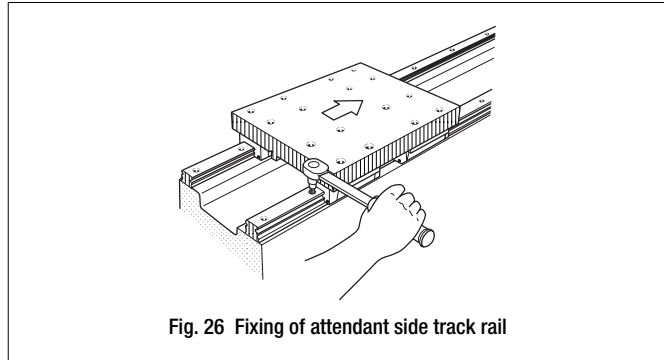

Fig. 26 Fixing of attendant side track rail

### 8 Final fixing of other Linear Way II slide units

- Fix all Linear Way II slide units that have been left temporarily fixed to the table.

### Example 2 Mounting example of Micro Linear Way

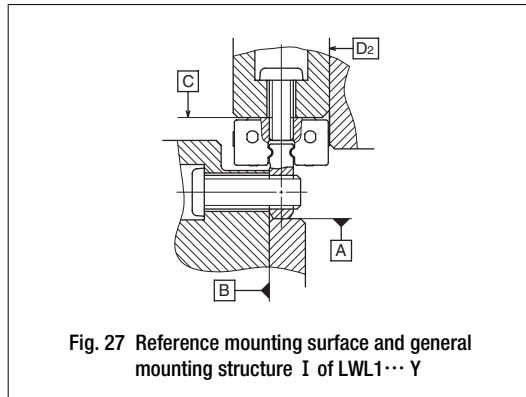

Fig. 27 Reference mounting surface and general mounting structure I of LWL1...Y

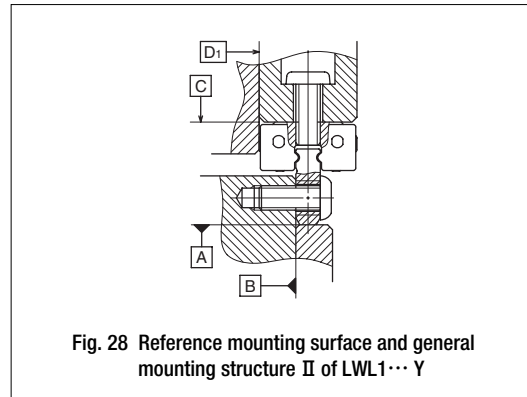

Fig. 28 Reference mounting surface and general mounting structure II of LWL1...Y

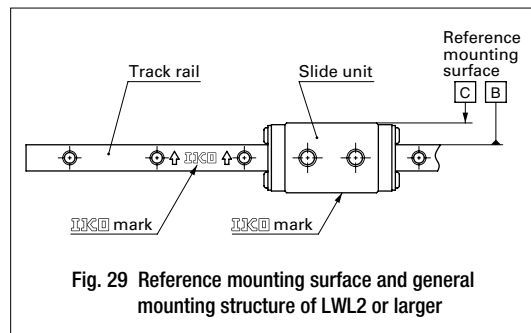

Fig. 29 Reference mounting surface and general mounting structure of LWL2 or larger

### Example 3 Operation requiring accurate movement and rigidity

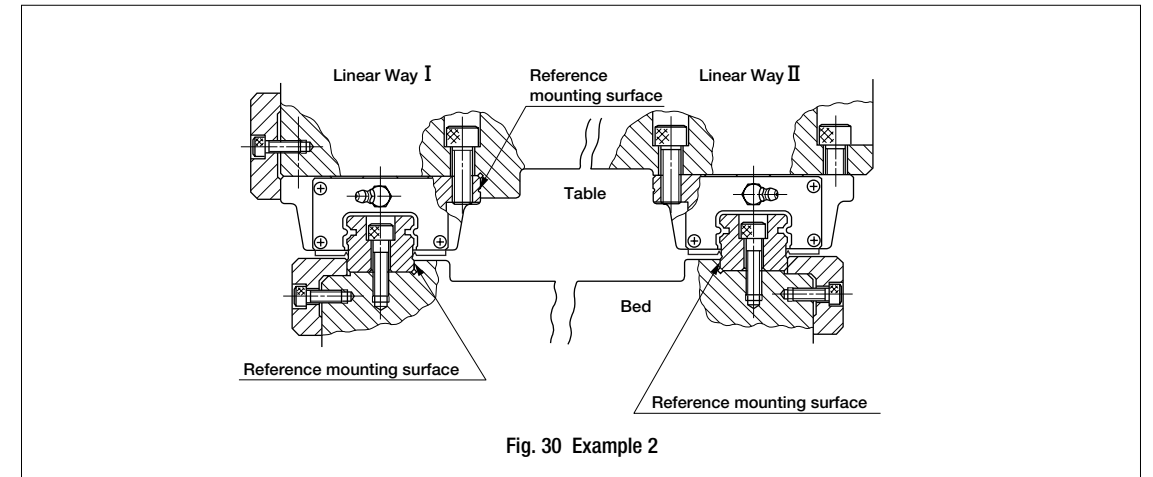

Fig. 30 Example 2

When machines using Linear Way require high running accuracy and rigidity, prepare two mating reference mounting surfaces on the bed and one mating reference mounting surface on the table, then perform the following procedure. (See Fig. 30.)

#### 1 Cleaning of mounting surfaces and reference mounting surfaces

- Remove burrs and blemishes from mounting surfaces and reference mounting surfaces of the machine using an oil-stone, etc., and then wipe the surfaces with clean cloth. (See Fig. 31.)
- Remove rust preventive oil and dirt from Linear Way reference mounting surfaces and mounting surfaces with clean cloth.

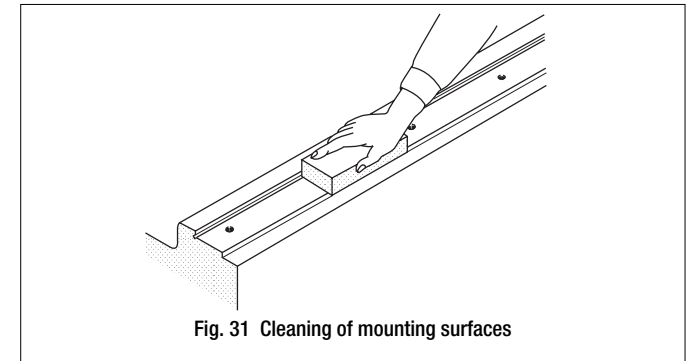

Fig. 31 Cleaning of mounting surfaces

#### 2 Temporary fixing of Linear Way I and II track rails

- Correctly fit the reference mounting surfaces of Linear Way I and II track rails onto the mating reference mounting surfaces of the bed, and temporarily fix the track rails with mounting bolts. (See Fig. 32.)

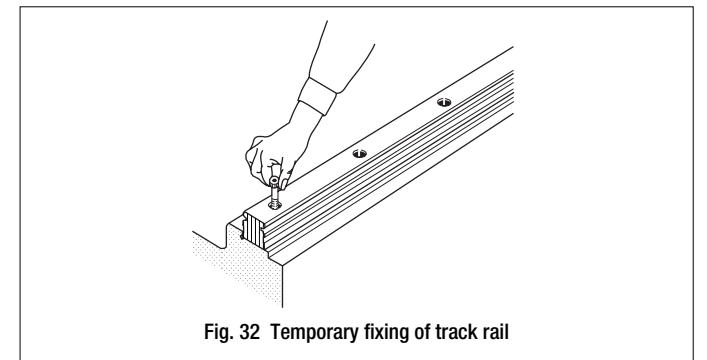

Fig. 32 Temporary fixing of track rail

### 3 Final fixing of Linear Way I and II track rails

- Firmly press the reference mounting surface of Linear Way I track rail to the mating reference surface of the bed with pressure plates or pressure screws. Tighten the mounting bolt of the track rail at the pressure plate or screw position from one end of the track rail to the other in succession. (See Fig. 33.)
- Fix Linear Way II track rail in the same way.

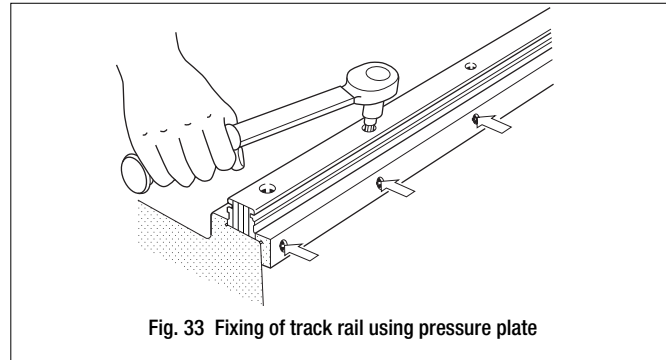

Fig. 33 Fixing of track rail using pressure plate

### 4 Temporary fixing of Linear Way I and II slide units

- After locating all slide units to their respective table mounting positions, gently place the table on them. Temporarily fix Linear Way I and II slide units to the table.

### 5 Final fixing of Linear Way I slide units

- Fix the Linear Way I slide units to the table while correctly fitting the reference mounting surfaces of the slide units to the mating reference mounting surface of the table using pressure plates or pressure screws.

### 6 Final fixing of Linear Way II slide units

- Move the table by hand to ensure smooth movement, then fix the Linear Way II slide units to the table with mounting bolts. (See Fig. 34.)

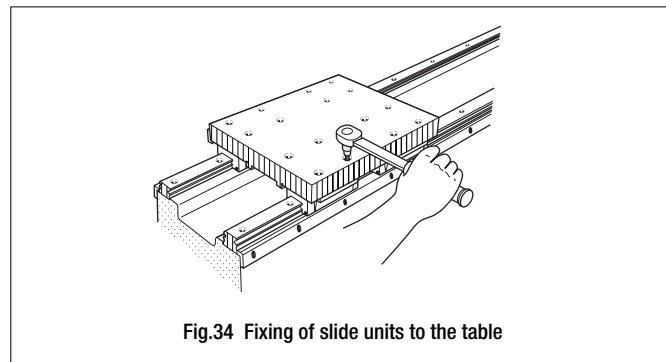

Fig.34 Fixing of slide units to the table

### Example 4 Separate mounting of slide units from track rails

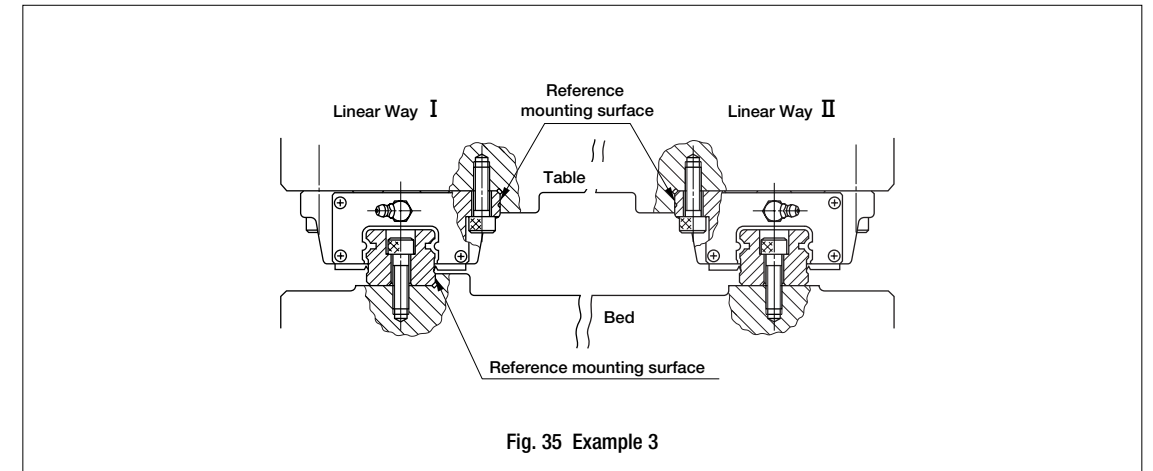

Fig. 35 Example 3

When the slide units assembled on the track rail cannot be securely fixed to the table due to table construction, prepare one reference mounting surface on the bed and two reference mounting surfaces on the table, then proceed as follows. (See Fig. 35.)

### 1 Cleaning of mounting surfaces

- Remove burrs and blemishes from reference mounting surfaces and mounting surfaces of the machine using an oil-stone, etc., and then wipe the surfaces with clean cloth. (See Fig. 36.)
- Remove rust preventive oil and dirt from Linear Way reference mounting surfaces and mounting surfaces with clean cloth.

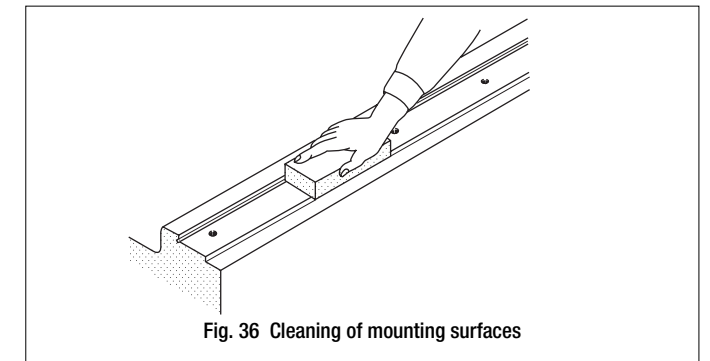

Fig. 36 Cleaning of mounting surfaces

### 2 Temporary fixing of Linear Way I and II track rails

- Correctly fit the reference mounting surface of Linear Way I track rail onto the mating reference mounting surface of the bed, and temporarily fix the track rail with mounting bolts. (See Fig. 37.)  
During installation, ensure that the track rail mounting bolts do not interfere with the mounting holes.
- Temporarily fix Linear Way II track rail onto the bed.

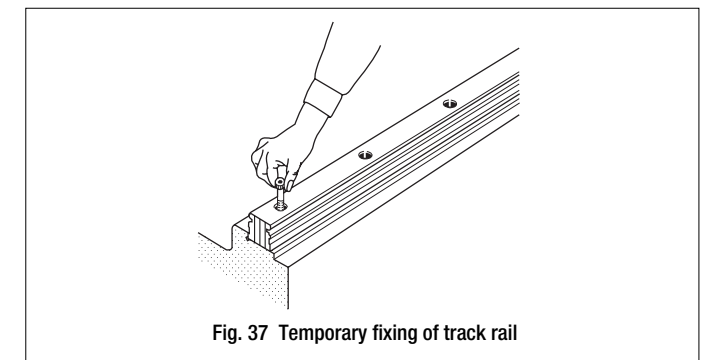
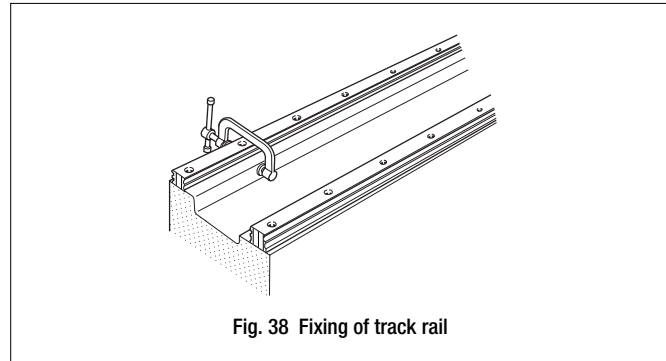

Fig. 37 Temporary fixing of track rail

### 3 Final fixing of Linear Way I track rail

- Firmly push the reference mounting surface of Linear Way I track rail to the mating reference mounting surface of the bed using a small vise or clamp. Tighten the track rail mounting bolt at the position of the vise or clamp. Fix the track rail by progressively moving the vise or clamp from one rail end to the other. (See Fig. 38.)



- At this stage, leave Linear Way II track rail temporarily fixed.

### 4 Separation of slide units from track rails

- After noting the respective markings which identify correct assembly positions of slide units on Linear Way I and II track rails, separate slide units from track rails.

### 5 Fixing of Linear Way I and II slide units

- Correctly fit the reference mounting surfaces of Linear Way I and II slide units to the mating reference mounting surfaces of the table and fix the slide units as shown in the figure. (See Fig. 39.)

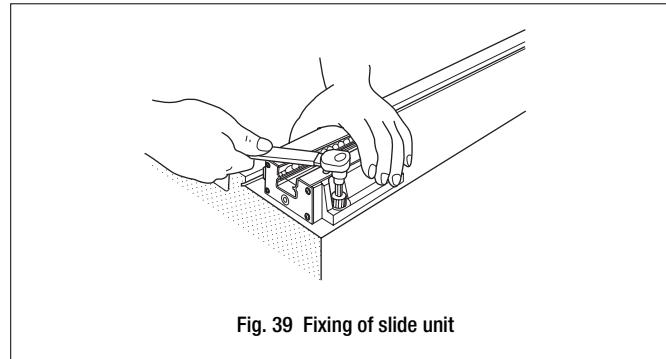

### 6 Installing slide units on track rails

- Gently and gradually install the slide units which are fixed on the table onto the track rails which are fixed or temporarily tightened on the bed. Take care to maintain parallelism of the table to the track rails as the table is slid onto the rails.

### 7 Fixing of Linear Way II track rail

- Fix the track rail of Linear Way II while checking the smooth motion by moving the table. At this time, tighten the mounting bolt right behind the fixed slide unit of Linear Way II just passed. Fix the track rail by repeating this procedure from one rail end to the other.

### Example 5 Assembly of Linear Way Module

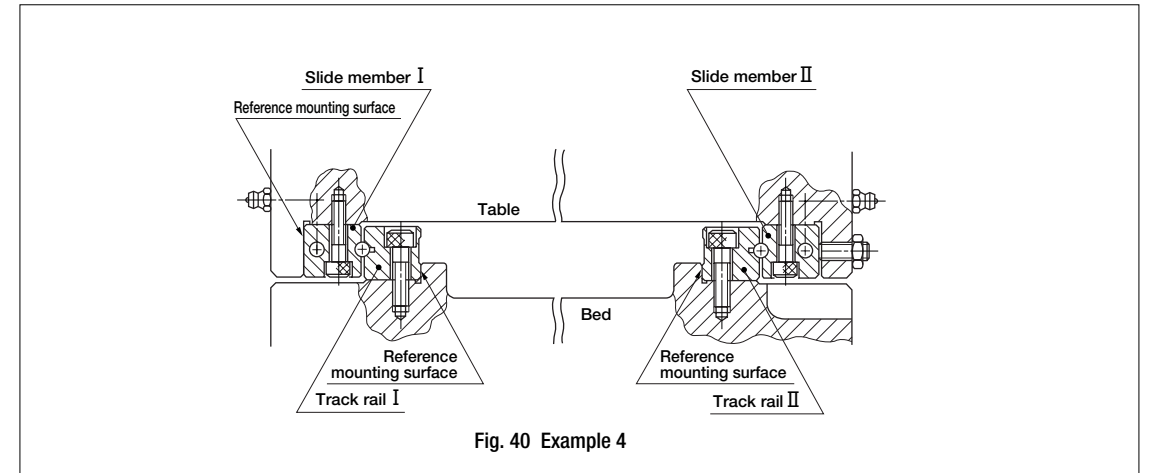

Generally, two sets of Linear Way Modules are used in parallel as shown in Fig. 36. They are usually mounted according to the following procedure. (See Fig. 40.)

### 1 Cleaning of mounting surfaces

- Remove burrs and blemishes from reference mounting surfaces and mounting surfaces of the machine using an oil-stone, etc., and then wipe the surfaces with clean cloth. (See Fig. 41.)
- Remove rust preventive oil and dirt from Linear Way Module reference mounting surfaces and mounting surfaces with clean cloth.

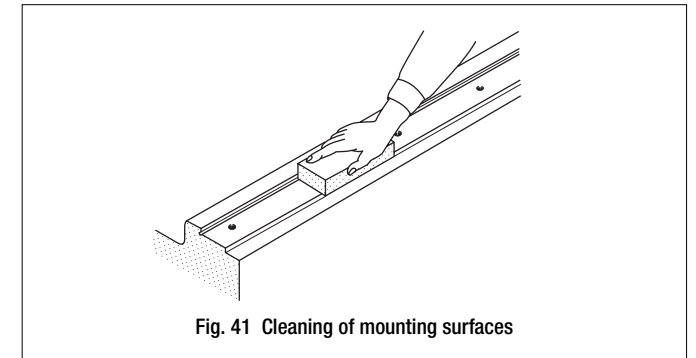

### 2 Fixing of track rails

- Correctly fit the reference mounting surfaces of Track Rails I and II to the reference mounting surfaces of the bed and bring them in close contact using a small vise, etc. Tighten the mounting bolt at the position of the vise. (See Fig. 42.)

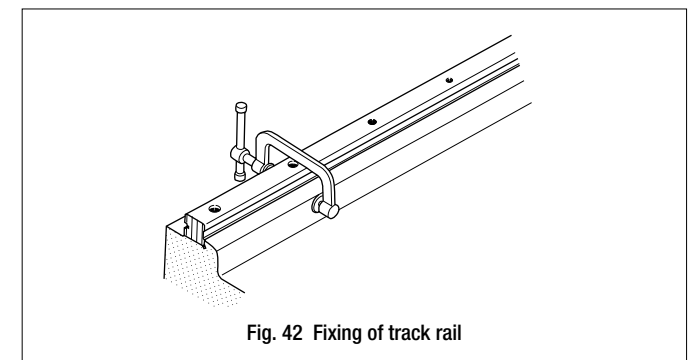

### 3 Fixing of slide members

- Tighten the mounting bolts and fix the slide member I to the table while correctly fitting the reference mounting surface of the slide member to the mating reference mounting surface of the table. Temporarily fix the slide member II. (See Fig. 43.)

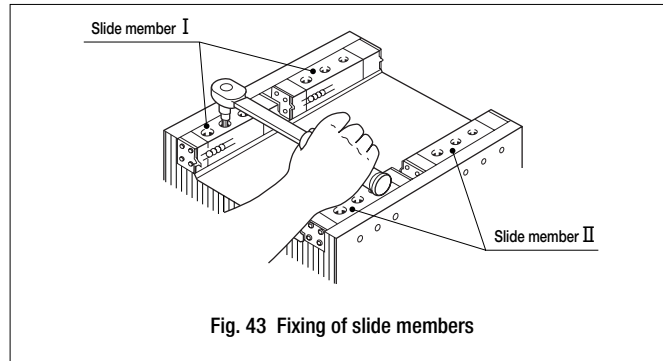

### 4 Installing slide members on track rails

- Gently and gradually install the slide members fixed to the table onto the track rails fixed to the bed, taking care to maintain parallelism between the table and the track rails.

### 5 Final fixing of slide member II

- While measuring the clearance with a dial gauge as shown in Fig. 44, tighten all preload adjusting screws starting from the screw in the center.
- When the dial gauge indicates no deflection while the table is pushed to right and left in the direction perpendicular to the rails, the preload is zero or very light.
- After adjusting preload, fix slide members II by tightening the mounting bolts.

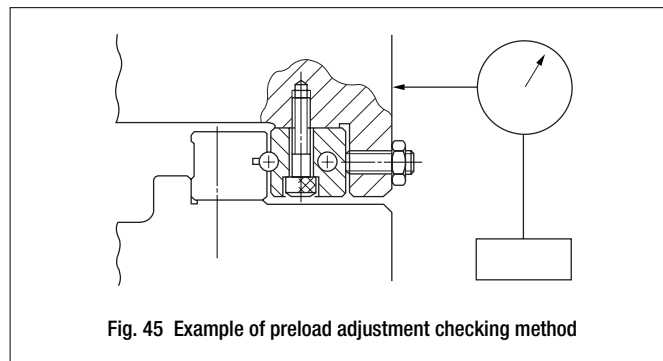
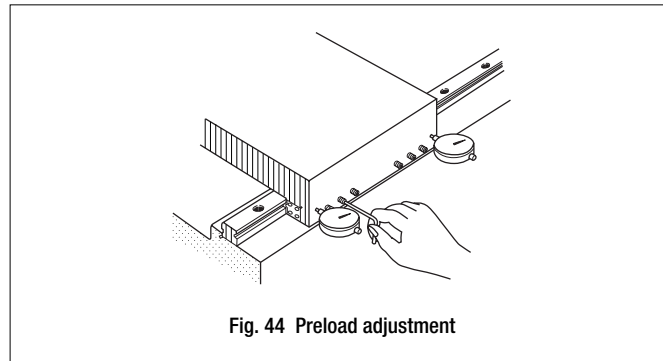

## Mounting methods of datum track rail

The following methods may be used to mount the datum track rails of **IKO** Linear Way and Linear Roller Way. Select the method most suited to the specifications of the machine or equipment.

### 1 Use of mating reference mounting surface of bed

Firmly push the reference mounting surface of the track rail against the mating reference mounting surface of the bed using a small vise or clamp. Tighten the mounting bolt at the position of the vise. Fix the track rail by repeating this procedure from one end of the rail to the other in succession.

### 2 Use of a temporary reference surface

Prepare a temporary reference surface near the mounting surface of the bed and temporarily fix the track rail. Next, fix an indicator stand on the top face of the slide unit as shown in Fig. 46. Apply the indicator probe to the temporary reference surface and fix the track rail by tightening the mounting bolts in succession from one end of the track rail to the other while checking the straightness of the slide unit movement.

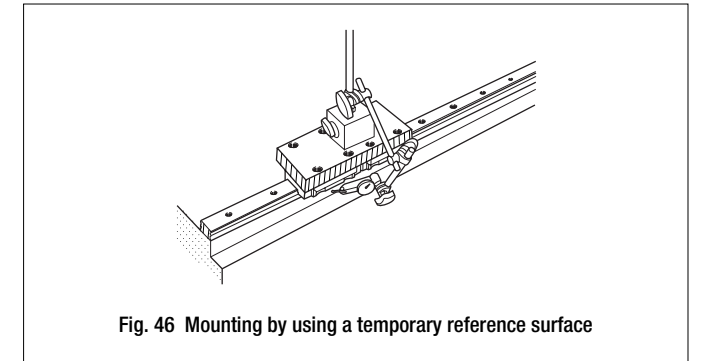

### 3 Use of straight-edge

After temporarily fixing the track rail, apply an indicator probe to the reference mounting surface of the track rail as shown in Fig. 47. Tighten the mounting bolts one by one, while progressively checking the straightness of the track rail in reference to the straight-edge from one end of the track rail to the other.

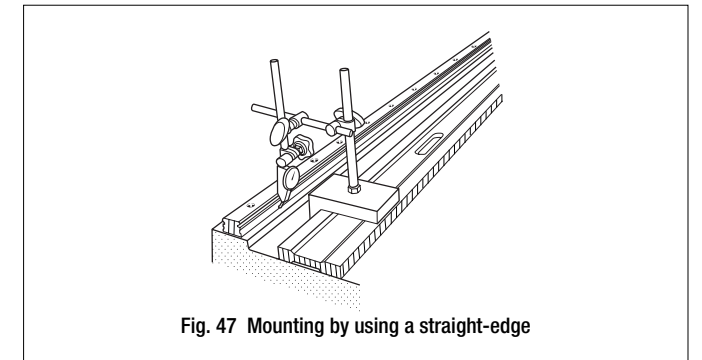



## Mounting methods of attendant track rail

The following methods may be used to mount the attendant track rail. Select the method most suited to the specifications of the machine or equipment.

### ① Use of reference mounting surface

Firmly push the reference mounting surface of the track rail against the reference mounting surface of the bed using a pressure plate or small vise. Fix the track rail by tightening the mounting bolt at the position of the pressure plate or vise. Tighten the mounting bolts one by one starting from one end of the track rail to the other.

### ② Use of mounted datum track rail as the reference

Fix the datum track rail correctly, fix one attendant slide unit correctly in the direction of motion, and temporarily fix the other slide units and the attendant track rail. Then, fix the attendant track rail by tightening the mounting bolts one by one from one end of the track rail to the other while checking the smooth movement.

### ③ Use of straight-edge

After fixing the track rail temporarily, apply the indicator probe to the reference mounting surface of the track rail (as shown in Fig. 44). While checking the straightness in reference to the straight-edge, fix the attendant track rail by tightening the mounting bolts one by one from one end of the track rail to the other.

### ④ Use of datum side Linear Way

As shown in Fig. 48, set an indicator stand on the top face of the datum slide unit and apply the indicator probe to the reference mounting surface of the attendant track rail. While checking parallelism of the two rails, fix the attendant rail by tightening mounting bolts one by one from one end of the track rail to the other.

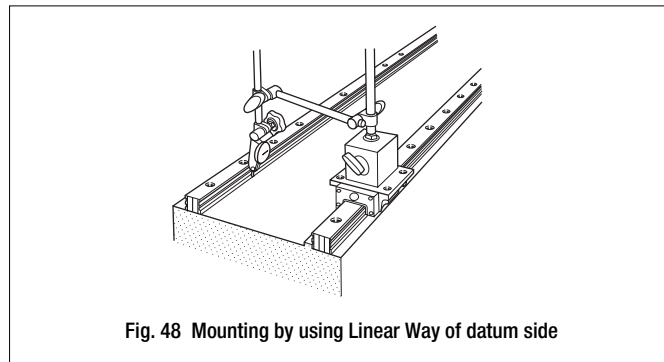

Fig. 48 Mounting by using Linear Way of datum side

## Mounting method for butt-jointing track rails

When using butt-jointing track rails, indicate whether a butt-jointing track rail of special specification (non-interchangeable specification, supplemental code "/A") or a butt-jointing interchangeable track rail (interchangeable specification, supplemental code "/T") is to be mounted.

For butt-jointing track rails of non-interchangeable specification, a match mark as shown in Fig. 49 is indicated on the top face of track rail end. Procedures for mounting jointing track rails are generally as follows.

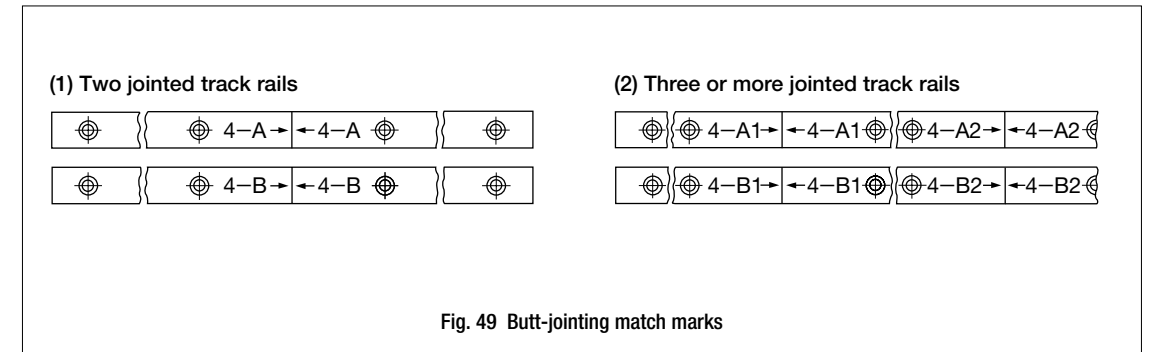

Fig. 49 Butt-jointing match marks

① Joint the track rails end-to-end in accordance with the match marks, and temporarily fix the rails onto the bed. The butt-jointing interchangeable track rail of interchangeable specification does not require matching butt-jointing rail ends, because the rail is prepared for free combination.

② Fit the reference mounting surfaces of the track rails onto the reference mounting surface of the bed, then fix all track rails one by one. While performing this procedure, tightly press the reference mounting surface of each track rail with a small vise, etc. against the reference mounting surface of the bed at the butt-jointing position so that the track rails at the butt-jointing position are connected without a step. (See Fig. 50.)

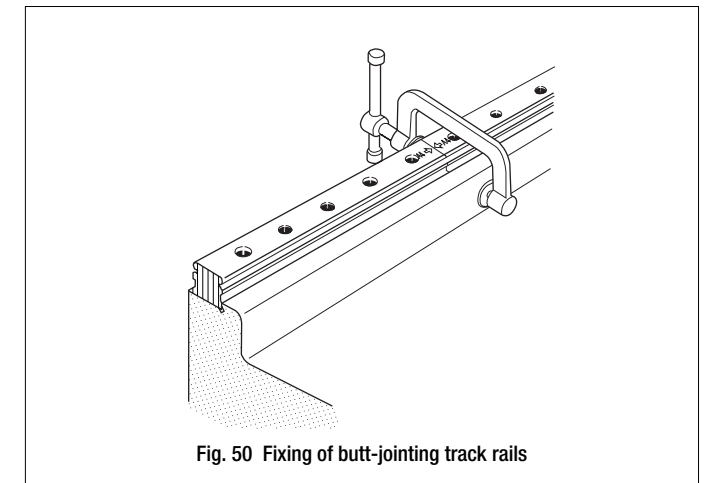
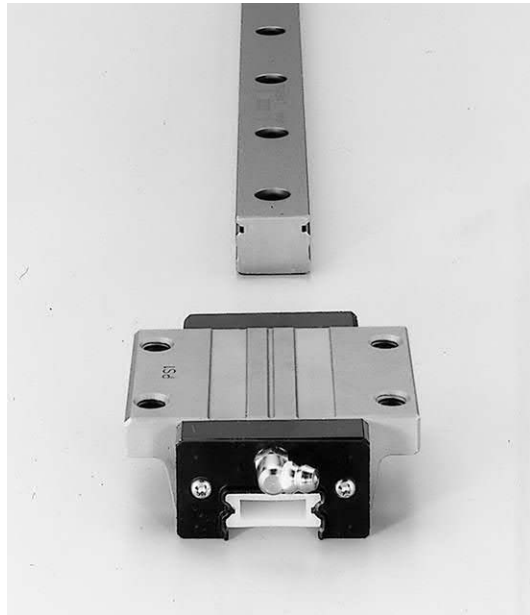

Fig. 50 Fixing of butt-jointing track rails



# C-Lube Linear Ways

Description of each series and Table of dimensions

# A

**Miniature type**  
**C-Lube Linear Way ML**  
Page A-2 to A-17



**Compact type**  
**C-Lube Linear Way ME**  
Page A-18 to A-39



**High Rigidity type**  
**C-Lube Linear Way MH**  
Page A-40 to A-61



**U-shaped track rail type**  
**C-Lube Linear Way MUL**  
Page A-62 to A-69





**High Rigidity type**  
**C-Lube Linear Roller Way Super MX**  
Page A-70 to A-95



**U-shaped track rail type**  
**C-Lube Linear Ball Spline MAG**  
Page A-100 to A-109



In the table of dimensions, standard products are referred to using identification numbers marked with . The identification numbers marked with  refer to our semi-standard products.

# C-Lube Linear Way ML

## ML/MLF

**IKO C-Lube Linear Way ML** is a linear motion rolling guide, incorporating the C-Lube as a components part for lubrication in the slide unit of miniature type Linear Way L series to achieve maintenance free operations for a long period of time.

### Long-term maintenance free

The lubricant in the C-Lube keeps the lubrication performance for a long period of time and achieves long-term maintenance free operations. (5 years and 20,000km)  
So man-hours for troublesome lubrication control can be reduced.

### Lightweight and compact

The C-Lube is incorporated in the lightweight and compact slide unit of miniature type Linear Way L series without changing the external dimensions of the slide unit.

### Smooth and light motion

As the C-Lube is not in contact with the track rail, frictional resistance does not increase. A smooth and light motion is ensured.

### Stainless Steel

The metal components are manufactured from corrosion resistant stainless steel. So this series is most suitable for use in clean rooms and also for applications where the use of lubricants and rust preventive oil should be avoided or kept to a minimum.

### Ball retained type

The slide unit incorporates ball retaining bands, which prevent steel balls from dropping when the slide unit is separated from the track rail. So handling is easy.

### Interchangeability

The track rails and the slide units of interchangeable specification can be handled separately and can be assembled to make a set as required. Three types of slide units with different lengths are prepared. The best type and size can be selected these entire slide units can be freely assembled on the same track rail.

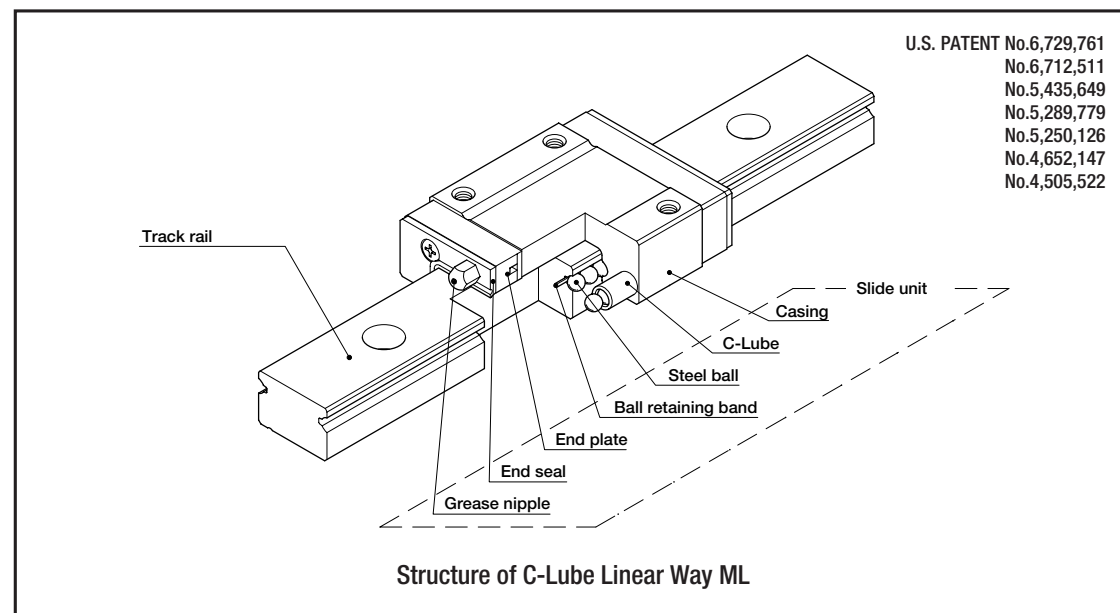

## Variation of IKO C-Lube Linear Way ML

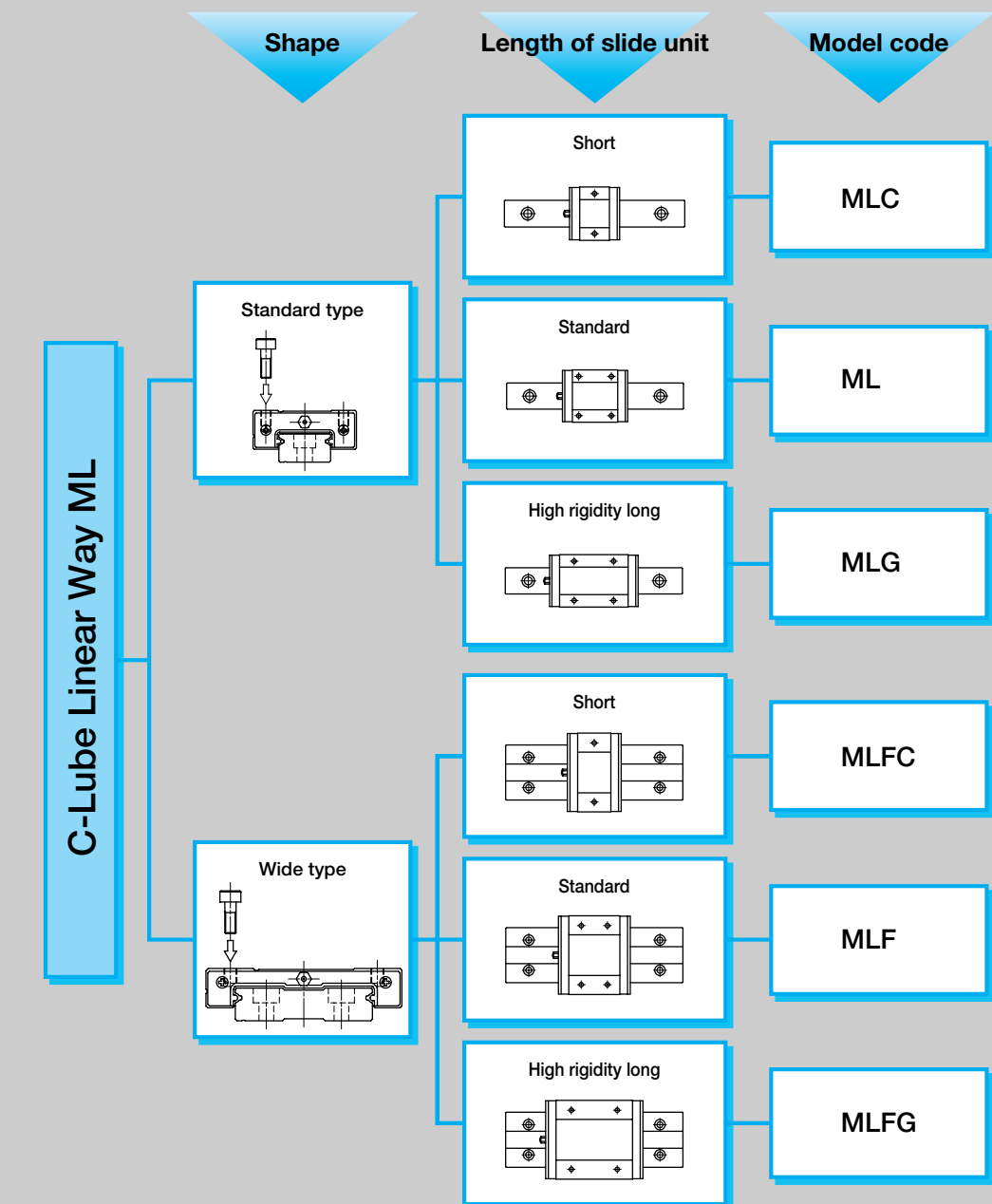

## ● Identification number and specification

The specification of C-Lube Linear Way ML is indicated by the identification number, consisting of a model code, a size, a part code, a preload symbol, a classification symbol and any supplemental codes. For details of each specification, see page 78.

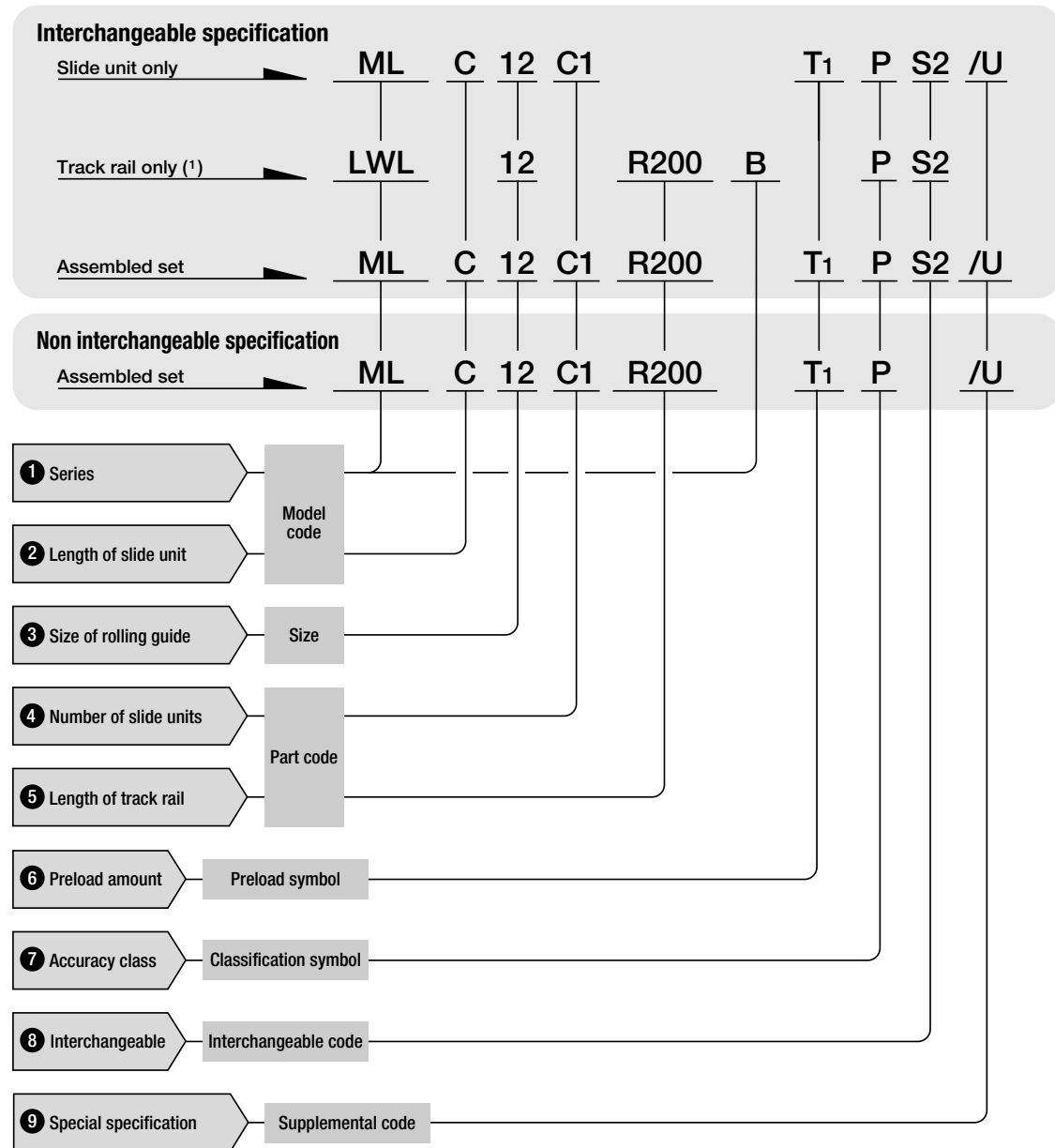

Note(1) : In case ordering track rail only, model code should be changed as shown below.  
 Track rail of interchangeable ML → Model code LWL...B (Ex: LWL9R160BHS2)  
 Track rail of interchangeable MLF → Model code LWLF...B (Ex: LWLF42R320BHS2)

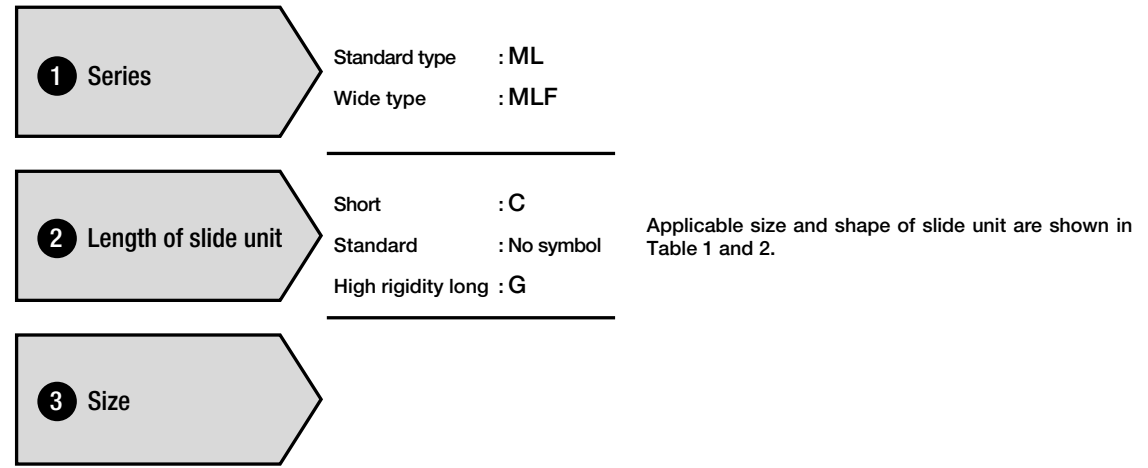

Table 1 Type and size of standard type C-Lube Linear Way ML

Size	Type	Stainless steel		
		Short MLC	Standard ML	High rigidity long MLG
5		☆	☆	—
7		☆	☆	☆
9		☆	☆	☆
12		☆	☆	☆
15		☆	☆	☆
20		☆	☆	☆
25		☆	☆	☆

Remark : The mark ☆ indicates that it is also applicable to interchangeable specification.

Table 2 Type and size of wide type C-Lube Linear Way MLF

Size	Type	Stainless steel		
		Short MLFC	Standard MLF	High rigidity long MLFG
10		☆	☆	—
14		☆	☆	☆
18		☆	☆	☆
24		☆	☆	☆
30		☆	☆	☆
42		☆	☆	☆

Remark : The mark ☆ indicates that it is also applicable to interchangeable specification.

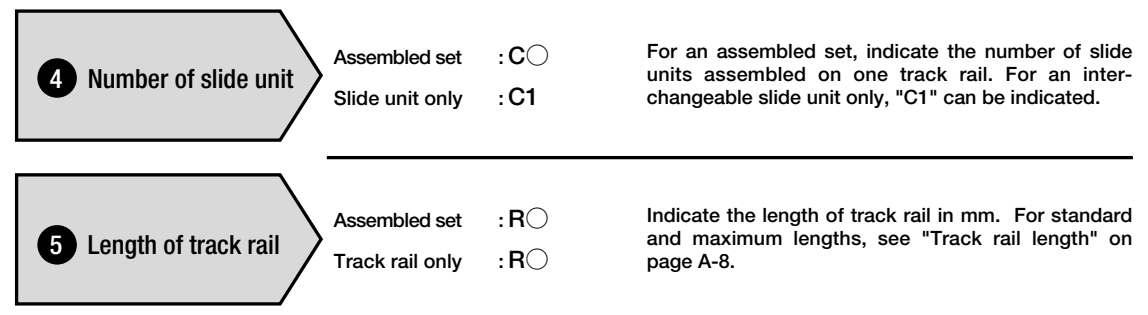

**6 Preload amount**

Clearance : T0 Specify this items for an assembled set or an interchangeable single slide unit.  
 Standard : No symbol Applicable preload and size are shown in Table 3.  
 Light preload : T1 For detail of preload amount, see page 86.

Table 3 Preload of C-Lube Linear Way ML/MLF

Size		Preload and symbol		
Standard type	Wide type	Clearance (T <sub>0</sub> )	Standard (No symbol)	Light preload (T <sub>1</sub> )
5	10	☆	☆	—
7	14	☆	☆	☆
9	18	☆	☆	☆
12	24	☆	☆	☆
15	30	☆	☆	☆
20	42	☆	☆	☆
25	—	☆	☆	☆

Remark : The mark ☆ indicates that it is also applicable to interchangeable specification. Only standard preload is applicable for/HB. (Ceramic ball specification)

**7 Accuracy class**

High class : H In interchangeable specification, please combine same accuracy codes on both slide unit and track rail. For detail of accuracy, see page 81.  
 Precision class : P

**8 Interchangeable**

Interchangeable : S2 Specify this item for the interchangeable specification products. Assemble track rails and slide units with the same interchangeable code.

**9 Special specifications**

Applicable special specifications are shown in Table 4. When a combination of several special specifications is required, please refer Table 5 and arrange their supplemental codes in alphabetical order. For detail of specifications, see page 88.

Table 4 Applicable specifications

Specifications	Supplemental code	Assembled set	Track rail only	Slide unit only	Dimension
Butt jointing track rail	A	○	—	—	
Opposite reference surfaces arrangement	D	☆	—	—	
Specified rail mounting hole positions	E	☆	☆	—	
Ceramic ball specification	HB	○ <sup>(1)</sup>	—	—	
Appending inspection sheet	I	○	—	—	
Black chrome surface treatment	LR	○ <sup>(2)</sup>	—	—	
Without track rail mounting bolts	MN	☆	☆	—	
No rubber end seals	N	☆	—	☆	
Track rail with stopper pins	S	○	—	—	See Table 6
Under seals	U	☆ <sup>(3)</sup>	—	☆ <sup>(3)</sup>	See Table 7
Matched sets to be used as an assembled group	W	○	—	—	

Note<sup>(1)</sup> : Applicable to size 7, 9, 12 and 15.

<sup>(2)</sup> : Not applicable to size 5 and 10.

<sup>(3)</sup> : Not applicable to size 5, 7, 10 and 14.

Remark : The mark ☆ indicates that it is also applicable to interchangeable specification.

Table 5 Combination of special specifications

D	○																				
E	—	—																			
HB	○	○	○																		
I	○	○	○	○																	
LR	—	○	○	○	○																
MN	○	☆	☆	○	○	○															
N	○	☆	☆	○	○	○	○	☆													
S	○	○	○	○	○	○	○	○	○												
U	○	☆	☆	○	○	○	○	☆	—	○											
W	○	○	—	○	○	○	○	○	○	○	○										
	A	D	E	HB	I	LR	MN	N	S	U											

Remark 1 : In the table, the mark ○ indicates that this combination can be made.  
 2 : The mark ☆ indicates that the combination is available for also interchangeable specification.  
 3 : When a combination of several special specifications is required, arrange their supplemental codes in alphabetical order.

Table 6 Dimension of track rail with stopper pins (Supplemental code: /S)

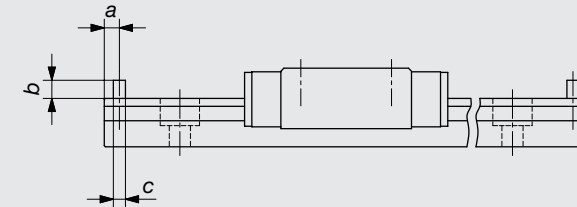

Model number	a	b	c
ML 5	2	2	1.6
ML 7	2.5	2.5	2
ML 9		3	
ML 12		4	
ML 15		5	
ML 20			
ML 25	3.5		

Model number	a	b	c	
MLF 10	2.5	2	1.6	
MLF 14		3	2	
MLF 18				4
MLF 24				
MLF 30		5		
MLF 42				

Remark : The table shows representative model numbers but is also applicable to all types of the same size.

Table 7 H<sub>1</sub> dimension of slide unit with under seals (Supplemental code: /U)

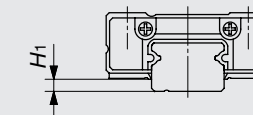

Model number	H <sub>1</sub>
ML 9	1
ML 12	2
ML 15	3
ML 20	4
ML 25	5 <sup>(1)</sup>

Model number	H <sub>1</sub>
MLF 18	2
MLF 24	
MLF 30	
MLF 42	3

Note<sup>(1)</sup> : H<sub>1</sub> dimension of size 25 (ML25) is the same as the dimension without under seals.

Remark : The table shows representative model numbers but is applicable to all models of the same size of ML and MLF series.

## Track rail length

Standard and maximum lengths of track rail are shown in Table 8.1 and 8.2. Track rail in any lengths are also available. Simply indicate the necessary length of track rail in millimeter (mm) in the identification number.

- In non-interchangeable specification, for track rail longer than the maximum length shown in Table 8.1 and 8.2, butt-jointing track rails are available upon request. In this case, indicate supplemental code "/A" in the identification number.
- E dimensions at both ends are the same unless otherwise specified. To change these dimensions, specify the specified rail mounting hole positions (supplemental code "/E") of special specification.

Table 8.1 C-Lube Linear Way ML (Standard type) Standard and maximum lengths of track rails

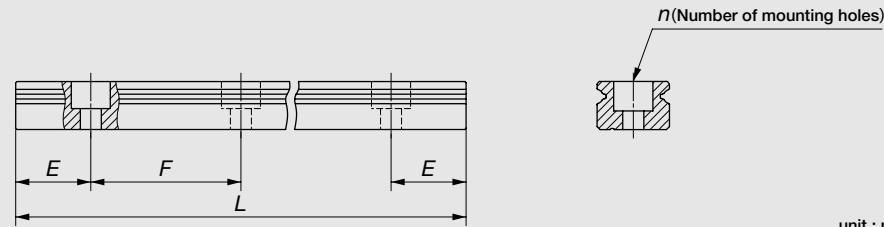

Model number	ML 5	ML 7	ML 9	ML 12
Item				
Standard length $L(n)$	60( 4) 90( 6) 105( 7) 120( 8) 150(10)	60( 4) 90( 6) 120( 8) 150(10) 180(12) 240(16)	60( 3) 80( 4) 120( 6) 160( 8) 220(11) 280(14)	100( 4) 150( 6) 200( 8) 275(11) 350(14) 475(19)
Mounting hole pitch $F$	15	15	20	25
$E$	7.5	7.5	10	12.5
Reference dimension $E^{(1)}$	Over (Incl.) 4 Under 11.5	4.5 12	4.5 14.5	5 17.5
Maximum length <sup>(2)</sup>	210 (510)	300 (990)	860 (1 200)	1 000 (1 450)
Maximum number of track rails for butt jointing	5	7	2	2
Maximum length of butt jointing track rails	915	1 905	1 660	1 925
Model number	ML 15	ML 20	ML 25	
Item				
Standard length $L(n)$	160( 4) 240( 6) 320( 8) 440(11) 560(14) 680(17)	180( 3) 240( 4) 360( 6) 480( 8) 660(11) 840(14)	240( 4) 300( 5) 360( 6) 480( 8) 660(11) 900(15)	
Mounting hole pitch $F$	40	60	60	
$E$	20	30	30	
Reference dimension $E^{(1)}$	Over (Incl.) 5.5 Under 25.5	8 38	9 39	
Maximum length <sup>(2)</sup>	1 000 (1 480)	960 (1 800)	960 (1 800)	
Maximum number of track rails for butt jointing	2	2	2	
Maximum length of butt jointing track rails	1 880	1 740	1 740	

Note(1) : Not applied to optional specification "track rail stopper pins" (supplemental code "/S")

(2) : The track rails can be manufactured up to the maximum length shown in parentheses. If required, please consult **IKO**.

Remark 1 : The above table shows representative model numbers but is applicable to all models of the same size.

2 : "Maximum number of butt-jointing track rails" and "Maximum length of butt-jointing track rails" do not apply to the track rails of interchangeable specification and tapped rail specification.

Table 8.2 C-Lube Linear Way MLF (Wide type) Standard and maximum lengths of track rails

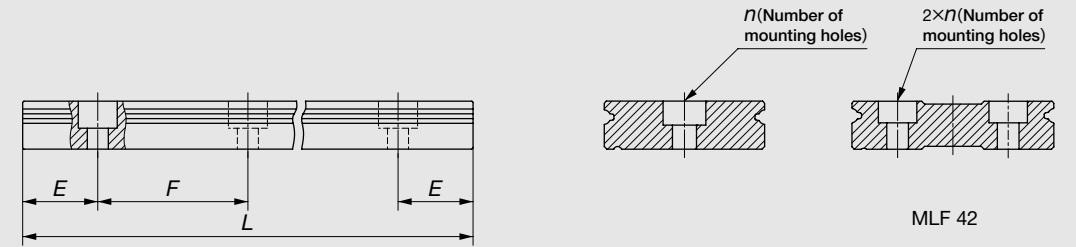

Model number	MLF 10	MLF 14	MLF 18	MLF 24
Item				
Standard length $L(n)$	60( 3) 80( 4) 120( 6) 160( 8) 220(11) 280(14)	90( 3) 120( 4) 150( 5) 180( 6) 240( 8) 300(10)	90( 3) 120( 4) 150( 5) 180( 6) 240( 8) 300(10)	120( 3) 160( 4) 240( 6) 320( 8) 400(10) 480(12)
Mounting hole pitch $F$	20	30	30	40
$E$	10	15	15	20
Reference dimension $E^{(1)}$	Over (Incl.) 4.5 Under 14.5	5.5 20.5	5.5 20.5	6.5 26.5
Maximum length <sup>(2)</sup>	300 (500)	300 (990)	690 (1 860)	680 (1 960)
Maximum number of track rails for butt jointing	7	8	3	3
Maximum length of butt jointing track rails	1 840	1 950	1 920	1 840
Model number	MLF 30	MLF 42		
Item				
Standard length $L(n)$	160( 4) 240( 6) 320( 8) 440(11) 560(14) 680(17)	160( 4) 240( 6) 320( 8) 440(11) 560(14) 680(17)		
Mounting hole pitch $F$	40	40		
$E$	20	20		
Reference dimension $E^{(1)}$	Over (Incl.) 6.5 Under 26.5	6.5 26.5		
Maximum length <sup>(2)</sup>	680 (2 000)	680 (2 000)		
Maximum number of track rails for butt jointing	3	3		
Maximum length of butt jointing track rails	1 840	1 840		

Note(1) : Not applied to optional specification "track rail stopper pins" (supplemental code "/S")

(2) : The track rails can be manufactured up to the maximum length shown in parentheses. If required, please consult **IKO**.

Remark 1 : The above table shows representative model numbers but is applicable to all models of the same size.

2 : "Maximum number of butt-jointing track rails" and "Maximum length of butt-jointing track rails" do not apply to the track rails of interchangeable specification and tapped rail specification.

MLC  
ML  
MLG

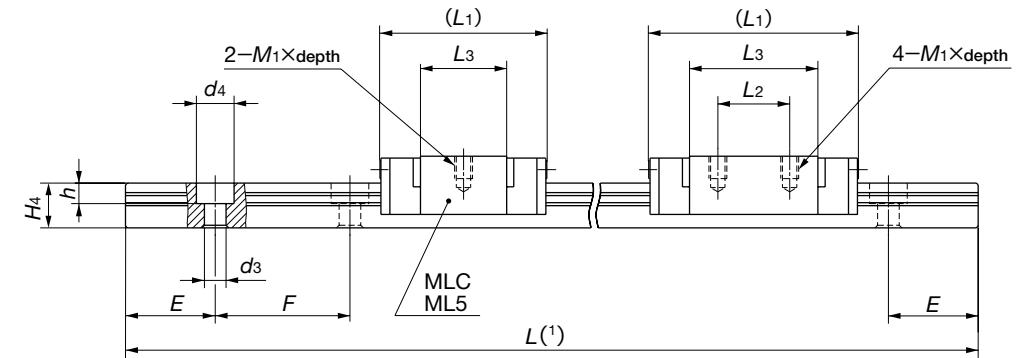
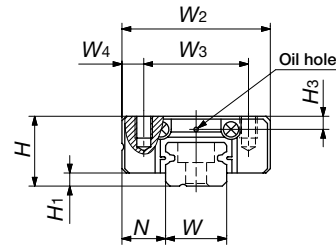

Model number	Interchangeable	Mass (Reference) g		Dimension of assembly mm			Dimension of slide unit mm							
		Slide unit	Track rail (per 100mm)	H	H <sub>1</sub>	N	W <sub>2</sub>	W <sub>3</sub>	W <sub>4</sub>	L <sub>1</sub>	L <sub>2</sub>	L <sub>3</sub>	M <sub>1</sub> × depth	
MLC 5	☆	3.4	12	6	1	3.5	12	8	2	16	-	9.6	M2 × 1.5	
ML 5	☆	4.3								19		12.6		
MLC 7	☆	6.7	22	8	1.5	5	17	12	2.5	19	-	9.6	M2 × 2.5	
ML 7	☆	9.1								23.5		8		14.3
MLG 7	☆	13								31		12		21.6
MLC 9	☆	11	35	10	2	5.5	20	15	2.5	21.5	-	11.9	M3 × 3	
ML 9	☆	18								30		10		20.8
MLG 9	☆	26								40.5		15		30.9
MLC 12	☆	22	65	13	3	7.5	27	20	3.5	25	-	13	M3 × 3.5	
ML 12	☆	34								34		15		21.6
MLG 12	☆	48								44		20		32

H <sub>3</sub>	Dimension of track rail mm								Appended mounting bolt for track rail mm Bolt size x length	Basic dynamic load rating <sup>(2)</sup> C N	Basic static load rating <sup>(2)</sup> C <sub>0</sub> N	Static moment rating <sup>(2)</sup>		
	W	H <sub>4</sub>	d <sub>3</sub>	d <sub>4</sub>	h	E	F	T <sub>0</sub> N·m				T <sub>X</sub> N·m	T <sub>Y</sub> N·m	
1.2	5	3.7	2.4	3.6	0.8	7.5	15	Cross-recessed head cap screw for precision equipment M2×6	562	841	2.2	1.4 8.5	1.2 7.2	
1.5	7	5	2.4	4.2	2.3	7.5	15	Hexagon socket head bolt M2×6	937	1 140	4.1	1.8 14.9	1.5 12.5	
									1 330	1 890	6.9	4.7 28.2	3.9 23.6	
									1 690	2 650	9.7	8.8 50.7	7.4 42.5	
2.2	9	6	3.5	6	3.5	10	20	Hexagon socket head bolt M3×8	1 180	1 480	6.9	2.9 21.4	2.4 18.0	
									1 810	2 760	12.8	9.1 51.1	7.6 42.9	
									2 370	4 030	18.7	18.7 98.3	15.7 82.5	
2.7	12	8	3.5	6.5	4.5	12.5	25	Hexagon socket head bolt M3×8	2 210	2 380	14.8	5.3 41.7	4.5 35.0	
									3 330	4 290	26.6	15.4 93.1	12.9 78.2	
									4 310	6 200	38.4	30.6 168	25.7 141	

Note<sup>(1)</sup>: Track rail lengths L are shown in Table 8.1 on page A-8.

<sup>(2)</sup>: The directions of basic dynamic load rating (C), basic static load rating (C<sub>0</sub>) and static moment rating (T<sub>0</sub>, T<sub>X</sub> and T<sub>Y</sub>) are shown in the sketches below. The upper values in the T<sub>X</sub> and T<sub>Y</sub> column apply to one slide unit, and the lower values apply to two units in close contact.

Remark 1: The mark ☆ indicates that it is also applicable to interchangeable specification.

2: The appended bolts for mounting track rails are stainless hexagon socket head bolts of JIS B1176 or equivalent, or stainless cross-recessed head cap screws for precision equipment.

3: Oil hole is provided for ML5 to ML12 models.

4: For specification of oil hole, see page 101.

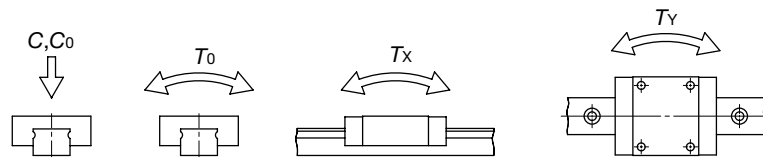

Example of identification number for assembled set (For details, see "Identification number and specification".)

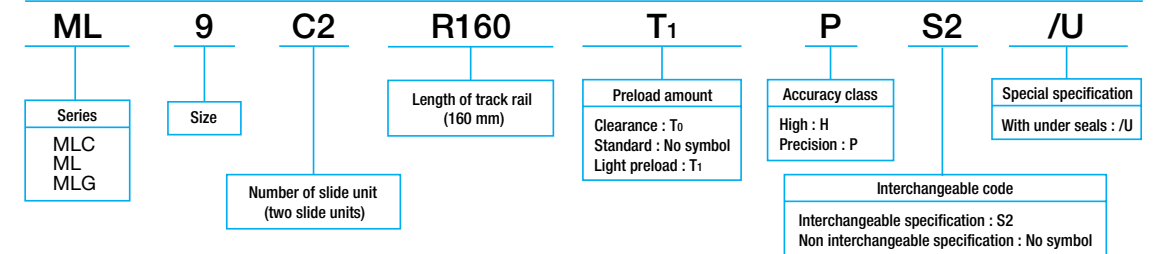

※In case ordering track rail only, model code is changed as shown below.  
Track rail of interchangeable ML ⇒ Model code LWL...B (Ex: LWL9R160BPS2)



MLC  
ML  
MLG

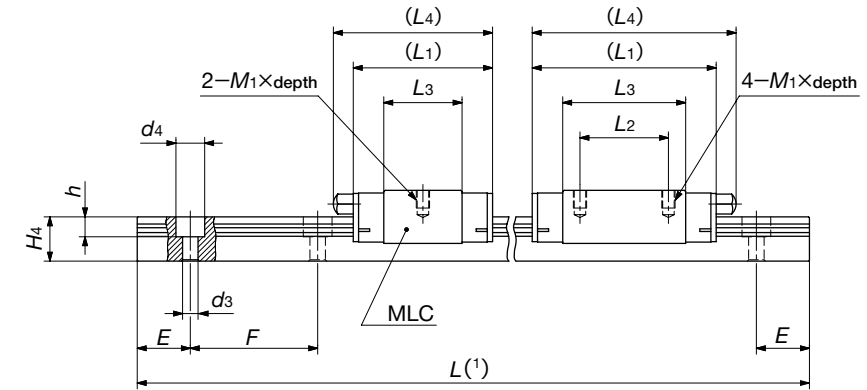
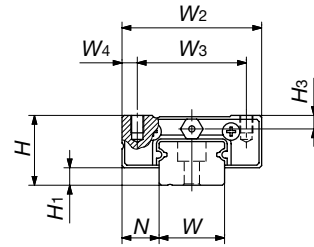

Model number	Interchangeable	Mass (Reference) g		Dimension of assembly mm			Dimension of slide unit mm							
		Slide unit	Track rail (per 100mm)	H	H <sub>1</sub>	N	W <sub>2</sub>	W <sub>3</sub>	W <sub>4</sub>	L <sub>1</sub>	L <sub>2</sub>	L <sub>3</sub>	L <sub>4</sub>	M <sub>1</sub> × depth
MLC 15	☆	43	107	16	4	8.5	32	25	3.5	32	—	17.8	36	M3×4
ML 15	☆	63								42	20	27.9	47	
MLG 15	☆	93								57	25	42.8	62	
MLC 20	☆	89	156	20	5	10	40	30	5	38	—	22.3	42	M4×6
ML 20	☆	130								50	25	34.6	55	
MLG 20	☆	189								68	30	52.3	72	
MLC 25	☆	189	243	25	5	12.5	48	35	6.5	55	—	31.9	65	M6×7
ML 25	☆	305								78	35	55.7	89	
MLG 25	☆	405								98	40	75.5	108	

Note(1): Track rail lengths L are shown in Table 8.1 on page A-8.

(2): The directions of basic dynamic load rating (C), basic static load rating (C<sub>0</sub>) and static moment rating (T<sub>0</sub>, T<sub>x</sub> and T<sub>y</sub>) are shown in the sketches below. The upper values in the T<sub>x</sub> and T<sub>y</sub> column apply to one slide unit, and the lower values apply to two units in close contact.

Remark 1: The mark ☆ indicates that it is also applicable to interchangeable specification.

2: The appended bolts for mounting track rails are stainless hexagon socket head bolts of JIS B1176 or equivalent, or stainless cross-recessed head cap screws for precision equipment.

3: For specification of grease nipple, see page 99.

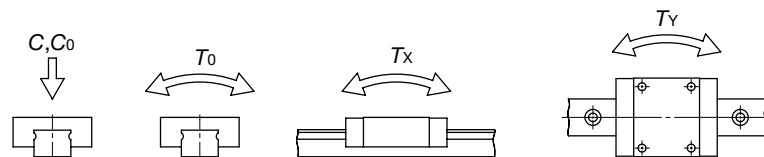

H <sub>3</sub>	Dimension of track rail mm							Appended mounting bolt for track rail mm Bolt size x length	Basic dynamic load rating <sup>(2)</sup>	Basic static load rating <sup>(2)</sup>	Static moment rating <sup>(2)</sup>		
	W	H <sub>4</sub>	d <sub>3</sub>	d <sub>4</sub>	h	E	F		C N	C <sub>0</sub> N	T <sub>0</sub> N·m	T <sub>x</sub> N·m	T <sub>y</sub> N·m
3.1	15	10	3.5	6.5	4.5	20	40	Hexagon socket head bolt M3×10	3 490	3 890	30.0	11.7	9.8
									4 980	6 490	50.0	29.7	24.9
									6 620	9 740	75.0	63.9	53.6
4.2	20	11	6	9.5	5.5	30	60	Hexagon socket head bolt M5×14	4 580	5 300	54.0	19.4	16.3
									6 650	9 080	92.6	52.7	44.2
									8 510	12 900	131	102	85.7
5	23	15	7	11.0	9.0	30	60	Hexagon socket head bolt M6×16	9 120	10 600	128	57.4	48.1
									13 500	18 500	223	163	137
									16 700	25 200	303	293	246

Example of identification number for assembled set (For details, see "Identification number and specification".)

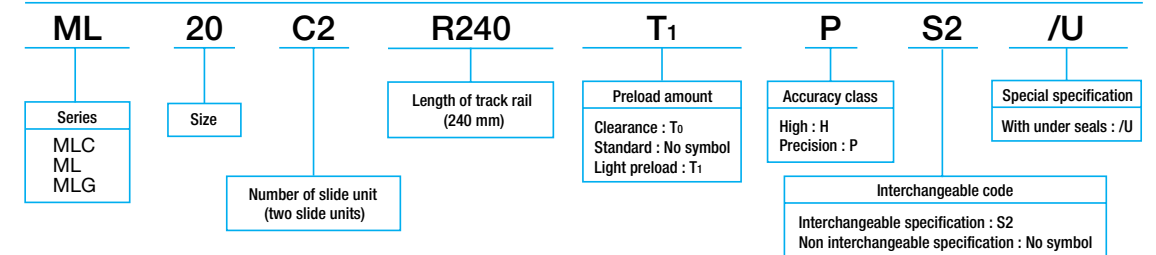

※In case ordering track rail only, model code is changed as shown below.  
Track rail of interchangeable ML → Model code LWL...B (Ex: LWL20R240BPS2)

MLFC  
MLF  
MLFG

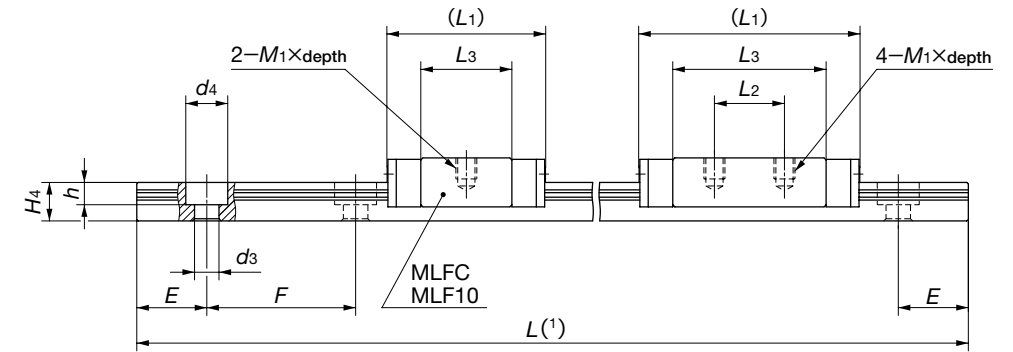
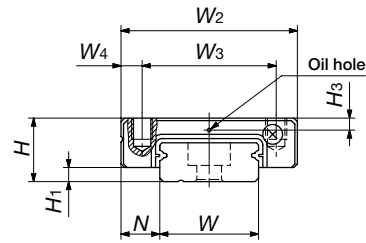

Model number	Interchangeable	Mass (Reference) g		Dimension of assembly mm			Dimension of slide unit mm							
		Slide unit	Track rail (per 100mm)	H	H <sub>1</sub>	N	W <sub>2</sub>	W <sub>3</sub>	W <sub>4</sub>	L <sub>1</sub>	L <sub>2</sub>	L <sub>3</sub>	M <sub>1</sub> × depth	H <sub>3</sub>
MLFC 10	☆	6.1	28	6.5	1.5	3.5	17	13	2	20.5	—	13.6	M2.5 × 1.5	1.3
MLF 10	☆	7.6								24.5		17.6		
MLFC 14	☆	13	54	9	2	5.5	25	19	3	22.5	10	13	M3 × 3	1.7
MLF 14	☆	20								31.5		22		
MLFG 14	☆	29								42		19		
MLFC 18	☆	26	90	12	3	6	30	21	4.5	26.5	12	16.6	M3 × 3	2.5
MLF 18	☆	42								39		28.6		
MLFG 18	☆	59								50.5		24		
MLFC 24	☆	46	139	14	3	8	40	28	6	30.5	15	17.7	M3 × 3.5	3.2
MLF 24	☆	74								44		31		
MLFG 24	☆	108								59		28		

Note(1) : Track rail lengths L are shown in Table 8.2 on page A-9.

(2) : The directions of basic dynamic load rating (C), basic static load rating (C<sub>0</sub>) and static moment rating (T<sub>0</sub>, T<sub>x</sub> and T<sub>y</sub>) are shown in the sketches below. The upper values in the T<sub>x</sub> and T<sub>y</sub> column apply to one slide unit, and the lower values apply to two units in close contact.

Remark 1 : The mark ☆ indicates that it is also applicable to interchangeable specification.

2 : The appended bolts for mounting track rails are stainless hexagon socket head bolts of JIS B1176 or equivalent, or stainless cross-recessed head cap screws for precision equipment.

3 : Oil hole is provided for MLF10 to MLF24 models.

4 : For specification of oil hole, see page 101.

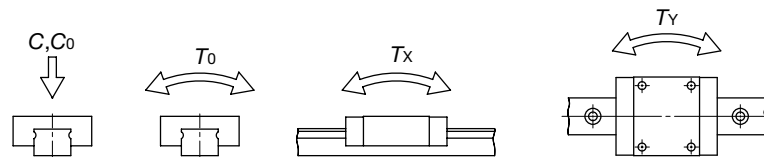

Dimension of track rail mm							Appended mounting bolt for track rail mm Bolt size x length	Basic dynamic load rating(2) C N	Basic static load rating(2) C <sub>0</sub> N	Static moment rating(2)		
W	H <sub>4</sub>	d <sub>3</sub>	d <sub>4</sub>	h	E	F				T <sub>0</sub> N·m	T <sub>x</sub> N·m	T <sub>y</sub> N·m
10	4	2.9	4.8	1.6	10	20	Cross-recessed head cap screw for precision equipment M2.5×7	712	1 180	6.1	2.6	2.2
								849	1 510	7.8	14.9	12.5
14	5.5	3.5	6	3.2	15	30	Hexagon socket head bolt M3×8	1 240	1 700	12.2	3.8	3.2
								1 770	2 840	20.3	24.6	20.7
								2 320	4 160	29.8	10.1	8.4
18	7	3.5	6.5	4.5	15	30	Hexagon socket head bolt M3×8	1 510	2 120	19.4	5.5	4.7
								2 280	3 810	34.9	35.9	30.1
								2 870	5 300	48.5	16.9	14.2
								2 870	5 300	48.5	90.1	75.6
24	8	4.5	8	4.5	20	40	Hexagon socket head bolt M4×10	2 800	3 340	40.7	31.9	26.7
								4 310	6 200	75.6	159	134
								5 620	9 060	111	9.7	8.2
								5 620	9 060	111	67.6	56.8

Example of identification number for assembled set (For details, see "Identification number and specification".)

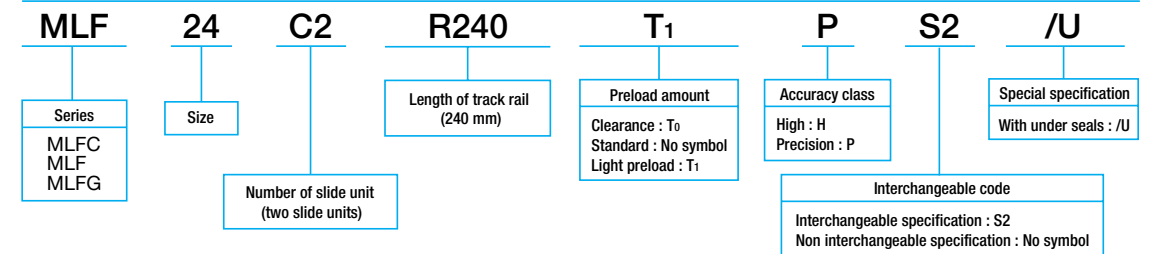

※In case ordering track rail only, model code is changed as shown below.  
Track rail of interchangeable MLF ⇒ Model code LWLF...B (Ex: LWLF14R240BPS2)

MLFC  
MLF  
MLFG

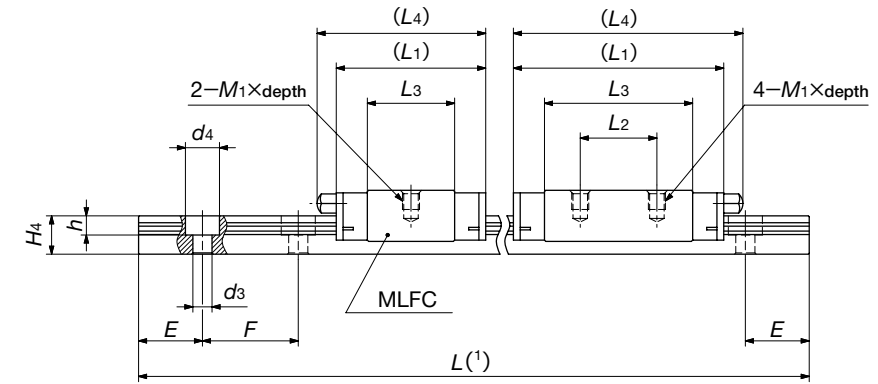
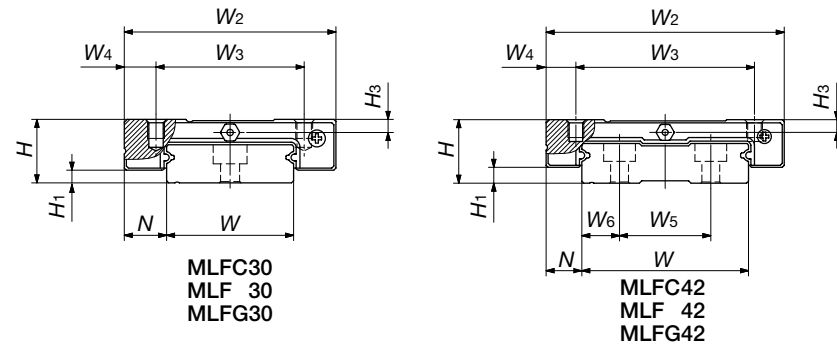

Model number	Interchangeable	Mass (Reference) g	Dimension of assembly mm		Dimension of slide unit mm										
			Slide unit	Track rail (per 100mm)	H	H <sub>1</sub>	N	W <sub>2</sub>	W <sub>3</sub>	W <sub>4</sub>	L <sub>1</sub>	L <sub>2</sub>	L <sub>3</sub>	L <sub>4</sub>	M <sub>1</sub> × depth
MLFC 30	☆	70	198	15	3	10	50	35	7.5	35.5	—	20.5	40	M4 × 4.5	3.1
MLF 30	☆	111								50	18	34.8	54		
MLFG 30	☆	167								68.5	35	53.8	73		
MLFC 42	☆	95	294	16	4	9	60	45	7.5	41.5	—	25.7	46	M4 × 4.5	3.2
MLF 42	☆	138								55	20	39.4	60		
MLFG 42	☆	200								74.5	35	58.7	79		

Dimension of track rail mm									Appended mounting bolt for track rail mm	Basic dynamic load rating <sup>(2)</sup> C	Basic static load rating <sup>(2)</sup> C <sub>0</sub>	Static moment rating <sup>(2)</sup>		
W	H <sub>4</sub>	W <sub>5</sub>	W <sub>6</sub>	d <sub>3</sub>	d <sub>4</sub>	h	E	F				Bolt size x length	T <sub>0</sub>	T <sub>x</sub>
										N	N	N·m	N·m	N·m
30	9	—	—	4.5	8	4.5	20	40	Hexagon socket head bolt M4 × 12	3 890	4 540	69.1	15.4	13.0
										5 970	8 440	128	48.7	40.8
										7 810	12 300	187	100	84.3
42	10	23	9.5	4.5	8	4.5	20	40	Hexagon socket head bolt M4 × 12	5 440	6 810	144	30.8	25.8
										7 050	9 840	209	61.3	51.4
										9 520	15 100	321	140	117

Note(1) : Track rail lengths L are shown in Table 8.2 on page A-9.

(2) : The directions of basic dynamic load rating (C), basic static load rating (C<sub>0</sub>) and static moment rating (T<sub>0</sub>, T<sub>x</sub> and T<sub>y</sub>) are shown in the sketches below. The upper values in the T<sub>x</sub> and T<sub>y</sub> column apply to one slide unit, and the lower values apply to two units in close contact.

Remark 1 : The mark ☆ indicates that it is also applicable to interchangeable specification.

2 : The appended bolts for mounting track rails are stainless hexagon socket head bolts of JIS B1176 or equivalent, or stainless cross-recessed head cap screws for precision equipment.

3 : For specification of grease nipple, see page 99.

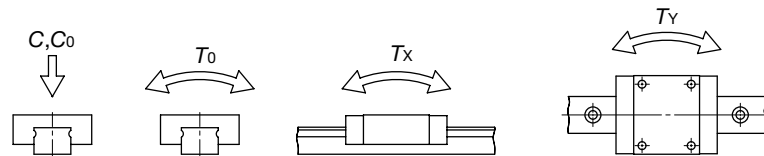

Example of identification number for assembled set (For details, see "Identification number and specification".)

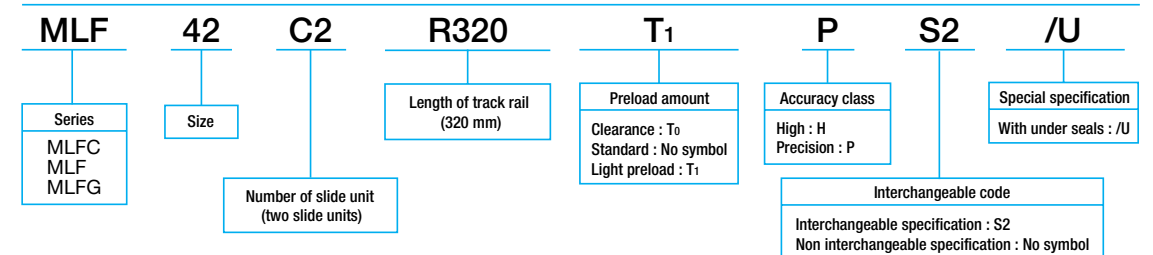

※ In case ordering track rail only, model code is changed as shown below.  
Track rail of interchangeable MLF → Model code LWLF...B (Ex: LWLF42R320BPS2)

# C-Lube Linear Way ME

ME/MET/MES

**IKO C-Lube Linear Way ME** is a linear motion rolling guide, incorporating the C-Lube as a components part for lubrication in the slide unit of compact type Linear Way E series to achieve maintenance free operations for a long period of time.

## Long-term maintenance free

The lubricant in the C-Lube keeps the lubrication performance for a long period of time and achieves long-term maintenance free operations. (5 years and 20,000km)  
So man-hours for troublesome lubrication control can be reduced.

## Lightweight and compact

The C-Sleeve is incorporated in the lightweight and compact slide unit of miniature type Linear Way E series without changing the external dimensions of the slide unit.

## Smooth and light motion

As the C-Lube is not in contact with the track rail, frictional resistance does not increase. A smooth and light motion is ensured.

## Various lengths of slide unit

In addition to the standard slide unit, a short type slide unit and a high rigidity long type slide unit both having the same sectional dimensions with the standard slide unit are available.

## Flange type and block type

Slide units are available in three different sectional shapes; two flange types for different mounting directions and one block type with a narrow width.

## Interchangeability

The track rails and the slide units of interchangeable specification can be handled separately and can be assembled to make a set as required. Three types of slide units with different lengths are prepared. The best type and size can be selected these entire slide units can be freely assembled on the same track rail.

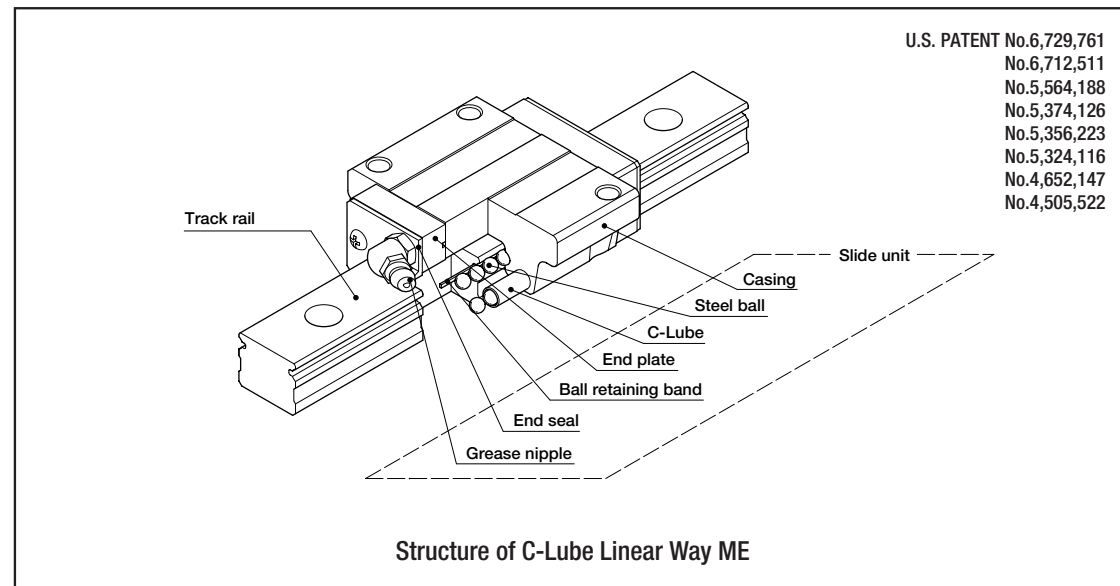

## Variation of IKO C-Lube Linear Way ME

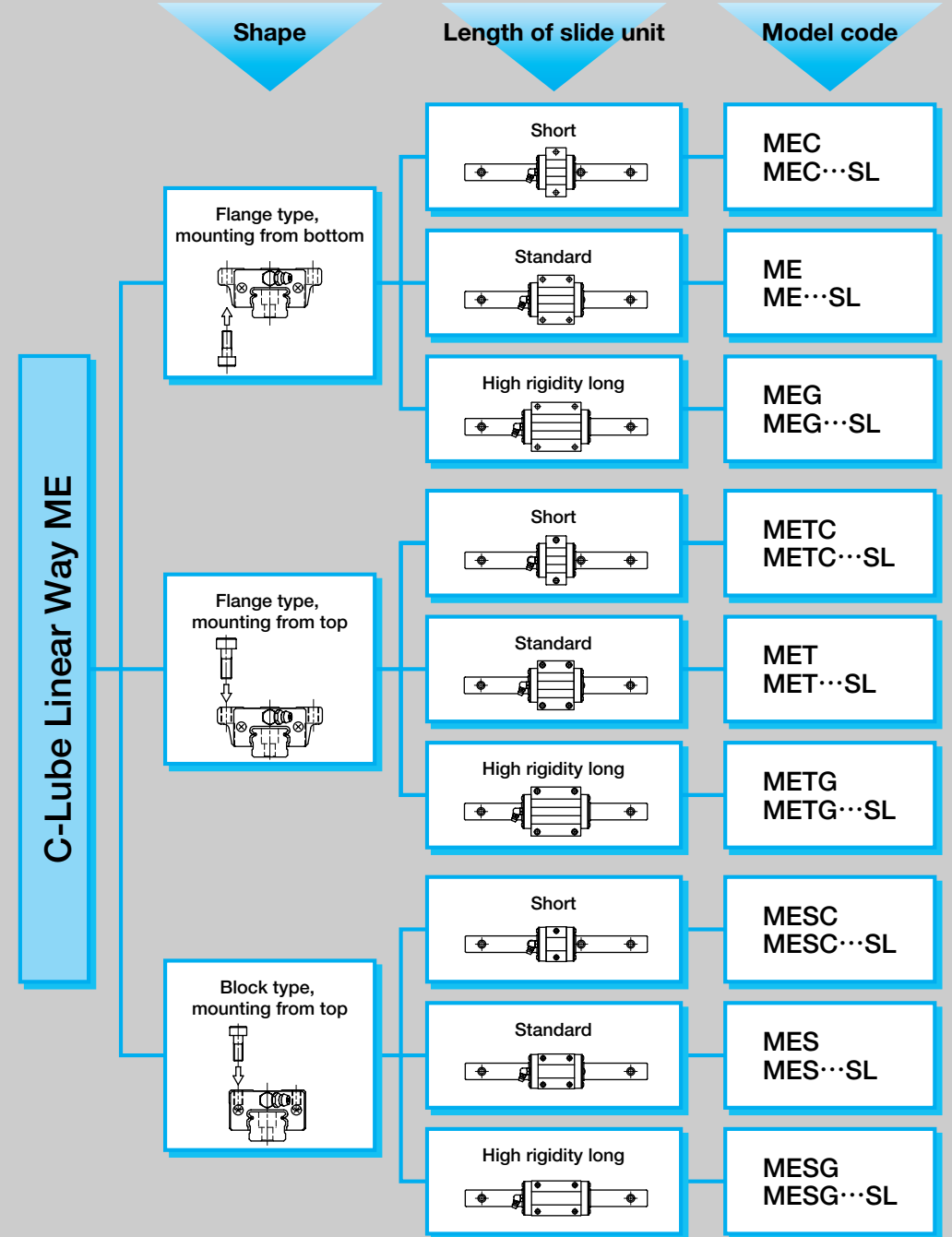

## Identification number and specification

The specification of C-Lube Linear Way ME is indicated by the identification number, consisting of a model code, a size, a part code, a preload symbol, a classification symbol and any supplemental codes. For details of each specification, see page 78.

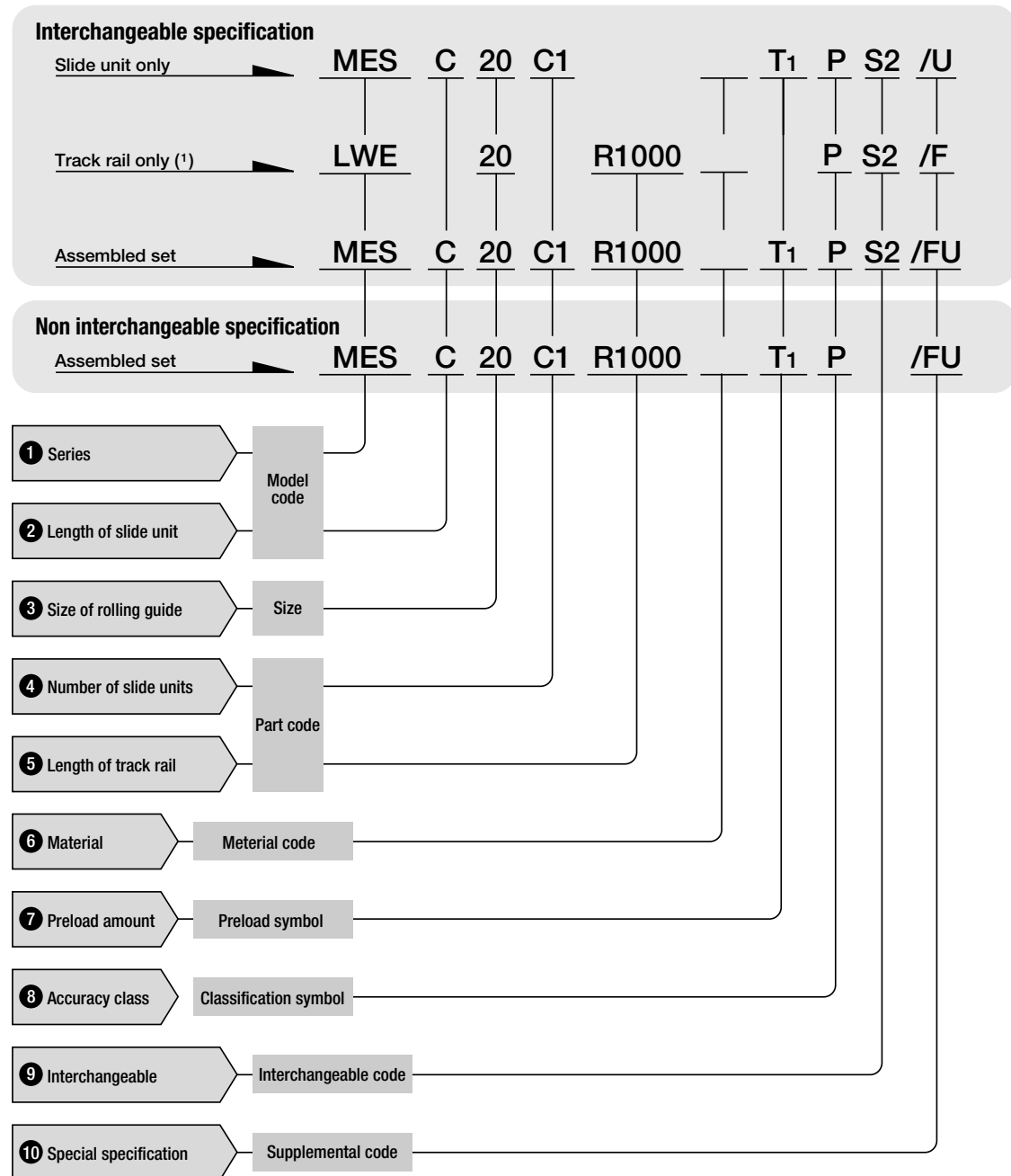

Note(\*): In case ordering track rail only, model code should be changed as shown below.  
Track rail of interchangeable ME → Model code LWE (Ex: LWE15R1000PS2)

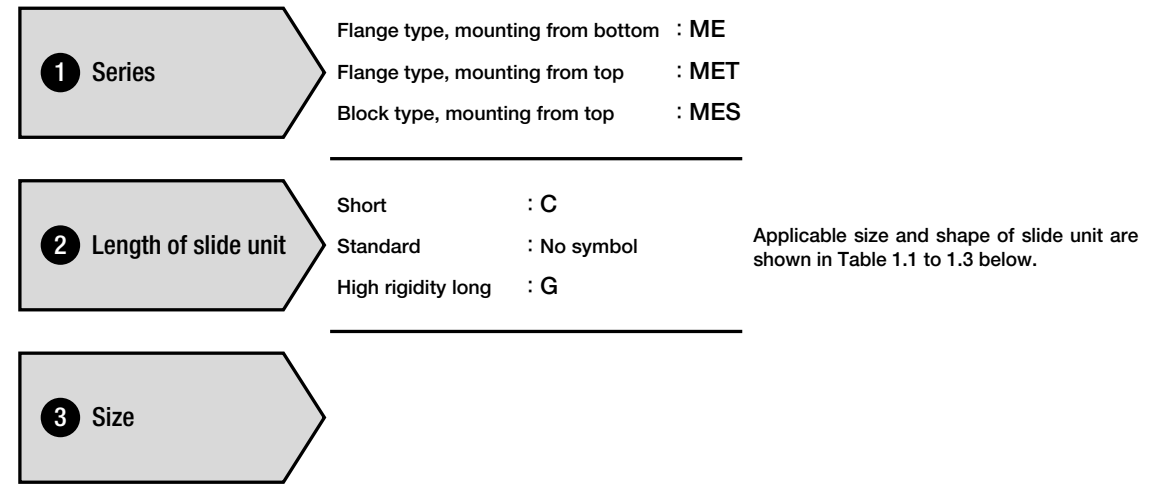

Type and size of C-Lube Linear Way ME

Table 1.1 Flange type, mounting from bottom

Size	Type	Carbon steel			Stainless steel		
		Short MEC	Standard ME	High rigidity long MEG	Short MEC···SL	Standard ME···SL	High rigidity long MEG···SL
15		☆	☆	☆	☆	☆	☆
20		☆	☆	☆	☆	☆	☆
25		☆	☆	☆	☆	☆	☆
30		☆	☆	☆	☆	☆	☆
35		☆	☆	—	—	—	—
45		—	☆	—	—	—	—

Table 1.2 Flange type, mounting from top

Size	Type	Carbon steel			Stainless steel		
		Short METC	Standard MET	High rigidity long METG	Short METC···SL	Standard MET···SL	High rigidity long METG···SL
15		☆	☆	☆	☆	☆	☆
20		☆	☆	☆	☆	☆	☆
25		☆	☆	☆	☆	☆	☆
30		☆	☆	☆	☆	☆	☆
35		☆	☆	—	—	—	—
45		—	☆	—	—	—	—

Table 1.3 Block type, mounting from top

Size	Type	Carbon steel			Stainless steel		
		Short MESC	Standard MES	High rigidity long MESG	Short MESC···SL	Standard MES···SL	High rigidity long MESG···SL
15		☆	☆	☆	☆	☆	☆
20		☆	☆	☆	☆	☆	☆
25		☆	☆	☆	☆	☆	☆
30		☆	☆	☆	☆	☆	☆
35		☆	☆	—	—	—	—
45		—	☆	—	—	—	—

Remark : ☆ marks indicates that interchangeable products are available.

**4** Number of slide unit

Assembled set : C○  
Slide unit only : C1  
For an assembled set, indicate the number of slide units assembled on one track rail. For an interchangeable slide unit only, "C1" can be indicated.

**5** Length of track rail

Assembled set : R○  
Track rail only : R○  
Indicate the length of track rail in mm. For standard and maximum lengths, see "Track rail length" on page A-27.

**6** Material

Stainless steel : SL  
Specify this items for an assembled set or an interchangeable track rail of C-Lube Linear Way ME size 15 to 30.

**7** Preload amount

Clearance : Tc  
Standard : No symbol  
Light preload : T1  
Medium preload : T2  
Specify this items for an assembled set or an interchangeable single slide unit. Applicable preload and size are shown in Table 3. For detail of preload amount, see page 86.

**8** Accuracy class

Ordinary : No symbol  
High class : H  
Precision class : P  
Super precision : SP  
In interchangeable specification, please combine same accuracy codes on both slide unit and track rail. For combination of accuracy and preload, see Table 2. Detail of accuracy is shown in page 81.

Table 2 Combination of accuracy and preload

Accuracy class and symbol	Ordinary class (No symbol)	High class (H)	Precision class (P)	Super precision class (SP)
Clearance (Tc)	☆	—	—	—
Standard (No symbol)	☆	☆	☆	○
Light preload (T1)	—	☆	☆	○
Medium preload (T2)	—	○	○	○

Remark : The mark ☆ indicates that it is also applicable to interchangeable specification.

**9** Interchangeable

Interchangeable : S2  
Specify this item for the interchangeable specification products. Assemble track rails and slide units with the same interchangeable code.

**10** Special specifications

Applicable special specifications are shown in Table 3. When a combination of several special specifications is required, please refer Table 4 and arrange their supplemental codes in alphabetical order. For detail of specifications are show on page 88.

Table 3 Applicable specifications

Specifications	Supplemental code	Set product	Track rail only	Slide unit only	Dimension
Butt jointing track rail	A	○	—	—	
Opposite reference surfaces arrangement	D	☆	—	—	
Specified rail mounting hole positions	E	☆	☆	—	
Caps for rail mounting holes	F	☆	☆	—	
Appending inspection sheet	I	○	—	—	
Female threads for bellows	J	☆	☆	☆	See table 5
Black chrome surface treatment	L	☆	—	—	
Fluoric black chrome surface treatment	LF	☆	—	—	
With track rail mounting bolts	MA	☆	☆	—	See table 6
Change of mounting hole size	M4	☆ (1)	☆ (1)	—	See table 7
No rubber end seals	N	☆	—	☆	
Butt jointing interchangeable track rail	T	☆ (2)	☆	—	
Under seals	U	☆	—	☆	See table 8
Double end seals	V	☆	—	☆	See table 9
Matched sets to be used as an assembled group	W	○	—	—	
Scrapers	Z	☆	—	☆	See table 10

Note(1) : Applicable to size 15

(2) : Not applicable to non interchangeable specification

Remark : The mark ☆ indicates that it is also applicable to interchangeable specification.

Table 4 Combination of special specifications

D	○																				
E	—	—																			
F	○	☆	☆																		
I	○	○	○	○																	
J	○	☆	☆	☆	○																
L	○	☆	☆	☆	○	☆															
LF	○	☆	☆	☆	○	☆	—														
MA	○	☆	☆	☆	○	☆	☆	☆													
M4	○	☆	☆	☆	○	☆	☆	☆	☆												
N	○	☆	☆	—	○	—	☆	☆	☆	☆											
T	—	☆	☆	☆	—	—	☆	☆	☆	☆	☆										
U	○	☆	☆	☆	○	☆	☆	☆	☆	☆	—	☆									
V	○	☆	☆	☆	○	★	☆	☆	☆	☆	—	☆	☆								
W	○	○	—	○	○	○	○	○	○	○	○	—	○	○							
Z	○	☆	☆	☆	○	★	☆	☆	☆	☆	—	☆	☆	★	○						
	A	D	E	F	I	J	L	LF	MA	M4	N	T	U	V	W						

Remark 1 : In the table, the mark ○ indicates that this combination can be made.  
2 : The mark ☆ indicates that the combination is available for also interchangeable specification.  
3 : When the specification with ★ is required, please consult I I K O.  
4 : When a combination of several specifications is required, arrange their supplemental codes in alphabetical order.

Table 5 Female threads for bellows for ME series (Supplemental code /JJ)

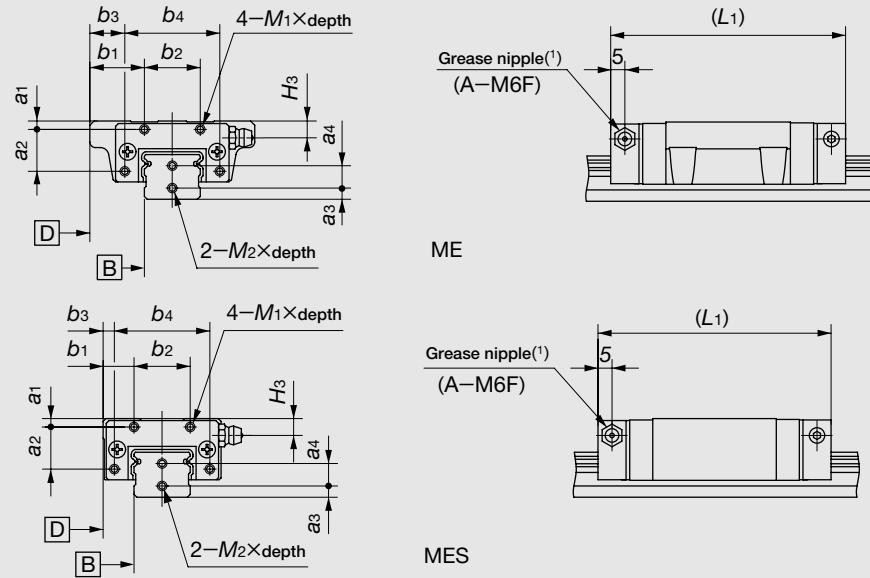

Model number	Slide unit								Track rail			
	a1	a2	b1	b2	b3	b4	M1×depth	L1 <sup>(2)</sup>	H3	a3	a4	M2×depth
ME (T) C 15 <sup>(1)</sup>	3	12	18	16	12	28	M3×6	58	5.7	4	7	M3× 6
ME (T) 15 <sup>(1)</sup>								74				
ME (T) G 15 <sup>(1)</sup>								87				
MESC 15 <sup>(1)</sup>								58				
MES 15 <sup>(1)</sup>								74				
MESG 15 <sup>(1)</sup>	87											
ME (T) C 20	3	15	19.5	20	12.5	34	M3×6	64	6	4	8	M3× 6
ME (T) 20								83				
ME (T) G 20								99				
MESC 20								64				
MES 20								83				
MESG 20	99											
ME (T) C 25	3.5	17	23.5	26	16.5	40	M3×6	76	7	5	9	M4× 8
ME (T) 25								100				
ME (T) G 25								119				
MESC 25								76				
MES 25								100				
MESG 25	119											
ME (T) C 30	5	17	28	34	20	50	M3×6	83	11	6	14	M4× 8
ME (T) 30								112				
ME (T) G 30								144				
MESC 30								83				
MES 30								112				
MESG 30	144											
ME (T) C 35	6	20	30	40	20	60	M3×6	93	13	7	15	M4× 8
ME (T) 35								126				
MESC 35								93				
MES 35								126				
MESG 35								126				
ME (T) 45	7	26	35	50	23	74	M4×8	138	15	8	19	M5×10
MES 45												

Note<sup>(1)</sup> : The specification and mounting positions of grease nipple are different from those of the standard specification product. Size 15 models are provided with a special specification grease nipple (NPB2 type). For detail of dimensions, consult IJKO for further information.

<sup>(2)</sup> : The values are for the slide unit with female threads for bellows at both ends.

Remark 1 : The table shows representative model numbers but is applicable to all models of the same size.

Table 6 Appended bolts size for mounting track rail (Supplemental code /MA)

Model number	Bolt size
ME 15	M 3×16 M 4×16 <sup>(1)</sup>
ME 20	M 5×16
ME 25	M 6×20
ME 30	M 6×25
ME 35	M 8×30
ME 45	M10×35

Note<sup>(1)</sup> : Applicable to track rail with supplemental code "/M4".

Remark 1 : The table shows representative model numbers but is applicable to all models of the same size.  
2 : Hexagon socket bolts of JIS B 1176 strength division 12.9 are appended.

Table 7 Changed size of mounting holes (Supplemental code /M4) for size 15

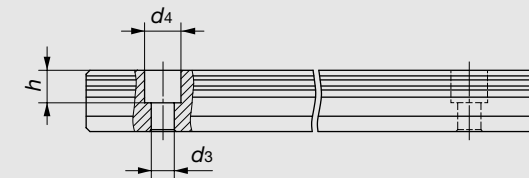

Model number	d3	d4	h
ME 15	4.5	8	6

Remark : The table shows representative model number but is applicable to all model of the same size.

Table 8 H<sub>1</sub> dimension of slide unit with under seals (Supplemental code /U)

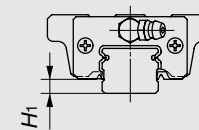

Model number	H <sub>1</sub>
ME 15	5
ME 20	5
ME 25	6
ME 30	7
ME 35	8
ME 45	10

Remark : The table shows representative model numbers but is applicable to all models of the same size.

Table 9 Slide unit with double end seals (Supplemental code /V, /VV)

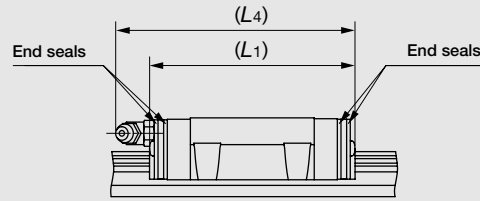

unit : mm

Model number	L1	L4	Model number	L1	L4
MEC 15	48	50	MEC 30	78	89
ME 15	64	66	ME 30	107	118
MEG 15	76	78	MEG 30	138	150
MEC 20	54	68	MEC 35	88	101
ME 20	73	87	ME 35	121	134
MEG 20	89	103	ME 45	137	148
MEC 25	67	80			
ME 25	91	104			
MEG 25	110	123			

Remark 1 : The table shows representative model numbers but is applicable to all models of the same size.  
 2 : The total lengths of slide unit with double end seals at both ends are shown.

Table 10 Slide unit with scrapers (Supplemental code /Z, /ZZ)

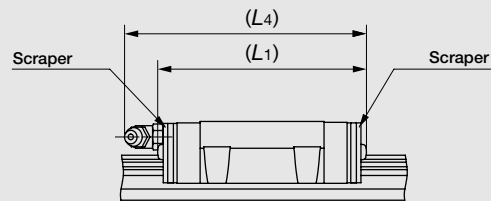

unit : mm

Model number	L1	L4	Model number	L1	L4
MEC 15	48	50	MEC 30	79	90
ME 15	64	66	ME 30	108	119
MEG 15	77	79	MEG 30	140	151
MEC 20	55	69	MEC 35	89	101
ME 20	75	88	ME 35	122	134
MEG 20	90	104	ME 45	138	148
MEC 25	69	81			
ME 25	93	105			
MEG 25	112	124			

Remark 1 : The table shows representative model numbers but is applicable to all models of the same size.  
 2 : The total lengths of slide unit with scrapers at both ends are shown.

## Track rail length

Standard and maximum lengths of track rail are shown in Table 11.

Track rail in any lengths are also available. Simply indicate the necessary length of track rail in millimeter (mm) in the identification number.

- In non-interchangeable specification, for track rail longer than the maximum length shown in Table 11, butt-jointing track rails are available upon request. In this case, indicate supplemental code "/A" in the identification number.
- E dimensions at both ends are the same unless otherwise specified. To change these dimensions, specify the specified rail mounting hole positions (supplemental code "/E") of special specification. For detail, see page 91.

Table 11 C-Lube Linear Way ME Standard and maximum lengths of track rails

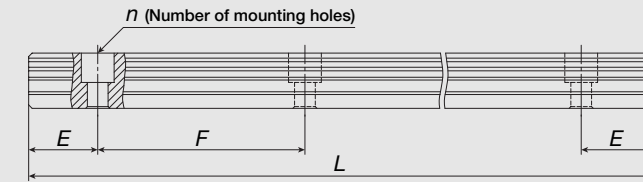

unit : mm

Item	Model number	ME 15	ME 20	ME 25	ME 30	ME 35	ME 45	ME15...SL	ME20...SL	ME25...SL	ME30...SL
Standard length L (n)		160 ( 3)	220 ( 4)	220 ( 4)	280 ( 4)	280 ( 4)	570 ( 6)	160 ( 3)	220 ( 4)	220 ( 4)	280 ( 4)
		220 ( 4)	280 ( 5)	280 ( 5)	440 ( 6)	440 ( 6)	885 ( 9)	220 ( 4)	280 ( 5)	280 ( 5)	440 ( 6)
		280 ( 5)	340 ( 6)	340 ( 6)	600 ( 8)	600 ( 8)	1 200 (12)	280 ( 5)	340 ( 6)	340 ( 6)	600 ( 8)
		340 ( 6)	460 ( 8)	460 ( 8)	760 (10)	760 (10)	1 620 (16)	340 ( 6)	460 ( 8)	460 ( 8)	760 (10)
		460 ( 8)	640 (11)	640 (11)	1 000 (13)	1 000 (13)	2 040 (20)	460 ( 8)	640 (11)	640 (11)	1 000 (13)
		640 (11)	820 (14)	820 (14)	1 240 (16)	1 240 (16)	2 460 (24)	640 (11)	820 (14)	820 (14)	
		820 (14)	1 000 (17)	1 000 (17)	1 640 (21)	1 640 (21)	2 985 (29)	820 (14)	1 000 (17)	1 000 (17)	
			1 240 (21)	1 240 (21)	2 040 (26)	2 040 (26)					
Mounting hole pitch F		60	60	60	80	80	105	60	60	60	80
E (1)		20	20	20	20	20	22.5	20	20	20	20
Reference dimension E (2)	Over (Incl.)	6	8	9	9	10	12	6	8	9	9
	Under	36	38	39	49	50	64.5	36	38	39	49
Maximum length (3)(4)		1 600	2 200	2 980	3 000	3 000	2 985	1 200	1 200	1 200	1 200
		(2 980)	(2 980)	(4 000)	(3 960)	(3 960)	(3 930)	(1 600)	(1 960)	(1 960)	(1 960)

Note(1) : When specifying a butt-jointing interchangeable track rail (supplemental code "/T"), pay attention to the E dimension at the butt-jointing part.  
 (2) : Not applicable to the track rail with female threads for bellows (Supplemental code /J).  
 (3) : The dimension "E" of stainless steel product is the half value of dimension "F".  
 (4) : The track rails can be manufactured up to the maximum length shown in parentheses. If required, please consult for further IJKO information.  
 Remark : The table shows representative model numbers but is also applicable to all the models in the same size.



Flange type, mounting from bottom

MEC  
ME  
MEG

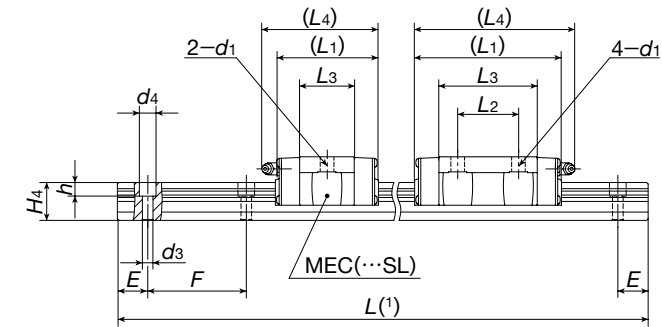
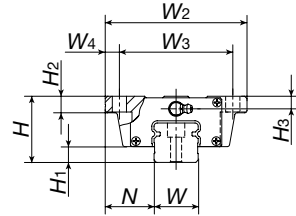

Model number	Interchangeable	Mass (Reference)		Dimension of assembly mm			Dimension of slide unit mm									
		Slide unit kg	Track rail kg/m	H	H <sub>1</sub>	N	W <sub>2</sub>	W <sub>3</sub>	W <sub>4</sub>	L <sub>1</sub>	L <sub>2</sub>	L <sub>3</sub>	L <sub>4</sub>	d <sub>1</sub>	H <sub>2</sub>	H <sub>3</sub>
MEC 15	☆	0.11	1.57	24	5.8	18.5	52	41	5.5	41	—	22.4	45	4.5	7	4.5
MEC 15···SL	☆									57	26	38.4	61			
ME 15	☆	0.18	2.28	28	6	19.5	59	49	5	57	26	38.4	61	5.5	9	5.5
ME 15···SL	☆									66.5	32	44.2	79			
MEG 15	☆	0.24	3.09	33	7	25	73	60	6.5	70	36	51.1	74	7	10	6.5
MEG 15···SL	☆									82	45	60.1	95			
MEC 20	☆	0.18	2.28	28	6	19.5	59	49	5	47	—	24.7	59	5.5	9	5.5
MEC 20···SL	☆									66.5	32	44.2	79			
ME 20	☆	0.30	3.09	33	7	25	73	60	6.5	82	45	60.1	95	5.5	9	5.5
ME 20···SL	☆									82	45	60.1	95			
MEG 20	☆	0.39	3.09	33	7	25	73	60	6.5	82	45	60.1	95	7	10	6.5
MEG 20···SL	☆									82	45	60.1	95			
MEC 25	☆	0.33	3.09	33	7	25	73	60	6.5	59	—	32	71	7	10	6.5
MEC 25···SL	☆									83	35	56	95			
ME 25	☆	0.54	3.09	33	7	25	73	60	6.5	83	35	56	95	7	10	6.5
ME 25···SL	☆									83	35	56	95			
MEG 25	☆	0.72	3.09	33	7	25	73	60	6.5	102	50	75	114	7	10	6.5
MEG 25···SL	☆									102	50	75	114			

Dimension of track rail mm							Recommended mounting bolt for track rail <sup>(2)</sup> mm Bolt size x length	Basic dynamic load rating <sup>(3)</sup> C N	Basic static load rating <sup>(3)</sup> C <sub>0</sub> N	Static moment rating <sup>(3)</sup>		
W	H <sub>4</sub>	d <sub>3</sub>	d <sub>4</sub>	h	E	F				T <sub>0</sub> N·m	T <sub>X</sub> N·m	T <sub>Y</sub> N·m
15	14.5	3.6 (4.5)	6.5 (8)	4.5 (6)	20	60	M3×16 (M4×16)	5 240	5 480	43.8	21.3 149	21.3 149
								7 640	9 390	75.1	57.6 333	57.6 333
								9 340	12 500	100	99.5 533	99.5 533
20	16	6	9.5	8.5	20	60	M5×16	7 580	7 340	78.9	31.5 235	31.5 235
								11 600	13 400	145	95.6 561	95.6 561
								14 400	18 300	197	172 918	172 918
23	19	7	11	9	20	60	M6×20	12 400	12 300	153	71.8 480	71.8 480
								18 100	21 100	262	195 1 090	195 1 090
								22 200	28 200	349	336 1 740	336 1 740

Note<sup>(1)</sup>: Track rail lengths L are shown in Table 11 on page A-27.

<sup>(2)</sup>: Track rail mounting bolts are not appended. Hexagon socket bolts of JIS B 1176 strength division 12.9 or equivalent are recommended.

Values in parentheses are applicable to the track rail of supplemental code "/M4" of special specification.

<sup>(3)</sup>: The directions of basic dynamic load rating (C), basic static load rating (C<sub>0</sub>) and static moment rating (T<sub>0</sub>, T<sub>X</sub> and T<sub>Y</sub>) are shown in the sketches below. The upper values in the T<sub>X</sub> and T<sub>Y</sub> column apply to one slide unit, and the lower values apply to two units in close contact.

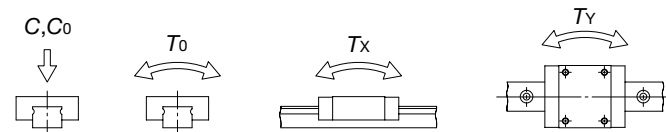

Example of identification number of assembled set (For details, see "Identification number and specification".)

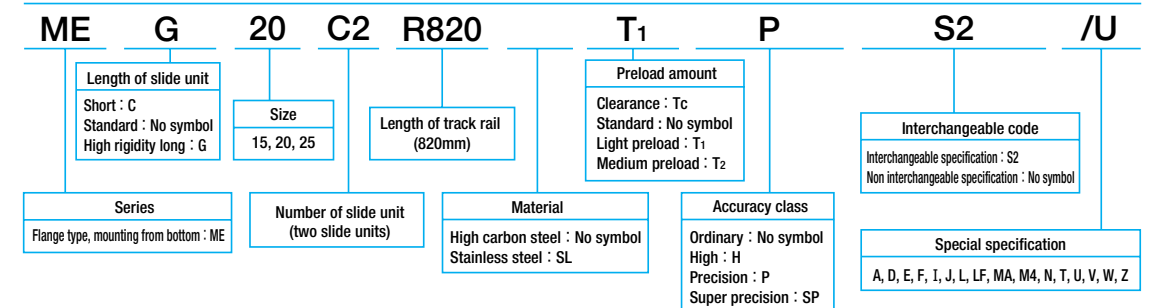

※ In case ordering track rail only, model code is changed as shown below.  
Track rail of interchangeable ME → Model code LW (Ex: LWE20R820PS2)

Flange type, mounting from bottom  
**MEC**  
**ME**  
**MEG**

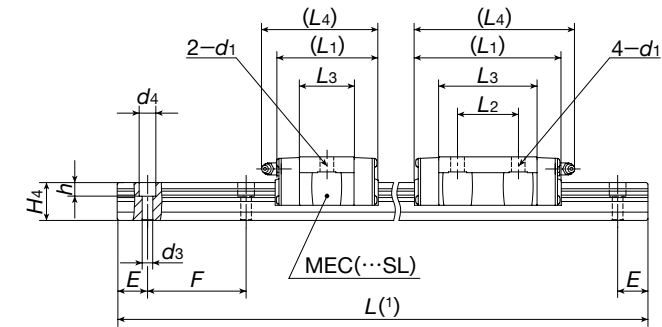
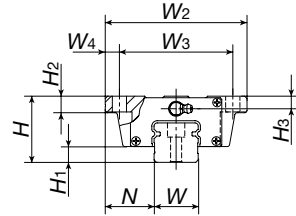

Model number	Interchangeable	Mass (Reference)		Dimension of assembly mm			Dimension of slide unit mm									
		Slide unit kg	Track rail kg/m	H	H <sub>1</sub>	N	W <sub>2</sub>	W <sub>3</sub>	W <sub>4</sub>	L <sub>1</sub>	L <sub>2</sub>	L <sub>3</sub>	L <sub>4</sub>	d <sub>1</sub>	H <sub>2</sub>	H <sub>3</sub>
<b>MEC 30</b>	☆	0.58	5.09	42	10	31	90	72	9	68	—	36	78	9	10	8
<b>MEC 30···SL</b>	☆									97	40	64.8	107			
<b>ME 30</b>	☆	0.99	5.09	42	10	31	90	72	9	97	40	64.8	107	9	10	8
<b>ME 30···SL</b>	☆									128.5	60	96.5	139			
<b>MEG 30</b>	☆	1.50	5.09	42	10	31	90	72	9	128.5	60	96.5	139	9	10	8
<b>MEG 30···SL</b>	☆									128.5	60	96.5	139			
<b>MEC 35</b>	☆	0.84	6.85	48	11	33	100	82	9	78	—	41.6	90	9	13	10
<b>ME 35</b>	☆									111	50	74.6	123			
<b>ME 45</b>	☆	2.46	11.2	60	14	37.5	120	100	10	125	60	81.4	136	11	15	13

Dimension of track rail mm							Recommended mounting bolt for track rail <sup>(2)</sup> mm Bolt size x length	Basic dynamic load rating <sup>(3)</sup> C N	Basic static load rating <sup>(3)</sup> C <sub>0</sub> N	Static moment rating <sup>(3)</sup>		
W	H <sub>4</sub>	d <sub>3</sub>	d <sub>4</sub>	h	E	F				T <sub>0</sub> N·m	T <sub>X</sub> N·m	T <sub>Y</sub> N·m
28	25	7	11	9	20	80	M 6×25	20 600	18 800	287	129 855	129 855
								29 500	31 300	479	328 1 920	328 1 920
								39 200	47 000	718	704 3 670	704 3 670
34	28	9	14	12	20	80	M 8×30	29 900	26 800	412	176 1 190	162 1 100
								42 900	44 700	686	448 2 660	412 2 450
45	34	11	17.5	14	22.5	105	M10×35	61 100	60 200	1 210	672 4 070	618 3 750

Note<sup>(1)</sup>: Track rail lengths L are shown in Table 11 on page A-27.  
<sup>(2)</sup>: Track rail mounting bolts are not appended. Hexagon socket bolts of JIS B 1176 strength division 12.9 or equivalent are recommended.  
<sup>(3)</sup>: The directions of basic dynamic load rating (C), basic static load rating (C<sub>0</sub>) and static moment rating (T<sub>0</sub>, T<sub>X</sub> and T<sub>Y</sub>) are shown in the sketches below. The upper values in the T<sub>X</sub> and T<sub>Y</sub> column apply to one slide unit, and the lower values apply to two units in close contact.

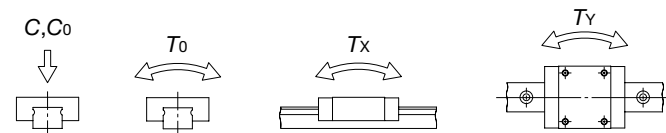

Example of identification number of assembled set (For details, see "Identification number and specification".)

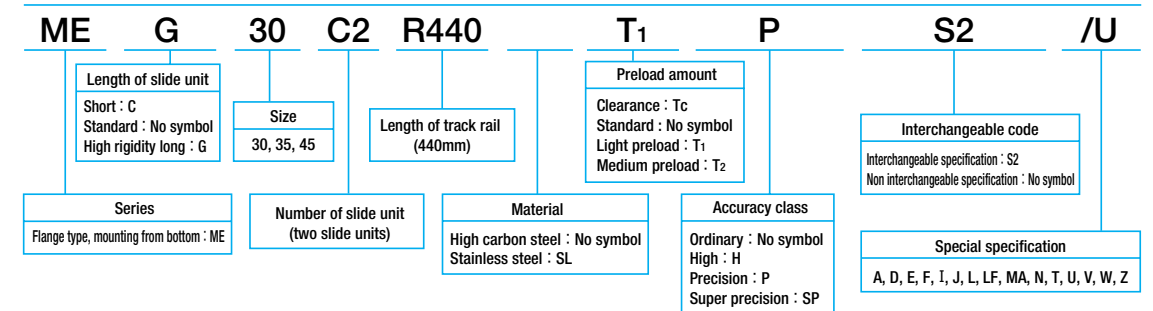

※ In case ordering track rail only, model code is changed as shown below.  
 Track rail of interchangeable ME → Model code LWE (Ex:LWE30R440PS2)

Flange type, mounting from top  
**METC**  
**MET**  
**METG**

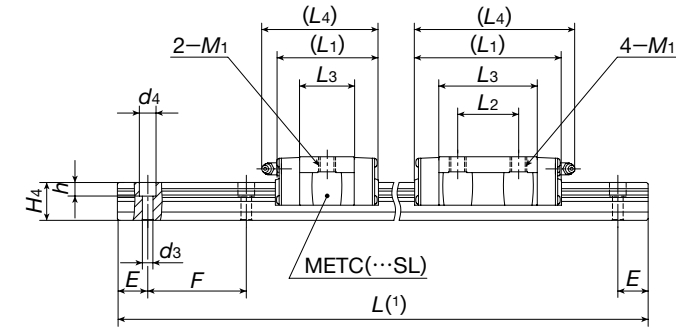
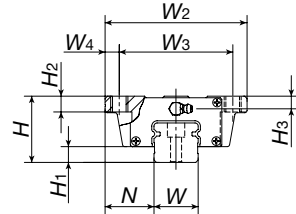

Model number	Interchangeable	Mass (Reference)		Dimension of assembly mm			Dimension of slide unit mm									
		Slide unit kg	Track rail kg/m	H	H <sub>1</sub>	N	W <sub>2</sub>	W <sub>3</sub>	W <sub>4</sub>	L <sub>1</sub>	L <sub>2</sub>	L <sub>3</sub>	L <sub>4</sub>	M <sub>1</sub>	H <sub>2</sub>	H <sub>3</sub>
METC 15	☆	0.11	1.57	24	5.8	18.5	52	41	5.5	41	—	22.4	45	M5	7	4.5
METC 15...SL	☆									57	26	38.4	61			
MET 15	☆	0.18	1.57	24	5.8	18.5	52	41	5.5	70	36	51.1	74	M5	7	4.5
MET 15...SL	☆									57	26	38.4	61			
METG 15	☆	0.24	1.57	24	5.8	18.5	52	41	5.5	70	36	51.1	74	M5	7	4.5
METG 15...SL	☆									57	26	38.4	61			
METC 20	☆	0.18	2.28	28	6	19.5	59	49	5	47	—	24.7	59	M6	9	5.5
METC 20...SL	☆									66.5	32	44.2	79			
MET 20	☆	0.30	2.28	28	6	19.5	59	49	5	82	45	60.1	95	M6	9	5.5
MET 20...SL	☆									66.5	32	44.2	79			
METG 20	☆	0.39	2.28	28	6	19.5	59	49	5	82	45	60.1	95	M6	9	5.5
METG 20...SL	☆									66.5	32	44.2	79			
METC 25	☆	0.33	3.09	33	7	25	73	60	6.5	59	—	32	71	M8	10	6.5
METC 25...SL	☆									83	35	56	95			
MET 25	☆	0.54	3.09	33	7	25	73	60	6.5	102	50	75	114	M8	10	6.5
MET 25...SL	☆									83	35	56	95			
METG 25	☆	0.72	3.09	33	7	25	73	60	6.5	102	50	75	114	M8	10	6.5
METG 25...SL	☆									83	35	56	95			

Dimension of track rail mm							Recommended mounting bolt for track rail <sup>(2)</sup> mm Bolt size x length	Basic dynamic load rating <sup>(3)</sup> C N	Basic static load rating <sup>(3)</sup> C <sub>0</sub> N	Static moment rating <sup>(3)</sup>		
W	H <sub>4</sub>	d <sub>3</sub>	d <sub>4</sub>	h	E	F				T <sub>0</sub> N·m	T <sub>x</sub> N·m	T <sub>y</sub> N·m
15	14.5	3.6 (4.5)	6.5 (8)	4.5 (6)	20	60	M3×16 (M4×16)	5 240	5 480	43.8	21.3 149	21.3 149
								7 640	9 390	75.1	57.6 333	57.6 333
								9 340	12 500	100	99.5 533	99.5 533
20	16	6	9.5	8.5	20	60	M5×16	7 580	7 340	78.9	31.5 235	31.5 235
								11 600	13 400	145	95.6 561	95.6 561
								14 400	18 300	197	172 918	172 918
23	19	7	11	9	20	60	M6×20	12 400	12 300	153	71.8 480	71.8 480
								18 100	21 100	262	195 1 090	195 1 090
								22 200	28 200	349	336 1 740	336 1 740

Note<sup>(1)</sup>: Track rail lengths L are shown in Table 11 on page A-27.  
<sup>(2)</sup>: Track rail mounting bolts are not appended. Hexagon socket bolts of JIS B 1176 strength division 12.9 or equivalent are recommended. Values in parentheses are applicable to the track rail of supplemental code "/M4" of special specification.  
<sup>(3)</sup>: The directions of basic dynamic load rating (C), basic static load rating (C<sub>0</sub>) and static moment rating (T<sub>0</sub>, T<sub>x</sub> and T<sub>y</sub>) are shown in the sketches below. The upper values in the T<sub>x</sub> and T<sub>y</sub> column apply to one slide unit, and the lower values apply to two units in close contact.

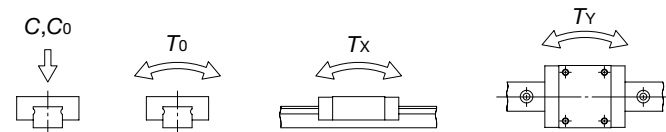

Example of identification number of assembled set (For details, see "Identification number and specification".)

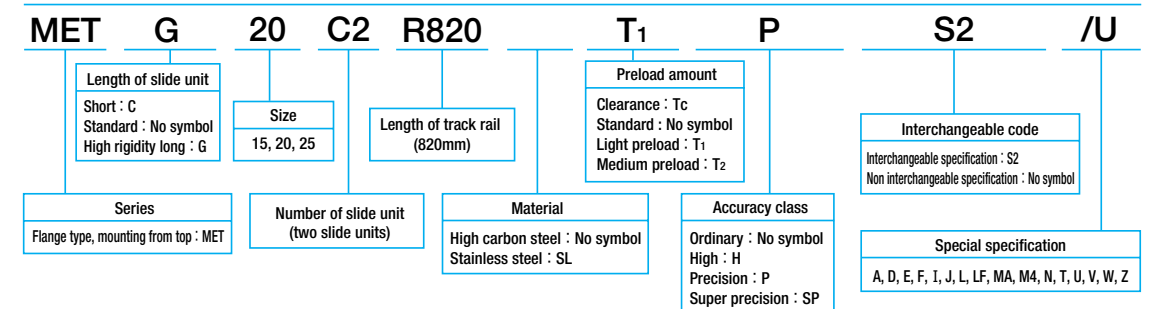

※ In case ordering track rail only, model code is changed as shown below.  
 Track rail of interchangeable ME → Model code LW (Ex: LWE20R820PS2)

Flange type, mounting from top  
**METC**  
**MET**  
**METG**

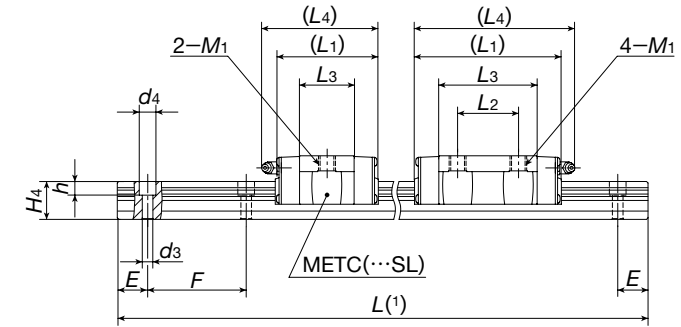
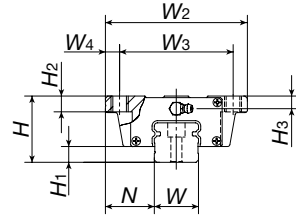

Model number	Interchangeable	Mass (Reference)		Dimension of assembly mm			Dimension of slide unit mm									
		Slide unit kg	Track rail kg/m	H	H <sub>1</sub>	N	W <sub>2</sub>	W <sub>3</sub>	W <sub>4</sub>	L <sub>1</sub>	L <sub>2</sub>	L <sub>3</sub>	L <sub>4</sub>	M <sub>1</sub>	H <sub>2</sub>	H <sub>3</sub>
<b>METC30</b>	☆	0.58	5.09	42	10	31	90	72	9	68	—	36	78	M10	10	8
<b>METC30...SL</b>	☆									97	40	64.8	107			
<b>MET 30</b>	☆	0.99	5.09	42	10	31	90	72	9	97	40	64.8	107	M10	10	8
<b>MET 30...SL</b>	☆									128.5	60	96.5	139			
<b>METG30</b>	☆	1.50	5.09	42	10	31	90	72	9	78	—	41.6	90	M10	13	10
<b>METG30...SL</b>	☆									111	50	74.6	123			
<b>METC35</b>	☆	0.84	6.85	48	11	33	100	82	9	78	—	41.6	90	M10	13	10
<b>MET 35</b>	☆	1.52								111	50	74.6	123			
<b>MET 45</b>	☆	2.46	11.2	60	14	37.5	120	100	10	125	60	81.4	136	M12	15	13

Note(1) : Track rail lengths L are shown in Table 11 on page A-27.  
 (2) : Track rail mounting bolts are not appended. Hexagon socket bolts of JIS B 1176 strength division 12.9 or equivalent are recommended.  
 (3) : The directions of basic dynamic load rating (C), basic static load rating (C<sub>0</sub>) and static moment rating (T<sub>0</sub>, T<sub>x</sub> and T<sub>y</sub>) are shown in the sketches below. The upper values in the T<sub>x</sub> and T<sub>y</sub> column apply to one slide unit, and the lower values apply to two units in close contact.

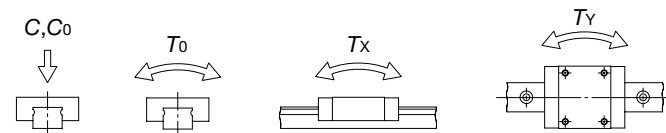

Dimension of track rail mm							Recommended mounting bolt for track rail(2) mm Bolt size x length	Basic dynamic load rating(3) C N	Basic static load rating(3) C <sub>0</sub> N	Static moment rating(3)		
W	H <sub>4</sub>	d <sub>3</sub>	d <sub>4</sub>	h	E	F				T <sub>0</sub> N·m	T <sub>x</sub> N·m	T <sub>y</sub> N·m
28	25	7	11	9	20	80	M 6×25	20 600	18 800	287	129 855	129 855
								29 500	31 300	479	328 1 920	328 1 920
								39 200	47 000	718	704 3 670	704 3 670
34	28	9	14	12	20	80	M 8×30	29 900	26 800	412	176 1 190	162 1 100
								42 900	44 700	686	448 2 660	412 2 450
45	34	11	17.5	14	22.5	105	M10×35	61 100	60 200	1 210	672 4 070	618 3 750

Example of identification number of assembled set (For details, see "Identification number and specification".)

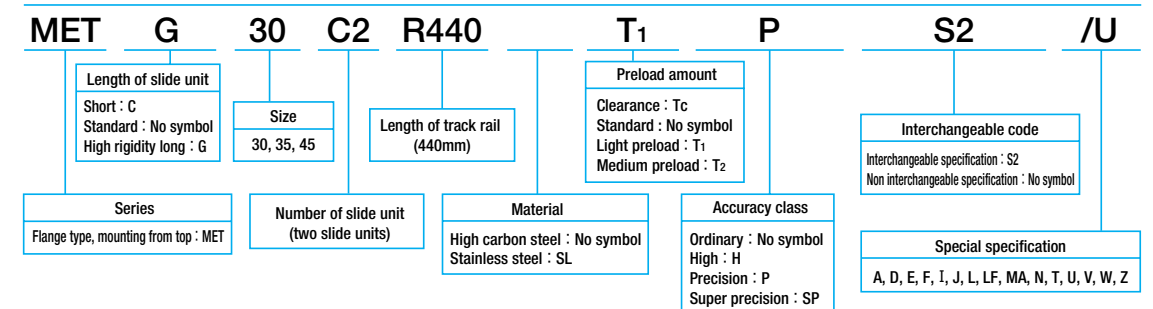

※ In case ordering track rail only, model code is changed as shown below.  
 Track rail of interchangeable ME → Model code LWE (Ex:LWE30R440PS2)

Block type, mounting from top  
**MESC**  
**MES**  
**MESG**

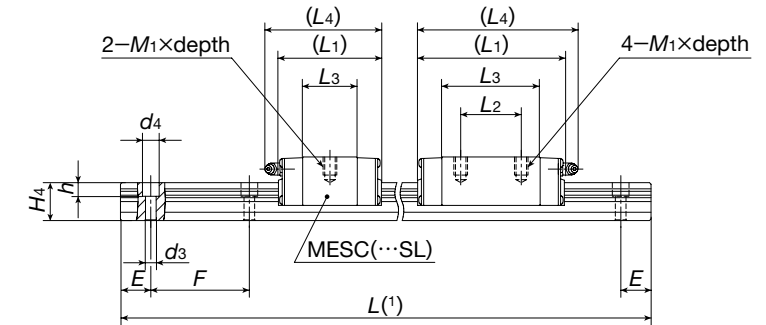
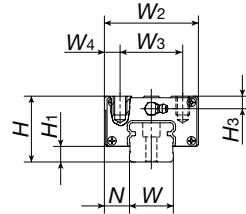

Model number	Interchangeable	Mass (Reference)		Dimension of assembly mm			Dimensions of slide unit mm							
		Slide unit kg	Track rail kg/m	H	H <sub>1</sub>	N	W <sub>2</sub>	W <sub>3</sub>	W <sub>4</sub>	L <sub>1</sub>	L <sub>2</sub>	L <sub>3</sub>	L <sub>4</sub>	M1×depth
MESC 15	☆	0.09	1.57	24	5.8	9.5	34	26	4	41	—	22.4	45	M4×7
MESC 15...SL	☆									57	26	38.4	61	
MES 15	☆	0.14	1.57	24	5.8	9.5	34	26	4	70	36	51.1	74	M4×7
MES 15...SL	☆									70	36	51.1	74	
MESG 15	☆	0.18	1.57	24	5.8	9.5	34	26	4	47	—	24.7	59	M5×8
MESG 15...SL	☆									47	—	24.7	59	
MESC 20	☆	0.15	2.28	28	6	11	42	32	5	66.5	32	44.2	79	M5×8
MESC 20...SL	☆									66.5	32	44.2	79	
MES 20	☆	0.25	2.28	28	6	11	42	32	5	82	45	60.1	95	M5×8
MES 20...SL	☆									82	45	60.1	95	
MESG 20	☆	0.32	2.28	28	6	11	42	32	5	59	—	32	71	M6×9
MESG 20...SL	☆									59	—	32	71	
MESC 25	☆	0.26	3.09	33	7	12.5	48	35	6.5	83	35	56	95	M6×9
MESC 25...SL	☆									83	35	56	95	
MES 25	☆	0.41	3.09	33	7	12.5	48	35	6.5	102	50	75	114	M6×9
MES 25...SL	☆									102	50	75	114	
MESG 25	☆	0.54	3.09	33	7	12.5	48	35	6.5	102	50	75	114	M6×9
MESG 25...SL	☆									102	50	75	114	

H <sub>3</sub>	Dimensions of track rail mm							Recommended mounting bolt for track rail <sup>(2)</sup> mm Bolt size x length	Basic dynamic load rating <sup>(3)</sup> C N	Basic static load rating <sup>(3)</sup> C <sub>0</sub> N	Static moment rating <sup>(3)</sup>		
	W	H <sub>4</sub>	d <sub>3</sub>	d <sub>4</sub>	h	E	F				T <sub>0</sub> N·m	T <sub>X</sub> N·m	T <sub>Y</sub> N·m
4.5	15	14.5	3.6 (4.5)	6.5 (8)	4.5 (6)	20	60	M3×16 (M4×16)	5 240	5 480	43.8	21.3 149	21.3 149
									7 640	9 390	75.1	57.6 333	57.6 333
									9 340	12 500	100	99.5 533	99.5 533
5.5	20	16	6	9.5	8.5	20	60	M5×16	7 580	7 340	78.9	31.5 235	31.5 235
									11 600	13 400	145	95.6 561	95.6 561
									14 400	18 300	197	172 918	172 918
6.5	23	19	7	11	9	20	60	M6×20	12 400	12 300	153	71.8 480	71.8 480
									18 100	21 100	262	195 1 090	195 1 090
									22 200	28 200	349	336 1 740	336 1 740

Note<sup>(1)</sup>: Track rail lengths L are shown in Table 11 on page A-27.  
<sup>(2)</sup>: Track rail mounting bolts are not appended. Hexagon socket bolts of JIS B 1176 strength division 12.9 or equivalent are recommended. Values in parentheses are applicable to the track rail of supplemental code "/M4" of special specification.  
<sup>(3)</sup>: The directions of basic dynamic load rating (C), basic static load rating (C<sub>0</sub>) and static moment rating (T<sub>0</sub>, T<sub>X</sub> and T<sub>Y</sub>) are shown in the sketches below. The upper values in the T<sub>X</sub> and T<sub>Y</sub> column apply to one slide unit, and the lower values apply to two units in close contact

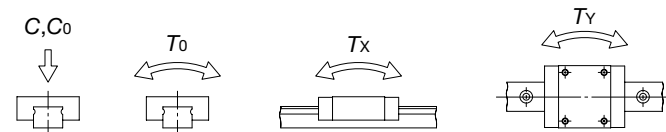

Example of identification number of assembled set (For details, see "Identification number and specification".)

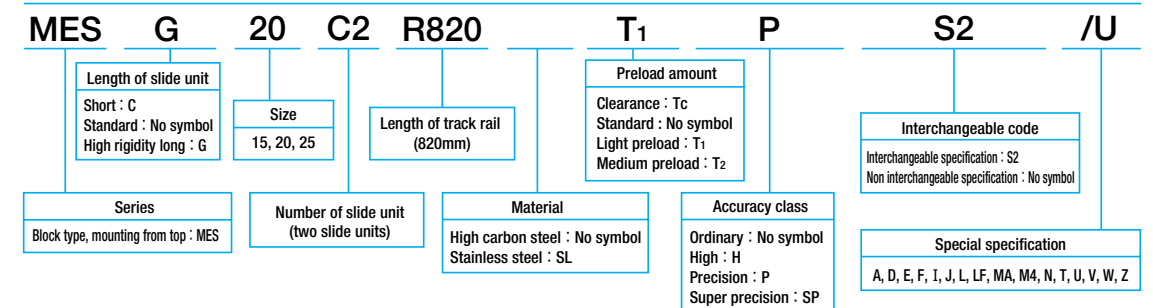

※ In case ordering track rail only, model code is changed as shown below.  
 Track rail of interchangeable ME → Model code LW (Ex:LWE20R820PS2)

Block type, mounting from top  
**MESC**  
**MES**  
**MESG**

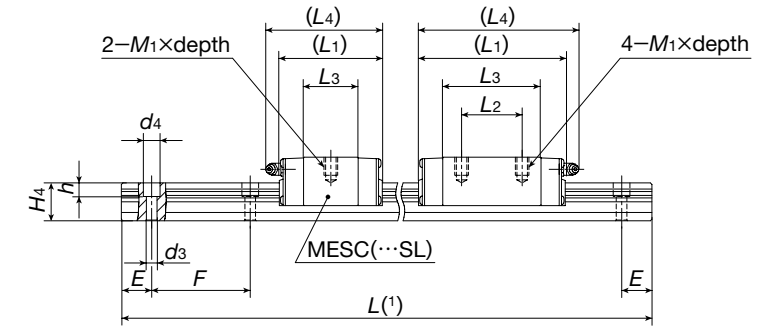
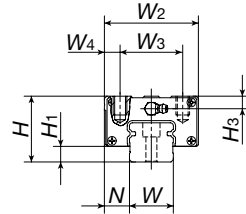

Model number	Interchangeable	Mass (Reference)		Dimension of assembly mm			Dimensions of slide unit mm							
		Slide unit kg	Track rail kg/m	H	H <sub>1</sub>	N	W <sub>2</sub>	W <sub>3</sub>	W <sub>4</sub>	L <sub>1</sub>	L <sub>2</sub>	L <sub>3</sub>	L <sub>4</sub>	M <sub>1</sub> ×depth
<b>MESC 30</b>	☆	0.46	5.09	42	10	16	60	40	10	68	—	36	78	M 8×12
<b>MESC 30···SL</b>	☆									97	40	64.8	107	
<b>MES 30</b>	☆	0.78	5.09	42	10	16	60	40	10	128.5	60	96.5	139	M 8×12
<b>MES 30···SL</b>	☆									—	—	—	—	
<b>MESG 30</b>	☆	1.13	11.2	60	14	20.5	86	60	13	125	60	81.4	136	M10×15
<b>MESG 30···SL</b>	☆									—	—	—	—	
<b>MESC 35</b>	☆	0.67	6.85	48	11	18	70	50	10	78	—	41.6	90	M 8×12
<b>MES 35</b>	☆	1.21								111	50	74.6	123	
<b>MES 45</b>	☆	2.05	11.2	60	14	20.5	86	60	13	125	60	81.4	136	M10×15

Note<sup>(1)</sup>: Track rail lengths L are shown in Table 11 on page A-27.  
<sup>(2)</sup>: Track rail mounting bolts are not appended. Hexagon socket bolts of JIS B 1176 strength division 12.9 or equivalent are recommended.  
<sup>(3)</sup>: The directions of basic dynamic load rating (C), basic static load rating (C<sub>0</sub>) and static moment rating (T<sub>0</sub>, T<sub>x</sub> and T<sub>y</sub>) are shown in the sketches below. The upper values in the T<sub>x</sub> and T<sub>y</sub> column apply to one slide unit, and the lower values apply to two units in close contact.

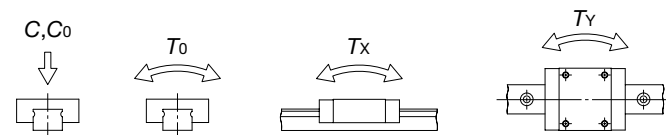

H <sub>3</sub>	Dimensions of track rail mm							Recommended mounting bolt for track rail <sup>(2)</sup> mm Bolt size x length	Basic dynamic load rating <sup>(3)</sup> C N	Basic static load rating <sup>(3)</sup> C <sub>0</sub> N	Static moment rating <sup>(3)</sup>		
	W	H <sub>4</sub>	d <sub>3</sub>	d <sub>4</sub>	h	E	F				T <sub>0</sub> N·m	T <sub>x</sub> N·m	T <sub>y</sub> N·m
8	28	25	7	11	9	20	80	M 6×25	20 600	18 800	287	129 855	129 855
									29 500	31 300	479	328 1 920	328 1 920
10	34	28	9	14	12	20	80	M 8×30	29 900	26 800	412	176 1 190	162 1 100
									42 900	44 700	686	448 2 660	412 2 450
13	45	34	11	17.5	14	22.5	105	M10×35	61 100	60 200	1 210	672 4 070	618 3 750

Example of identification number of assembled set (For details, see "Identification number and specification".)

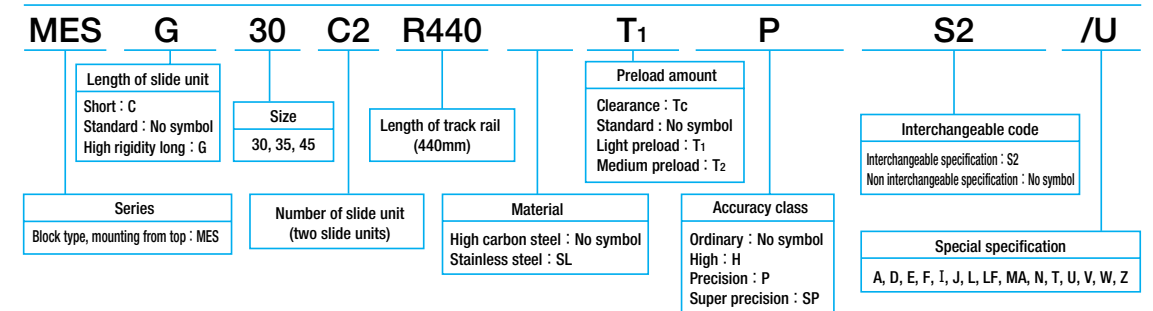

※ In case ordering track rail only, model code is changed as shown below.  
 Track rail of interchangeable ME → Model code LWE (Ex:LWE30R440PS2)

# C-Lube Linear Way MH

MH/MHT/MHD/MHS

**IKO C-Lube Linear Way MH features the largest load ratings and rigidity among all ball types and incorporating the C-Lube as a components part for lubrication in the slide unit to achieve maintenance free operations for a long period of time.**

## Long-term maintenance free

The lubricant in the C-Lube keeps the lubrication performance for a long period of time and achieves long-term maintenance free operations. (5 years and 20,000km) So man-hours for troublesome lubrication control can be reduced.

## Interchangeability

Interchangeable specification is also available. The track rails and the slide units of interchangeable specification can be handled separately and can be assembled to make a set as required. Two types of slide units with different lengths are prepared. The best type and size can be selected these entire slide units can be freely assembled on the same track rail.

## Light weight and compact

The C-Lube is incorporated in the slide unit of High Rigidity type Linear Way H series without changing the external dimensions of the slide unit.

## Smooth and light motion

As the C-Lube is not in contact with the track rail, frictional resistance does not increase. A smooth and light motion is ensured.

## Flange type and block type

Four kinds of slide units are available; two flange types for different mounting directions and two kinds of narrow block type with different height and mounting dimensions.

## Length of slide unit

A standard type slide unit and a high rigidity long type slide unit both having the same sectional dimensions are available.

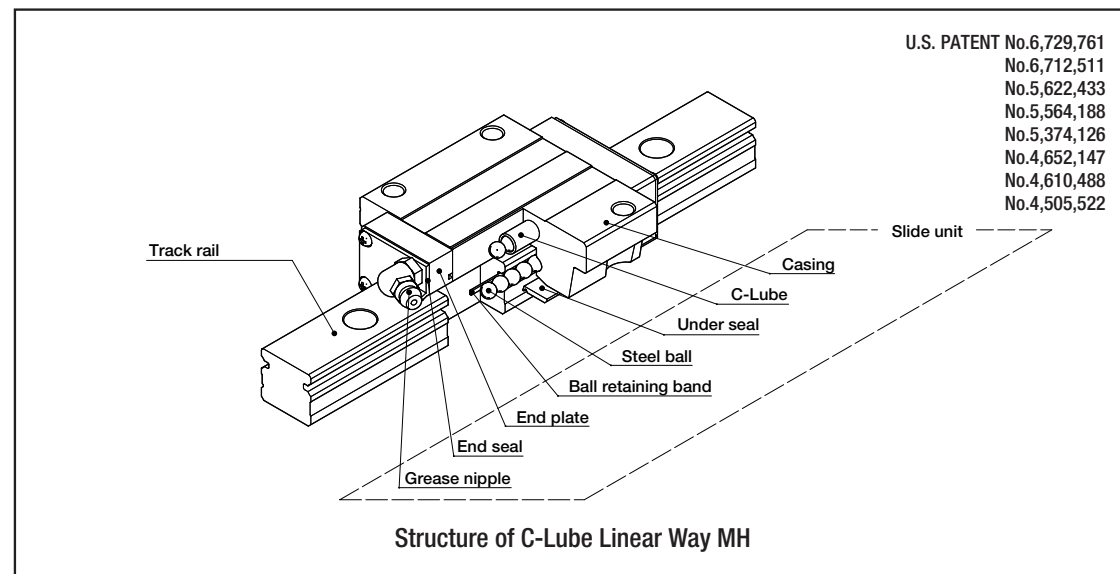

## Variation of IKO C-Lube Linear Way MH

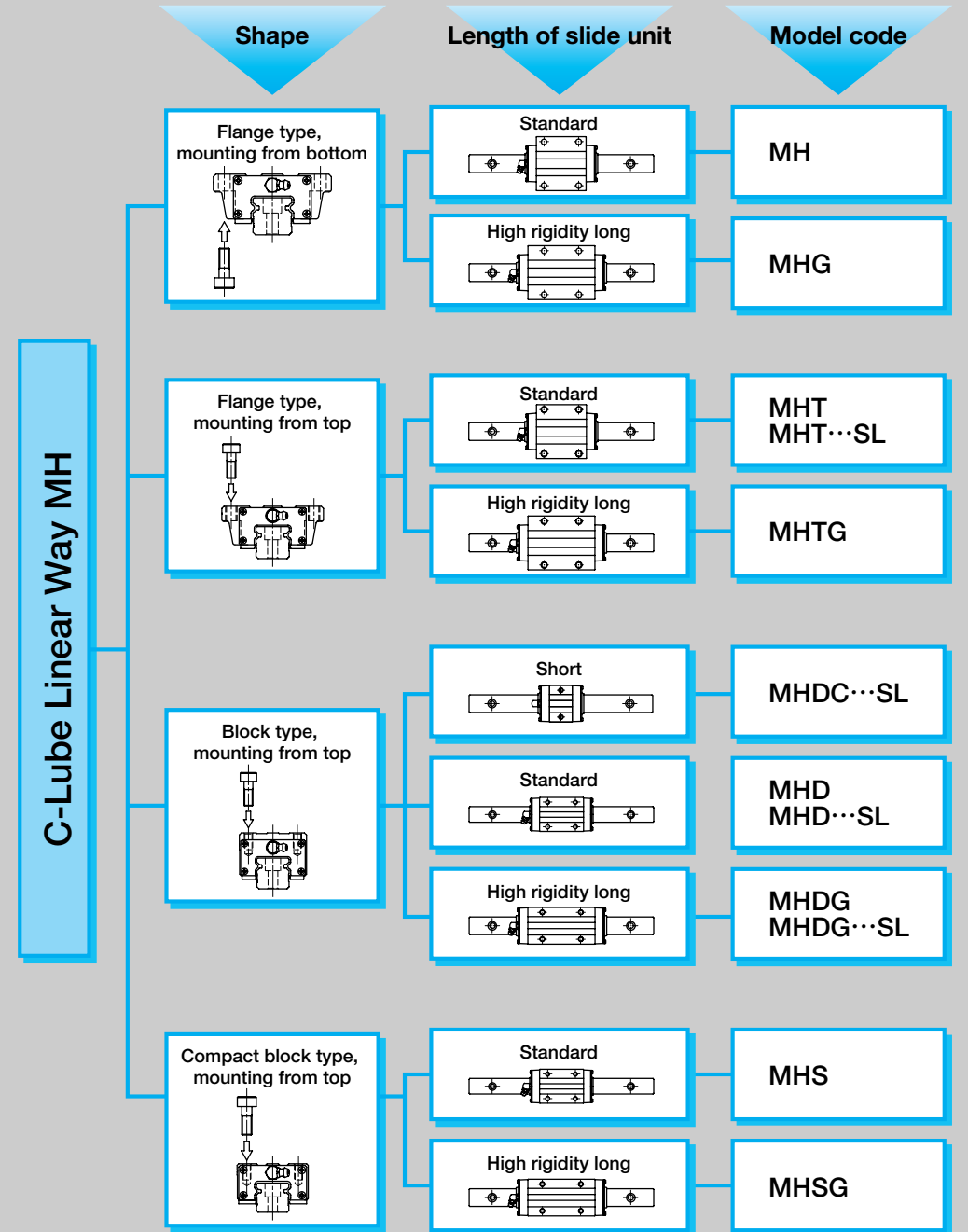

## ● Identification number and specification

The specification of C-Lube Linear Way MH is indicated by the identification number, consisting of a model code, a size, a part code, a preload symbol, a classification symbol and any supplemental codes. For details of each specification, see page 78.

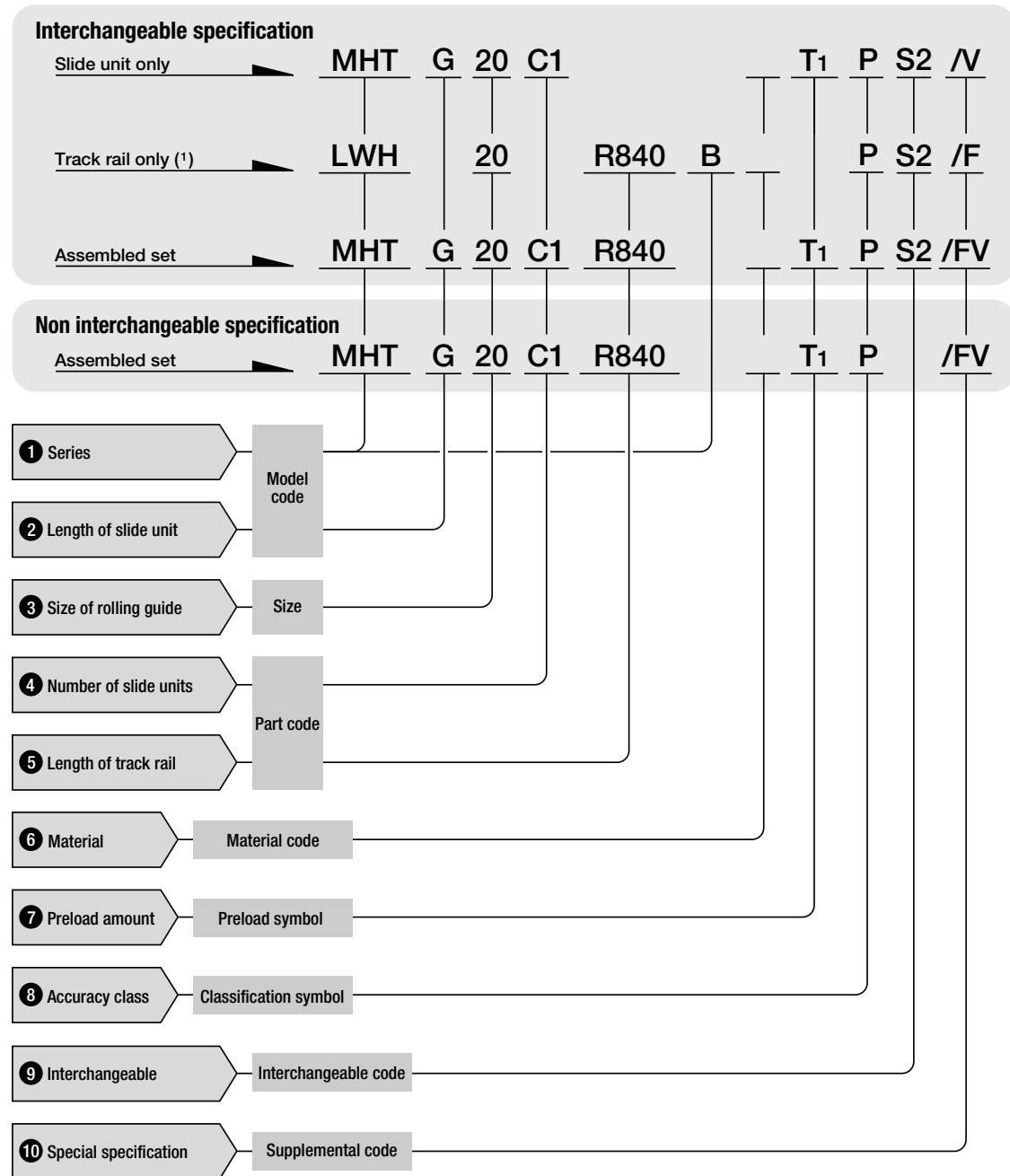

Note(\*): In case ordering track rail only, model code should be changed as shown below.  
Track rail of interchangeable MH → Model code LWH (Ex: LWH15R900BPS2)

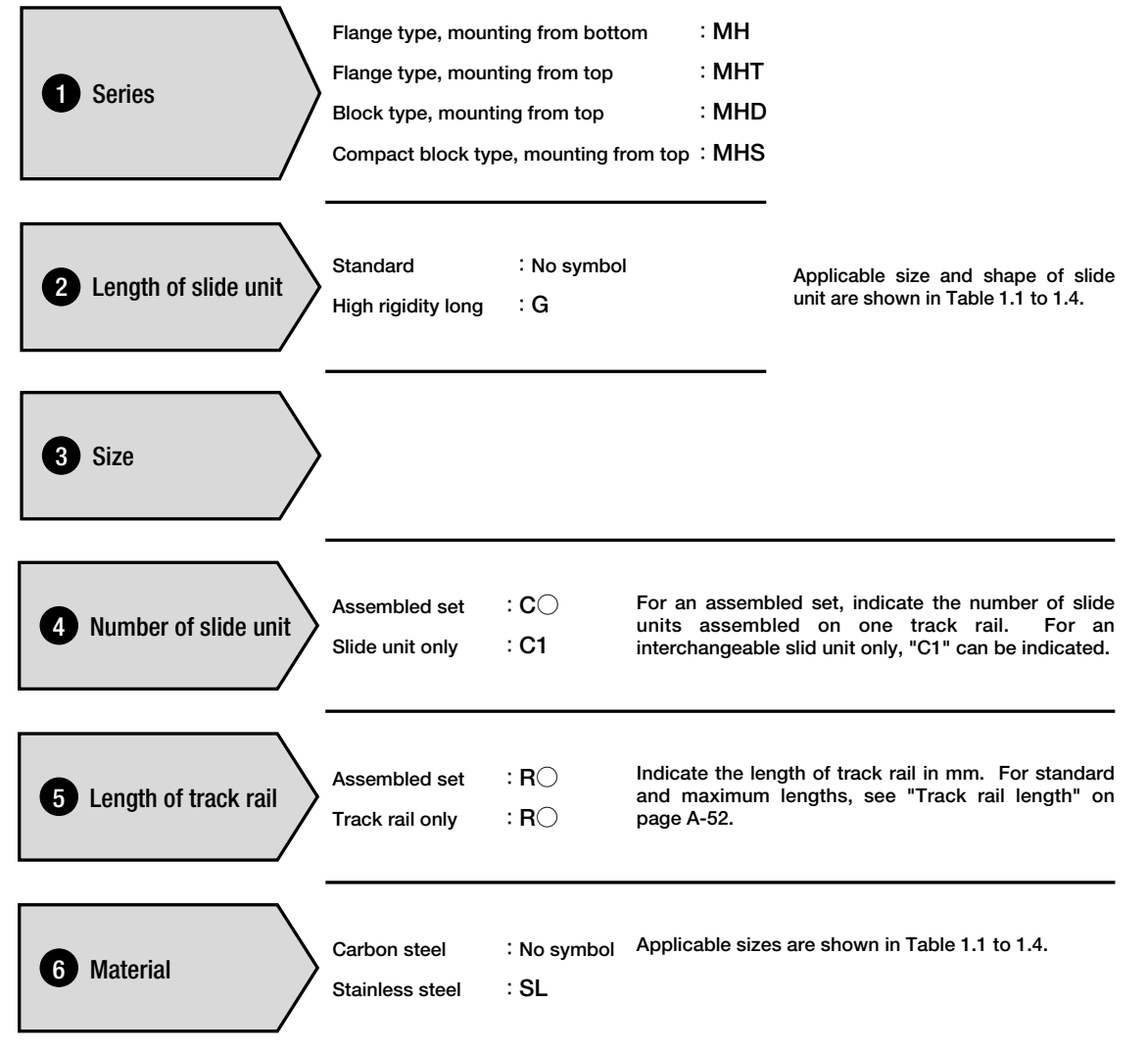



Type and size of standard type C-Lube Linear Way MH  
Table 1.1 Flange type, mounting from bottom

Size	Type	Carbon steel	
		Standard MH	High rigidity long MHG
15		☆	—
20		☆	☆
25		☆	☆
30		☆	☆
35		☆	☆
45		☆	☆

Table 1.2 Flange type, mounting from top

Size	Type	Carbon steel		
		Standard MHT	High rigidity long MHTG	Standard MHT...SL
8 <sup>(1)</sup>		—	—	☆
10 <sup>(1)</sup>		—	—	☆
12 <sup>(1)</sup>		☆	—	☆
15		☆	—	—
20		☆	☆	—
25		☆	☆	—
30		☆	☆	—
35		☆	☆	—
45		☆	☆	—

Note(1) : Size 8, 10 and 12 can be mounted also from bottom.  
Remark : The mark ☆ indicates that it is also applicable to interchangeable specification.

Table 1.3 Block type, mounting from top

Size	Type	Carbon steel		Stainless steel		
		Standard MHD	High rigidity long MHDG	Short MHDC...SL	Standard MHD...SL	High rigidity long MHDG...SL
8		—	—	☆	☆	☆
10		—	—	☆	☆	☆
12		☆	—	☆	☆	☆
15		☆	—	—	—	—
20		—	—	—	—	—
25		☆	☆	—	—	—
30		☆	☆	—	—	—
35		☆	☆	—	—	—
45		☆	☆	—	—	—

Table 1.4 Compact block type, mounting from top

Size	Type	Carbon steel	
		Standard MHS	High rigidity long MHSG
15		☆	—
20		☆	☆
25		☆	☆
30		☆	☆

Remark : The mark ☆ indicates that it is also applicable to interchangeable specification.

**7 Preload amount**

Clearance : T<sub>0</sub>  
 Standard : No symbol  
 Light preload : T<sub>1</sub>  
 Medium preload : T<sub>2</sub>  
 Heavy preload : T<sub>3</sub>

Specify this items for an assembled set or an interchangeable single slide unit.  
 Applicable preload and size are shown in Table 2.  
 For detail of preload amount, see page 86.

Table 2 Preload of C-Lube Linear Way MH

Size	Preload class and symbol				
	Clearance (T <sub>0</sub> )	Standard (No symbol)	Light preload (T <sub>1</sub> )	Medium preload (T <sub>2</sub> )	Heavy preload (T <sub>3</sub> )
8	○	☆	○	—	—
10	○	☆	○	—	—
12	○	☆	○	—	—
15	—	☆	☆	○	○
20	—	☆	☆	○	○
25	—	☆	☆	○	○
30	—	☆	☆	○	○
35	—	☆	☆	○	○
45	—	☆	☆	○	○

Remark : The mark ☆ indicates that it is also applicable to interchangeable specification.

**8 Accuracy class**

High class : H  
 Precision class : P  
 Super precision : SP

In interchangeable specification, please combine same accuracy codes on both slide unit and track rail. For combination of accuracy and preload, see Table 3.  
 Detail of accuracy is shown in page 81.

Table 3 Accuracy class and size

Size	Accuracy class		
	High class (H)	Precision class (P)	Super precision (SP)
8	☆	☆	—
10	☆	☆	—
12	☆	☆	—
15	☆	☆	○
20	☆	☆	○
25	☆	☆	○
30	☆	☆	○
35	☆	☆	○
45	☆	☆	○

Remark : The mark ☆ indicates that it is also applicable to interchangeable specification.

**9 Interchangeable**

Interchangeable : S2

Specify this item for the interchangeable specification products. Assemble track rails and slide units with the same interchangeable code.

10 Special specifications

Applicable special specifications are shown in Table 4. When a combination of several special specifications is required, please refer Table 5 and arrange their supplemental codes in alphabetical order. For detail of specifications are shown on page 88.

Table 4 Applicable specifications

Specifications	Supplemental code	Set product	Track rail only	Slide unit only	Dimension
Butt jointing track rail	A	○ <sup>(1)</sup>	—	—	
Opposite reference surfaces arrangement	D	☆	—	—	
Specified rail mounting hole positions	E	☆	☆	—	
Caps for rail mounting holes	F	☆ <sup>(2)</sup>	☆ <sup>(2)</sup>	—	
Appending inspection sheet	I	○	—	—	
Female threads for bellows	J	☆ <sup>(3)</sup>	☆ <sup>(3)</sup>	☆ <sup>(3)</sup>	See table 6.1, 6.2 and 6.3
Black chrome surface treatment	L	☆ <sup>(4)</sup> (8)	☆ <sup>(3)</sup>	—	
Fluoric black chrome surface treatment	LF	☆ <sup>(3)</sup>	—	—	
With track rail mounting bolts (Applicable to set order)	MA	☆	—	—	See table 7
Without track rail mounting bolts (Applicable to track rail order)	MN	—	☆	—	
No rubber end seals	N	☆	—	☆	
Rail cover plate for track rail <sup>(1)</sup>	PS	○ <sup>(5)</sup>	—	—	
Butt jointing interchangeable track rail	T	☆ <sup>(3)</sup> (6)	☆ <sup>(3)</sup>	—	
Under seals	U	☆ <sup>(7)</sup>	—	☆ <sup>(7)</sup>	See table 8
Double end seals	V	☆ <sup>(3)</sup>	—	☆ <sup>(3)</sup>	See table 9
Matched sets to be used as an assembled group	W	○	—	—	
Scrapers	Z	☆ <sup>(3)</sup>	—	☆ <sup>(3)</sup>	See table 10

Note<sup>(1)</sup>: Not applicable to size 12 carbon steel model.

(2): Not applicable to size 8 and 10.

(3): Not applicable to size 8, 10 and 12.

(4): Only "LR" is applicable to size 8, 10 and 12.

(5): Not applicable to size 8, 10, 12 and 15.

(6): Not applicable to non-interchangeable specification.

(7): Applicable to size 8, 10 and 12.

(8): Not applicable top size 8, 10 and 12 of non-interchangeable specification.

Remark: The mark ☆ indicates that it is also applicable to interchangeable specification.

Table 5 Combination of special specifications

D	○																							
E	—	—																						
F	○	☆	☆																					
I	○	○	○	○																				
J	○	☆	☆	☆	○																			
L	○	☆	☆	☆	○	☆																		
LF	○	☆	☆	☆	○	☆	—																	
MA	○	☆	☆	☆	○	☆	☆	☆																
MN	—	—	☆	☆	—	☆	—	—	—															
N	○	☆	☆	—	○	—	☆	☆	☆	—														
PS	—	○	○	—	○	—	—	—	○	—	—													
T	—	☆	☆	☆	—	—	☆	☆	☆	☆	☆	—												
U	○	☆	☆	☆	○	—	☆	☆	☆	—	—	—	—											
V	○	☆	☆	☆	○	★	☆	☆	☆	—	—	○	☆	—										
W	○	○	—	○	○	○	○	○	○	—	○	○	—	○	○									
Z	○	☆	☆	☆	○	★	☆	☆	☆	—	—	—	☆	—	★	○								
	A	D	E	F	I	J	L	LF	MA	MN	N	PS	T	U	V	W								

Remark 1: In the table, the mark ○ indicates that this combination can be made.

2: The mark ☆ indicates that the combination is available for also interchangeable specification.

3: When the specification with ★ is required, please consult IKO.

4: When a combination of several specifications is required, arrange their supplemental codes in alphabetical order.

Table 6.1 Female threads for bellows for flange type MH (Supplemental code /JJ)

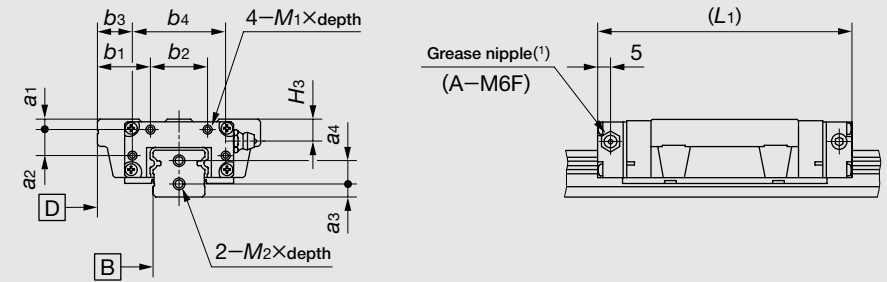

unit : mm

Model number	Slide unit									Track rail		
	a1	a2	b1	b2	b3	b4	M1×depth	L1 <sup>(2)</sup>	H3	a3	a4	M2×depth
MH(T) 15	3	7	15.5	16	9.5	28	M3×6	83	6.5	4	8	M3×6
MH(T) 20	4	10	20.5	22	13.5	36	M3×6	99	8.5	5	9	M4×8
MH(T) G 20								128				
MH(T) 25	4	13	22	26	15	40	M3×6	110	8.5	5	12	M4×8
MH(T) G 25								133				
MH(T) 30	5	17	28	34	20	50	M3×6	128	11	6	14	M4×8
MH(T) G 30								154				
MH(T) 35	6	20	30	40	20	60	M3×6	137	13	7	15	M4×8
MH(T) G 35								165				
MH(T) 45	7	26	35	50	23	74	M4×8	160	15	8	19	M5×10
MH(T) G 45								203				

Note<sup>(1)</sup>: The specification and mounting positions of grease nipple are different from those of the standard specification product. Size 15 models are provided with a special specification grease nipple (NPB2 type). For detail of dimensions, consult IKO for further information.

(2): The values are for the slide unit with female threads for bellows at both ends.

Table 6.2 Female threads for bellows for block type MHD (Supplemental code /JJ)

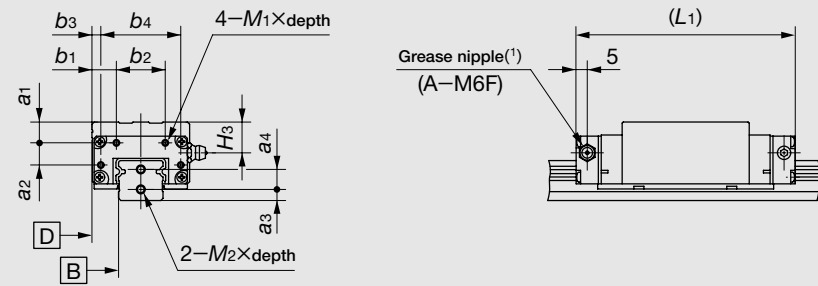

unit : mm

Model number	Slide unit								Track rail			
	a1	a2	b1	b2	b3	b4	M1×depth	L1 <sup>(2)</sup>	H3	a3	a4	M2×depth
MHD 15	7	7	9	16	3	28	M3×6	83	10.5	4	8	M3×6
MHD 25	8	13	11	26	4	40	M3×6	110	12.5	5	12	M4×8
MHDG 25								133				
MHD 30	8	17	13	34	5	50	M3×6	128	14	6	14	M4×8
MHDG 30								154				
MHD 35	13	20	15	40	5	60	M3×6	137	20	7	15	M4×8
MHDG 35								165				
MHD 45	17	26	18	50	6	74	M4×8	160	25	8	19	M5×10
MHDG 45								203				

Note<sup>(1)</sup> : The specification and mounting positions of grease nipple are different from those of the standard specification product. Size 15 models are provided with a special specification grease nipple (NPB2 type). For detail of dimensions, consult **I I K O** for further information.

<sup>(2)</sup> : The values are for the slide unit with female threads for bellows at both ends.

Table 6.3 Female threads for bellows for compact block type MHS (Supplemental code /JJ)

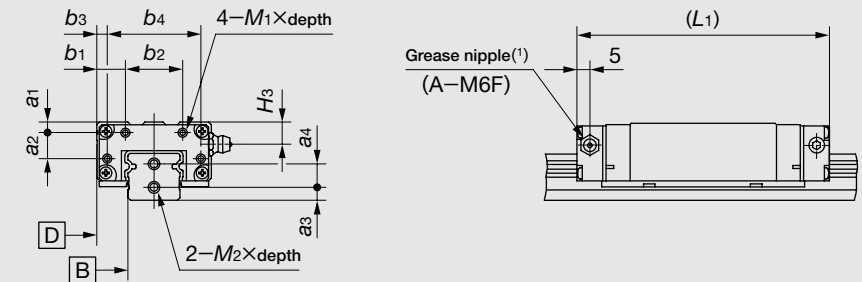

unit : mm

Model number	Slide unit								Track rail			
	a1	a2	b1	b2	b3	b4	M1×depth	L1 <sup>(2)</sup>	H3	a3	a4	M2×depth
MHS 15	3	7	9	16	3	28	M3×6	83	6.5	4	8	M3×6
MHS 20	4	10	11	22	4	36	M3×6	99	8.5	5	19	M4×8
MHSG 20								128				
MHS 25	4	13	11	26	4	40	M3×6	110	8.5	5	12	M4×8
MHSG 25								133				
MHS 30	5	17	13	34	5	50	M3×6	128	11	6	14	M4×8
MHSG 30								154				

Note<sup>(1)</sup> : The specification and mounting positions of grease nipple are different from those of the standard specification product. Size 15 models are provided with a special specification grease nipple (NPB2 type). For detail of dimensions, consult **I I K O** for further information.

<sup>(2)</sup> : The values are for the slide unit with female threads for bellows at both ends.

Table 7 Appended bolts size for mounting track rail of MH (Supplemental code /MA)

Model number	Bolt size
MH 8···SL	M 2×8
MH 10···SL	M 3×8
MH 12	M 3×12
MH 15	M 4×16
MH 20	M 5×18
MH 25	M 6×22
MH 30	M 8×28
MH 35	M 8×28
MH 45	M12×35

Remark 1 : The table shows representative model numbers but is applicable to all models of the same size.

2 : Hexagon socket bolts of JIS B 1176 strength division 12.9 are appended.

Table 8  $H_1$  dimension of slide unit with under seals (Supplemental code /U)

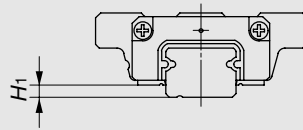

unit : mm

Model number	$H_1$
<b>MH 8...SL</b>	1.5
<b>MH 10...SL</b>	1.8
<b>MH 12</b>	3.2

Remark 1 : The table shows representative model numbers but is also applicable to all models in the same size of MH series.  
 2 :  $H_1$  dimension of size 12 models is the same as the dimension without under seals.

Table 9 Slide unit with double end seals (Supplemental code /VV)

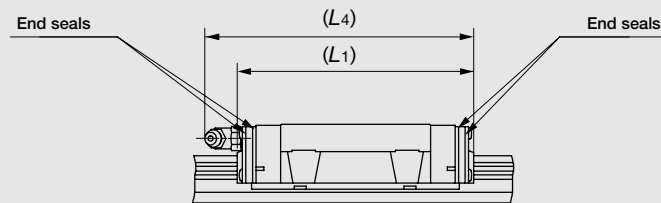

unit : mm

Model number	$L_1$	$L_4$	Model number	$L_1$	$L_4$
<b>MH 15</b>	72	77	<b>MH 35</b>	133	146
<b>MH 20</b>	91	104	<b>MHG 35</b>	161	173
<b>MHG 20</b>	119	133	<b>MH 45</b>	159	170
<b>MH 25</b>	104	116	<b>MHG 45</b>	202	213
<b>MHG 25</b>	127	139			
<b>MH 30</b>	122	134			
<b>MHG 30</b>	148	160			

Remark 1 : The table shows representative model numbers but is applicable to all models of the same size.  
 2 : The total lengths of slide unit with double end seals at both ends are shown.

Table 10 Slide unit with scrapers (Supplemental code /ZZ)

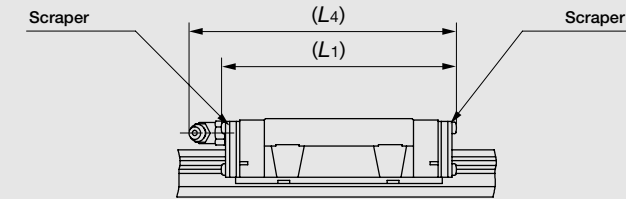

unit : mm

Model number	$L_1$	$L_4$	Model number	$L_1$	$L_4$
<b>MH 15</b>	73	75	<b>MH 35</b>	133	146
<b>MH 20</b>	91	104	<b>MHG 35</b>	161	174
<b>MHG 20</b>	119	133	<b>MH 45</b>	160	171
<b>MH 25</b>	104	116	<b>MHG 45</b>	203	214
<b>MHG 25</b>	126	139			
<b>MH 30</b>	124	135			
<b>MHG 30</b>	150	161			

Remark 1 : The table shows representative model numbers but is applicable to all models of the same size.  
 2 : The total lengths of slide unit with scrapers at both ends are shown.

## Track rail length

Standard and maximum lengths of track rail are shown in Table 11.1 and 11.2. Track rail in any lengths are also available. Simply indicate the necessary length of track rail in millimeter (mm) in the identification number.

- In non-interchangeable specification, for track rail longer than the maximum length shown in Table 11.1 and 11.2, butt-jointing track rails are available upon request. In this case, indicate supplemental code "/A" in the identification number.
- E dimensions at both ends are the same unless otherwise specified. To change these dimensions, specify the specified rail mounting hole positions (supplemental code "/E") of special specification. For detail, see page 91.

Table 11.1 Standard and maximum lengths of MH

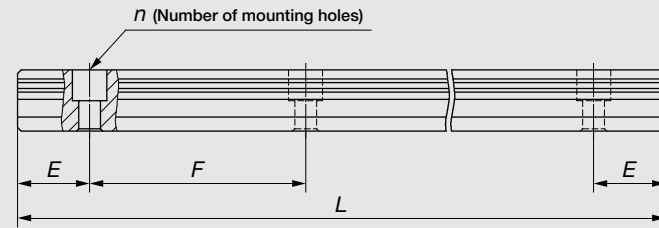

unit : mm

Item	Model number	MH 12	MH 15	MH 20	MH 25	MH 30
Standard length $L(n)$		80( 2)	180( 3)	240( 4)	240( 4)	480( 6)
		160( 4)	240( 4)	480( 8)	480( 8)	640( 8)
		240( 6)	360( 6)	660(11)	660(11)	800(10)
		320( 8)	480( 8)	840(14)	840(14)	1 040(13)
		400(10)	660(11)	1 020(17)	1 020(17)	1 200(15)
		480(12)	900(15)	1 200(20)	1 200(20)	1 520(19)
		560(14)	1 200(20)	1 500(25)	1 500(25)	2 000(25)
		640(16)			1 980(33)	
Mounting hole pitch $F$		40	60	60	60	80
$E$		20	30	30	30	40
Reference dimension $E^{(1)}$	Over (Incl.)	5.5	7	8	9	10
	Under	25.5	37	38	39	50
Maximum length $^{(2)}$		1 480	1 500 (3 000)	1 980 (3 000)	3 000 (3 960)	2 960 (4 000)
Item	Model number	MH 35	MH 45			
Standard length $L(n)$		480( 6)	840( 8)			
		640( 8)	1 050(10)			
		800(10)	1 260(12)			
		1 040(13)	1 470(14)			
		1 200(15)	1 995(19)			
	1 520(19)					
Mounting hole pitch $F$		80	105			
$E$		40	52.5			
Reference dimension $E^{(1)}$	Over (Incl.)	10	12.5			
	Under	50	65			
Maximum length $^{(2)}$		2 960 (4 000)	2 940 (3 990)			

Note (1) : Not applied to optional specification "female threads for bellows" (supplemental code "/J", "/JJ")

(2) : The track rails can be manufactured up to the maximum length shown in parentheses. If required, please consult IICO.

Remark : The above table shows representative model number but is applicable to all models of the same size.

Table 11.2 Standard and maximum length of MH...SL (Stainless models)

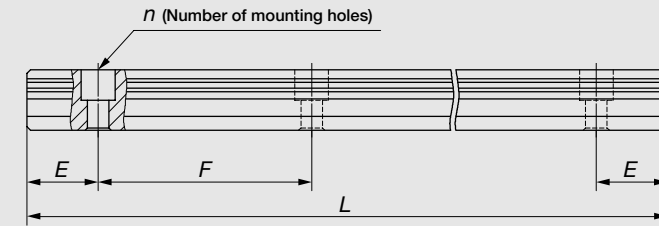

unit : mm

Item	Model number	MH 8...SL	MH 10...SL	MH 12...SL
Standard length $L(n)$		40( 2)	50( 2)	80( 2)
		80( 4)	100( 4)	160( 4)
		120( 6)	150( 6)	240( 6)
		160( 8)	200( 8)	320( 8)
		200(10)	250(10)	400(10)
		240(12)	300(12)	480(12)
		280(14)	350(14)	560(14)
			400(16)	640(16)
		450(18)	720(18)	
		500(20)		
Mounting hole pitch $F$		20	25	40
$E$		10	12.5	20
Reference dimension $E^{(1)}$	Over (Incl.)	4.5	5	5.5
	Under	14.5	17.5	25.5
Maximum length $^{(2)}$		480 (1 000)	850 (1 000)	1 000 (1 480)

Note (1) : Not applied to optional specification "female threads for bellows" (supplemental code "/J", "/JJ")

(2) : The track rails can be manufactured up to the maximum length shown in parentheses. If required, please consult IICO.

Remark : The above table shows representative model number but is applicable to all models of the same size.

Flanged shape, mounting from bottom  
**MH**  
**MHG**

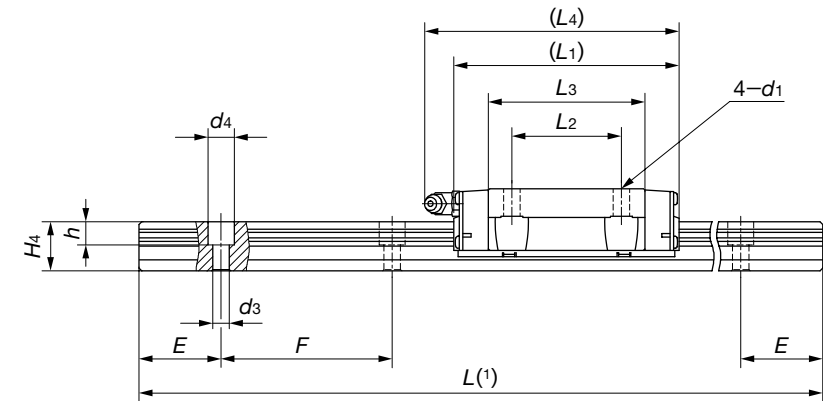
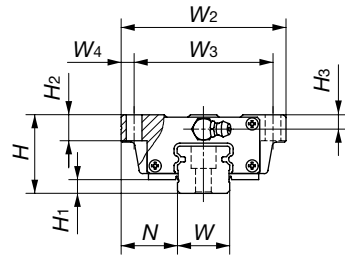

Model number	Interchangeable	Mass (Reference)		Dimension of assembly mm			Dimension of slide unit mm								
		Slide unit kg	Track rail kg/m	H	H <sub>1</sub>	N	W <sub>2</sub>	W <sub>3</sub>	W <sub>4</sub>	L <sub>1</sub>	L <sub>2</sub>	L <sub>3</sub>	L <sub>4</sub>	d <sub>1</sub>	
<b>MH 15</b>	☆	0.22	1.47	24	4.5	16	47	38	4.5	66	30	44.2	69	4.5	
<b>MH 20</b>	☆	0.47	2.56	30	5	21.5	63	53	5	83	40	56	95	6	
<b>MHG 20</b>	☆	0.69								112		84.8	124		
<b>MH 25</b>	☆	0.69	3.50	36	6.5	23.5	70	57	6.5	95	45	63.9	106	7	
<b>MHG 25</b>	☆	0.91								118		86.6	129		
<b>MH 30</b>	☆	1.28	4.82	42	7	31	90	72	9	113	52	80.6	124	9	
<b>MHG 30</b>	☆	1.69								139		106.6	150		
<b>MH 35</b>	☆	1.79	6.85	48	8	33	100	82	9	123	62	86.2	135	9	
<b>MHG 35</b>	☆	2.35								151		114	163		
<b>MH 45</b>	☆	3.17	10.7	60	10	37.5	120	100	10	147	80	103.4	158	11	
<b>MHG 45</b>	☆	4.34								190		146.6	201		

Dimension of track rail mm		Recommended mounting bolt for track rail <sup>(2)</sup> mm Bolt size x length	Basic dynamic load rating <sup>(3)</sup> C N	Basic static load rating <sup>(3)</sup> C <sub>0</sub> N	Static moment rating <sup>(3)</sup>		
H <sub>2</sub>	H <sub>3</sub>				T <sub>0</sub> N·m	T <sub>x</sub> N·m	T <sub>y</sub> N·m
7	4.5	M 4×16	11 600	13 400	112	95.6 556	95.6 556
10	5.5	M 5×18	18 100	21 100	232	195 1 090	195 1 090
			24 100	31 700	349	421 2 140	421 2 140
10	6.5	M 6×22	25 200	28 800	362	309 1 690	309 1 690
			30 800	38 300	483	533 2 740	533 2 740
10	8	M 8×28	35 400	40 700	623	536 2 820	536 2 820
			42 700	53 200	814	894 4 460	894 4 460
13	10	M 8×28	48 700	53 700	823	631 3 480	579 3 190
			59 500	71 600	1 100	1 090 5 570	1 000 5 110
15	13	M12×35	74 600	80 200	1 610	1 150 6 190	1 060 5 690
			95 200	114 000	2 280	2 240 11 100	2 020 10 200

Note<sup>(1)</sup>: Track rail lengths L are shown in Table 11.1 on page A-52.  
<sup>(2)</sup>: Track rail mounting bolts are not appended. Hexagon socket bolts of JIS B 1176 strength division 12.9 or equivalent are recommended.  
<sup>(3)</sup>: The directions of basic dynamic load rating (C), basic static load rating (C<sub>0</sub>) and static moment rating (T<sub>0</sub>, T<sub>x</sub> and T<sub>y</sub>) are shown in the sketches below. The upper values in the T<sub>x</sub> and T<sub>y</sub> column apply to one slide unit, and the lower values apply to two units in close contact.  
 Remark 1: The mark ☆ indicates that the combination is available for also interchangeable specification.  
 2: For the shape of grease nipple, see page 99.

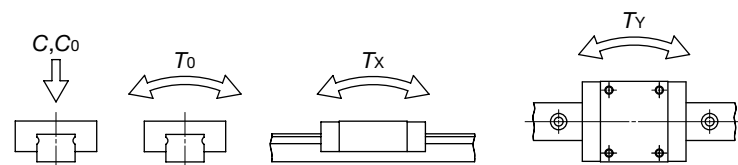

Example of identification number for assembled set (For details, see "Identification number and specification".)

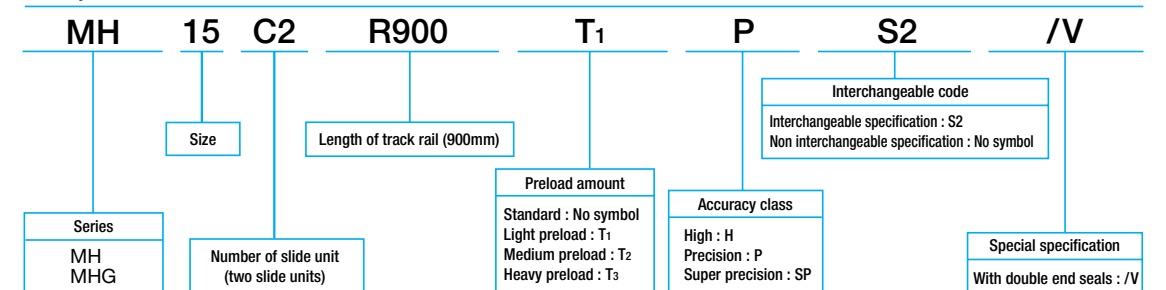

※ In case ordering track rail only, model code is changed as shown below.  
 Track rail of interchangeable MH → Model code LWH (Ex: LWH15R900BPS2)

Flange type, mounting from Top  
MHT  
MHTG

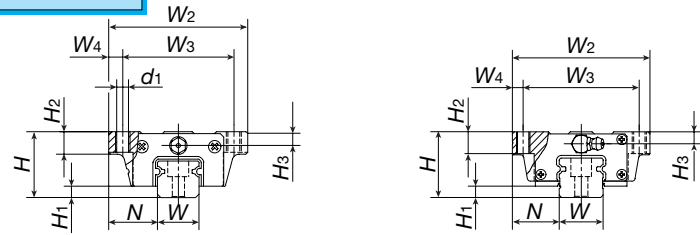

MHT 8...SL  
MHT10...SL  
MHT12(...SL)

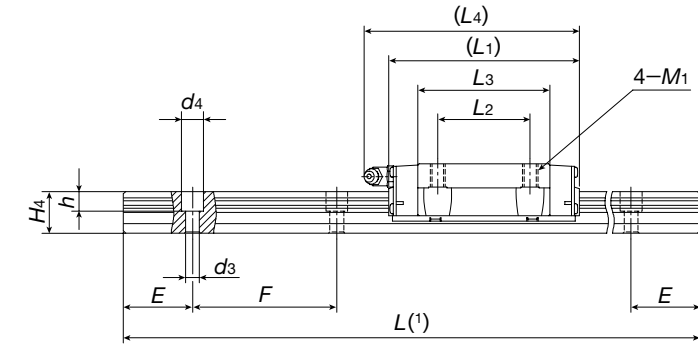

Model number	Interchangeable	Mass (Reference)		Dimension of assembly mm			Dimension of slide unit mm										
		Slide unit kg	Track rail kg/m	H	H <sub>1</sub>	N	W <sub>2</sub>	W <sub>3</sub>	W <sub>4</sub>	L <sub>1</sub>	L <sub>2</sub>	L <sub>3</sub>	L <sub>4</sub>	d <sub>1</sub> <sup>(4)</sup>	M <sub>1</sub>	H <sub>2</sub>	H <sub>3</sub>
MHT 8...SL	☆	0.015	0.32	10	2.1	8	24	19	2.5	24	10	15.3	—	1.9	M 2.3	3.5	2
MHT 10...SL	☆	0.031	0.47	12	2.4	10	30	24	3	32	12	21.4	—	2.6	M 3	4.5	2.5
MHT 12	☆	0.108	0.86	19	3.2	14	40	32	4	46	15	31.6	50	3.4	M 4	6	4
MHT 12...SL	☆																
MHT 15	☆	0.22	1.47	24	4.5	16	47	38	4.5	66	30	44.2	69	—	M 5	7	4.5
MHT 20	☆	0.47	2.56	30	5	21.5	63	53	5	83	40	56	95	—	M 6	10	5.5
MHTG 20	☆	0.69								112		84.8	124	—			
MHT 25	☆	0.69	3.50	36	6.5	23.5	70	57	6.5	95	45	63.9	106	—	M 8	10	6.5
MHTG 25	☆	0.91								118		86.6	129	—			
MHT 30	☆	1.28	4.82	42	7	31	90	72	9	113	52	80.6	124	—	M10	10	8
MHTG 30	☆	1.69								139		106.6	150	—			
MHT 35	☆	1.79	6.85	48	8	33	100	82	9	123	62	86.2	135	—	M10	13	10
MHTG 35	☆	2.35								151		114	163	—			
MHT 45	☆	3.17	10.7	60	10	37.5	120	100	10	147	80	103.4	158	—	M12	15	13
MHTG 45	☆	4.34								190		146.6	201	—			

Dimension of track rail mm							Recommended mounting bolt for track rail <sup>(2)</sup> mm Bolt size x length	Basic dynamic load rating <sup>(3)</sup> C N	Basic static load rating <sup>(3)</sup> C <sub>0</sub> N	Static moment rating <sup>(3)</sup>		
W	H <sub>4</sub>	d <sub>3</sub>	d <sub>4</sub>	h	E	F				T <sub>0</sub> N·m	T <sub>x</sub> N·m	T <sub>y</sub> N·m
8	6	2.4	4.2	2.3	10	20	M 2×8	1 510	2 120	8.8	5.5 32.0	4.7 26.9
10	7	3.5	6	3.5	12.5	25	M 3×8	2 640	3 700	19.2	13.3 73.8	11.1 61.9
12	10.5	3.5	6	4.5	20	40	M 3×12	6 260	8 330	51.6	44.7 237	37.5 199
15	15	4.5	8	6	30	60	M 4×16	11 600	13 400	112	95.6 556	95.6 556
20	18	6	9.5	8.5	30	60	M 5×18	18 100	21 100	232	195 1 090	195 1 090
23	22	7	11	9	30	60	M 6×22	24 100	31 700	349	421 2 140	421 2 140
								25 200	28 800	362	309 1 690	309 1 690
28	25	9	14	12	40	80	M 8×28	30 800	38 300	483	533 2 740	533 2 740
								35 400	40 700	623	536 2 820	536 2 820
34	28	9	14	12	40	80	M 8×28	42 700	53 200	814	894 4 460	894 4 460
								48 700	53 700	823	631 3 480	579 3 190
45	34	14	20	17	52.5	105	M12×35	59 500	71 600	1 100	1 090 5 570	1 000 5 110
								74 600	80 200	1 610	1 150 6 190	1 060 5 690
								95 200	114 000	2 280	2 240 11 100	2 050 10 200

Note<sup>(1)</sup>: Track rail lengths L are shown in Table 11.1 and 11.2 on page A-52 and A-53.  
<sup>(2)</sup>: Track rail mounting bolts are not appended. Hexagon socket bolts of JIS B 1176 strength division 12.9 or equivalent are recommended.  
<sup>(3)</sup>: The directions of basic dynamic load rating (C), basic static load rating (C<sub>0</sub>) and static moment rating (T<sub>0</sub>, T<sub>x</sub> and T<sub>y</sub>) are shown in the sketches below. The upper values in the T<sub>x</sub> and T<sub>y</sub> column apply to one slide unit, and the lower values apply to two units in close contact.  
<sup>(4)</sup>: MHT8...SL, MHT10...SL, MHT12 and MHT12...SL can be mounted also from bottom direction.  
 Remark 1: The mark ☆ indicates that interchangeable specification products are available.  
 2: For dimensions of grease nipple and oil hole, see page 99.  
 3: Oil hole is provided for size 8 and 10 models.

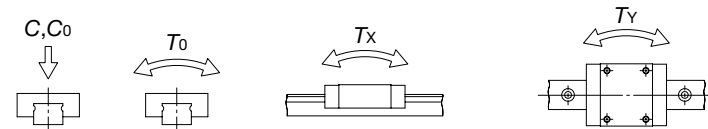

Example of identification number of assembled set (For details, see "Identification number and specification".)

**MHT G 20 C2 R480 T<sub>1</sub> P S2 /D**

- Length of slide unit**: Standard: No symbol, High rigidity long: G
- Size**: 8, 10, 12, 15, 20, 25, 30, 35, 45
- Length of track rail (480mm)**
- Preload amount**: Clearance: T<sub>0</sub>, Standard: No symbol, Light preload: T<sub>1</sub>, Medium preload: T<sub>2</sub>, Heavy preload: T<sub>3</sub>
- Material**: High carbon steel: No symbol, Stainless steel: SL
- Accuracy class**: High: H, Precision: P, Super precision: SP
- Interchangeable code**: Interchangeable specification: S2, Non interchangeable specification: No symbol
- Special specification**: A, D, E, F, I, J, L, LF, MA, MN, N, PS, T, V, W, Z
- Series**: Flange type, mounting from bottom: MHT
- Number of slide unit (two slide units)**

※ In case ordering track rail only, model code is changed as shown below.  
 Track rail of interchangeable MHT → Model code LWH (Ex: LWH20R480BPS2)

Block type, mounting from top  
**MHDC**  
**MHD**  
**MHDG**

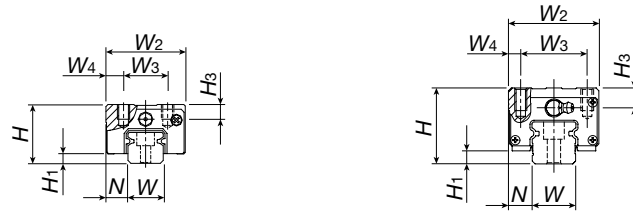

MHDC (C,G) 8...SL  
 MHD (C,G) 10...SL  
 MHD (C,G) 12...SL  
 MHD 12

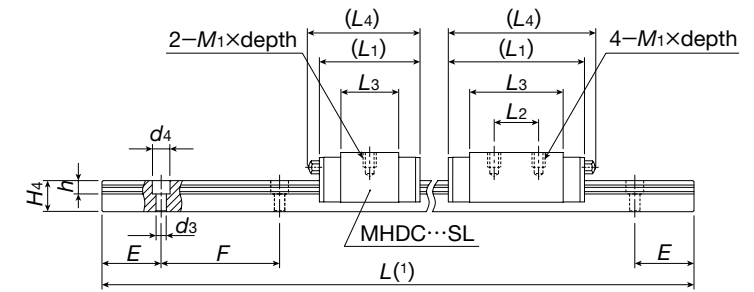

Model number	Interchangeable	Mass (Reference)		Dimension of assembly mm			Dimensions of slide unit mm							
		Slide unit kg	Track rail kg/m	H	H <sub>1</sub>	N	W <sub>2</sub>	W <sub>3</sub>	W <sub>4</sub>	L <sub>1</sub>	L <sub>2</sub>	L <sub>3</sub>	L <sub>4</sub>	M <sub>1</sub> ×depth
MHDC 8...SL	☆	0.008	0.32	11	2.1	4	16	10	3	18	—	9.0	—	M 2 × 2.5
MHD 8...SL	☆	0.013								24	10	15.3		
MHDG 8...SL	☆	0.018								30.5	21.7			
MHDC 10...SL	☆	0.018	0.47	13	2.4	5	20	13	3.5	24	—	13.4	—	M 2.6 × 3
MHD 10...SL	☆	0.026								32	12	21.4		
MHDG 10...SL	☆	0.035								40	29.4			
MHDC 12...SL	☆	0.057	0.86	20	3.2	7.5	27	15	6	34	—	19.6	38	M 4 × 5
MHD 12	☆	0.089								46	15	31.6	50	
MHDG 12...SL	☆	0.115								58	43.6	62		
MHD 15	☆	0.23	1.47	28	4.5	9.5	34	26	4	66	26	44.2	69	M 4 × 10
MHD 25	☆	0.64	3.50	40	6.5	12.5	48	35	6.5	95	35	63.9	106	M 6 × 12
MHDG 25	☆	0.78								118	50	86.6	129	
MHD 30	☆	1.12	4.82	45	7	16	60	40	10	113	40	80.6	124	M 8 × 16
MHDG 30	☆	1.44								139	60	106.6	150	
MHD 35	☆	1.74	6.85	55	8	18	70	50	10	123	50	86.2	135	M 8 × 16
MHDG 35	☆	2.26								151	72	114	163	
MHD 45	☆	3.30	10.7	70	10	20.5	86	60	13	147	60	103.4	158	M10 × 20
MHDG 45	☆	4.57								190	80	146.6	201	

H <sub>3</sub>	Dimensions of track rail mm							Recommended mounting bolt for track rail <sup>(2)</sup> mm Bolt size x length	Basic dynamic load rating <sup>(3)</sup> C N	Basic static load rating <sup>(3)</sup> C <sub>0</sub> N	Static moment rating <sup>(3)</sup>		
	W	H <sub>4</sub>	d <sub>3</sub>	d <sub>4</sub>	h	E	F				T <sub>0</sub> N·m	T <sub>X</sub> N·m	T <sub>Y</sub> N·m
3	8	6	2.4	4.2	2.3	10	20	M 2 × 8	1 050	1 270	5.3	2.2 15.5	1.8 13.0
									1 510	2 120	8.8	4.7 32.0	4.7 26.9
									1 910	2 970	12.3	8.8 55.4	8.8 46.4
3.5	10	7	3.5	6	3.5	12.5	25	M 3 × 8	1 920	2 350	12.2	4.8 37.1	4.8 31.2
									2 640	3 700	19.2	11.3 73.8	11.1 61.9
									3 280	5 050	26.2	20.0 123	20.0 103
5	12	10.5	3.5	6	4.5	20	40	M 3 × 12	4 560	5 300	32.8	19.4 117	16.3 98.5
									6 260	8 330	51.6	44.7 237	37.5 199
									7 780	11 400	70.4	80.4 399	67.5 335
8.5	15	15	4.5	8	6	30	60	M 4 × 16	11 600	13 400	112	95.6 556	95.6 556
10.5	23	22	7	11	9	30	60	M 6 × 22	25 200	28 800	362	309 1 690	309 1 690
									30 800	38 300	483	533 2 740	533 2 740
11	28	25	9	14	12	40	80	M 8 × 28	35 400	40 700	623	536 2 820	536 2 820
									42 700	53 200	814	894 4 460	894 4 460
17	34	28	9	14	12	40	80	M 8 × 28	48 700	53 700	823	631 3 480	579 3 190
									59 500	71 600	1 100	1 090 5 570	1 000 5 110
23	45	34	14	20	17	52.5	105	M12 × 35	74 600	80 200	1 610	1 150 6 190	1 060 5 690
									95 200	114 000	2 280	2 240 11 100	2 050 10 200

Note(1) : Track rail lengths L are shown in Table 11.1 and 11.2 on page A-52 and A-53.  
 (2) : Track rail mounting bolts are not appended. Hexagon socket bolts of JIS B 1176 strength division 12.9 or equivalent are recommended.  
 (3) : The directions of basic dynamic load rating (C), basic static load rating (C<sub>0</sub>) and static moment rating (T<sub>0</sub>, T<sub>X</sub> and T<sub>Y</sub>) are shown in the sketches below. The upper values in the T<sub>X</sub> and T<sub>Y</sub> column apply to one slide unit, and the lower values apply to two units in close contact.  
 Remark 1 : The mark ☆ indicates that interchangeable specification products are available.  
 2 : For dimensions of grease nipple and oil hole, see page 99.  
 3 : Oil hole is provided for size 8 and 10 models.

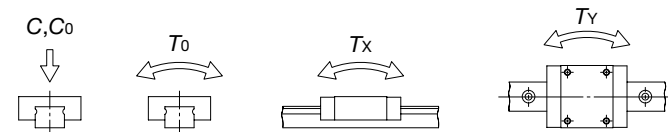

Example of identification number of assembled set (For details, see "Identification number and specification".)

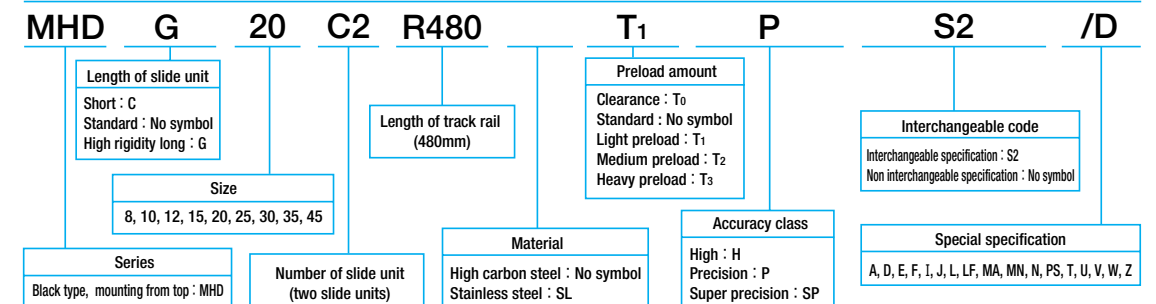

※ In case ordering track rail only, model code is changed as shown below.  
 Track rail of interchangeable MHD → Model code LWH (Ex:LWH20R480BPS2)



Compact block type, mounting from top  
**MHS**  
**MHSG**

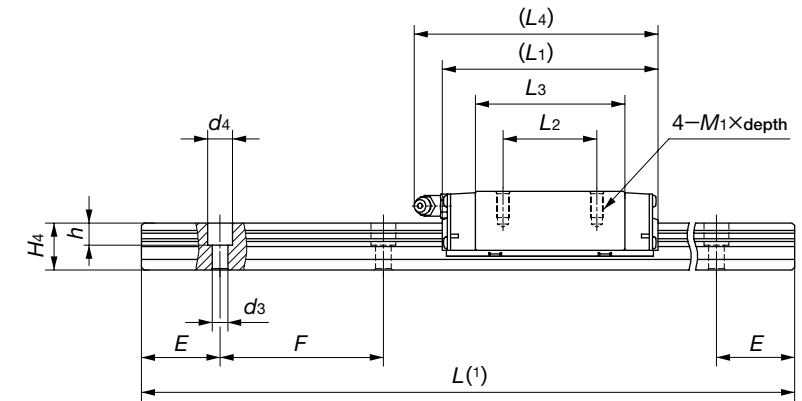
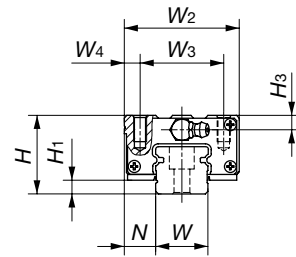

Model number	Interchangeable	Mass (Reference)		Dimension of assembly mm			Dimension of slide unit mm							
		Slide unit kg	Track rail kg/m	H	H <sub>1</sub>	N	W <sub>2</sub>	W <sub>3</sub>	W <sub>4</sub>	L <sub>1</sub>	L <sub>2</sub>	L <sub>3</sub>	L <sub>4</sub>	M1×depth
<b>MHS 15</b>	☆	0.18	1.47	24	4.5	9.5	34	26	4	66	26	44.2	69	M4×8
<b>MHS 20</b>	☆	0.35	2.56	30	5	12	44	32	6	83	36	56	95	M5×10
<b>MHSG 20</b>	☆	0.52								112	50	84.8	124	
<b>MHS 25</b>	☆	0.54	3.50	36	6.5	12.5	48	35	6.5	95	35	63.9	106	M6×12
<b>MHSG 25</b>	☆	0.66								118	50	86.6	129	
<b>MHS 30</b>	☆	1.00	4.82	42	7	16	60	40	10	113	40	80.6	124	M8×16
<b>MHSG 30</b>	☆	1.29								139	60	106.6	150	

H <sub>3</sub>	Dimension of track rail mm								Recommended mounting bolt for track rail <sup>(2)</sup> mm Bolt size x length	Basic dynamic load rating <sup>(3)</sup> C N	Basic static load rating <sup>(3)</sup> C <sub>0</sub> N	Static moment rating <sup>(3)</sup>		
	W	H <sub>4</sub>	d <sub>3</sub>	d <sub>4</sub>	h	E	F	T <sub>0</sub> N·m				T <sub>X</sub> N·m	T <sub>Y</sub> N·m	
4.5	15	15	4.5	8	6	30	60	M4×16	11 600	13 400	112	95.6 556	95.6 556	
5.5	20	18	6	9.5	8.5	30	60	M5×18	18 100	21 100	232	195 1 090	195 1 090	
									24 100	31 700	349	421 2 140	421 2 140	
6.5	23	22	7	11	9	30	60	M6×22	25 200	28 800	362	309 1 690	309 1 690	
									30 800	38 300	483	533 2 740	533 2 740	
8	28	25	9	14	12	40	80	M8×28	35 400	40 700	623	536 2 820	536 2 820	
									42 700	53 200	814	894 4 460	894 4 460	

Note(1) : Track rail lengths L are shown in Table 11.1 on page A-52.  
 (2) : Track rail mounting bolts are not appended. Hexagon socket bolts of JIS B 1176 strength division 12.9 or equivalent are recommended.  
 (3) : The directions of basic dynamic load rating (C), basic static load rating (C<sub>0</sub>) and static moment rating (T<sub>0</sub>, T<sub>X</sub> and T<sub>Y</sub>) are shown in the sketches below. The upper values in the T<sub>X</sub> and T<sub>Y</sub> column apply to one slide unit, and the lower values apply to two units in close contact.  
 Remark 1 : The mark ☆ indicates that the combination is available for also interchangeable specification.  
 2 : For the shape of grease nipple, see page 99.

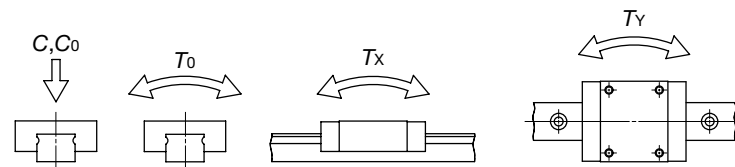

Example of identification number for assembled set (For details, see "Identification number and specification".)

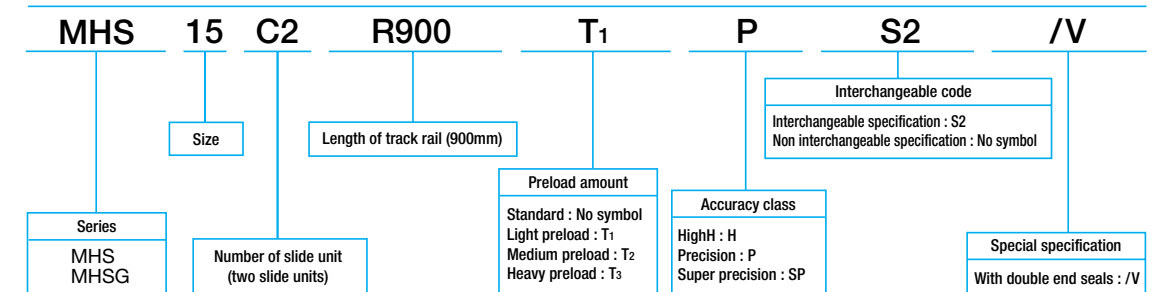

※ In case ordering track rail only, model code is changed as shown below.  
 Track rail of interchangeable MHS → Model code LWH (Ex: LWH15R900BPS2)

# C-Lube Linear Way MUL

**IKO C-Lube Linear Way MUL** is a linear motion rolling guide, incorporating the C-Lube as a components part for lubrication in the slide unit of miniature type Linear Way LWUL series to achieve maintenance free operations for a long period of time.

## Long-term maintenance free

The lubricant in the C-Lube keeps the lubrication performance for a long period of time and achieves long-term maintenance free operations. (5 years and 20,000km)  
So man-hours for troublesome lubrication control can be reduced.

## Lightweight and compact

The C-Lube is incorporated in the lightweight and compact slide unit of miniature type Linear Way LWLU series without changing the external dimensions of the slide unit.

## Smooth and light motion

As the C-Lube is not in contact with the track rail, frictional resistance does not increase. A smooth and light motion is ensured.

## Stainless Steel

The metal components are manufactured from corrosion resistant stainless steel. So this series is most suitable for use in clean rooms and also for applications where the use of lubricants and rust preventive oil should be avoided or kept to a minimum.

## U-shaped track rail

Rigidity of track rail under moment and torsion is very much increased by adopting the U-shaped design. The track rail can, therefore, be mounted on machines and equipment as structural members, either in a cantilever position or supported at both ends, so they can be combined an assembled freely.

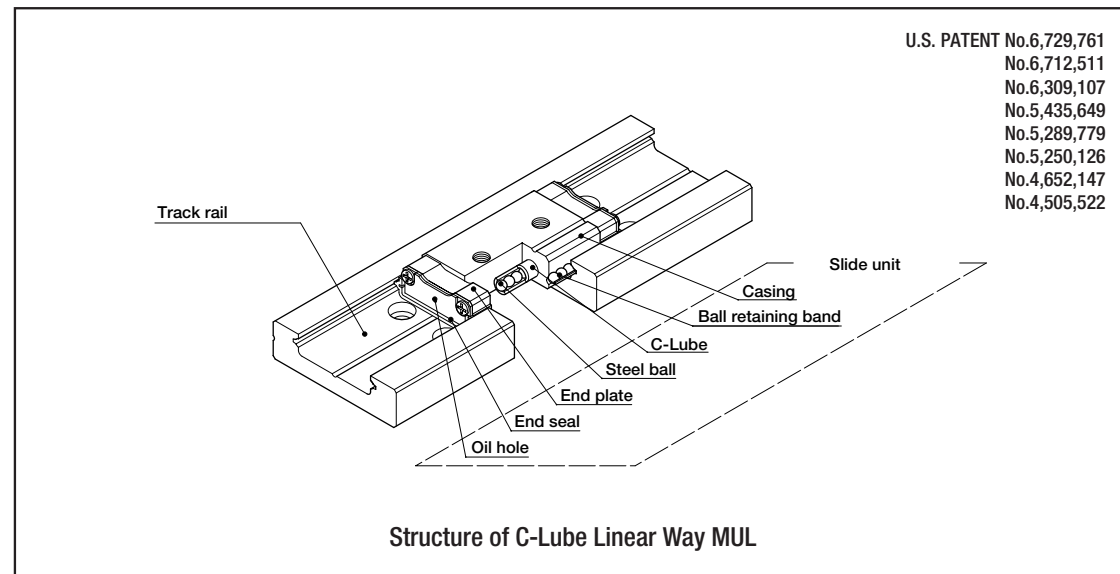

## IKO C-Lube Linear Way MUL

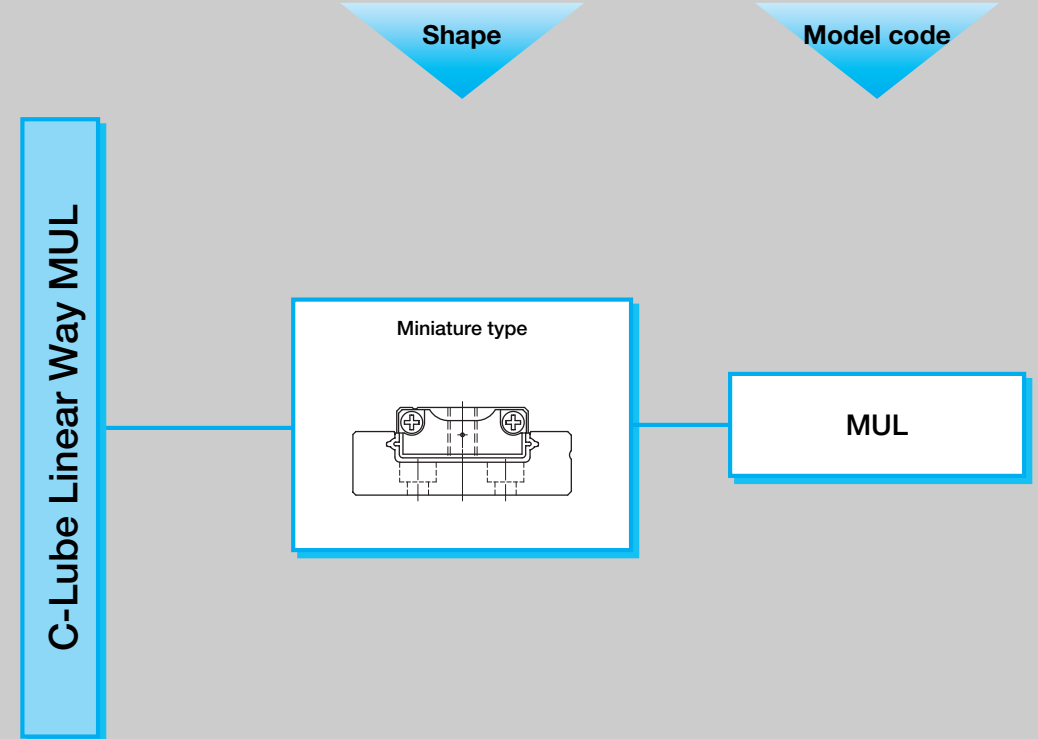

## ● Identification number and specification

The specification of C-Lube Linear Way MUL is indicated by the identification number, consisting of a model code, a size, a part code, a preload symbol, a classification symbol and any supplemental codes. For details of each specification, see page 78.

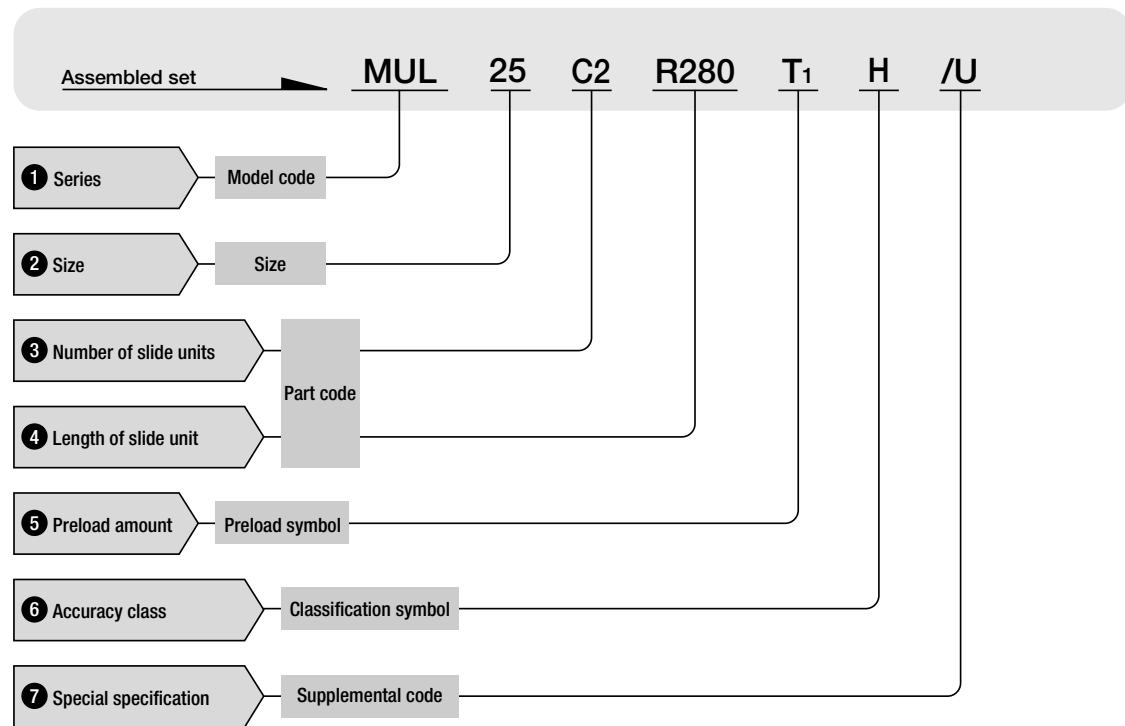

<b>1 Series</b>	Miniature type : <b>MUL</b>												
<b>2 Size</b>		Applicable type and size of slide unit are shown in Table 1.											
<table border="1"> <caption>Table 1 Type and size of C-Lube Linear Way MUL</caption> <thead> <tr> <th rowspan="2">Size</th> <th>Type</th> <th>Stainless steel</th> </tr> <tr> <th></th> <th>MUL</th> </tr> </thead> <tbody> <tr> <td>25</td> <td></td> <td>○</td> </tr> <tr> <td>30</td> <td></td> <td>○</td> </tr> </tbody> </table>			Size	Type	Stainless steel		MUL	25		○	30		○
Size	Type	Stainless steel											
		MUL											
25		○											
30		○											
<b>3 Number of slide unit</b>	: C○	For an assembled set, indicate the number of slide units assembled on one track rail.											
<b>4 Length of track rail</b>	: R○	Indicate the length of track rail in mm. For standard and maximum lengths, see "Track rail length" on page A-67.											
<b>5 Preload amount</b>	Standard : No symbol Light preload : T1	For detail of preload amount, see page 86.											
<b>6 Accuracy class</b>	Ordinary class : No symbol High class : H	For detail of accuracy, see page 81.											
<b>7 Special specifications</b>		Applicable special specifications are shown in Table 2. When a combination of several special specifications is required, please refer Table 3 and arrange their supplemental codes in alphabetical order. For detail of specifications, see page 88.											

Table 2 Applicable special specifications

Specifications	Supplemental code	Dimension
Specified rail mounting hole positions	E	
Black chrome surface treatment on track rail	LR	
With track rail mounting bolts	MA	See Table 4.
With upper seals	U	See Table 5.
Matched sets to be used as an assembled group	W	

Table 3 Combination of special specifications

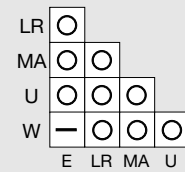

Remark : When a combination of several special specifications is required, arrange their supplemental codes in alphabetical order.

Table 4 Size for track rail mounting bolt (Supplemental code /MA)

Model code	Bolt size
<b>MUL 25</b>	Cross-recessed head cap screw for precision equipment M2.5×6
<b>MUL 30</b>	Hexagon socket head bolt (1) M2.5×6

Note(1) : The property division A2-70 of JIS B 1176 hexagon socket head bolt is recommended.

Table 5 Dimension of slide unit with upper seals (Supplemental code: /U)

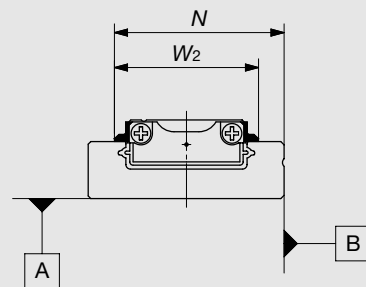

unit : mm

Model number	N	W <sub>2</sub>
<b>MUL 25</b>	21.4	18
<b>MUL 30</b>	25.9	22

## Track rail length

Standard and maximum lengths of track rail are shown in Table 6. Track rail in any lengths are also available. Simply indicate the necessary length of track rail in millimeter (mm) in the identification number. For the tolerance of E dimensions and track rail length, consult **IKO** for further information.

- E dimensions at both ends are the same unless otherwise specified. To change these dimensions, specify the specified rail mounting hole positions (supplemental code "/E") of special specification. Please see page 91.

Table 6 Standard and maximum lengths of track rails

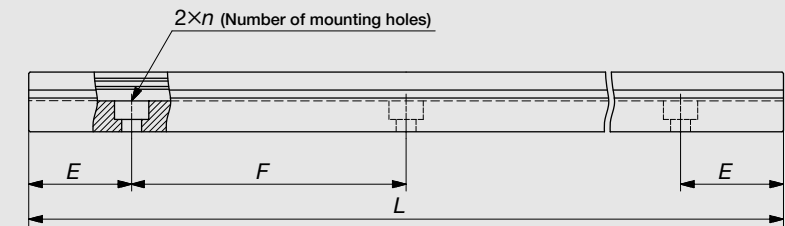

unit : mm

Model number		<b>MUL 25</b>	<b>MUL 30</b>
Item	Standard length L (n)	105(3)	120(3)
		140(4)	160(4)
		175(5)	200(5)
		210(6)	240(6)
		245(7)	280(7)
		280(8)	320(8)
Mounting hole pitch F		35	40
E		17.5	20
Reference dimension E	Over (Incl.)	4.5	4.5
	Under	22	24.5
Maximum length (1)		420 (840)	480 (960)

Note (1) : The track rails can be manufactured up to the maximum length shown in parentheses. If required, please consult **IKO**.

## Geometrical moment of inertia

High rigidity design of C-Lube Linear Way MUL is achieved by adopting a U-shaped track rail. Table 7 shows the moment of inertia of sectional area of track rails.

Table 7 Moment of inertia of sectional area of track rails

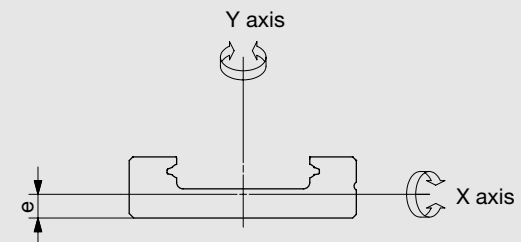

Model number	Moment of inertia of sectional area mm <sup>4</sup>		Center of gravity e mm
	I <sub>x</sub>	I <sub>y</sub>	
<b>MUL 25</b>	3.7 × 10 <sup>2</sup>	7.5 × 10 <sup>3</sup>	2.6
<b>MUL 30</b>	9.3 × 10 <sup>2</sup>	1.7 × 10 <sup>4</sup>	3.3

1N=0.102kgf=0.2248lbs.  
1mm=0.03937inch

## MUL

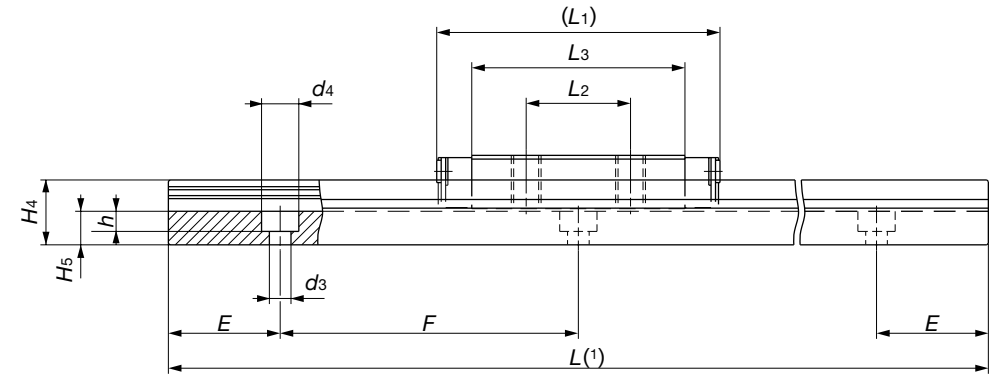
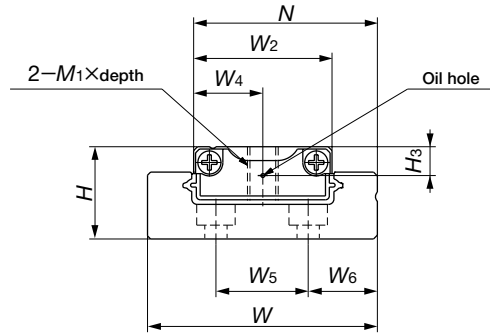

Model number	Mass (Reference) g		Dimension of assembly mm		Dimension of slide unit mm								W	H4
	Slide unit	Track rail (per 100mm)	H	N	W2	W4	L1	L2	L3	M1×depth	H3			
<b>MUL 25</b>	13	87	9	19.4	14	7	31	12	22	M3×5	2.9	24.9	6.7	
<b>MUL 30</b>	28	139	12	23.9	18	9	38	14	28.6	M4×7	3.75	29.9	8.7	

Dimension of track rail mm								Appended mounting bolt for track rail <sup>(2)</sup> mm Bolt size x length	Basic dynamic load rating <sup>(3)</sup> C N	Basic static load rating <sup>(3)</sup> Co N	Static moment rating <sup>(3)</sup>		
H5	W5	W6	d3	d4	h	E	F				To N·m	Tx N·m	Ty N·m
3.2	9	8	2.9	4.8	1.6	17.5	35	Cross-recessed head cap screw for precision equipment M2.5×6	1 770	2 840	20.3	10.1 53.7	8.4 45.0
4.5	12	9	2.9	5	2.7	20	40	Hexagon socket head bolt M2.5×6	2 280	3 810	34.9	16.9 87.5	14.2 73.4

Note<sup>(1)</sup> : Track rail lengths  $L$  are shown in Table 6 on page A-68.  
<sup>(2)</sup> : Track rail mounting bolts are not appended. For recommended bolts, see Table 4 on page A-57.  
<sup>(3)</sup> : The directions of basic dynamic load rating (C), basic static load rating (Co) and static moment rating (To, Tx and Ty) are shown in the sketches below. The upper values in the Tx and Ty column apply to one slide unit, and the lower values apply to two units in close contact.  
 Remark : For the dimension of oil hole, please see page 99.

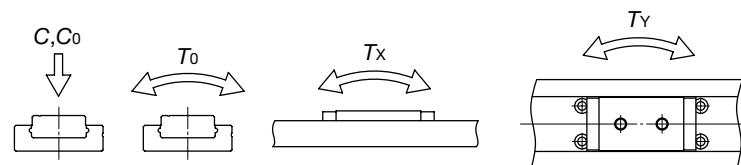

Example of identification number (For details, see "Identification number and specification".)

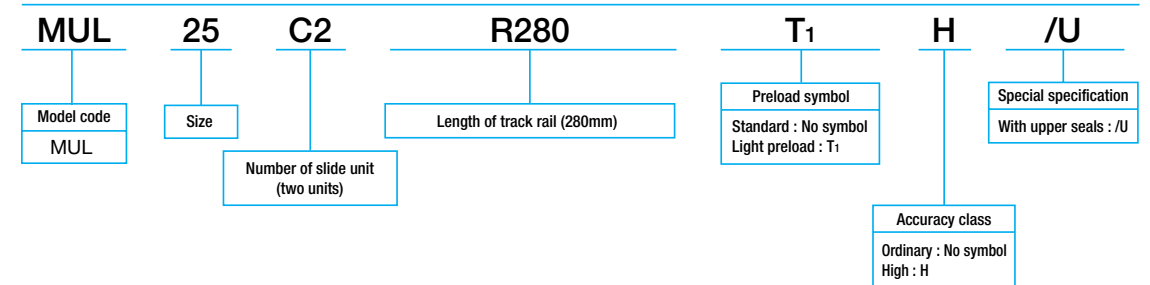

# C-Lube Linear Roller Way Super MX

## MX/MXD/MXS/MXN/MXNS

**IKO C-Lube Linear Roller Way Super MX** is a high performance roller type linear motion rolling guide, featuring high reliability, high rigidity, high accuracy and smooth motion which are required from machine tools, semiconductor manufacturing and liquid crystal manufacturing equipments. Cylindrical rollers are incorporated as rolling elements in four rows, arranged in parallel to each other. Owing to its small elastic deformation, stable operation is ensured even under heavy or fluctuating loads. This series is also suitable for applications with vibration and shocks.

With **IKO** original C-Lube technology, its performance makes us different from others, providing superior cost performance for your machines. Maintenance free for 20,000km or 5 years minimizes the amount of lubricant required and contributes to the global environment protection.

### Super high rigidity

Rigidity of linear motion rolling guide has a large influence to the performance of machines or equipment in which they are assembled.

Very high rigidity of C-Lube Linear Roller Way Super MX is achieved owing to the excellent elastic deformation characteristics of cylindrical rollers which give smaller elastic deformation under load as compared with steel balls. In addition, a large number of cylindrical rollers are incorporated in the slide unit.

### Accurate positioning with excellent friction characteristics

As compared with the slide guides and ball type linear motion rolling guides, roller type has superior frictional characteristics and gives lower frictional resistance under preload. Good response to micro feeding and high positioning accuracy can thus be achieved.

### Excellent vibration damping characteristics

As compared with ball types in the same size, C-Lube Linear Roller Way Super MX has higher rigidity and gives much smaller deformation value under repeated fluctuating load. The natural frequency is high, and the vibration damping time can be very short.

### Maintenance free for saving-resources

Maintenance free has the ability to maintain lubrication for a long time, reducing the amount of labor required for troublesome lubrication maintenance. The capillary lubrication body continuously supplies lubricant for long period of time even after original grease inside is completely exhausted.

### Interchangeability among types of slide unit

Various types of slide units with different sectional shapes and lengths are prepared. All of these slide units can be mounted on the same track rails freely as required.

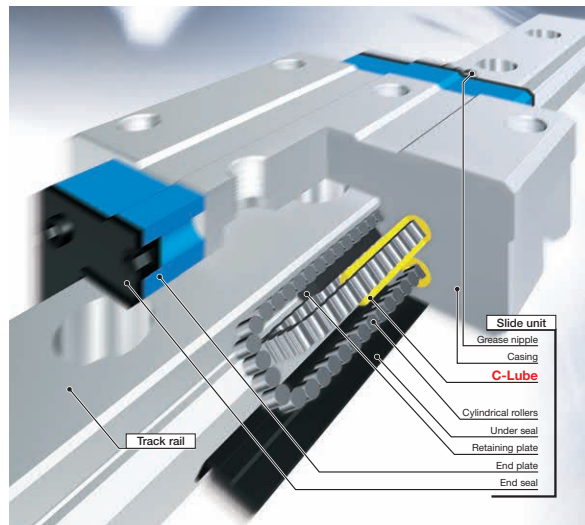

Structure of C-Lube Linear Roller Way Super MX

U.S. PATENT No. 5,800,064  
 No. 5,193,914  
 No. 5,564,188  
 No. 5,374,126  
 No. 5,622,433  
 No. 6,176,617  
 No. 5,967,667  
 No. 5,464,288

## C-Lube Linear Roller Way Super MX series

C-Lube Linear Roller Way Super MX

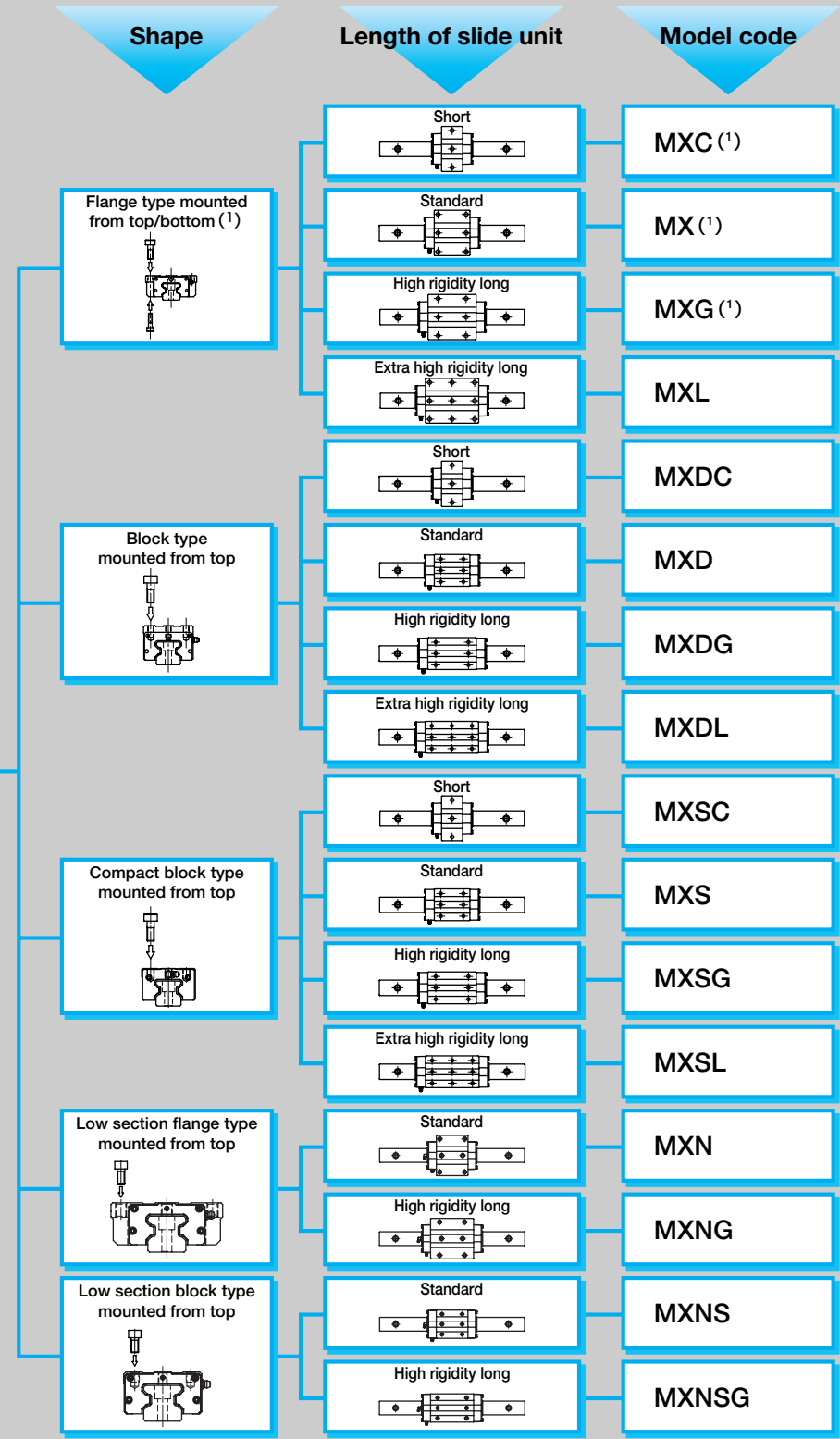

Note(1) : Size 20 (MX20, MXD20 and MXS20) can be mounted from top only.  
 For mounting from bottom, MXH can be used, which have the same dimensions as those of above models.

A

MX, MXD, MXS, MXN, MXNS

## Identification number

The specification of C-Lube Linear Roller Way Super MX is identified by the identification number, which consists of a model code, a size, a part code, a preload symbol, a classification symbol, interchangeable code and optional supplemental codes.

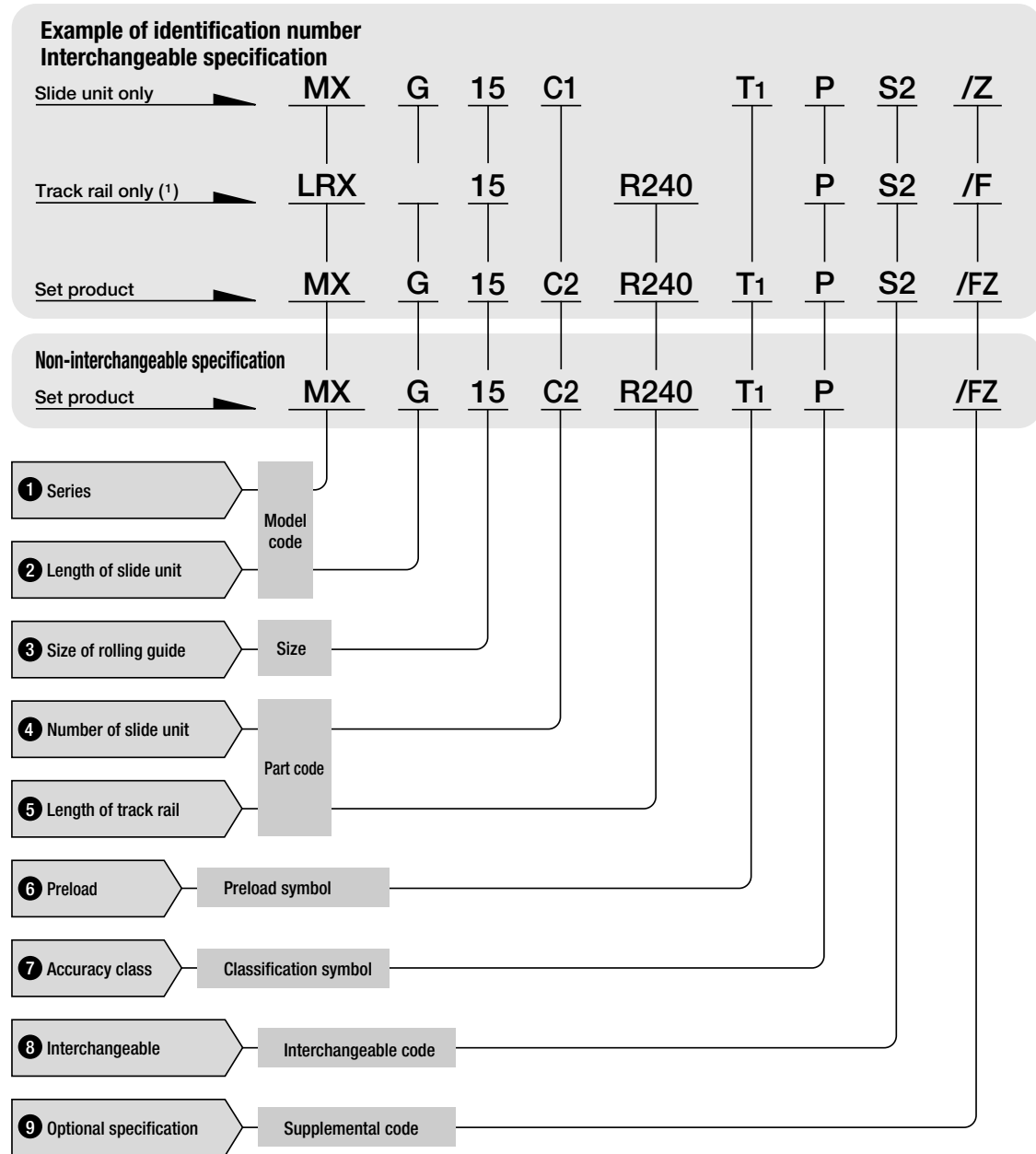

Note(1) : In case ordering track rail only, model code should be changed as shown below.  
 MX / MXD / MXS → LRX (Ex: LRX15R240HS2)

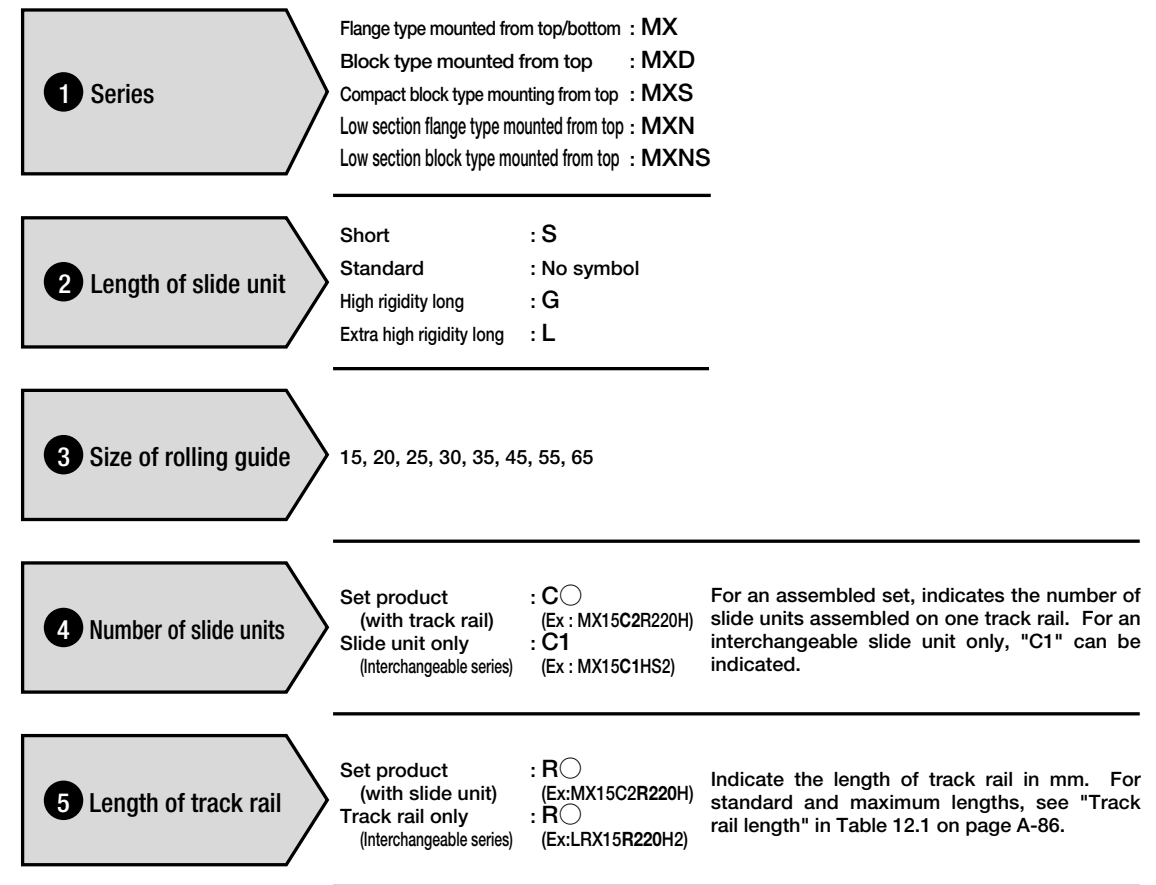

**Table 1.1 Type and size of C-Lube Linear Roller Way Super MX (Flanged shape, mounting from top and bottom)**

Model code	Carbon steel			
	Short MXC	Standard MX	High rigidity long MXG	Extra high rigidity long MXL
15	☆	☆	☆	—
20 (1)	☆	☆	☆	○
25	☆	☆	☆	○
30	☆	☆	☆	○
35	☆	☆	☆	○
45	☆	☆	☆	○
55	☆	☆	☆	—
65	☆	☆	☆	—

Note(1) : MXC20, MX20 and MXG20 can be mounted from top side only.  
 For mounting from bottom, MXH20 and MXHG20 can be used.  
 Remark : ☆ marks are also applicable for interchangeable specification.

A  
MX, MXD, MXS, MXN, MXNS

Table 1.2 Type and size of C-Lube Linear Roller Way Super MX (Blocked shape, mounting from top)

Model code Size	Carbon steel			
	Short MXDC	Standard MXD	High rigidity long MXDG	Extra high rigidity long MXDL
15	☆	☆	☆	—
20	☆	☆	☆	○
25	☆	☆	☆	○
30	☆	☆	☆	○
35	☆	☆	☆	○
45	☆	☆	☆	○
55	☆	☆	☆	—
65	☆	☆	☆	—

Remark : ☆ marks are also applicable for interchangeable specification.

Table 1.3 Type and size of C-Lube Linear Roller Way Super MX (Compact blocked shape, mounting from top)

Model code Size	Carbon steel			
	Short MXSC	Standard MXS	High rigidity long MXSG	Extra high rigidity long MXSL
15	☆	☆	☆	—
20	☆	☆	☆	○
25	☆	☆	☆	○
30	☆	☆	☆	○

Remark : ☆ marks are also applicable for interchangeable specification.

Table 1.4 Type and size of C-Lube Linear Roller Way Super MX (Low section flange type)

Model code Size	Carbon steel	
	Standard MXN	High rigidity long MXNG
35	☆	☆
45	☆	☆
55	☆	☆

Remark : ☆ marks are also applicable for interchangeable specification.

Table 1.5 Type and size of C-Lube Linear Roller Way Super MX (Low section block type)

Model code Size	Carbon steel	
	Standard MXNS	High rigidity long MXNSG
35	☆	☆
45	☆	☆
55	☆	☆

Remark : ☆ marks are also applicable for interchangeable specification.

6 Preload amount

Standard : No symbol  
 Light preload : T1  
 Medium preload : T2  
 Heavy preload : T3

Specify this item for an assembled set or a single slide unit.  
 For applicable preload amount, see Table 2. For details of preload amount, see page 86.

Table 2 Applicable preload class

Model code	Preload class and code			
	Standard (No symbol)	Light preload (T1)	Medium preload (T2)	Heavy preload (T3)
15	☆	☆	☆	○
20	☆	☆	☆	○
25	○	☆	☆	○
30	○	☆	☆	○
35	○	○	☆	☆
45	○	○	☆	☆
55	○	○	☆	☆
65	○	○	☆	☆

Remark : ☆ marks are also applicable for interchangeable specification.

7 Accuracy class

High : H  
 Precision : P  
 Super precision : SP  
 Ultra precision : UP

Super precision class (SP) and Ultra precision class (UP) are applicable to Non-interchangeable products only. In the interchangeable specification, please combine the same accuracy codes on both slide unit and track rail.

Table 3 Applicable accuracy class

Model code	Accuracy class and code			
	High (H)	Precision (P)	Super precision (SP)	Ultra precision (UP)
15	☆	☆	○	○
20	☆	☆	○	○
25	☆	☆	○	○
30	☆	☆	○	○
35	☆	☆	○	○
45	☆	☆	○	○
55	☆	☆	○	○
65	☆	☆	○	○

Remark : ☆ marks are also applicable for interchangeable specification.

8 Interchangeable specification

Interchangeable : S2

In C-Lube Linear Roller Way, slide unit and track rail can be supplied separately by indicating interchangeable code S2.

9 Special specification

For applicable special specifications, see Table 4. When several special specifications are combined, see Table 5. For details of special specifications, see page 86.





Table 7.2 Female threads for bellows (Supplemental code /J, /JJ)  
Flange type, size 35, 45, 55 and 65

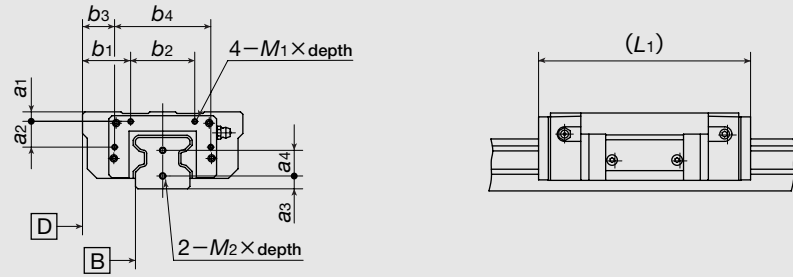

unit : mm

Model number	Slide unit							Track rail			
	a1	a2	b1	b2	b3	b4	M1×depth	L1 <sup>(1)</sup>	a3	a4	M2×depth
<b>MXC 35</b>	6	16	30	40	20	60	M3×6	99	8	16	M4×8
<b>MX 35</b>								131			
<b>MXG 35</b>								159			
<b>MXL 35</b>								191			
<b>MXC 45</b>	7	21	35	50	23	74	M4×8	123	10	19	M5×10
<b>MX 45</b>								163			
<b>MXG 45</b>								203			
<b>MXL 45</b>								243			
<b>MXC 55</b>	7	27	40	60	26	88	M4×8	145	10	24	M5×10
<b>MX 55</b>								193			
<b>MXG 55</b>								247			
<b>MXL 55</b>								285			
<b>MXC 65</b>	8.7	37	47.5	75	31	108	M5×10	191	14	28	M6×12
<b>MX 65</b>								255			
<b>MXG 65</b>								319			

Note<sup>(1)</sup> : L1 is the total length for the slide unit with female threads for bellows at both ends.

Table 7.3 Female threads for bellows (Supplemental code /J, /JJ)  
Block type, size 15, 20, 25 and 30

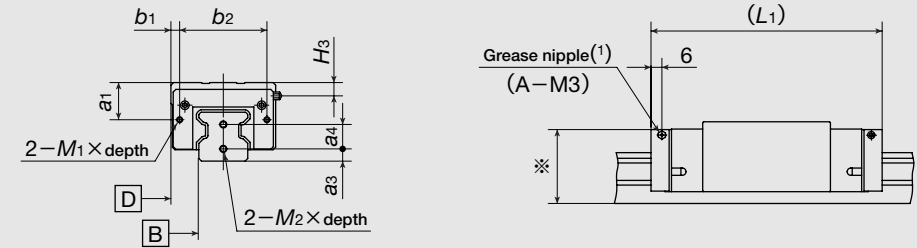

unit : mm

Model number	Slide unit					Track rail			
	a1	b1	b2	M1×depth	L1 <sup>(2)</sup>	H3	a3	a4	M2×depth
<b>MXDC 15</b>	14.5	4	26	M3×6	67	5	4	8	M3×6
<b>MXD 15</b>					83				
<b>MXDG 15</b>					99				
<b>MXSC 15</b>					67				
<b>MXS 15</b>	10.5	4	26	M3×6	83	1	4	8	M3×6
<b>MXSG 15</b>					99				
<b>MXDC 20</b>					81				
<b>MXD 20</b>	16	4	36	M3×6	101	6	5	10	M4×8
<b>MXDG 20</b>					121				
<b>MXDL 20</b>					143				
<b>MXSC 20</b>					81				
<b>MXS 20</b>	12	4	36	M3×6	101	2	5	10	M4×8
<b>MXSG 20</b>					121				
<b>MXSL 20</b>					143				
<b>MXDC 25</b>					89				
<b>MXD 25</b>	19.5	4	40	M3×6	113	8	6	12	M4×8
<b>MXDG 25</b>					128				
<b>MXDL 25</b>					152				
<b>MXSC 25</b>					89				
<b>MXS 25</b>	15.5	4	40	M3×6	113	4	6	12	M4×8
<b>MXSG 25</b>					128				
<b>MXSL 25</b>					152				
<b>MXDC 30</b>					100				
<b>MXD 30</b>	21.5	5	50	M3×6	128	7.8	7	14	M4×8
<b>MXDG 30</b>					149				
<b>MXDL 30</b>					177				
<b>MXSC 30</b>					100				
<b>MXS 30</b>	18.5	5	50	M3×6	128	4.8	7	14	M4×8
<b>MXSG 30</b>					149				
<b>MXSL 30</b>					177				
<b>MXDC 30</b>					100				

Note<sup>(1)</sup> : The specification and mounting position if grease nipple are different from those of the standard product. A-M4 is the grease nipple for size 30. For specification of grease nipple, refer page 102.

<sup>(2)</sup> : L1 is the total length for the slide unit with female threads for bellows at both ends.

Remarks 1 : The table shows representative model numbers only and is also applicable to same model of stainless series.

2 : For the size 15 and 20, the dimension ※ is higher than the dimension H. For details, consult IJKO for future information.

Table 7.4 Female threads for bellows (Supplemental code /J, /JJ)  
Block type, size 35, 45, 55 and 65

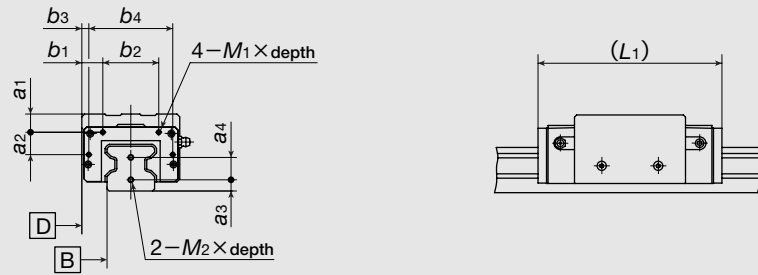

unit : mm

Model number	Slide unit							Track rail			
	a1	a2	b1	b2	b3	b4	M1×depth	L1 <sup>(1)</sup>	a3	a4	M2×depth
<b>MXDC 35</b>	13	16	15	40	5	60	M3×6	99	8	16	M4×8
<b>MXD 35</b>								131			
<b>MXDG 35</b>								159			
<b>MXDL 35</b>								191			
<b>MXDC 45</b>	17	21	18	50	6	74	M4×8	123	10	19	M5×10
<b>MXD 45</b>								163			
<b>MXDG 45</b>								203			
<b>MXDL 45</b>								243			
<b>MXDC 55</b>	17	27	20	60	6	88	M4×8	145	24	24	M5×10
<b>MXD 55</b>								193			
<b>MXDG 55</b>								247			
<b>MXDL 55</b>								247			
<b>MXDC 65</b>	8.7	37	25.5	75	9	108	M5×10	191	14	28	M6×12
<b>MXD 65</b>								255			
<b>MXDG 65</b>								319			

Note(1) : L1 is the total length for the slide unit with female threads for bellows at both ends.

Table 7.5 Female threads for bellows (Supplemental code /J, /JJ)  
Low section flange type, size 35, 45 and 55

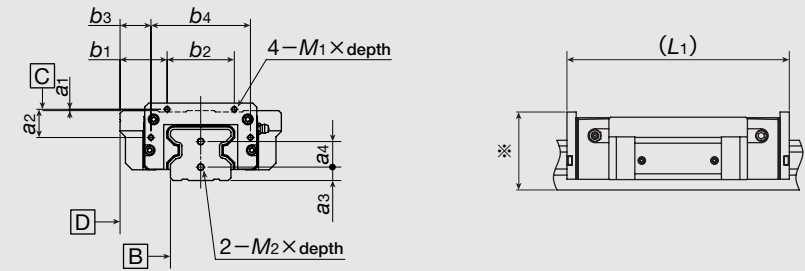

unit : mm

Model number	Slide unit							Track rail			
	a1 <sup>(1)</sup>	a2	b1	b2	b3	b4	M1×depth	L1 <sup>(2)</sup>	a3	a4	M2×depth
<b>MXN 35</b>	2	16	30	40	20	60	M3×6	131	8	16	M4×8
<b>MXNG 35</b>								159			
<b>MXN 45</b>	1	21	35	50	23	74	M4×8	163	10	19	M5×10
<b>MXNG 45</b>								203			
<b>MXN 55</b>								193			
<b>MXNG 55</b>	0	27	40	60	26	88	M4×8	247	24	24	M5×10

Note(1) : Dimension a1 shows gap between mounting surface C and female thread.

(2) : Table shows the total length for the slide unit with female threads for bellows at the both ends.

Remark : Dimension \* is higher than the dimension H. For detail, consult IJKO for future information.

Table 7.6 Female threads for bellows (Supplemental code /J, /JJ)  
Low section block type, size 35, 45 and 55

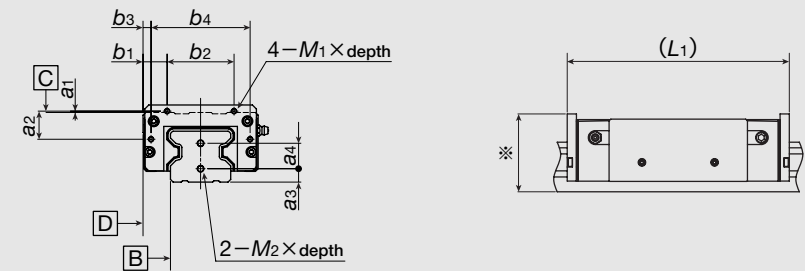

unit : mm

Model number	Slide unit							Track rail			
	a1 <sup>(1)</sup>	a2	b1	b2	b3	b4	M1×depth	L1 <sup>(2)</sup>	a3	a4	M2×depth
<b>MXNS 35</b>	2	16	15	40	5	60	M3×6	131	8	16	M4×8
<b>MXNSG35</b>								159			
<b>MXNS 45</b>	1	21	18	50	6	74	M4×8	163	10	19	M5×10
<b>MXNSG45</b>								203			
<b>MXNS 55</b>								193			
<b>MXNSG55</b>	0	27	20	60	6	88	M4×8	247	24	24	M5×10

Note(1) : Dimension a1 shows gap between mounting surface C and female thread.

(2) : Table shows the total length for the slide unit with female threads for bellows at the both ends.

Remark : Dimension \* is higher than the dimension H. For detail, consult IJKO for future information.

Table 8 Slide unit with C-Wiper (Supplemental code /RC)

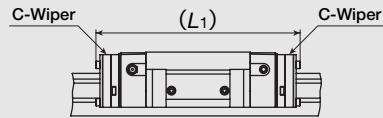

unit : mm

Model number	L1 (1)
<b>MXC 35</b>	123
<b>MX 35</b>	155
<b>MXG 35</b>	183
<b>MXC 45</b>	149
<b>MX 45</b>	189
<b>MXG 45</b>	229
<b>MXC 55</b>	172
<b>MX 55</b>	220
<b>MXG 55</b>	274
<b>MXC 65</b>	223
<b>MX 65</b>	287
<b>MXG 65</b>	351

Note(1) : L1 is the total length for the slide unit with C-Wiper at both ends.  
 Remark : The table shows representative model numbers only and is also applicable to same size of MX.

Table 9.1 Slide unit with double end seals (Supplemental code /V, /VV)  
 Size 15, 20, 25 and 30

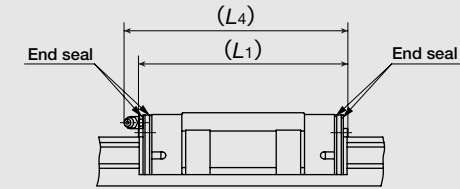

unit : mm

Model number	L1	L4	Model number	L1	L4
<b>MXC 15</b>	58	60	<b>MXC 25</b>	83	92
<b>MX 15</b>	74	76	<b>MX 25</b>	107	116
<b>MXG 15</b>	90	92	<b>MXG 25</b>	122	131
<b>MXC 20</b>	73	83	<b>MXL 25</b>	146	155
<b>MX 20</b>	93	103	<b>MXC 30</b>	93	106
<b>MXG 20</b>	113	123	<b>MX 30</b>	121	134
<b>MXL 20</b>	135	145	<b>MXG 30</b>	142	155
			<b>MXL 30</b>	170	183

Remarks 1 : The table shows representative model numbers only and is also applicable to same size of MX.  
 2 : Table shows the total length for the slide unit with double seals at both ends.

Table 9.2 Slide unit with double end seals (Supplemental code /V, /VV)  
 Size 35, 45, 55 and 65

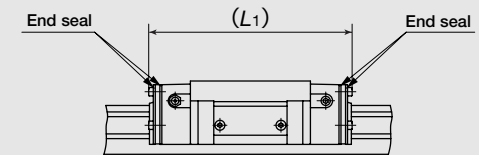

unit : mm

Model number	L1	Model number	L1
<b>MXC 35</b>	101	<b>MXC 55</b>	149
<b>MX 35</b>	133	<b>MX 55</b>	197
<b>MXG 35</b>	161	<b>MXG 55</b>	251
<b>MXL 35</b>	193	<b>MXC 65</b>	192
<b>MXC 45</b>	127	<b>MX 65</b>	256
<b>MX 45</b>	167	<b>MXG 65</b>	320
<b>MXG 45</b>	207		
<b>MXL 45</b>	247		

Remarks 1 : The table shows representative model numbers only and is also applicable to same size of MX.  
 2 : Table shows the total length for the slide unit with double seals at both ends.

Table 10.1 Slide unit with scrapers (Supplemental code /Z, /ZZ)  
Size 15, 20, 25 and 30

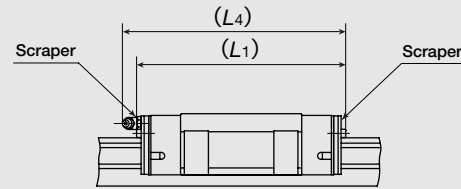

unit : mm

Model number	L1	L4	Model number	L1	L4
<b>MXC 15</b>	60	61	<b>MXC 25</b>	85	93
<b>MX 15</b>	76	77	<b>MX 25</b>	109	117
<b>MXG 15</b>	92	93	<b>MXG 25</b>	124	132
<b>MXC 20</b>	74	83	<b>MXL 25</b>	148	156
<b>MX 20</b>	94	103	<b>MXC 30</b>	96	107
<b>MXG 20</b>	114	123	<b>MX 30</b>	124	135
<b>MXL 20</b>	137	146	<b>MXG 30</b>	145	156
			<b>MXL 30</b>	173	184

Remarks 1 : The table shows representative model numbers only and is also applicable to same size of MX.  
2 : Table shows the total length for the slide unit with scrapers at both ends.

Table 10.2 Slide unit with scrapers (Supplemental code /Z, /ZZ)  
Size 35, 45, 55 and 65

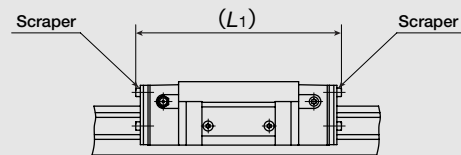

unit : mm

Model number	L1	Model number	L1
<b>MXC 35</b>	103	<b>MXC 55</b>	151
<b>MX 35</b>	135	<b>MX 55</b>	199
<b>MXG 35</b>	163	<b>MXG 55</b>	253
<b>MXL 35</b>	195	<b>MXC 65</b>	194
<b>MXC 45</b>	129	<b>MX 65</b>	258
<b>MX 45</b>	169	<b>MXG 65</b>	322
<b>MXG 45</b>	209		
<b>MXL 45</b>	249		

Remarks 1 : The table shows representative model numbers only and is also applicable to same size of MX.  
2 : Table shows the total length for the slide unit with scrapers at both ends.

## ● Mounting slide unit

In the slide unit, mounting holes are also prepared on the middle of slide unit (see Fig.1) to support any direction of load and moment in good balance.

It is recommended to fix all mounting holes to have full performance of products.

For mounting slide unit of Compact block type, insertion depth shown in Table 11 is recommended to keep certain fixing strength.

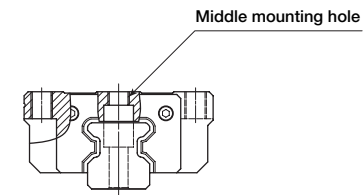

Fig.1 Middle mounting hole of slide unit

Table 11.1 Insertion screw depth of slide unit mounting holes for compact block type

unit : mm

Model number	Recommended minimum depths
<b>MXS 15</b>	4.5
<b>MXS 20</b>	5.5
<b>MXS 25</b>	7
<b>MXS 30</b>	9

Remarks : The table shows representative model numbers only and is also applicable to same size of MX.

Table 11.2 Insertion screw depth of slide unit mounting holes for low section block type

unit : mm

Model number	Recommended minimum depths
<b>MXNS 35</b>	8.5
<b>MXNS 45</b>	10.5
<b>MXNS 55</b>	14

Remarks : The table shows representative model numbers only and is also applicable to same size of MX.

## Track rail length

Standard and maximum lengths of track rails are shown in Table 12.1 and 12.2.

Track rail in any length is also available. Simply indicate the necessary length of track rail in millimeter (mm) in the identification number.

In non-interchangeable specification, for track rail longer than the maximum length shown in Table 12.1 and 12.2, butt-jointing track rails are available upon request. In this case, indicate supplemental code "/A" in the identification number.

E dimensions at both ends are the same unless otherwise specified. To change these dimensions, specify the specified rail mounting hole positions (supplemental code "/E") of special specification.

Table 12.1 Standard and maximum lengths of track rails

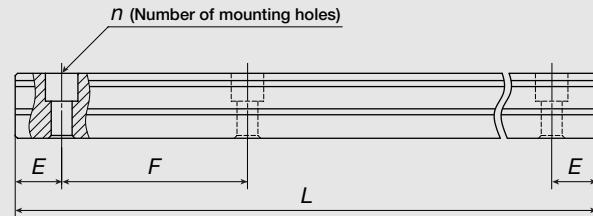

unit : mm

Item	Model number	MX 15	MX 20	MX 25	MX 30	MX 35
Standard length $L (n)$		180( 3)	240( 4)	240( 4)	480( 6)	480( 6)
		240( 4)	480( 8)	480( 8)	640( 8)	640( 8)
		360( 6)	660(11)	660(11)	800(10)	800(10)
		480( 8)	840(14)	840(14)	1 040(13)	1 040(13)
		660(11)	1 020(17)	1 020(17)	1 200(15)	1 200(15)
Mounting hole pitch $F$		60	60	60	80	80
$E$		30	30	30	40	40
Reference dimension $E^{(1)}$	Over (Incl.)	7	8	9	10	10
	Under	37	38	39	50	50
Maximum length $^{(2)}$		1 500 (1 980)	1 980 (3 000)	3 000 (3 960)	2 960 (4 000)	2 960 (4 000)
Item	Model number	MX 45	MX 55	MX 65		
Standard length $L (n)$		840( 8)	840( 7)	1 500(10)		
		1 050(10)	1 200(10)	1 950(13)		
		1 260(12)	1 560(13)	3 000(20)		
		1 470(14)	1 920(16)			
		1 995(19)	3 000(25)			
Mounting hole pitch $F$		105	120	150		
$E$		52.5	60	75		
Reference dimension $E^{(1)}$	Over (Incl.)	12.5	15	17		
	Under	65	75	92		
Maximum length $^{(2)}$		2 940 (3 990)	3 000 (3 960)	3 000 (3 900)		

Note<sup>(1)</sup> : Not applicable to the track rail with female threads for bellows (Supplemental code /J).

<sup>(2)</sup> : The track rails can be manufactured up to the maximum length shown in parentheses. If required, please consult IICO for further information.

Remarks 1 : The table shows representative model numbers and is also applicable to all models in the same size.

2 : In half pitch specification ("HP"), refer Table 12.2.

Table 12.2 Standard and maximum lengths of track rails (Half pitch specification /HP)

unit : mm

Item	Model number	MX 15.../HP	MX 20.../HP	MX 25.../HP	MX 30.../HP	MX 35.../HP
Standard length $L (n)$		180( 6)	240( 8)	480(16)	480(12)	480(12)
		240( 8)	480(16)	660(22)	640(16)	640(16)
		360(12)	660(22)	840(28)	800(20)	800(20)
		480(16)	840(28)	1 020(34)	1 040(26)	1 040(26)
		660(22)	1 020(34)	1 200(40)	1 200(30)	1 200(30)
Mounting hole pitch $F$		30	30	30	40	40
$E$		15	15	15	20	20
Reference dimension $E^{(1)}$	Over (Incl.)	7	8	9	10	10
	Under	22	23	24	30	30
Maximum length $^{(2)}$		1 500 (1 980)	1 980 (3 000)	3 000 (3 960)	2 960 (4 000)	2 960 (4 000)
Item	Model number	MX 45.../HP	MX 55.../HP	MX 65.../HP		
Standard length $L (n)$		840(16)	840(14)	1 500(20)		
		1 050(20)	1 200(20)	1 950(26)		
		1 260(24)	1 560(26)	3 000(40)		
		1 470(28)	1 920(32)			
Mounting hole pitch $F$		52.5	60	75		
$E$		26.25	30	37.5		
Reference dimension $E^{(1)}$	Over (Incl.)	12.5	15	17		
	Under	38.75	45	54.5		
Maximum length $^{(2)}$		2 940 (3 990)	3 000 (3 960)	3 000 (3 975)		

Note <sup>(1)</sup> : Not applied to optional specification "female threads for bellows" (supplemental code "/J", "/JJ")

<sup>(2)</sup> : The track rails can be manufactured up to the maximum length shown in parentheses. If required, please consult IICO.

Remark : The above table shows representative model number but is applicable to all models of the same size.

# IKO C-Lube Linear Roller Way Super MX

## Flange type mounting from top/bottom MXC, MX, MXG, MXL

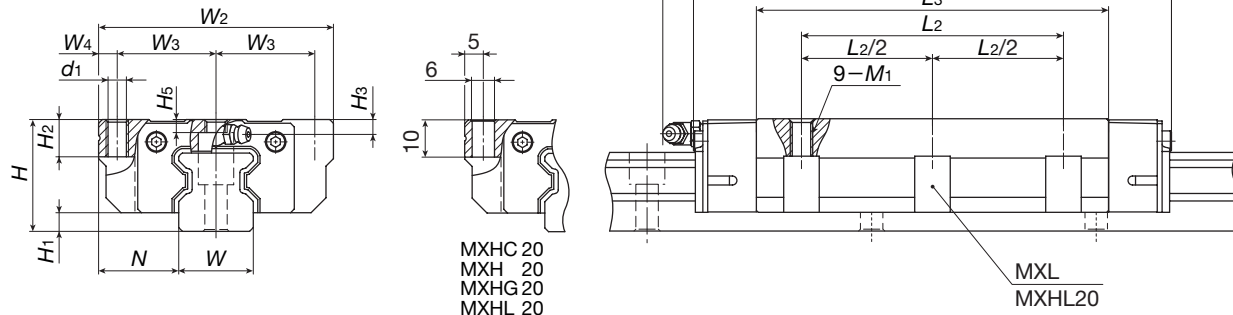

Models mounted from bottom only <sup>(1)</sup>

Model number	Interchangeable	Mass (Ref.)		Dimension of assembly mm			Dimensions of slide unit mm									
		Slide unit kg	Track rail <sup>(2)</sup> kg/m	H	H <sub>1</sub>	N	W <sub>2</sub>	W <sub>3</sub>	W <sub>4</sub>	L <sub>1</sub>	L <sub>2</sub>	L <sub>3</sub>	L <sub>4</sub>	d <sub>1</sub>	M <sub>1</sub>	H <sub>2</sub>
<b>MXC 15</b>	☆	0.13	1.65	24	4	16	47	19	4.5	52	—	24	55	4.4	M 5	7
<b>MX 15</b>	☆	0.20								68	30	40	71			
<b>MXG 15</b>	☆	0.28								84	56	87				
<b>MXC 20 <sup>(1)</sup></b>	☆	0.29	2.73	30	5	21.5	63	26.5	5	66	—	31.6	74	— <sup>(1)</sup>	M 6 <sup>(1)</sup>	10
<b>MX 20 <sup>(1)</sup></b>	☆	0.44								86	40	51.6	94			
<b>MXG 20 <sup>(1)</sup></b>	☆	0.61								106	71.6	114				
<b>MXL 20 <sup>(1)</sup></b>	☆	0.80								128	70	94.1	136			
<b>MXC 25</b>	☆	0.44								74	—	36	83			
<b>MX 25</b>	☆	0.67	3.59	36	6	23.5	70	28.5	6.5	98	45	60	107	7	M 8	10
<b>MXG 25</b>	☆	0.84								113	75	122				
<b>MXL 25</b>	☆	1.08								137	70	99	146			
<b>MXC 30</b>	☆	0.78	5.01	42	6.5	31	90	36	9	85	—	42.4	95	8.5	M10	10
<b>MX 30</b>	☆	1.20								113	52	70.4	123			
<b>MXG 30</b>	☆	1.58								134	91.4	144				
<b>MXL 30</b>	☆	2.03								162	80	119.4	172			

Note<sup>(1)</sup>: MXC20, MX20, MXG20 and MXL20 can be mounted from top only.

For mounting from bottom, MXHC20, MXH20, MXHG20 and MXHL20 which has same dimensions as above model, can be used.

<sup>(2)</sup>: Track rail length L are shown in Table 12.1.

<sup>(3)</sup>: Track rail mounting bolts are not appended. Hexagon socket bolts of JIS B 1176 strength division 12.9 or equivalent are recommended.

<sup>(4)</sup>: The directions of basic dynamic load rating (C), basic static load rating (C<sub>0</sub>) and static moment rating (T<sub>0</sub>, T<sub>x</sub> and T<sub>y</sub>) are shown in the sketches below. The upper values in the T<sub>x</sub> and T<sub>y</sub> column apply to one slide unit, and the lower values apply to two units in close contact.

Remark 1: The mark ☆ indicates that interchangeable specification products are available.

2: For grease nipple specification, see Table 10.1 and 10.2 on page 102 and 103.

3: A grease nipple mounting thread is provided on the left and right end plates respectively.

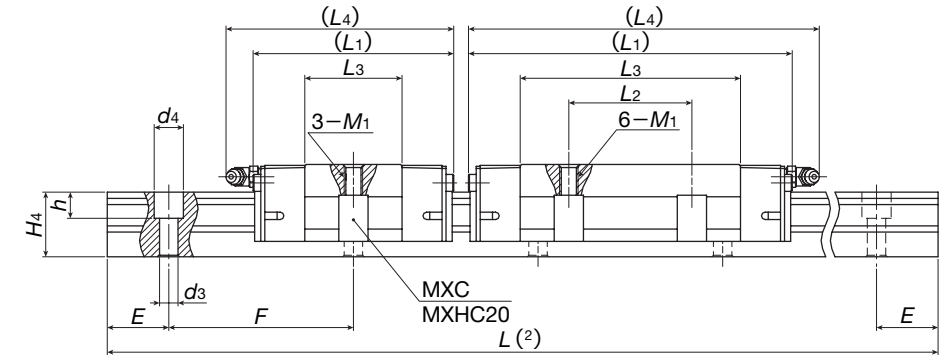
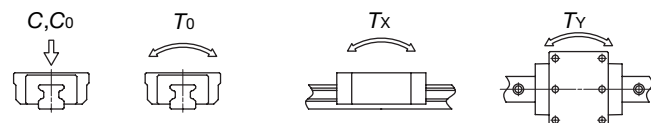

H <sub>3</sub>	H <sub>5</sub>	Dimension of track rail mm								Recommended Mounting bolt for track rail <sup>(3)</sup> mm Bolt size × length	Basic dynamic load rating <sup>(4)</sup> C N	Basic static load rating <sup>(4)</sup> C <sub>0</sub> N	Static moment rating <sup>(4)</sup>		
		W	H <sub>4</sub>	d <sub>3</sub>	d <sub>4</sub>	h	E	F	T <sub>0</sub> N·m				T <sub>x</sub> N·m	T <sub>y</sub> N·m	
3.5	3	15	16.5	4.5	8	6	30	60	M4×16	7 730	12 000	113	50.6 457	50.6 457	
										11 500	20 000	188	136 942	136 942	
										14 900	28 000	263	262 1 590	262 1 590	
4	3.5	20	21	6	9.5	8.5	30	60	M5×20	16 100	26 400	341	150 1 260	150 1 260	
										23 400	42 700	550	379 2 520	379 2 520	
										30 100	58 900	760	713 4 200	713 4 200	
										37 200	77 200	996	1 210 6 560	1 210 6 560	
										21 600	33 800	500	213 1 810	213 1 810	
5	5	23	24.5	7	11	9	30	60	M6×25	32 100	56 300	833	573 3 800	573 3 800	
										38 200	70 300	1 040	885 5 380	885 5 380	
										47 400	92 800	1 370	1 530 8 480	1 530 8 480	
										29 200	44 600	808	329 2 740	329 2 740	
6.5	5.5	28	28	9	14	12	40	80	M8×28	43 400	74 400	1 350	883 5 780	883 5 780	
										53 200	96 700	1 750	1 470 8 740	1 470 8 740	
										65 600	126 000	2 290	2 500 13 600	2 500 13 600	

### Example of identification number of assembled set (For details, see "Identification number and specification".)

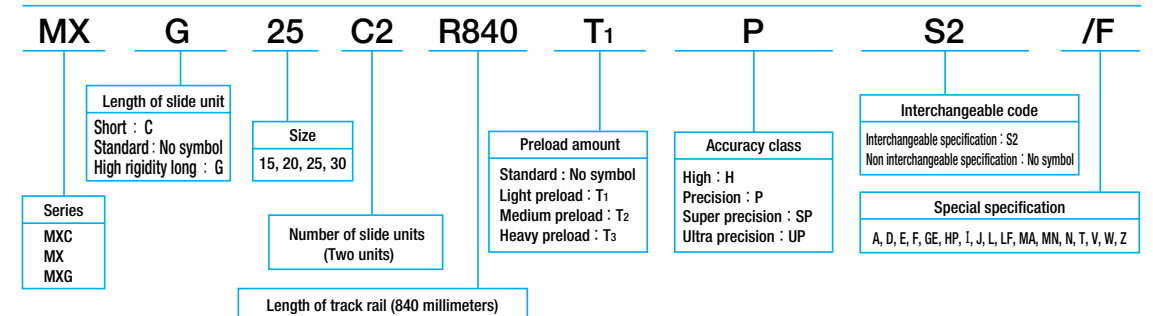

Flange type mounting from top/bottom  
**MXC, MX, MXG, MXL**

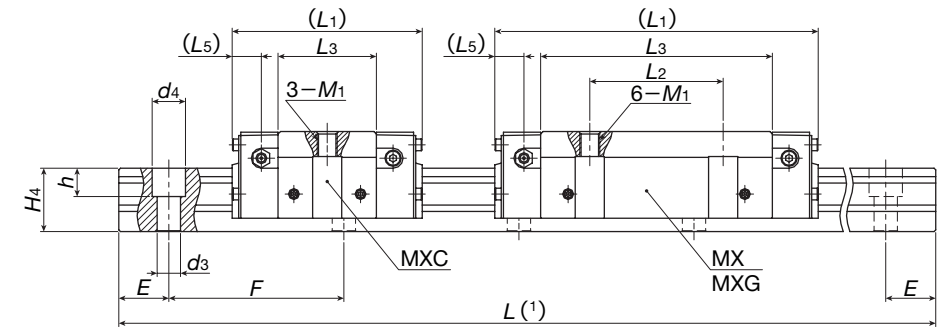
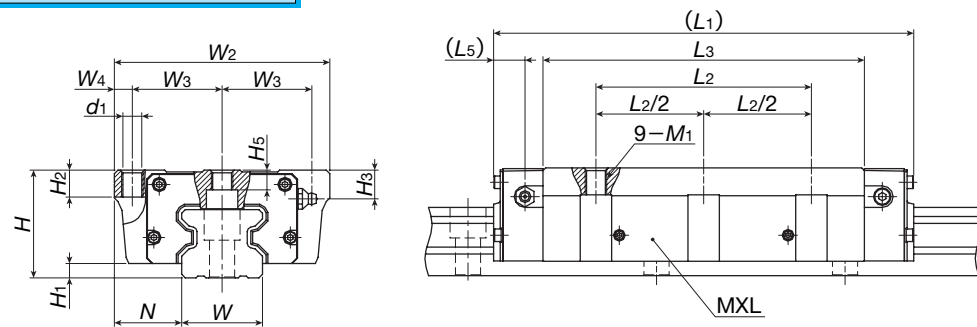

Model number	Interchangeable	Mass (Ref.)		Dimension of assembly mm			Dimensions of slide unit mm									
		Slide unit kg	Track rail <sup>(2)</sup> kg/m	H	H <sub>1</sub>	N	W <sub>2</sub>	W <sub>3</sub>	W <sub>4</sub>	L <sub>1</sub>	L <sub>2</sub>	L <sub>3</sub>	L <sub>5</sub>	d <sub>1</sub>	M <sub>1</sub>	H <sub>2</sub>
<b>MXC 35</b>	☆	1.13	6.88	48	6.5	33	100	41	9	92	—	46.6	12.7	8.5	M10	13
<b>MX 35</b>	☆	1.76								124	—	78.6				
<b>MXG 35</b>	☆	2.41								152	—	106.6				
<b>MXL 35</b>	☆	3.00								184	100	138.6				
<b>MXC 45</b>	☆	2.11	10.8	60	8	37.5	120	50	10	114	—	59	17.5	10.5	M12	15
<b>MX 45</b>	☆	3.26								154	—	99				
<b>MXG 45</b>	☆	4.60								194	80	139				
<b>MXL 45</b>	☆	5.66								234	120	179				
<b>MXC 55</b>	☆	3.49	14.1	70	9	43.5	140	58	12	136	—	72	20	12.5	M14	17
<b>MX 55</b>	☆	5.42								184	—	120				
<b>MXG 55</b>	☆	7.93								238	95	174				
<b>MXL 55</b>	☆	9.33								282	140	216				
<b>MXC 65</b>	☆	7.18	22.6	90	12	53.5	170	71	14	180	—	95	26.3	14.5	M16	23
<b>MX 65</b>	☆	11.5								244	—	159				
<b>MXG 65</b>	☆	16.0								308	110	223				
<b>MXL 65</b>	☆	21.0								362	170	265				

Note<sup>(1)</sup>: Track rail length L are shown in Table 12.1.  
<sup>(2)</sup>: Track rail mounting bolts are not appended. Hexagon socket bolts of JIS B 1176 strength division 12.9 or equivalent are recommended.  
<sup>(3)</sup>: The directions of basic dynamic load rating (C), basic static load rating (C<sub>0</sub>) and static moment rating (T<sub>0</sub>, T<sub>x</sub> and T<sub>y</sub>) are shown in the sketches below. The upper values in the T<sub>x</sub> and T<sub>y</sub> column apply to one slide unit, and the lower values apply to two units in close contact.  
 Remark 1: The mark ☆ indicates that interchangeable specification products are available.  
 2: For grease nipple specification, see Table 10.1 and 10.2 on page 102 and 103.  
 3: A grease nipple mounting thread is provided on the left and right end plates respectively.

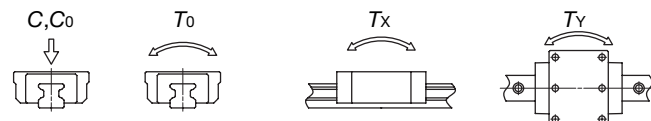

H <sub>3</sub>	H <sub>5</sub>	Dimension of track rail mm								Recommended Mounting bolt for track rail <sup>(2)</sup> mm Bolt size × length	Basic dynamic load rating <sup>(3)</sup> C N	Basic static load rating <sup>(3)</sup> C <sub>0</sub> N	Static moment rating <sup>(3)</sup>		
		W	H <sub>4</sub>	d <sub>3</sub>	d <sub>4</sub>	h	E	F	T <sub>0</sub> N·m				T <sub>x</sub> N·m	T <sub>y</sub> N·m	
13	7	34	32	9	14	12	40	80	M 8×35	39 500	60 000	1 300	506	506	
												2 170	1 360	1 360	
												2 930	2 440	2 440	
												3 800	4 060	4 060	
16	11	45	38	14	20	17	52.5	105	M12×40	64 100	95 600	2 660	1 010	1 010	
												4 430	2 700	2 700	
												6 200	16 800	16 800	
												7 980	29 000	29 000	
16	14	53	43	16	23	20	60	120	M14×45	99 700	149 000	4 830	1 880	1 880	
												8 040	5 040	5 040	
												11 700	31 100	31 100	
												15 400	57 000	57 000	
18	18.5	63	56	18	26	22	75	150	M16×60	174 000	249 000	9 790	4 200	4 200	
												16 300	11 300	11 300	
												22 800	69 300	69 300	
												30 300	21 800	21 800	

Example of identification number of assembled set (For details, see "Identification number and specification".)

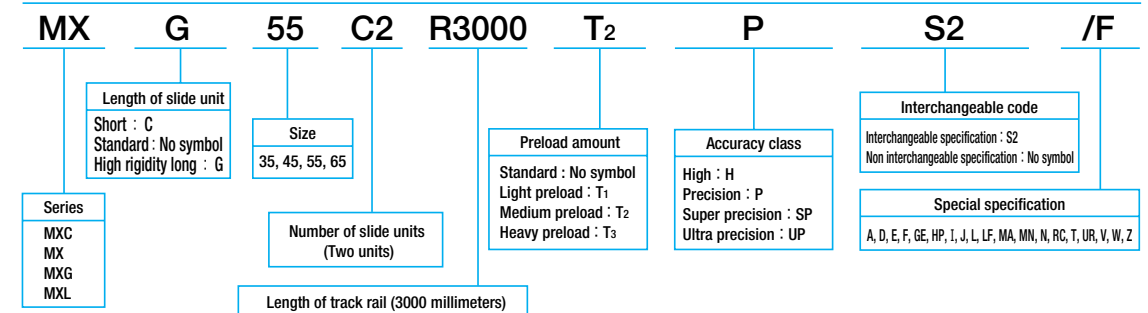



## Block type mounting from top MXD, MXDG

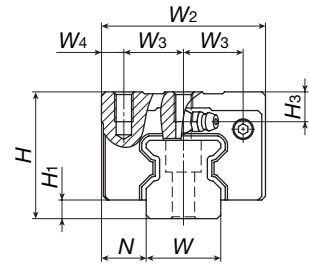

MXD  
MXDG

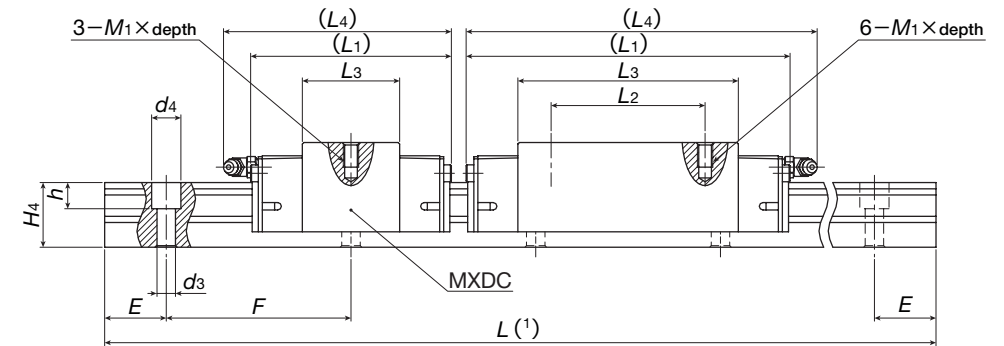
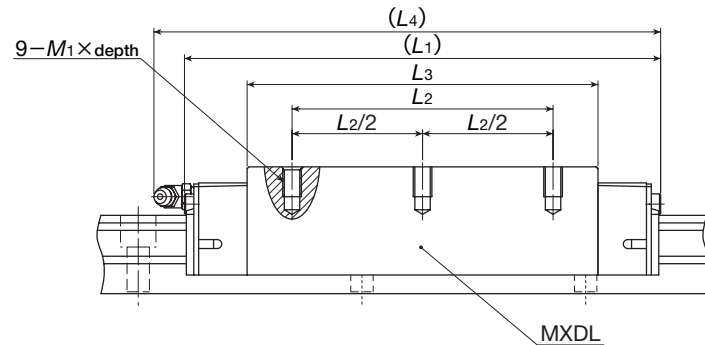

Model number	Interchangeable	Mass (Ref.)		Dimension of assembly mm			Dimensions of slide unit mm									
		Slide unit kg	Track rail <sup>(1)</sup> kg/m	H	H <sub>1</sub>	N	W <sub>2</sub>	W <sub>3</sub>	W <sub>4</sub>	L <sub>1</sub>	L <sub>2</sub>	L <sub>3</sub>	L <sub>4</sub>	M <sub>1</sub> ×depth	H <sub>3</sub>	
MXDC 15	☆	0.13	1.65	28	4	9.5	34	13	4	52	—	24	55	M4×8	7.5	
MXD 15	☆	0.19								68	—	40	71			
MXDG 15	☆	0.26								84	26	56	87			
MXDC 20	☆	0.25	2.73	34	5	12	44	16	6	66	—	31.6	74	M5×8	8	
MXD 20	☆	0.38								86	36	51.6	94			
MXDG 20	☆	0.52								106	50	71.6	114			
MXDL 20	☆	0.67								128	70	94.1	136			
MXDC 25	☆	0.36	3.59	40	6	12.5	48	17.5	6.5	74	—	36	83	M6×12	9	
MXD 25	☆	0.55								98	35	60	107			
MXDG 25	☆	0.68								113	50	75	122			
MXDL 25	☆	0.88								137	70	99	146			
MXDC 30	☆	0.60	5.01	45	6.5	16	60	20	10	85	—	42.4	95	M8×12	9.5	
MXD 30	☆	0.92								113	40	70.4	123			
MXDG 30	☆	1.18								134	60	91.4	144			
MXDL 30	☆	1.52								162	80	119.4	172			

Note<sup>(1)</sup>: Track rail length L are shown in Table 12.1.

<sup>(2)</sup>: Track rail mounting bolts are not appended. Hexagon socket bolts of JIS B 1176 strength division 12.9 or equivalent are recommended.

<sup>(3)</sup>: The directions of basic dynamic load rating (C), basic static load rating (C<sub>0</sub>) and static moment rating (T<sub>0</sub>, T<sub>x</sub> and T<sub>y</sub>) are shown in the sketches below. The upper values in the T<sub>x</sub> and T<sub>y</sub> column apply to one slide unit, and the lower values apply to two units in close contact.

Remark 1: The mark ☆ indicates that interchangeable specification products are available.

2: For grease nipple specification, see Table 10.1 and 10.2 on page 102 and 103.

3: A grease nipple mounting thread is provided on the left and right end plates respectively.

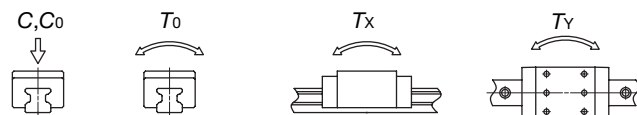

Dimension of track rail mm							Recommended Mounting bolt for track rail <sup>(2)</sup> mm Bolt size × length	Basic dynamic load rating <sup>(3)</sup> C N	Basic static load rating <sup>(3)</sup> C <sub>0</sub> N	Static moment rating <sup>(3)</sup>		
W	H <sub>4</sub>	d <sub>3</sub>	d <sub>4</sub>	h	E	F				T <sub>0</sub> N·m	T <sub>x</sub> N·m	T <sub>y</sub> N·m
15	16.5	4.5	8	6	30	60	M4×16	7 730	12 000	113	50.6	50.6
										188	136	136
										263	942	942
20	21	6	9.5	8.5	30	60	M5×20	16 100	26 400	341	150	150
										550	1 260	1 260
										760	379	379
										996	2 520	2 520
23	24.5	7	11	9	30	60	M6×25	21 600	33 800	500	213	213
										833	573	573
										1 040	3 800	3 800
										1 370	885	885
										1 370	5 380	5 380
28	28	9	14	12	40	80	M8×28	29 200	44 600	808	329	329
										1 350	2 740	2 740
										1 750	883	883
										1 750	5 780	5 780
										2 290	1 470	1 470

Example of identification number of assembled set (For details, see "Identification number and specification".)

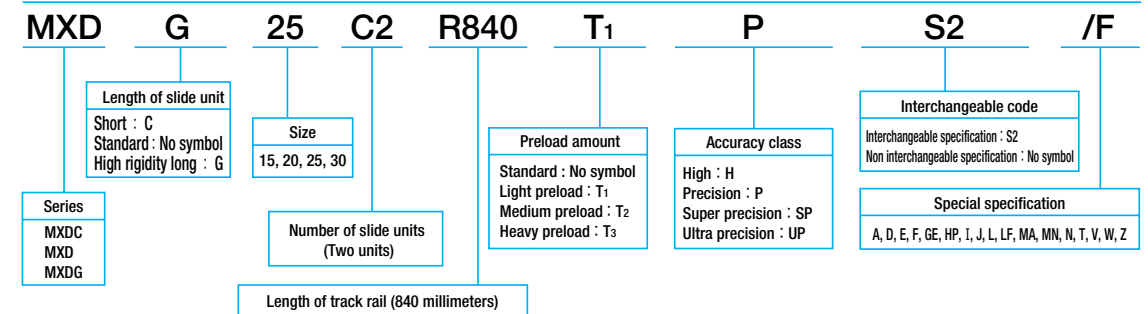

## Compact block type mounting from top MXS, MXSG

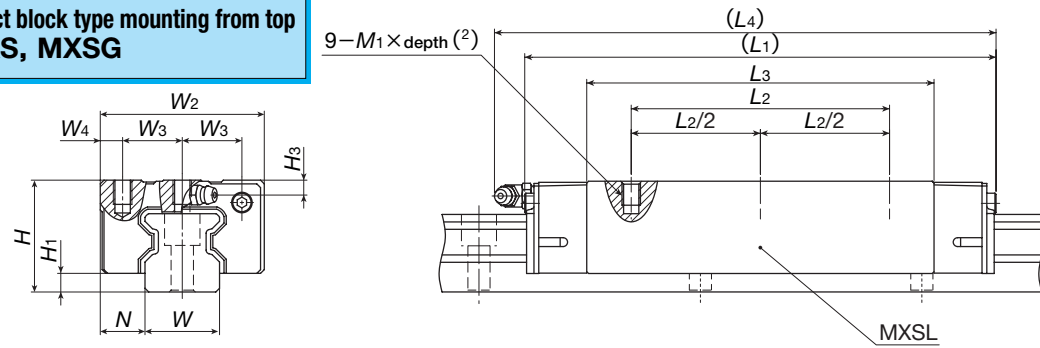

MXS  
MXSG

Model number	Interchangeable	Mass (Ref.)		Dimension of assembly mm			Dimensions of slide unit mm								
		Slide unit kg	Track rail <sup>(1)</sup> kg/m	H	H <sub>1</sub>	N	W <sub>2</sub>	W <sub>3</sub>	W <sub>4</sub>	L <sub>1</sub>	L <sub>2</sub>	L <sub>3</sub>	L <sub>4</sub>	M <sub>1</sub> ×depth <sup>(2)</sup>	H <sub>3</sub>
MXSC 15	☆	0.099	1.65	24	4	9.5	34	13	4	52	—	24	55	M4× 5.5	3.5
MXS 15	☆	0.15								68	—	40	71		
MXSG 15	☆	0.21								84	26	56	87		
MXSC 20	☆	0.21	2.73	30	5	12	44	16	6	66	—	31.6	74	M5× 6.5	4
MXS 20	☆	0.31								86	36	51.6	94		
MXSG 20	☆	0.42								106	50	71.6	114		
MXSL 20		0.55								128	70	94.1	136		
MXSC 25	☆	0.30	3.59	36	6	12.5	48	17.5	6.5	74	—	36	83	M6× 9	5
MXS 25	☆	0.47								98	35	60	107		
MXSG 25	☆	0.57								113	50	75	122		
MXSL 25		0.74								137	70	99	146		
MXSC 30	☆	0.54	5.01	42	6.5	16	60	20	10	85	—	42.4	95	M8× 11	6.5
MXS 30	☆	0.83								113	40	70.4	123		
MXSG 30	☆	1.05								134	60	91.4	144		
MXSL 30		1.37								162	80	119.4	172		

Note<sup>(1)</sup>: Track rail length L are shown in Table 12.1.

<sup>(2)</sup>: Insertion screw depth for MXS15, MXS20 and MXS25 are shown in Table 11.

<sup>(3)</sup>: Track rail mounting bolts are not appended. Hexagon socket bolts of JIS B 1176 strength division 12.9 or equivalent are recommended.

<sup>(4)</sup>: The directions of basic dynamic load rating (C), basic static load rating (C<sub>0</sub>) and static moment rating (T<sub>0</sub>, T<sub>x</sub> and T<sub>y</sub>) are shown in the sketches below. The upper values in the T<sub>x</sub> and T<sub>y</sub> column apply to one slide unit, and the lower values apply to two units in close contact.

Remark 1: The mark ☆ indicates that interchangeable specification products are available.

2: For grease nipple specification, see Table 10.1 and 10.2 on page 102 and 103.

3: A grease nipple mounting thread is provided on the left and right end plates respectively.

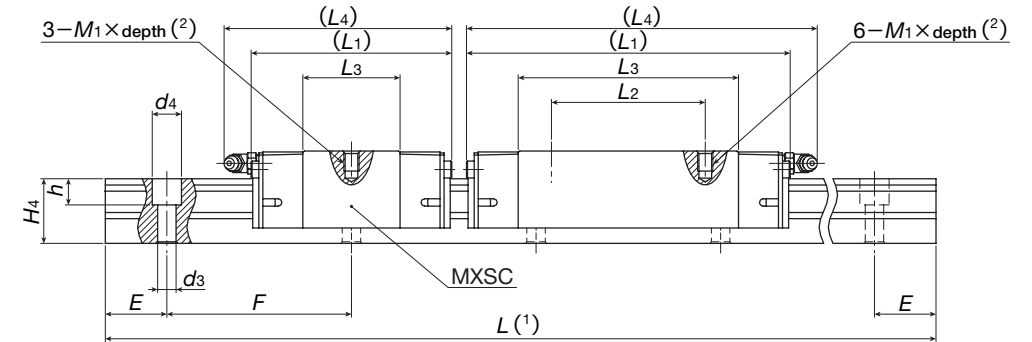
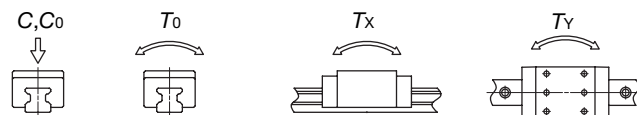

Dimension of track rail mm							Recommended Mounting bolt for track rail <sup>(3)</sup> mm Bolt size × length	Basic dynamic load rating <sup>(4)</sup> C N	Basic static load rating <sup>(4)</sup> C <sub>0</sub> N	Static moment rating <sup>(4)</sup>		
W	H <sub>4</sub>	d <sub>3</sub>	d <sub>4</sub>	h	E	F				T <sub>0</sub> N·m	T <sub>x</sub> N·m	T <sub>y</sub> N·m
15	16.5	4.5	8	6	30	60	M4× 16	7 730	12 000	113	50.6	50.6
								11 500	20 000	188	457	457
								14 900	28 000	263	1 590	1 590
20	21	6	9.5	8.5	30	60	M5× 20	16 100	26 400	341	150	150
								23 400	42 700	550	1 260	1 260
								30 100	58 900	760	379	379
23	24.5	7	11	9	30	60	M6× 25	37 200	77 200	996	2 520	2 520
								21 600	33 800	500	713	713
								32 100	56 300	833	4 200	4 200
28	28	9	14	12	40	80	M8× 28	47 400	92 800	1 370	1 210	1 210
								29 200	44 600	808	6 560	6 560
								43 400	74 400	1 350	213	213
								53 200	96 700	1 750	885	885
								65 600	126 000	2 290	5 380	5 380
											1 530	1 530
											8 480	8 480
											2 740	2 740
											883	883
											5 780	5 780
											1 470	1 470
											8 740	8 740
											2 500	2 500
											13 600	13 600

Example of identification number of assembled set (For details, see "Identification number and specification".)

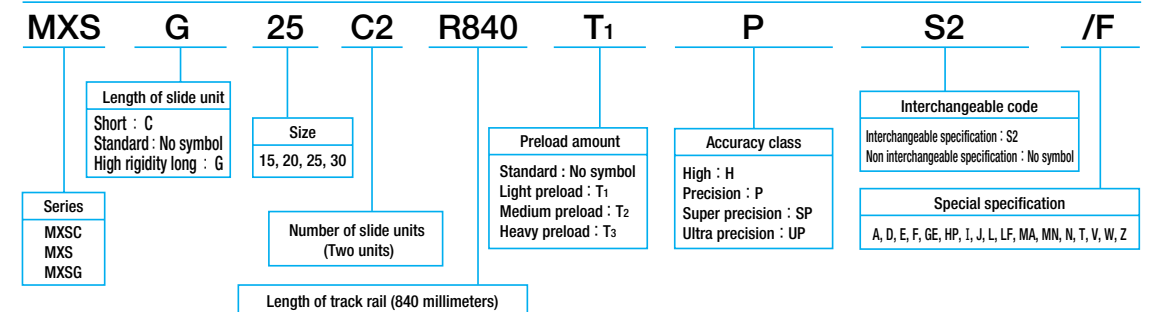

**Flange type mounting from top  
MXN, MXNG**

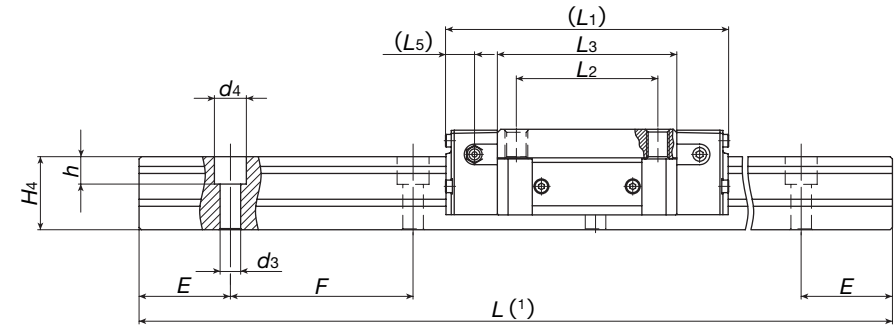
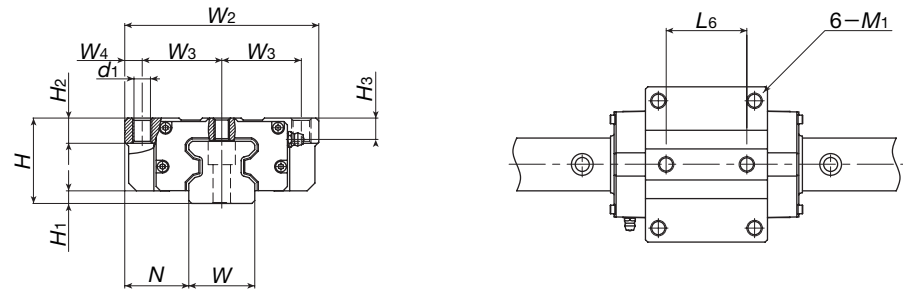

Model number	Interchangeable	Mass (Ref.)		Dimension of assembly mm			Dimensions of slide unit mm									
		Slide unit kg	Track rail <sup>(1)</sup> kg/m	H	H <sub>1</sub>	N	W <sub>2</sub>	W <sub>3</sub>	W <sub>4</sub>	L <sub>1</sub>	L <sub>2</sub>	L <sub>3</sub>	L <sub>5</sub>	L <sub>6</sub>	d <sub>1</sub> <sup>(2)</sup>	M <sub>1</sub>
<b>MXN 35</b>	☆	1.55	6.88	44	6.5	33	100	41	9	124	62	78.6	12.7	52	8.5	M10
<b>MXNG 35</b>	☆	2.13								152		106.6				
<b>MXN 45</b>	☆	2.58	10.8	52	8	37.5	120	50	10	154	80	99	17.5	60	10.5	M12
<b>MXNG 45</b>	☆	3.73								194		139				
<b>MXN 55</b>	☆	4.61	14.1	63	9	43.5	140	58	12	184	95	120	20	70	12.5	M14
<b>MXNG 55</b>	☆	6.94								238		174				

Note<sup>(1)</sup> : Track rail length L are shown in Table 12.1 and 12.2 on page A-86 and A-87.  
<sup>(2)</sup> : Not applicable to middle mounting holes of slide unit. Their mounting direction is only downward.  
<sup>(3)</sup> : It is recommended to secure actual screwing depth should not exceed the maximum screwing depth in the table.  
<sup>(4)</sup> : Track rail mounting bolts are not appended. Hexagon socket bolts of JIS B 1176 strength division 12.9 or equivalent are recommended.  
<sup>(5)</sup> : The directions of basic dynamic load rating (C), basic static load rating (C<sub>0</sub>) and static moment rating (T<sub>0</sub>, T<sub>x</sub> and T<sub>y</sub>) are shown in the sketches below. The upper values in the T<sub>x</sub> and T<sub>y</sub> column apply to one slide unit, and the lower values apply to two units in close contact.  
**Remark 1** : The mark ☆ indicates that interchangeable specification products are available.  
**2** : For grease nipple specification, see Table 10.1 and 10.2 on page 102 and 103.  
**3** : In size 35 female threads for grease nipple are prepared on both side faces and front face of end plate. Thread size of front face is smaller than other threads thus, please consult **IKO** if grease nipple for front face is required.

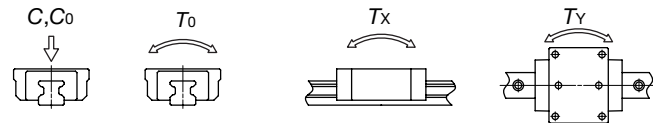

Maximum screwing depth <sup>(3)</sup>	Dimension of track rail mm										Recommended Mounting bolt for track rail <sup>(4)</sup> mm Bolt size × length	Basic dynamic load rating <sup>(5)</sup> C N	Basic static load rating <sup>(5)</sup> C <sub>0</sub> N	Static moment rating <sup>(5)</sup>		
	H <sub>2</sub>	H <sub>3</sub>	W	H <sub>4</sub>	d <sub>3</sub>	d <sub>4</sub>	h	E	F	T <sub>0</sub> N·m				T <sub>x</sub> N·m	T <sub>y</sub> N·m	
11	13	11	34	32	9	14	12	40	80	M 8×35	58 700	100 000	2 170	1 360 8 470	1 360 8 470	
13	15	13.5	45	38	14	20	17	52.5	105	M12×40	95 400	159 000	4 430	2 700 16 800	2 700 16 800	
											124 000	223 000	6 200	5 220 29 000	5 220 29 000	
19	17	16	53	43	16	23	20	60	120	M14×45	148 000	248 000	8 040	5 040 31 100	5 040 31 100	
											198 000	359 000	11 700	10 400 57 000	10 400 57 000	

**Example of identification number of assembled set** (For details, see "Identification number and specification".)

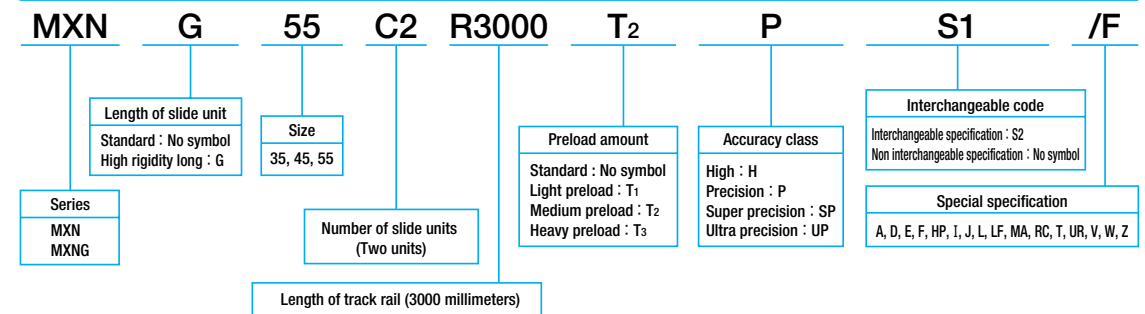

Flange type mounting from top  
MXNS, MXNSG

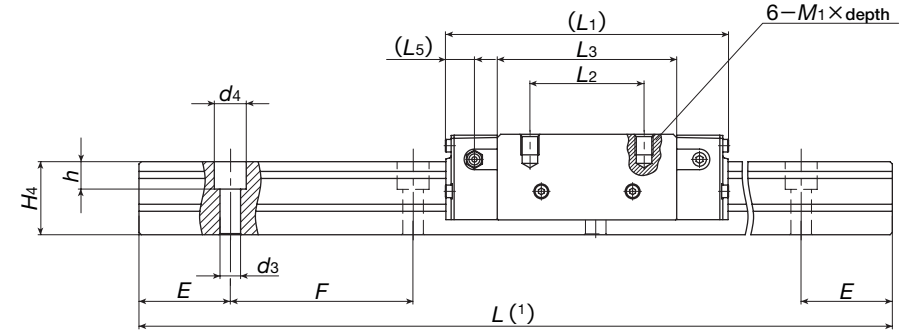
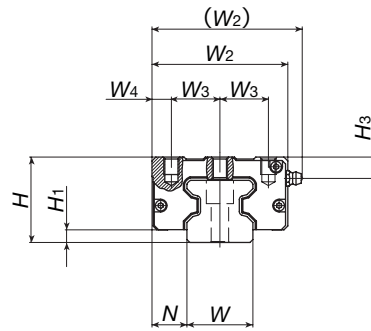

Model number	Interchangeable	Mass (Ref.)		Dimension of assembly mm			Dimensions of slide unit mm								
		Slide unit kg	Track rail <sup>(1)</sup> kg/m	H	H <sub>1</sub>	N	W <sub>1</sub>	W <sub>2</sub>	W <sub>3</sub>	W <sub>4</sub>	L <sub>1</sub>	L <sub>2</sub>	L <sub>3</sub>	L <sub>5</sub>	M <sub>1</sub> ×depth <sup>(2)</sup>
MXNS 35	☆	1.08	6.88	44	6.5	18	80	70	25	10	124	50	78.6	12.7	M 8×9
MXNSG 35	☆	1.42									152	72	106.6		
MXNS 45	☆	1.84	10.8	52	8	20.5	96	86	30	13	154	60	99	17.5	M10×11
MXNSG 45	☆	2.58									194	80	139		
MXNS 55	☆	3.31	14.1	63	9	23.5	112	100	37.5	12.5	184	75	120	20	M12×15
MXNSG 55	☆	4.83									238	95	174		

Note<sup>(1)</sup> : Track rail length L are shown in Table 12.1 and 12.2 on page A-86 and A-87.

<sup>(2)</sup> : It is recommended to secure actual screw depth should not be exceed the maximum screwing depth in table 18.2 on page 32.

Especially the screwing depth of middle mounting threads in width direction should not be exceed maximum screwing depth in the table.

<sup>(3)</sup> : Track rail mounting bolts are not appended. Hexagon socket bolts of JIS B 1176 strength division 12.9 or equivalent are recommended.

<sup>(4)</sup> : The directions of basic dynamic load rating (C), basic static load rating (C<sub>0</sub>) and static moment rating (T<sub>0</sub>, T<sub>x</sub> and T<sub>y</sub>) are shown in the sketches below. The upper values in the T<sub>x</sub> and T<sub>y</sub> column apply to one slide unit, and the lower values apply to two units in close contact.

Remark 1 : The mark ☆ indicates that interchangeable specification products are available.

2 : For grease nipple specification, see Table 10.1 and 10.2 on page 102 and 103.

3 : In size 35 female threads for grease nipple are prepared on both side faces and front face of end plate. Thread size of front face is smaller than other threads thus, please consult IKO if grease nipple for front face is required.

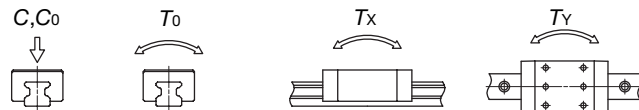

Maximum screwing depth <sup>(2)</sup>	H <sub>3</sub>	Dimension of track rail mm								Recommended Mounting bolt for track rail <sup>(3)</sup> mm Bolt size × length	Basic dynamic load rating <sup>(4)</sup> C N	Basic static load rating <sup>(4)</sup> C <sub>0</sub> N	Static moment rating <sup>(4)</sup>		
		W	H <sub>4</sub>	d <sub>3</sub>	d <sub>4</sub>	h	E	F	T <sub>0</sub> N·m				T <sub>x</sub> N·m	T <sub>y</sub> N·m	
11	11	34	32	9	14	12	40	80	M 8×35	58 700	100 000	2 170	1 360 8 470	1 360 8 470	
13	13.5	45	38	14	20	17	52.5	105	M12×40	95 400	159 000	4 430	2 700 16 800	2 700 16 800	
										124 000	223 000	6 200	5 220 29 000	5 220 29 000	
19	16	53	43	16	23	20	60	120	M14×45	148 000	248 000	8 040	5 040 31 100	5 040 31 100	
										198 000	359 000	11 700	10 400 57 000	10 400 57 000	

Example of identification number of assembled set (For details, see "Identification number and specification".)

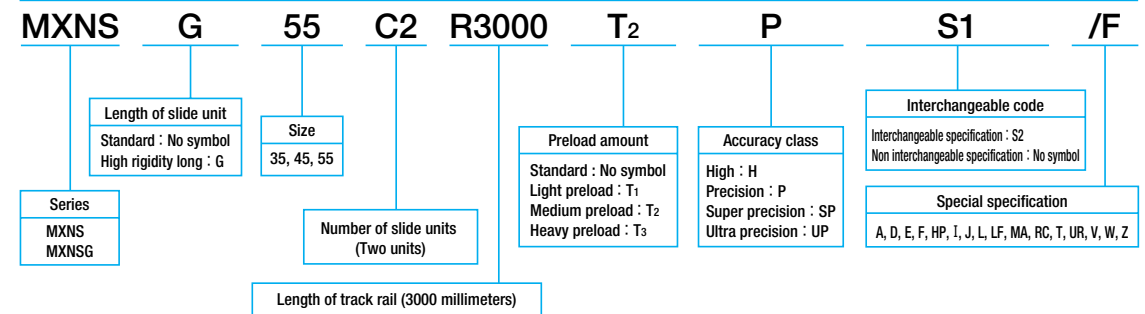

# C-Lube Linear Ball Spline MAG

## MAG/MAGF

Maintenance free type has been released for **IKO** C-Lube Linear Ball Spline MAG having an overwhelmingly high market share in the field of semiconductor and liquid crystal manufacturing systems that are forced to be operated in severe operating conditions of high acceleration/deceleration motion.

### Maintenance free

The **IKO** original lubricating component, C-Lube, is incorporated in the external cylinder and the end plate. Its effectiveness had been proven by endurance tests. This can reduce the cost of the whole system as a result of reduction in the lubrication mechanism in the system and also reduce the running cost as a result of reduction in the man-hours for lubricational maintenance. In addition, grease is prepacked in the external cylinder as standard, so that maintenance free operation for even longer time is achieved.

### Ecology

Regarding the prepacked lubricant in the C-Lube, only the amount of lubricant required to maintain the lubrication performance of the rolling guide is supplied, so that a small amount of lubricant is consumed even for a long-time running while keeping the lubrication performance.

### High rigidity and compactness

Large-diameter steel balls are arranged in two rows and are in four-point contact with the raceways. With this structure, this is a high-rigidity and compact-sized Ball Spline. C-Lube Linear Ball Spline MAG adopts a unique steel ball retaining method requiring no ball retainer, and has a small external diameter of external cylinder for the shaft diameter.

### Interchangeable specification

The external cylinder and the spline shaft can be ordered separately and a single unit can be delivered. The product type, accuracy, and preload type can be combined freely. This is a high-level interchangeable system product. This is the product customer can order for the least quantity when needed, and its delivery time is short.

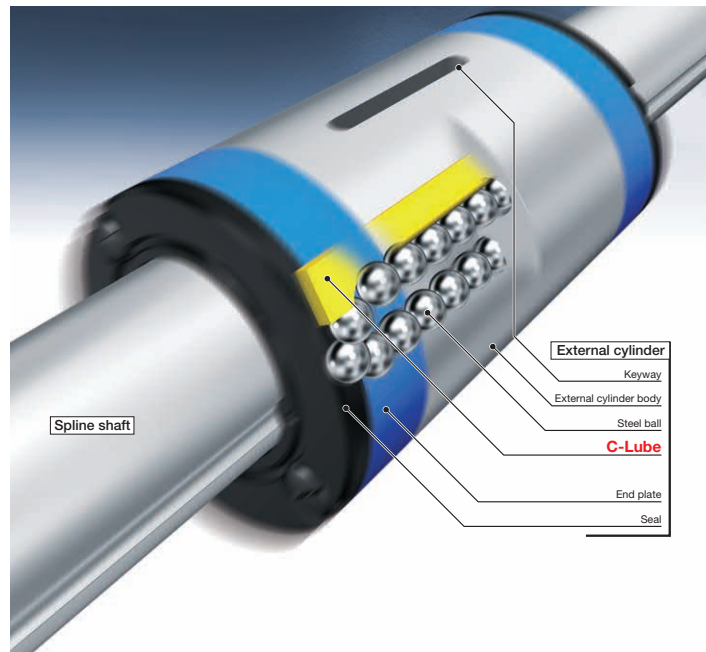

Structure of C-Lube Linear Ball Spline MAG

- U.S. PATENT No.4,799,803
- No.4,505,522
- No.5,490,729
- No.4,505,522
- No.4,390,215
- No.6,190,046
- No.6,176,617
- No.6,082,899
- No.5,967,667
- No.5,464,288
- No.5,356,223

## C-Lube Linear Ball Spline MAG series

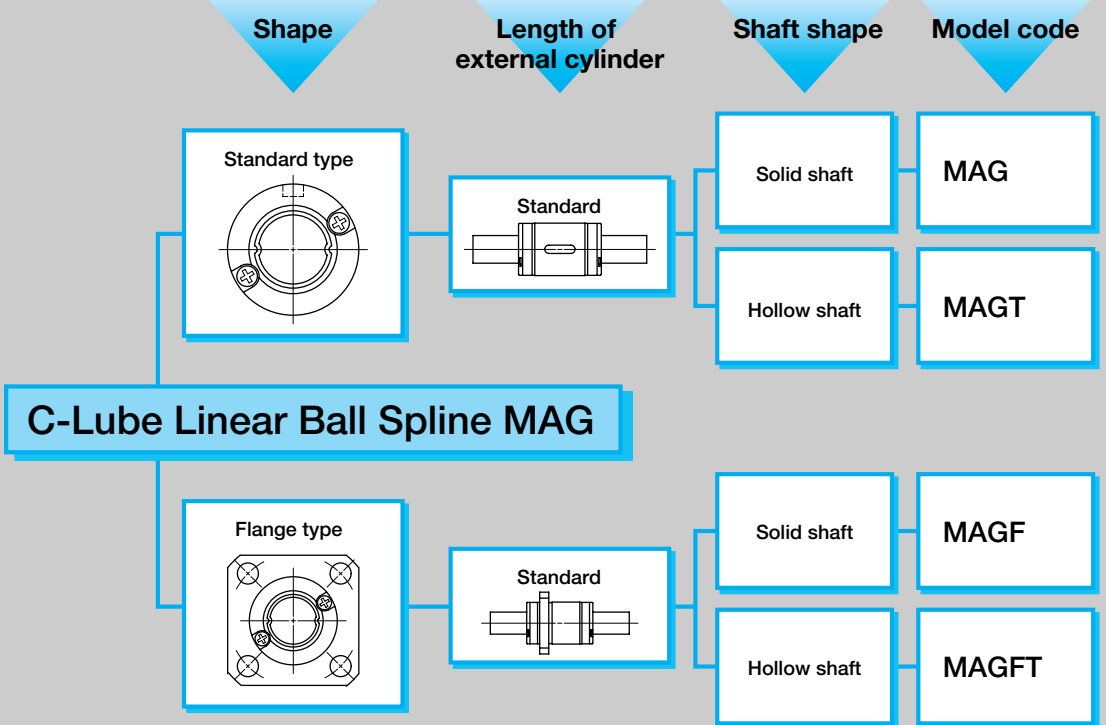

### C-Lube Linear Ball Spline MAG

## Identification Number

The specification of C-Lube Linear Ball Spline MAG is indicated by the identification number, consisting of a model code, a size, a part code, a preload symbol, a classification symbol, an interchangeable code, and any supplemental codes.

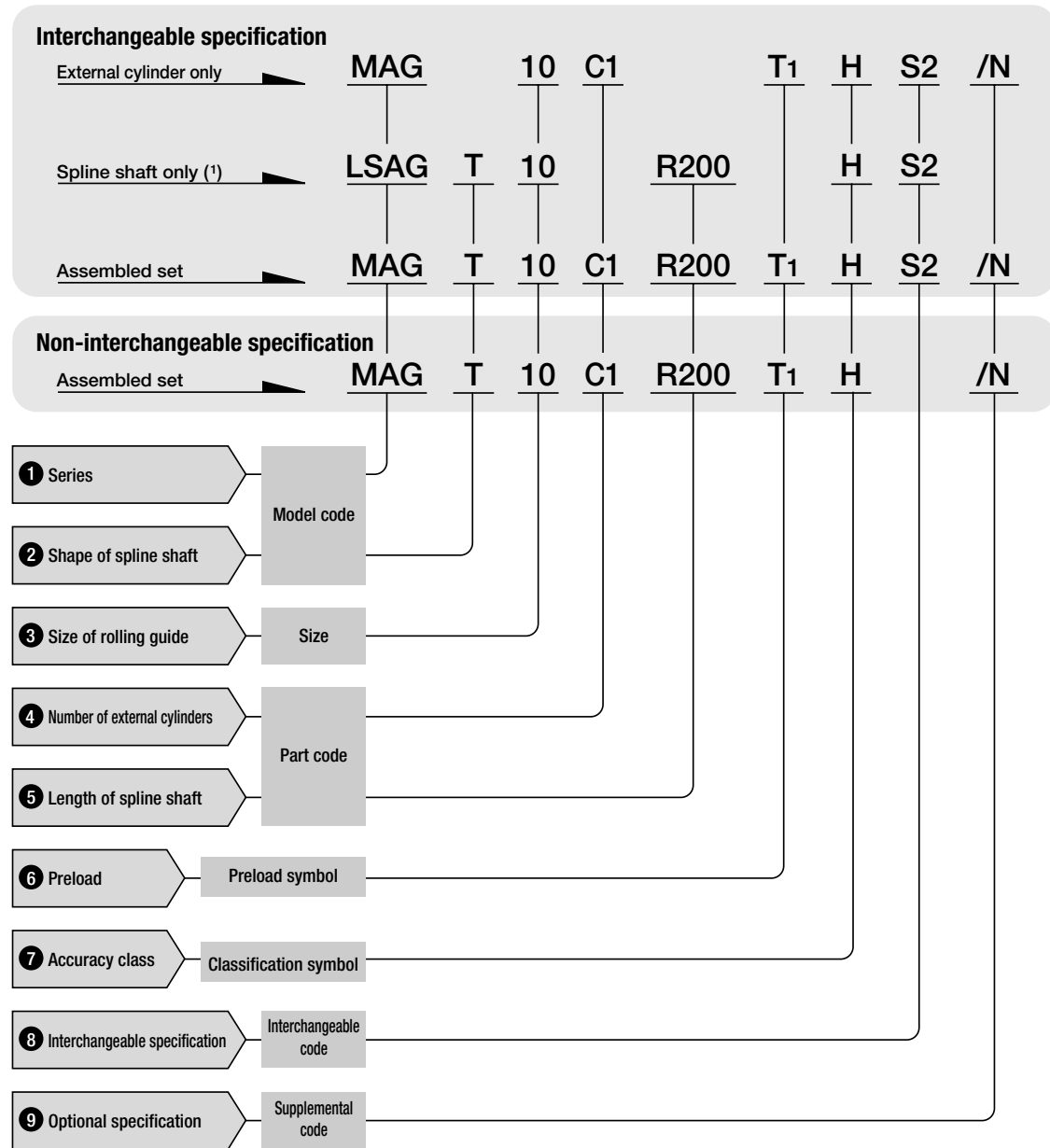

Note(1): In case ordering spline shaft only, model code should be changed as LSAG (Solid shaft) or LSAGT (Hollow shaft).

**1 Series**

Standard type : MAG  
Flange type : MAGF

For applicable models and sizes, see Table 1.  
For the model code of a spline shaft of C-Lube Linear Way MAG, indicate LSAG(T) regardless the external cylinder model to be combined.

---

**2 Shape of spline shaft**

Solid shaft : No symbol  
Hollow shaft : T

---

**3 Size of rolling guide**

5, 6, 8, 10, 12

For applicable models and sizes, see Table 1.

Table 1 Models and sizes of C-Lube Linear Ball Spline MAG

Size	Model	Standard model	Flanged model
		MAG	MAGF
5		☆	☆
6		☆	☆
8		☆	☆
10		☆	☆
12		☆	☆

Remark : ☆ marks are also applicable to interchangeable specification.

**4 Number of external cylinder**

Assembled set : C○  
External cylinder only : C1

For an assembled set, indicate the number of external cylinder assembled on one spline shaft. For an interchangeable external cylinder only, "C1" is indicated.

---

**5 Length of spline shaft**

Assembled set : R○  
Spline shaft only : R○

Indicate the length of spline shaft in mm. For standard and maximum length, see dimension table from page A-107 and A-109.

---

**6 Preload**

Standard : No symbol  
Light preload : T1

Specify this item for an assembled set or an interchangeable external cylinder. Applicable preload and size are shown in Table 3. For detail of preload amount, see Table 7 on page D-15.

---

**7 Accuracy class**

Ordinary : No symbol  
High class : H  
Precision class : P

The precision class (P) applies to non-interchangeable specification only.  
For interchangeable specification products, assemble external cylinder and a spline shaft of the same accuracy class. For details of accuracy classes, see page D-11.

**8** Interchangeable specification

Interchangeable code : S2 External cylinder and spline shaft can be supplied separately by interchangeable code S2.

**9** Optional specification

/N, /S For applicable optional specifications, see Table 2.

**Table 2 Special specifications**

Special specifications	Supplemental code	Applicable size
No end seal	/N <sup>(1)</sup>	5~12
Stainless steel spline shaft	/S <sup>(2) (3)</sup>	5~12

Note<sup>(1)</sup> : Applicable to interchangeable external cylinder and assembled set  
<sup>(2)</sup> : Applicable to non-interchangeable specification  
<sup>(3)</sup> : Not applicable to the hollow shaft.

**No end seal** /N

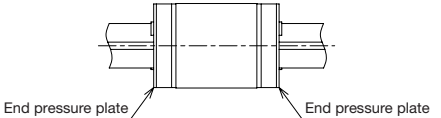

End seals at both ends of external cylinder are replaced by steel pressure plate. It does not contact to spline shaft in order to reduce frictional resistance. This is not effective for dust protection.

**Stainless steel spline shaft** /S

The material of the solid spline shaft is changed to stainless steel. The load rating will be a value obtained by multiplying the load rating for the high carbon steel spline shaft by a factor of 0.8.

**Moment of inertia of sectional area and section modulus of spline shaft**

Moment of inertia of sectional area and section modulus of the spline shaft are shown in Table 3.

**Table 3 Moment of inertia of sectional area and section modulus**

Model number	Moment of inertia of sectional area mm <sup>4</sup>		Section modulus mm <sup>3</sup>	
	Solid shaft	Hollow shaft	Solid shaft	Hollow shaft
<b>MAG 5</b>	29	29	12	12
<b>MAG 6</b>	61	61	21	21
<b>MAG 8</b>	190	190	49	49
<b>MAG 10</b>	470	460	95	94
<b>MAG 12</b>	990	960	170	160

Remark : The table shows representative model numbers only but is applicable to all models of the same size.

**Dimensions of key**

The sunk keys shown in Table 4 are provided with the external cylinder.

**Table 4 Dimensions and tolerance of attached key**

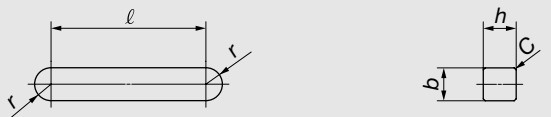

unit : mm

Model number	b	Tolerance	h	Tolerance	l	r	C
<b>MAG 5</b>	2	+0.016 +0.006	2	0 -0.025	3.8	1	0.16~0.25
<b>MAG 6</b>			2.5		5.8		
<b>MAG 8</b>	3	7.8	1.5				
<b>MAG 10</b>	3	11.8					
<b>MAG 12</b>							

Remark : The table shows representative model numbers only but is applicable to all other models in the same size.

**Others**

Load rating, Accuracy, Pleoad, Lubrication, Dust protection, Precautions for use and mounting, please refer D-8.

# IKO C-Lube Linear Ball Spine MAG : Standard type

## MAG • MAGT



Bore dia. of hollow shaft of MAGT

Model number	Interchangeable	Mass (Ref.) g		Dimension and tolerances of external cylinder mm								d	Tolerance
		External cylinder	Spline shaft (per 100 mm)	D	Tolerance	L1	L2	W	Tolerance	t	ℓ		
MAG 5	☆	4.8	14.9	10	0 -0.009	18	9.4	2	+0.014 0	1.2	6	5	0 -0.012
MAGT 5	☆		12.4										
MAG 6	☆	8.9	19	12	0 -0.011	21	12.4	2	+0.014 0	1.2	8	6	0 -0.012
MAGT 6	☆		16.5										
MAG 8	☆	15.9	39	15	0 -0.011	25	14.6	2.5	+0.014 0	1.5	8.5	8	0 -0.015
MAGT 8	☆		33										
MAG 10	☆	31.5	60.5	19	0 -0.013	30	18.2	3	+0.014 0	1.8	11	10	0 -0.015
MAGT 10	☆		51										
MAG 12	☆	44	87.5	21	0 -0.013	35	23	3	+0.014 0	1.8	15	12	0 -0.018
MAGT 12	☆		66										

Note<sup>(1)</sup>: Dimension  $d_1$  indicates the maximum diameter when machining is done at the shaft ends.

<sup>(2)</sup>: Lengths indicated are standard length. Spline shafts in different lengths are also available. Simply indicate the necessary length of spline shaft (mm) in the identification number.

<sup>(3)</sup>: The directions of dynamic load rating (C), basic static load rating ( $C_0$ ), dynamic torque rating (T) and static torque/moment rating ( $T_0$ ,  $T_x$  and  $T_y$ ) are shown in the sketches below.

The upper values in the  $T_x$  and  $T_y$  columns apply to one external cylinder, and the lower values apply to two external cylinders in close contact.

Remark: The mark ☆ indicates that interchangeable specification products are available.

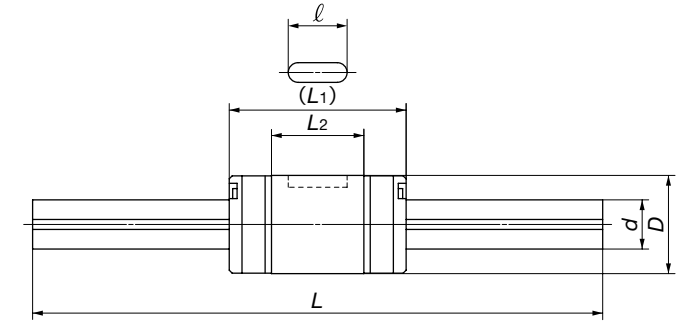
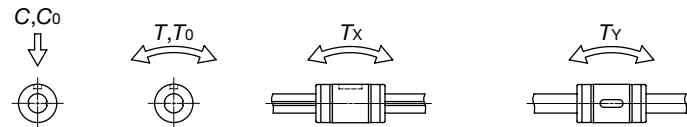

Dimension of spline shaft mm				Basic dynamic load rating <sup>(3)</sup>	Basic static load rating <sup>(3)</sup>	Dynamic torque rating <sup>(3)</sup>	Static torque rating <sup>(3)</sup>	Static moment rating <sup>(3)</sup>	
$d_1$ <sup>(1)</sup>	$d_2$	$L$ <sup>(2)</sup>	Maximum length	C N	$C_0$ N	T N·m	$T_0$ N·m	$T_x$ N·m	$T_y$ N·m
4.2	— 2	100 150	200	587	641	1.8	1.9	1.0 7.9	1.8 13.6
5.2	— 2	150 200	300	711	855	2.5	3.0	1.7 11.7	3.0 20.3
7	— 3	150 200 250	500 400	1 190	1 330	5.5	6.2	3.3 22.0	5.6 38.1
8.9	— 4	200 300	600	1 880	2 150	10.9	12.5	7.0 41.5	12.1 71.9
10.9	— 6	200 300 400	800	2 180	2 690	14.8	18.3	10.6 59.1	18.3 102

Example of identification number of assembled set (For details, see "Identification number and specification".)

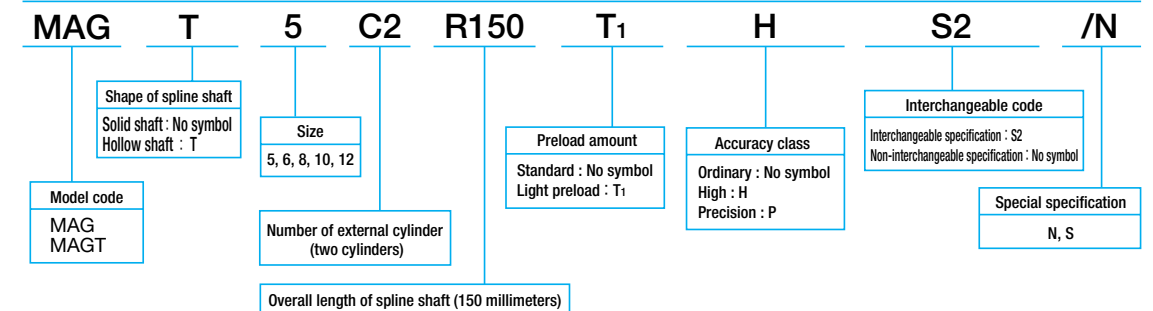



## MAGF • MAGFT

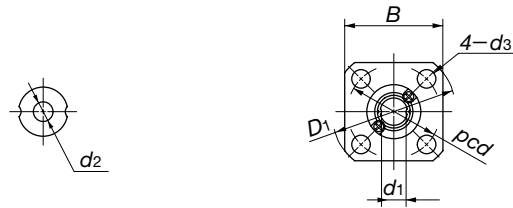

Bore dia. of hollow shaft of MAGT

Model number	Interchangeable	Mass (Ref.) g		Dimension and tolerance of external cylinder mm										d	Tolerance
		External cylinder	Spline shaft (per 100 mm)	D	Tolerance	L <sub>1</sub>	L <sub>2</sub>	D <sub>1</sub>	B	E	T	pcd	d <sub>3</sub>		
MAGF 5	☆	8.9	14.9	10	0 -0.009	18	9.4	23	18	7	2.7	17	3.4	5	0 -0.012
MAGFT 5	☆		12.4												
MAGF 6	☆	13.9	19	12	0 -0.011	21	12.4	25	20	7	2.7	19	3.4	6	0 -0.012
MAGFT 6	☆		16.5												
MAGF 8	☆	23.5	39	15	0 -0.011	25	14.6	28	22	9	3.8	22	3.4	8	0 -0.015
MAGFT 8	☆		33												
MAGF 10	☆	45	60.5	19	0 -0.013	30	18.2	36	28	10	4.1	28	4.5	10	0 -0.015
MAGFT 10	☆		51												
MAGF 12	☆	59	87.5	21	0 -0.013	35	23	38	30	10	4	30	4.5	12	0 -0.018
MAGFT 12	☆		66												

Note<sup>(1)</sup>: Dimension d<sub>1</sub> indicates the maximum diameter when machining is done at the shaft ends.

(2): Lengths indicated are standard length. Spline shafts in different lengths are also available. Simply indicate the necessary length of spline shaft (mm) in the identification number.

(3): The directions of dynamic load rating (C), basic static load rating (C<sub>0</sub>), dynamic torque rating (T) and static torque/moment rating (T<sub>0</sub>, T<sub>x</sub> and T<sub>y</sub>) are shown in the sketches below.

The upper values in the T<sub>x</sub> and T<sub>y</sub> columns apply to one external cylinder, and the lower values apply to two external cylinders in close contact.

Remark: The mark ☆ indicates that interchangeable specification products are available.

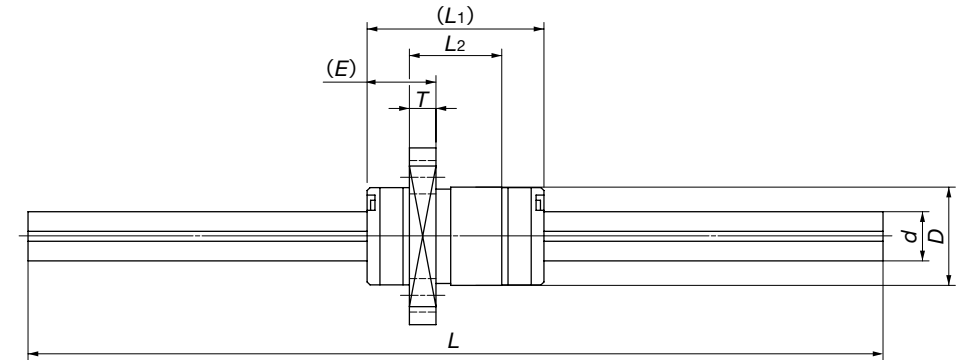
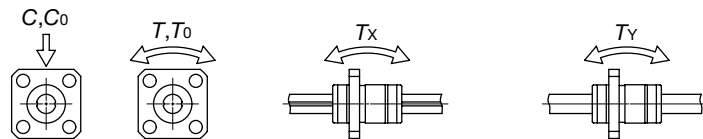

Dimension of spline shaft mm				Basic dynamic load rating <sup>(3)</sup> C N	Basic static load rating <sup>(3)</sup> C <sub>0</sub> N	Dynamic torque rating <sup>(3)</sup> T N·m	Static torque rating <sup>(3)</sup> T <sub>0</sub> N·m	Static moment rating <sup>(3)</sup>	
d <sub>1</sub> <sup>(1)</sup>	d <sub>2</sub>	L <sup>(2)</sup>	Maximum length					T <sub>x</sub> N·m	T <sub>y</sub> N·m
4.2	—	100 150	200	587	641	1.8	1.9	1.0	1.8
	2							7.9	13.6
5.2	—	150 200	300	711	855	2.5	3.0	1.7	3.0
	2							11.7	20.3
7	—	150 200 250	500	1 190	1 330	5.5	6.2	3.3	5.6
	3		400					22.0	38.1
8.9	—	200 300	600	1 880	2 150	10.9	12.5	7.0	12.1
	4							41.5	71.9
10.9	—	200 300 400	800	2 180	2 690	14.8	18.3	10.6	18.3
	6							59.1	102

Example of identification number of assembled set (For details, see "Identification number and specification".)

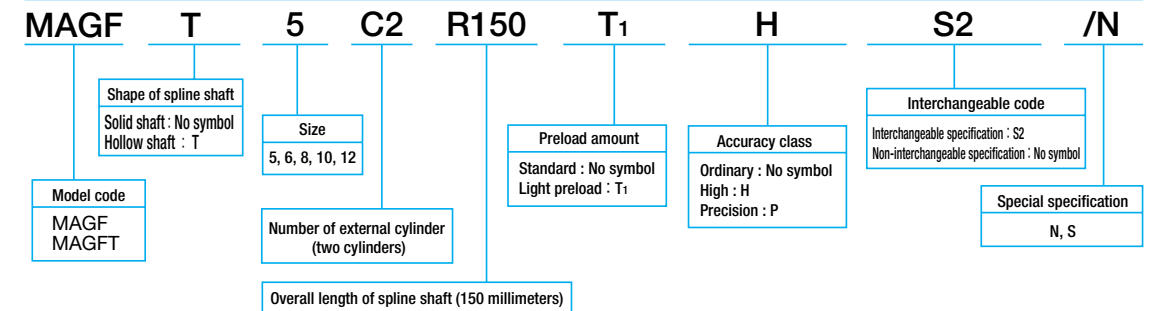



# Linear Ways

Description of each series and Table of dimensions

# B

## Linear Way L

Page B-2 to B-29



## Linear Way E

Page B-30 to B-55

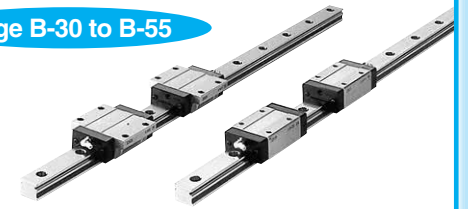

## Low Decibel Linear Way E

Page B-56 to B-73



## Linear Way H

Page B-74 to B-109

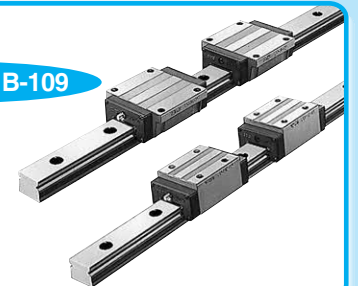

## Linear Way F

Page B-110 to B-129



## Linear Way U



Page B-130 to B-141

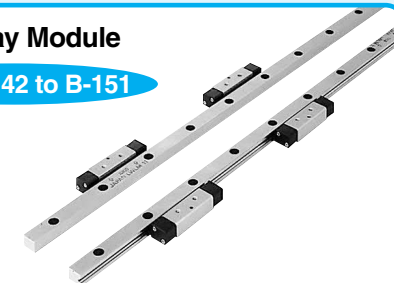

## Linear Way Module

Page B-142 to B-151



In the table of dimensions, standard products are referred to using identification numbers marked with . The identification numbers marked with  refer to our semi-standard products.

# Linear Way L

LWL/LWLF

**IKO** Linear Way L is a miniature type linear motion rolling guide, incorporating two rows of steel balls arranged in four point contact with the raceways. Although it is small in size, it provides stable accuracy and rigidity owing to its simple design even in operations under fluctuating loads with changing direction and magnitude or complex loads. The standard products are made from stainless steel, and a wide range of variations in shapes and sizes are available for selections suitable for each application.

## Interchangeable

The ball-retained type includes interchangeable specification products. The dimensions of slide units and track rails of this specification are individually controlled, so that the slide units and track rails can be combined, added or exchanged freely.

## Standard type and wide rail type

Slide units and track rails are provided in two widths: standard type and wide rail type. The wide rail type is suitable for single row rail arrangement.

## Length of slide unit

The slide unit of stainless steel, ball retained type is further classified into three types: short type, standard type and high rigidity long type. All of these slide units are equal in sectional dimensions but different in slide unit lengths, which can be selected suiting the requirements in each application.

## Stainless steel type and high carbon steel type

The stainless steel type has excellent corrosion resistance and is most suitable for machines and equipment used in clean environments, for example, medical equipment, disk read devices, and semiconductor manufacturing equipment. The high carbon steel type permits additional working to track rails and is used for general purpose applications such as material transfer machines and handling equipment.

## Ball retained type

The slide unit of ball retained type incorporates ball retaining bands, which prevent steel balls from dropping when the slide unit is separated from the track rail. So handling is easy.

## Tapped rail specification

In addition to the standard specification track rail which is fixed by inserting bolts downward in the mounting holes, the tapped rail specification track rail that has tapped screw holes is available, so an optimum mounting direction can be selected, giving more freedom in machine design.

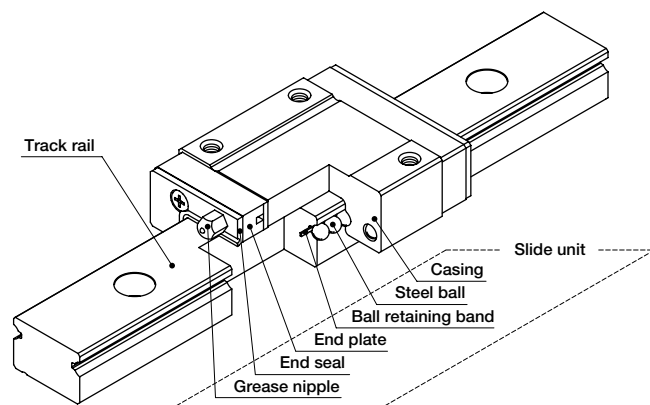

Structure of Linear Way L Ball Retained Type

U.S. PATENT No. 5,435,649  
 No. 5,289,779  
 No. 5,250,126  
 No. 4,652,147  
 No. 4,505,522

## Linear Way L series

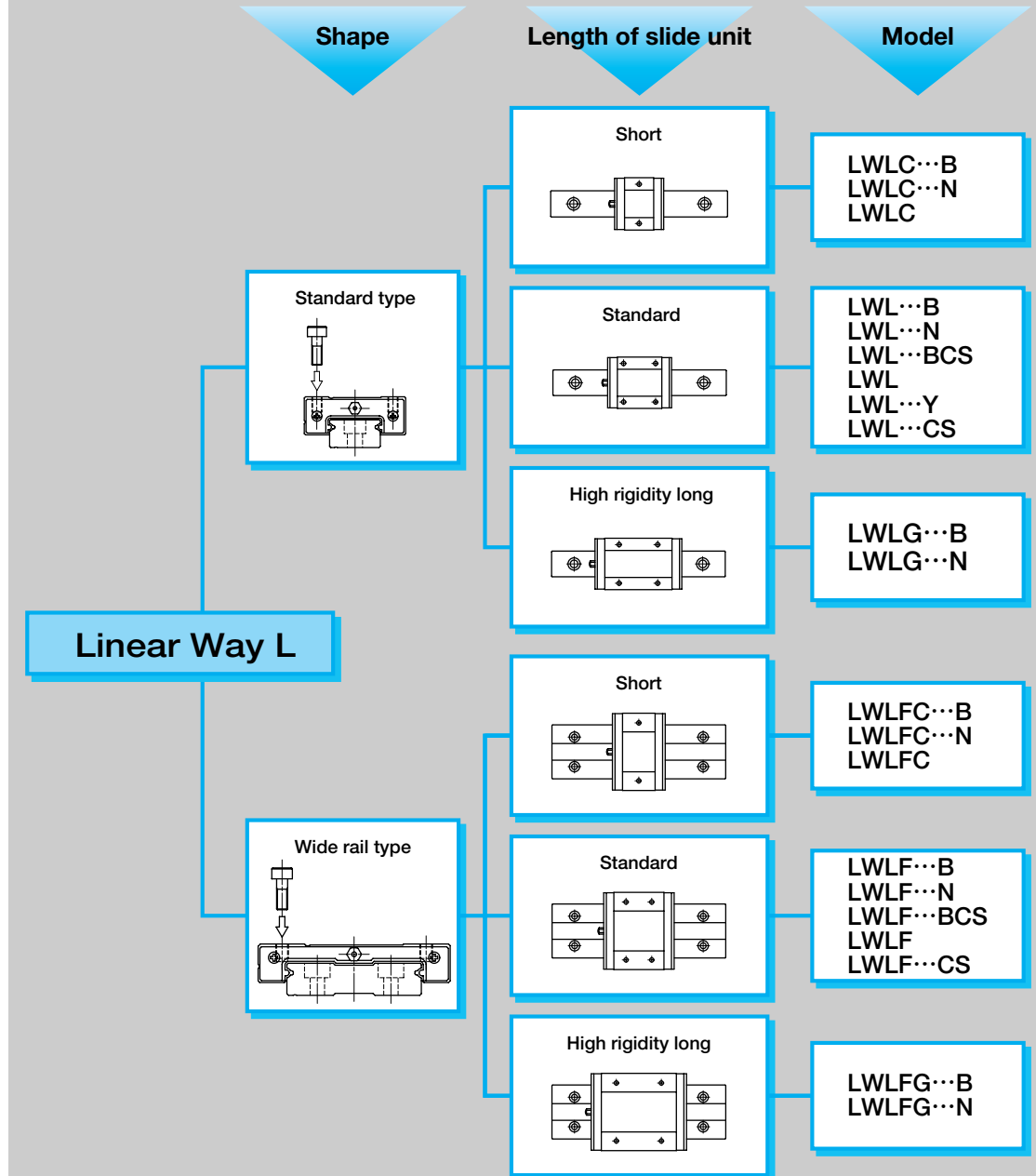

Remark 1 : Models with "B" are ball retained type and include interchangeable products.  
 2 : Models with "N" or "Y" are tapped rail specification.  
 3 : Models with "CS" are high carbon steel type.

## Identification number and specification

The specification of Linear Way L is indicated by the identification number, consisting of a model code, a size, a part code, a material symbol, a preload symbol, a classification symbol, an interchangeable code and any supplemental codes. For details of each specification, see page 78.

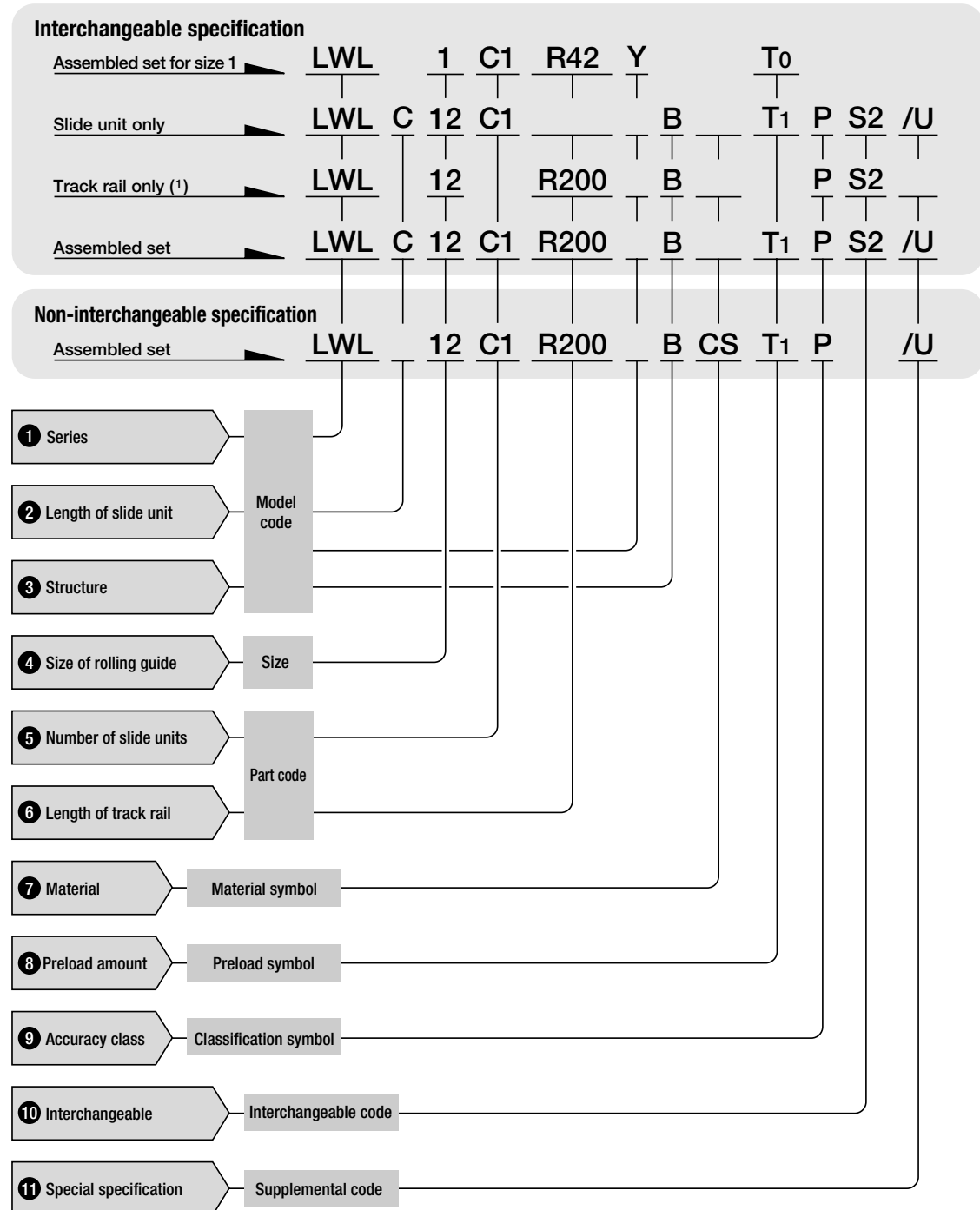

Note(1) : For the model code of a single track rail of interchangeable specification, indicate "LWL...B" or "LWLF...B" regardless of the slide unit type to be combined.

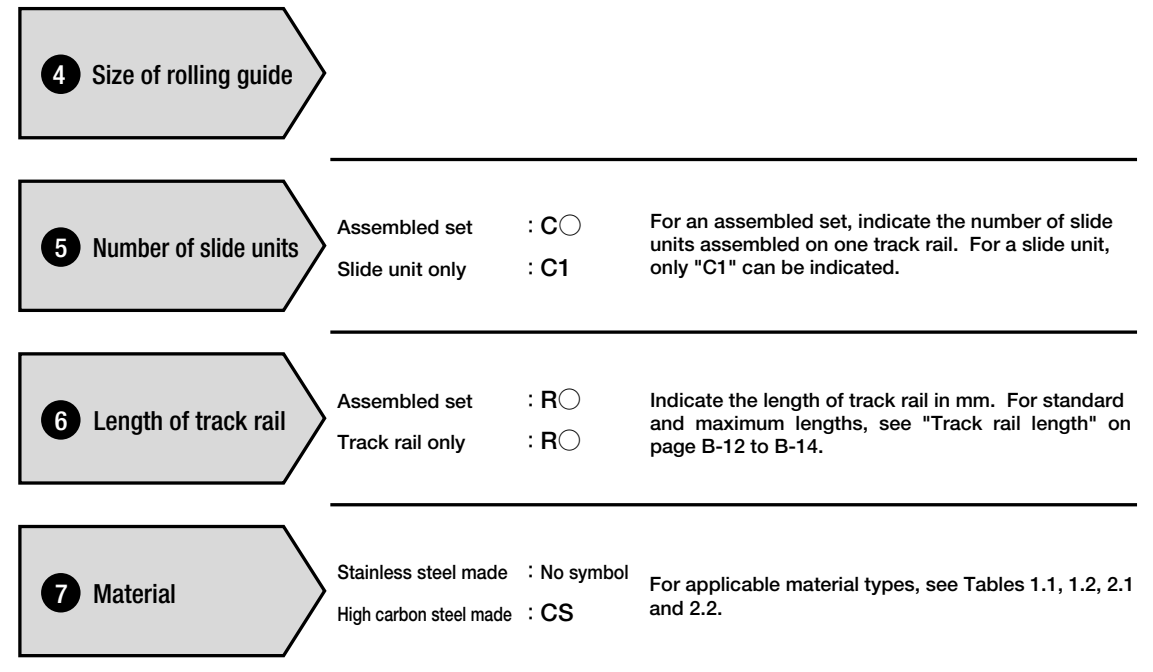
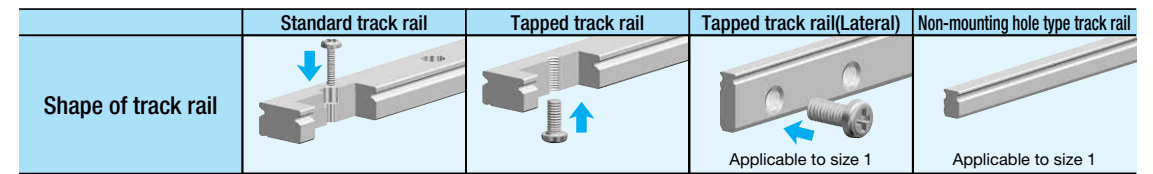
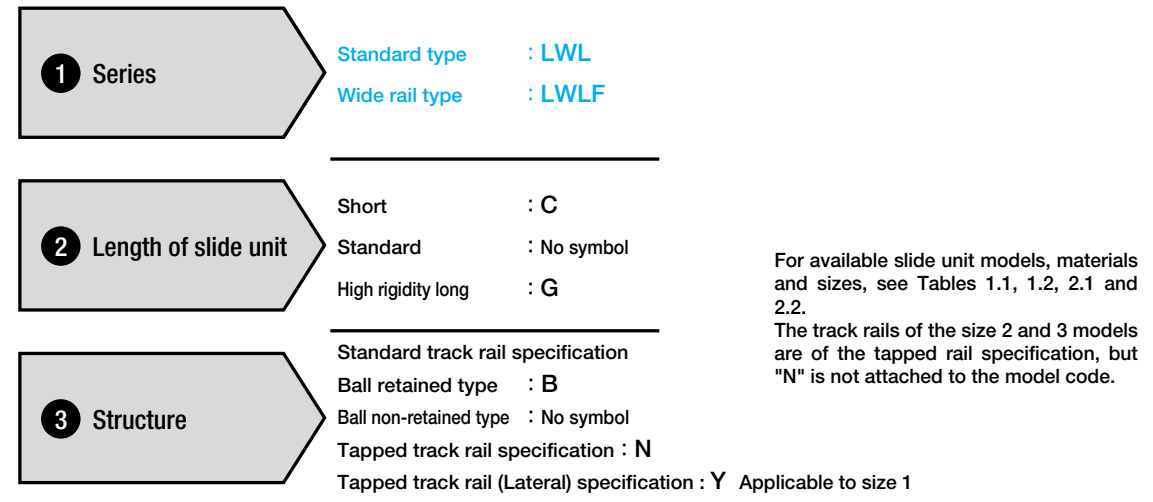

Table 1.1 Models and sizes of Linear Way L standard type (Ball retained type)

Model Size	Standard track rail specification				Tapped track rail specification		
	Stainless steel made			High carbon steel made	Stainless steel made		
	Short LWLC···B	Standard LWL···B	High rigidity long LWLG···B	Standard LWL···BCS	Short LWLC···N	Standard LWL···N	High rigidity long LWLG···N
5	☆	☆	—	—	○	○	—
7	☆	☆	☆	—	○	○	○
9	☆	☆	☆	☆	○	○	○
12	☆	☆	☆	☆	—	—	—
15	☆	☆	☆	☆	—	—	—
20	☆	☆	☆	☆	—	—	—
25	☆	☆	☆	—	—	—	—

Remark : The mark ☆ indicates that interchangeable specification products are available.

Table 1.2 Models and sizes of Linear Way L standard type (Ball non-retained type)

Model Size	Standard track rail specification		Tapped track rail specification			Non-mounting hole track rail specification
	Stainless steel made	High carbon steel made	Stainless steel made			Stainless steel made
	Standard LWL	Standard LWL···CS	Short LWLC	Standard LWL	Standard LWL···Y	Standard LWL
1	—	—	—	—	○	○
2	—	—	—	○	—	—
3	—	—	○	○	—	—
5	○	—	—	—	—	—
7	○	—	—	—	—	—
9	○	—	—	—	—	—
12	○	○	—	—	—	—
15	○	○	—	—	—	—

Table 2.1 Models and sizes of Linear Way L wide rail type (Ball retained type)

Model Size	Standard track rail specification				Tapped track rail specification		
	Stainless steel made			High carbon steel made	Stainless steel made		
	Short LWLFC···B	Standard LWLF···B	High rigidity long LWLF···CS	Standard LWLF···BCS	Short LWLFC···N	Standard LWLF···N	High rigidity long LWLF···N
10	☆	☆	—	—	○	○	—
14	☆	☆	☆	—	○	○	○
18	☆	☆	☆	☆	○	○	○
24	☆	☆	☆	☆	—	—	—
30	☆	☆	☆	☆	—	—	—
42	☆	☆	☆	☆	—	—	○

Remark : The mark ☆ indicates that interchangeable specification products are available.

Table 2.2 Models and sizes of Linear Way L wide rail type (Ball non-retained type)

Model Size	Standard track rail specification			Tapped track rail specification	
	Stainless steel made		High carbon steel made	Stainless steel made	
	Short LWLFC	Standard LWLF	Standard LWLF···CS	Short LWLFC···N	Standard LWLF···N
4	—	○	—	—	—
6	○	○	—	○	○
14	—	○	—	—	—
18	—	○	○	—	—
24	—	○	○	—	—
42	—	○	○	—	—

8 Preload amount

Clearance : T0  
 Standard : No symbol  
 Light preload : T1  
 Specify this item for an assembled set or a single slide unit. For applicable preload amount, see Table 3. For details of preload amount, see page 86.

Table 3 Applicable preload types

Standard type	Wide rail type	Preload type		
		Clearance (T0)	Standard (No symbol)	Light preload (T1)
1	—	○	—	—
2	4	○	—	—
3	6	○	—	—
5	10	☆	☆	—
7	14	☆	☆	☆
9	18	☆	☆	☆
12	24	☆	☆	☆
15	30	☆	☆	☆
20	42	☆	☆	☆
25	—	☆	☆	☆

Remark : The mark ☆ indicates that it is also applicable to interchangeable specification products.

9 Accuracy class

High : H  
 Precision : P  
 For the interchangeable specification, combine slide units and track rails of the same class. For details of accuracy, see page 81.  
 ※Accuracy class is not applicable to size 1.

10 Interchangeable code

Interchangeable : S2  
 In Linear Way L, slide unit and track rail can be supplied separately by indicating interchangeable code S2.

11 Special specification

For applicable special specifications, see Table 4. When several special specifications are required, see Table 5. Special specifications are not applicable to size 1. For details of special specifications, see page 88.

Table 4 Special specifications

Special specification	Supplemental code	Assembled set	Track rail only	Slide unit only	Dimension
Butt-jointing track rail	A	○ <sup>(1)</sup> ( <sup>2</sup> )( <sup>3</sup> )	—	—	
Stainless steel end plates	BS	○ <sup>(4)</sup>	—	—	
Opposite reference surfaces arrangement	D	☆	—	—	
Specified rail mounting hole positions	E	☆	☆	—	
Inspection sheet	I	○	—	—	
Black chrome surface treatment (track rail)	LR	○ <sup>(5)</sup>	—	—	
Supplied without track rail mounting bolt	MN	☆ <sup>(2)</sup> ( <sup>6</sup> )	☆	—	
No end seal	N	☆	—	☆	
Capillary plates	Q	☆	—	☆	See Table 7.
Seals for special environment	RE	○ <sup>(7)</sup>	—	—	
Track rail with stopper pins	S	○	—	—	See Table 8.
Under seals	U	☆ <sup>(8)</sup>	—	☆ <sup>(9)</sup>	See Table 9.
Matched sets to be used as an assembled group	W	○	—	—	
Specified grease	Y	○ <sup>(10)</sup>	—	—	

Note<sup>(1)</sup> : Not applicable to high carbon steel type.  
<sup>(2)</sup> : Not applicable to tapped rail specification products.  
<sup>(3)</sup> : Not applicable to size 2, 3, 4 and 6 models.  
<sup>(4)</sup> : Not applicable to size 25 models.  
<sup>(5)</sup> : Not applicable to size 2, 3, 4, 5, 6 and 10 models.  
<sup>(6)</sup> : Not applicable to size 2 and 3 models.  
<sup>(7)</sup> : Not applicable to size 2, 3, 4 and 25 models.  
<sup>(8)</sup> : Not applicable to size 2, 3, 4, 5, 6, 7, 10 and 14 models.  
<sup>(9)</sup> : Not applicable to size 5, 7, 10 and 14 models.  
<sup>(10)</sup> : Only /YNG is applicable to size 2 and 4 models.  
Remarks 1 :The mark ☆ indicates that it is also applicable to interchangeable specification products.  
2 :Not applicable to size 1.

Table 5 Combination of special specifications

BS	○																				
D	○	○																			
E	—	○	—																		
I	○	○	○	○																	
LR	—	○	○	○	○																
MN	○	○	☆	☆	○	○															
N	○	○	☆	☆	○	○	☆														
Q	○	○	☆	☆	○	○	☆	☆													
RE	○	○	○	○	○	○	○	○	—	○											
S	○	○	○	○	○	○	○	○	○	○											
U	○	○	☆	☆	○	○	☆	—	☆	—	○										
W	○	○	○	—	○	○	○	○	○	○	○	○									
Y	○	○	○	○	○	○	○	○	○	—	○	○	○	○							
	A	BS	D	E	I	LR	MN	N	Q	RE	S	U	W								

Remark 1 : In the table, the mark ☆ indicates that it is also applicable to interchangeable specification products.  
2 : In the table, the mark — indicates that this combination cannot be made.  
3 : When several special specifications are combined, arrange the supplemental codes alphabetically.

Table 7 Slide unit with Capillary plates (Supplemental code /Q)

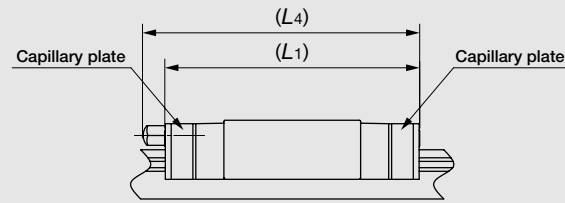

unit : mm

Model number	L1	L4	Model number	L1	L4
LWLC 5...B	22	—	LWLFC 10...B	26.5	—
LWL 5...B	25	—	LWLF 10...B	30.5	—
LWLC 7...B	27	—	LWLFC 14...B	30.5	—
LWL 7...B	31.5	—	LWLF 14...B	39.5	—
LWLG 7...B	39	—	LWLFG 14...B	50	—
LWLC 9...B	30	—	LWLFC 18...B	34.5	—
LWL 9...B	39	—	LWLF 18...B	47	—
LWLG 9...B	49	—	LWLFG 18...B	58.5	—
LWLC 12...B	33	—	LWLFC 24...B	38.5	—
LWL 12...B	42	—	LWLF 24...B	52	—
LWLG 12...B	52	—	LWLFG 24...B	67	—
LWLC 15...B	42	46	LWLFC 30...B	45.5	50
LWL 15...B	52	57	LWLF 30...B	60	64
LWLG 15...B	67	72	LWLFG 30...B	78.5	83
LWLC 20...B	48	52	LWLFC 42...B	51.5	56
LWL 20...B	60	65	LWLF 42...B	65	70
LWLG 20...B	78	82	LWLFG 42...B	84.5	89
LWLC 25...B	63.5	74			
LWL 25...B	87.5	98			
LWLG 25...B	107.5	118			

Remark : The above table shows representative model numbers but is applicable to all models.

Table 8 Track rail with stopper pins (Supplemental code /S)

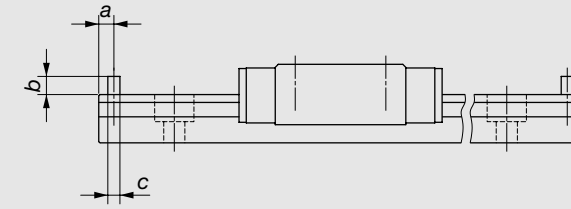

unit : mm

Model number	a	b	c	Model number	a	b	c
Ball retained type				Ball retained type			
LWL 5...B	2	2	1.6	LWLF 10...B	2.5	2	1.6
LWL 7...B	2.5	2.5	2	LWLF 14...B		3	2
LWL 9...B		3					
LWL 12...B		4					
LWL 15...B		5					
LWL 20...B		3.5		5			
LWL 25...B				LWLF 18...B	4	2	
				LWLF 24...B			
				LWLF 30...B			
				LWLF 42...B	5		

Remark : The above table shows representative model numbers but is also applicable to all models of the same size.

Table 9 H<sub>1</sub> dimension of slide unit with under seals (Supplemental code /U)

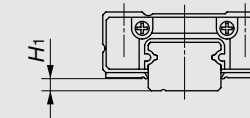

unit : mm

Model number	H <sub>1</sub>	Model number	H <sub>1</sub>
Ball retained type		Ball retained type	
LWL 9...B	1	LWLF 18...B	2
LWL 12...B	2	LWLF 24...B	
LWL 15...B	3	LWLF 30...B	
LWL 20...B	4	—	
LWL 25...B	5(1)	LWLF 42...B	3

Note(1) : This dimension is the same as that without under seals.

Remark : The above table shows representative model numbers but is applicable to all models of the same size.



## Track rail length

Standard and maximum lengths of track rails are shown in Tables 10.1, 10.2 and 10.3. Track rails in any length are also available. Simply indicate the necessary length of track rail in mm in the identification number. For the tolerances of *E* dimension and track rail length, consult **IKO** for further information.

- For non-interchangeable track rails longer than the maximum length shown in Tables 10.1, 10.2 and 10.3, butt-jointing track rails are available upon request. In this case, indicate " / A " in the identification number.
- *E* dimensions at both ends are the same and are within the standard range of *E* unless otherwise specified. To change these dimensions, specify the specified rail mounting hole positions " / E " of special specification. For details, see page 91.

Table 10.1 Standard and maximum lengths of stainless steel track rails (Standard type)

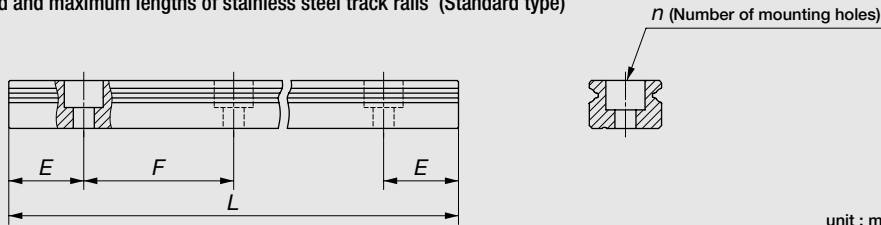

Item	Model number					
	LWL 1...Y	LWL 1	LWL 2	LWL 3	LWL 5...B LWL 5	LWL 7...B LWL 7
Standard length <i>L</i> (n)	18( 3)	18(—)	32( 4)	30( 3)	60( 4)	60( 4)
	30( 5)	30(—)	40( 5)	40( 4)	90( 6)	90( 6)
	42( 7)	42(—)	56( 7)	60( 6)	105( 7)	120( 8)
			80(10)	80( 8)	120( 8)	150(10)
Pitch of mounting holes <i>F</i>	6	—	8	10	15	15
<i>E</i>	3	—	4	5	7.5	7.5
Standard range of <i>E</i> (1)	incl.	2.5	—	2.5	3	4
	under	5.5	—	6.5	8	11.5
Maximum length(2)	102	102	104 (200)	150 (300)	210 (510)	300 (990)
Maximum number of butt-jointing track rails	—	—	—	—	5	7
Maximum length of butt-jointing track rails	—	—	—	—	915	1 905
Item	Model number					
	LWL 9...B LWL 9	LWL 12...B LWL 12	LWL 15...B LWL 15	LWL 20...B	LWL 25...B	
Standard length <i>L</i> (n)	60( 3)	100( 4)	160( 4)	180( 3)	240( 4)	
	80( 4)	150( 6)	240( 6)	240( 4)	300( 5)	
	120( 6)	200( 8)	320( 8)	360( 6)	360( 6)	
	160( 8)	275(11)	440(11)	480( 8)	480( 8)	
	220(11)	350(14)	560(14)	660(11)	660(11)	
	280(14)	475(19)	680(17)	840(14)	900(15)	
Pitch of mounting holes <i>F</i>	20	25	40	60	60	
<i>E</i>	10	12.5	20	30	30	
Standard range of <i>E</i> (1)	incl.	4.5	5	5.5	8	9
	under	14.5	17.5	25.5	38	39
Maximum length(2)	860 (1 200)	1 000 (1 450)	1 000 (1 480)	960 (1 800)	960 (1 800)	
Maximum number of butt-jointing track rails	2	2	2	2	2	
Maximum length of butt-jointing track rails	1 660	1 925	1 880	1 740	1 740	

unit : mm

Note(1) : Not applicable to the track rail with stopper pins (/S).

(2) : The track rails of LWL 2, LWL 3 and LWL ...B can be manufactured up to the maximum lengths shown in parentheses.

Consult **IKO** for further information.

Remark 1 : The above table shows representative model numbers but is applicable to all models of the same size.

2 : "Maximum number of butt-jointing track rails" and "Maximum length of butt-jointing track rails" do not apply to the track rails of interchangeable specification and tapped rail specification.

Table 10.2 Standard and maximum lengths of stainless steel track rails (Wide rail type)

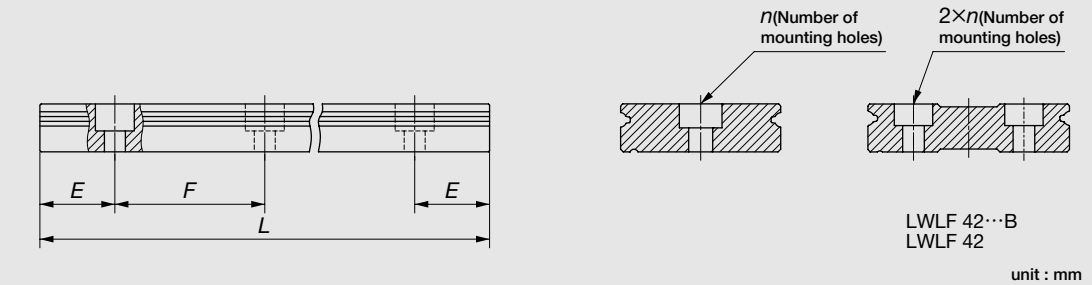

Item	Model number			
	LWLF 4	LWLF 6	LWLF 10...B	LWLF 14...B LWLF 14
Standard length <i>L</i> (n)	40( 4)	60( 4)	60( 3)	90( 3)
	60( 6)	90( 6)	80( 4)	120( 4)
	70( 7)	105( 7)	120( 6)	150( 5)
	80( 8)	120( 8)	160( 8)	180( 6)
	100(10)	150(10)	220(11)	240( 8)
			280(14)	300(10)
Pitch of mounting holes <i>F</i>	10	15	20	30
<i>E</i>	5	7.5	10	15
Standard range of <i>E</i> (1)	incl.	3.5	4.5	4.5
	under	8.5	12	14.5
Maximum length(2)	180 (300)	240 (300)	300 (500)	300 (990)
Maximum number of butt-jointing track rails	—	—	7	8
Maximum length of butt-jointing track rails	—	—	1 840	1 950
Item	Model number			
	LWLF 18...B LWLF 18	LWLF 24...B LWLF 24	LWLF 30...B	LWLF 42...B LWLF 42
Standard length <i>L</i> (n)	90( 3)	120( 3)	160( 4)	160( 4)
	120( 4)	160( 4)	240( 6)	240( 6)
	150( 5)	240( 6)	320( 8)	320( 8)
	180( 6)	320( 8)	440(11)	440(11)
	240( 8)	400(10)	560(14)	560(14)
	300(10)	480(12)	680(17)	680(17)
Pitch of mounting holes <i>F</i>	30	40	40	40
<i>E</i>	15	20	20	20
Standard range of <i>E</i> (1)	incl.	5.5	6.5	6.5
	under	20.5	26.5	26.5
Maximum length(2)	690 (1 860)	680 (1 960)	680 (2 000)	680 (2 000)
Maximum number of butt-jointing track rails	3	3	3	3
Maximum length of butt-jointing track rails	1 920	1 840	1 840	1 840

Note(1) : Not applicable to the track rail with stopper pins (/S).

(2) : The track rails of LWLF 4, LWLF 6 and LWLF ...B can be manufactured up to the maximum lengths shown in parentheses.

Consult **IKO** for further information.

Remark 1 : The above table shows representative model numbers but is applicable to all models of the same size.

2 : "Maximum number of butt-jointing track rails" and "Maximum length of butt-jointing track rails" do not apply to the track rails of interchangeable specification and tapped rail specification.

Table 10.3 Standard and maximum lengths of high carbon steel track rails (Standard type, Wide rail type)

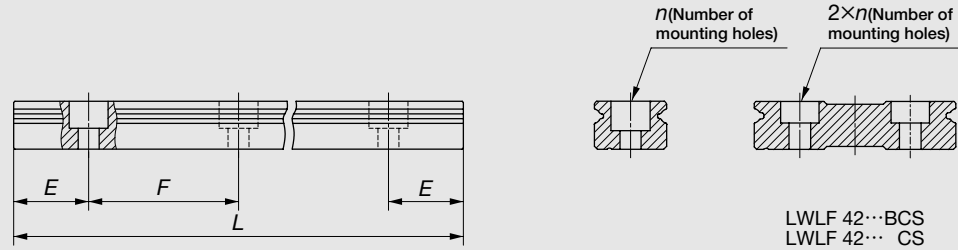

unit : mm

Model number	LWL 9...BCS	LWL 12...BCS LWL 12... CS	LWL 15...BCS LWL 15... CS	LWL 20...BCS
Item				
Standard length $L(n)$	80(4) 160(8) 220(11) 280(14) 380(19) 500(25) 600(30)	100(4) 200(8) 275(11) 350(14) 475(19) 600(24) 700(28)	160(4) 320(8) 440(11) 560(14) 680(17) 800(20) 920(23)	180(3) 240(4) 360(6) 480(8) 660(11) 900(15) 1 020(17)
Pitch of mounting holes $F$	20	25	40	60
$E$	10	12.5	20	30
Standard range of $E^{(1)}$	incl.	4.5	5	5.5
	under	14.5	17.5	25.5
Maximum length	1 000	1 500	1 520	1 560
Model number	LWLF 18...BCS LWLF 18... CS	LWLF 24...BCS LWLF 24... CS	LWLF 30...BCS	LWLF 42...BCS LWLF 42... CS
Item				
Standard length $L(n)$	90(3) 180(6) 240(8) 300(10) 420(14) 510(17) 600(20)	120(3) 240(6) 320(8) 400(10) 600(15) 720(18) 800(20)	160(4) 320(8) 440(11) 560(14) 680(17) 800(20) 920(23)	160(4) 320(8) 440(11) 560(14) 680(17) 800(20) 920(23)
Pitch of mounting holes $F$	30	40	40	40
$E$	15	20	20	20
Standard range of $E^{(1)}$	incl.	5.5	6.5	6.5
	under	20.5	26.5	26.5
Maximum length	1 500	1 520	1 600	1 600

Note(1) : Not applicable to the track rail with stopper pins (/S).

Remark : The above table shows representative model numbers but is applicable to all models of the same size.

## Mounting bolt

Mounting bolts for the slide unit and the track rail of tapped rail specification are available as shown in Table 11.1 and 11.2. Consult **IKO** for further information.

Table 11.1 Cross recessed head screw for precision equipment

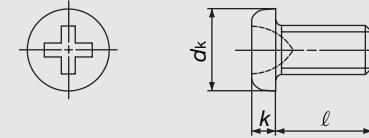

unit : mm

Bolt size ( $d$ )	Pitch of screw ( $P$ )	Dimension		
		$d_k$	$k$	$l$
<b>M1</b>	0.25	1.8	0.45	3, 4, 5
<b>M1.4</b> (1)	0.3	2.5	0.8	2.5, 3, 4
<b>M1.6</b> (1)	0.35	2.8	0.85	4, 5, 6
<b>M2</b> (1)	0.4	3.5	1	3, 4, 5

Note(1) : Based on "Cross recessed head screw (#0) for precision equipment" of Japanese Standard (JCS)10-70

Remark : Dimensions of the screws shown in the above table are different from those of the appended mounting bolts for track rail.

Table 11.2 Hexagon socket head bolt

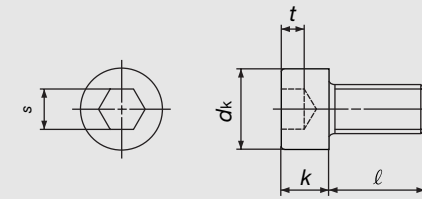

unit : mm

Bolt size ( $d$ )	Pitch of screw ( $P$ )	Dimension				
		$d_k$	$k$	$s$	$t$	$l$
<b>M1.4</b>	0.3	2.6	1.4	1.3	0.6	2.5, 3, 4
<b>M1.6</b> (1)	0.35	3	1.6	1.5	0.7	4, 5, 6
<b>M2</b> (1)	0.4	3.8	2	1.5	1	3, 4, 5

Note(1) : Based on JIS B 1176

Tapped track rail  
LWL ...Y  
Ball non-retained type  
LWLC  
LWL

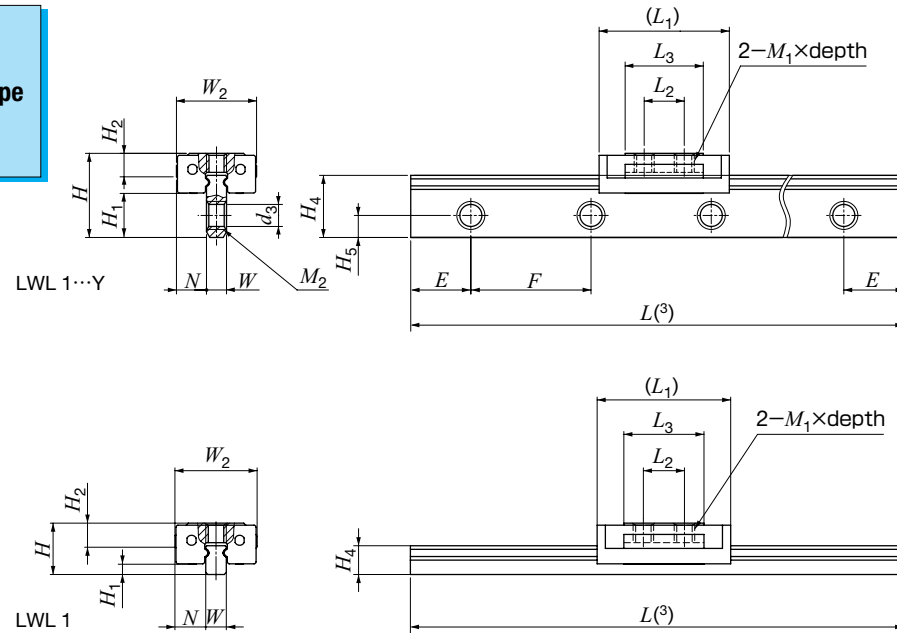

LWL 2  
LWLC 3  
LWL 3

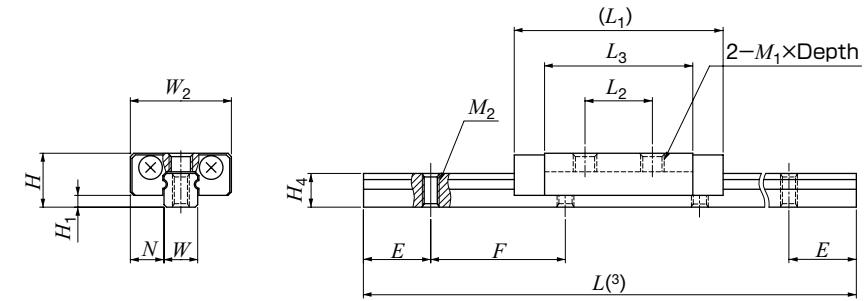

Model number	Mass(Ref.) g		Dimensions of assembly mm			Dimensions of side unit mm						
	Slide unit	Track rail (per 100 mm)	H	H <sub>1</sub>	N	W <sub>2</sub>	L <sub>1</sub>	L <sub>2</sub>	L <sub>3</sub>	M <sub>1</sub> × depth	H <sub>2</sub>	W
LWL 1...Y	0.16	2.1	4.2	2.2	1.5	4	6.5	2	3.9	M1 × 0.9	1.2	1
LWL 1		1.0	2.5	0.5								
LWL 2	0.9	2.8	3.2	0.7	2	6	12.4	4	8.8	M1.4 × 1.1	—	2
LWLC 3	1.0	5.3	4	1	2.5	8	12	3.5	6.7	M1.6 × 1.3	—	3
LWL 3	1.6											

Dimensions of track rail mm						Mounting bolt for track rail mm Bolt size × length	Basic dynamic load rating <sup>(4)</sup> C N	Basic static load rating <sup>(4)</sup> C <sub>0</sub> N	Static moment rating <sup>(4)</sup>		
H <sub>4</sub>	H <sub>5</sub>	M <sub>2</sub>	d <sub>3</sub>	E	F				T <sub>0</sub> N·m	T <sub>x</sub> N·m	T <sub>y</sub> N·m
3.1	1.1	M1.4 Through	1.1	3	6	M1 × ℓ or M1.4 × ℓ <sup>(1)</sup> (Not appended)	66.8	113	0.06	0.07 0.47	0.09 0.56
1.4	—	—	—	—	—	—					
2	—	M1 Through	—	4	8	M1 × ℓ <sup>(2)</sup> (Not appended)	211	381	0.42	0.54 2.9	0.64 3.4
2.6	—	M1.6 Through	—	5	10	M1.6 × ℓ <sup>(2)</sup> (Not appended)	251	361	0.58	0.39 2.9	0.47 3.4
							353	587	0.94	0.98 5.9	1.2 7.0

Note<sup>(1)</sup>: Prepare track rail mounting bolts according to mounting structure.

<sup>(2)</sup>: Fixing thread depth of bolt ℓ must be less than H<sub>4</sub>.

<sup>(3)</sup>: Track rail lengths are shown in Table 10.1 on page B-12.

<sup>(4)</sup>: The direction of basic dynamic load rating (C), basic static load rating (C<sub>0</sub>) and static moment rating (T<sub>0</sub>, T<sub>x</sub>, T<sub>y</sub>) are shown in the sketches below. The upper values in the T<sub>x</sub> and T<sub>y</sub> columns apply to one slide unit, and the lower values apply to two slide units in close contact.

Remarks 1: Metal parts are made of stainless steel.

2: Do not disassemble a slide unit from the track rail because steel balls are not retained. No end seal is attached.

3: For mounting slide unit, the bolts M1.6 or smaller are shown on page B-15. Consult IKO if required.

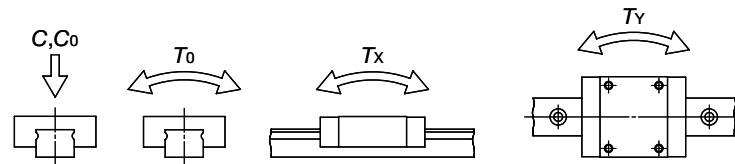

Example of identification number of assembled set (For details, see "Identification number and specification".)

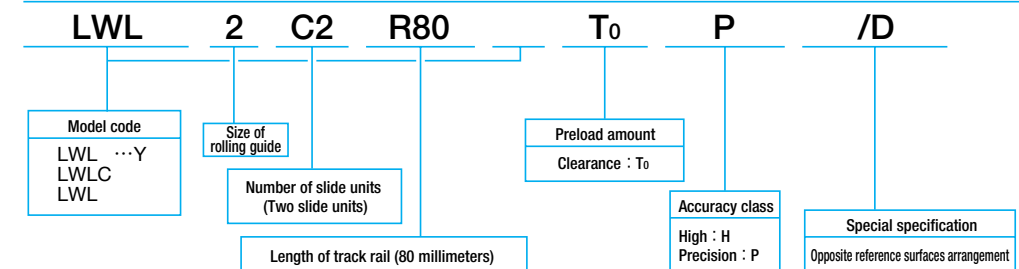

**Ball retained type**  
 LWLC...B  
 LWL ...B  
 LWLG...B  
**Tapped track rail**  
 LWLC...N  
 LWL ...N  
 LWLG...N  
**Ball non-retained type**  
 LWLC  
 LWL

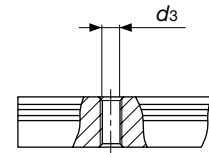
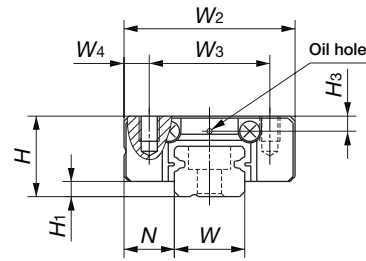

Tapped rail specification  
LWL...N

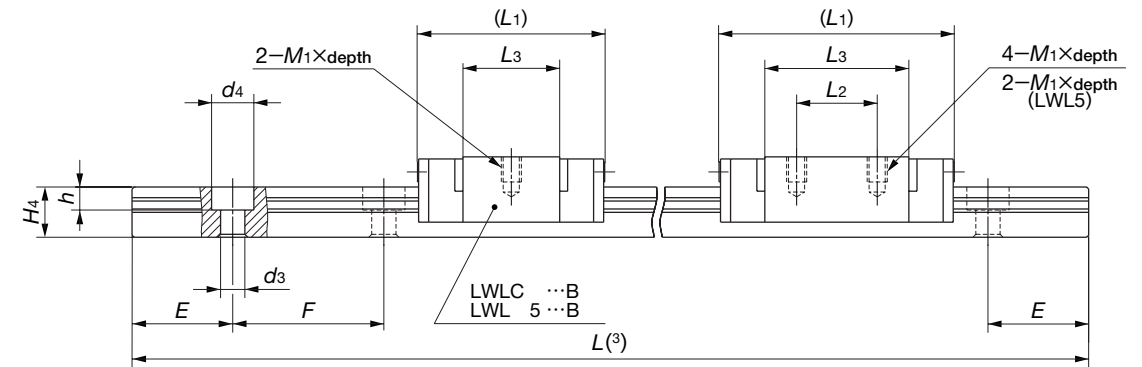

Model number	Interchangeable	Mass(Ref.) g		Dimensions of assembly mm			Dimensions of slide unit mm						
		Slide unit	Track rail (per 100 mm)	H	H <sub>1</sub>	N	W <sub>2</sub>	W <sub>3</sub>	W <sub>4</sub>	L <sub>1</sub>	L <sub>2</sub>	L <sub>3</sub>	M <sub>1</sub> × depth
LWLC 5...B	☆	3.4	12	6	1	3.5	12	8	2	16	-	9.6	M2 × 1.5
LWLC 5...N			13										
LWL 5...B	☆	4.4	12	6	1	3.5	12	8	2	19	-	12.6	M2 × 1.5
LWL 5...N			13										
LWLC 7...B	☆	7.1	22	6	1	3.5	12	8	2	19	-	9.6	M2 × 2.5
LWLC 7...N			24										
LWL 7...B	☆	10	22	6	1	3.5	12	8	2	23.5	8	14.3	M2 × 2.5
LWL 7...N			24										
LWLG 7...B	☆	14	22	6	1	3.5	12	8	2	31	12	21.6	M2 × 2.5
LWLG 7...N			24										

Note(1) : Prepare track rail mounting bolts with a fixing depth less than H<sub>4</sub>.

(2) : Track rail lengths are shown in Table 10.1 on page B-12.

(3) : The directions of basic dynamic load rating (C), basic static load rating (C<sub>0</sub>) and static moment rating (T<sub>0</sub>, T<sub>x</sub>, T<sub>y</sub>) are shown in the sketches below. The upper values in the T<sub>x</sub> and T<sub>y</sub> columns apply to one slide unit, and the lower values apply to two slide units in close contact.

Remark 1 : The mark ☆ indicates that interchangeable specification products are available.

2 : The appended bolts for mounting track rails are hexagon socket head bolts of JIS B 1176 or equivalent, or cross recessed head screws for precision equipment. For stainless steel type Linear Way L, stainless steel bolts or screws are appended.

3 : For mounting slide unit, the bolts M2 or smaller are shown on page B-15. Consult IKO for further information.

4 : The ball non-retained type models (LWL2, LWLC3, LWL3, LWL5, LWL7) are not provided with an oil hole.

5 : The specification of oil hole is shown on page 101.

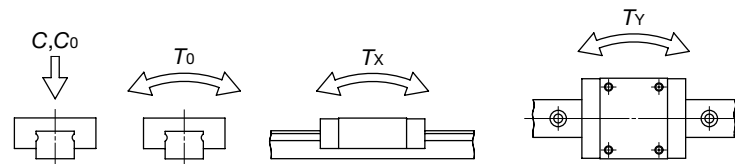

H <sub>3</sub>	Dimensions of track rail mm							Mounting bolt for track rail mm Bolt size × length	Basic dynamic load rating <sup>(4)</sup> C N	Basic static load rating <sup>(4)</sup> C <sub>0</sub> N	Static moment rating <sup>(4)</sup>		
	W	H <sub>4</sub>	d <sub>3</sub>	d <sub>4</sub>	h	E	F				T <sub>0</sub> N·m	T <sub>x</sub> N·m	T <sub>y</sub> N·m
1.2	5	3.7	2.4	3.6	0.8	7.5	15	Cross recessed head screw for precision equipment M2 × 6 M2.5 × ℓ <sup>(2)</sup> (Not appended)	562	841	2.2	1.4 8.5	1.2 7.2
			M2.5 Through	-	-			Cross recessed head screw for precision equipment M2 × 6 M2.5 × ℓ <sup>(2)</sup> (Not appended)					
1.5	7	5	2.4	4.2	2.3	7.5	15	Hexagon socket head bolt M2 × 6 M3 × ℓ <sup>(2)</sup> (Not appended)	937	1 140	4.1	1.8 14.9	1.5 12.5
			M3 Through	-	-			Hexagon socket head bolt M2 × 6 M3 × ℓ <sup>(2)</sup> (Not appended)					
			2.4	4.2	2.3			Hexagon socket head bolt M2 × 6 M3 × ℓ <sup>(2)</sup> (Not appended)					
			M3 Through	-	-			Hexagon socket head bolt M2 × 6 M3 × ℓ <sup>(2)</sup> (Not appended)					
			2.4	4.2	2.3			Hexagon socket head bolt M2 × 6 M3 × ℓ <sup>(2)</sup> (Not appended)	1 330	1 890	6.9	4.7 28.2	3.9 23.6
			M3 Through	-	-			Hexagon socket head bolt M2 × 6 M3 × ℓ <sup>(2)</sup> (Not appended)	1 690	2 650	9.7	8.8 50.7	7.4 42.5

Example of identification number of assembled set (For details, see "Identification number and specification".)

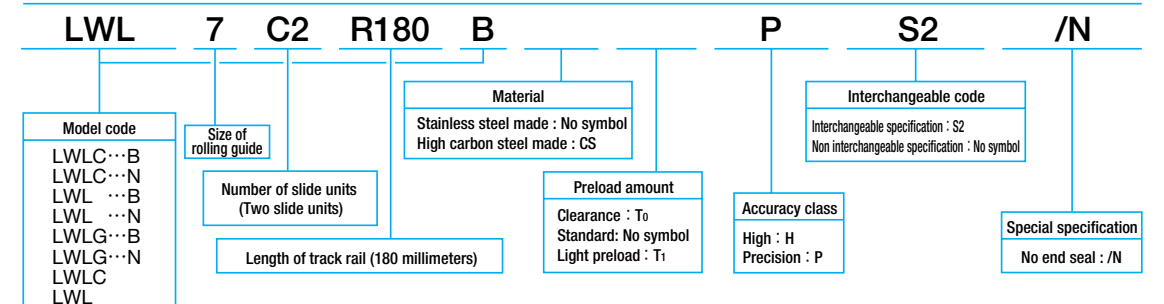

# IKO Linear Way L : Standard type

- Ball retained type**
- LWLC...B
- LWL ...B
- LWL ...B CS (High carbon steel made)
- LWLG...B
- Tapped track rail**
- LWLC...N
- LWL ...N
- LWLG...N
- Ball non-retained type**
- LWL
- LWL ...CS (High carbon steel made)

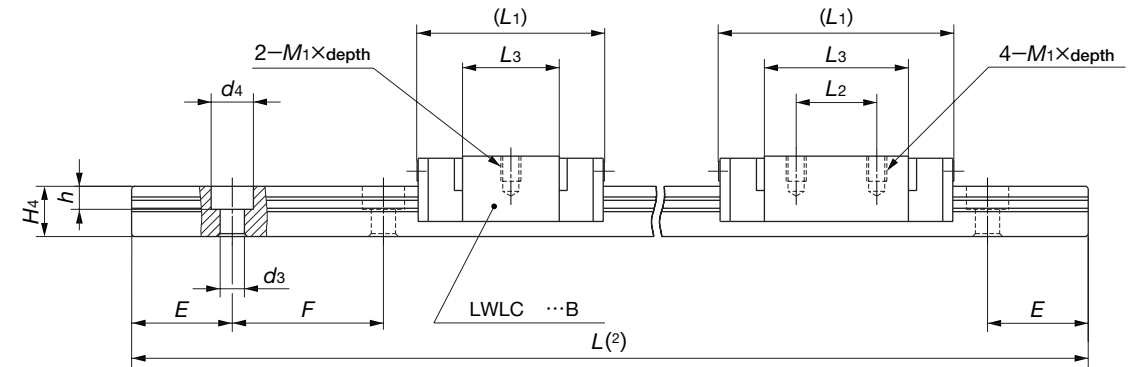
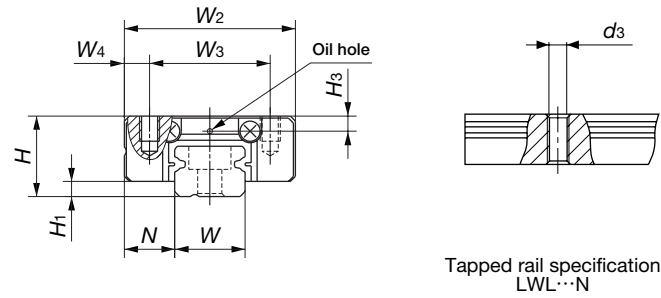

Model number	Interchangeable	Mass(Ref.) g		Dimensions of assembly mm			Dimensions of slide unit mm						
		Slide unit	Track rail (per 100 mm)	H	H <sub>1</sub>	N	W <sub>2</sub>	W <sub>3</sub>	W <sub>4</sub>	L <sub>1</sub>	L <sub>2</sub>	L <sub>3</sub>	M <sub>1</sub> × depth
LWLC 9...B	☆	11	35	10	2	5.5	20	15	2.5	21.5	—	11.9	M3 × 3
LWLC 9...N			37							—	—		
LWL 9...B	☆	19	35	10	2	5.5	20	15	2.5	30	10	20.8	M3 × 3
LWL 9...B CS	☆		37							—	—		
LWLG 9...B	☆	28	35	10	2	5.5	20	15	2.5	40.5	15	30.9	M3 × 3
LWLG 9...N			37							—	—		
LWLC 12...B	☆	22	65	13	3	7.5	27	20	3.5	25	—	13	M3 × 3.5
LWL 12...B	☆	35								34	15	21.6	
LWL 12...B CS	☆	51								44	20	32	
LWLG 12...B	☆	34								34	15	21	

Note(1) : Prepare track rail mounting bolts with a fixing depth less H<sub>4</sub>.  
 (2) : Track rail lengths are shown in Table 10.1 on page B-12 and Table 10.3 on page B-14.  
 (3) : The directions of basic dynamic load rating (C), basic static load rating (C<sub>0</sub>) and static moment rating (T<sub>0</sub>, T<sub>x</sub>, T<sub>y</sub>) are shown in the sketches below. The upper values in the T<sub>x</sub> and T<sub>y</sub> columns apply to one slide unit, and the lower values apply to two slide units in close contact.  
 Remark 1 : The mark ☆ indicates that interchangeable specification products are available.  
 2 : The appended bolts for mounting track rails are hexagon socket head bolts of JIS B 1176 or equivalent. For stainless steel type Linear Way L, stainless steel bolts are appended.  
 3 : The ball non-retained type models (LWL9, LWL12, LWL12...CS) are not provided with an oil hole or grease nipple.  
 4 : An oil hole is provided for size 9 and 12 models of ball retained type and tapped rail specification products.  
 5 : The specification of oil hole is shown on page 101.

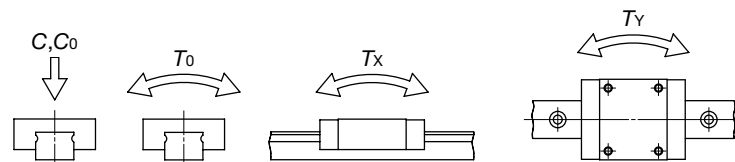

H <sub>3</sub>	Dimensions of track rail mm							Mounting bolt for track rail mm Bolt size × length	Basic dynamic load rating <sup>(3)</sup> C N	Basic static load rating <sup>(3)</sup> C <sub>0</sub> N	Static moment rating <sup>(3)</sup>			
	W	H <sub>4</sub>	d <sub>3</sub>	d <sub>4</sub>	h	E	F				T <sub>0</sub> N·m	T <sub>x</sub> N·m	T <sub>y</sub> N·m	
2.2	9	6	3.5	6	3.5	10	20	M3 × 8	1 180	1 480	6.9	2.9	21.4	2.4
			M4 Through	—	—			M4 × ℓ <sup>(1)</sup> (Not appended)						
			3.5	6	3.5			M3 × 8	1 810	2 760	12.8	9.1	51.1	7.6
			M4 Through	—	—			M4 × ℓ <sup>(1)</sup> (Not appended)						
			3.5	6	3.5			M3 × 8	2 370	4 030	18.7	18.7	98.3	15.7
			M4 Through	—	—			M4 × ℓ <sup>(1)</sup> (Not appended)						
2.7	12	8	3.5	6.5	4.5	12.5	25	M3 × 8	2 210	2 380	14.8	5.3	41.7	4.5
			3.5	6.5	4.5			M3 × 8						
			—	8.5	3.5			6.5	4.5	M3 × 10	4 310	6 200	38.4	30.6

Example of identification number of assembled set (For details, see "Identification number and specification".)

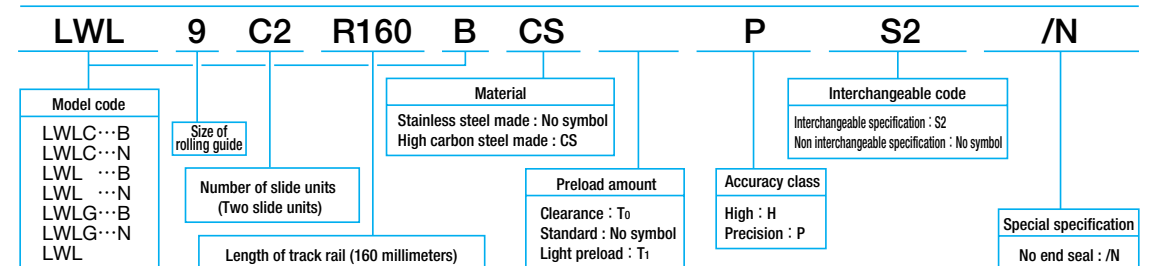

# IKO Linear Way L : Standard type

- Ball retained type**  
 LWLC...B  
 LWL ...B  
 LWL ...B CS (High carbon steel made)  
 LWLG...B
- Ball non-retained type**  
 LWL  
 LWL ...CS (High carbon steel made)

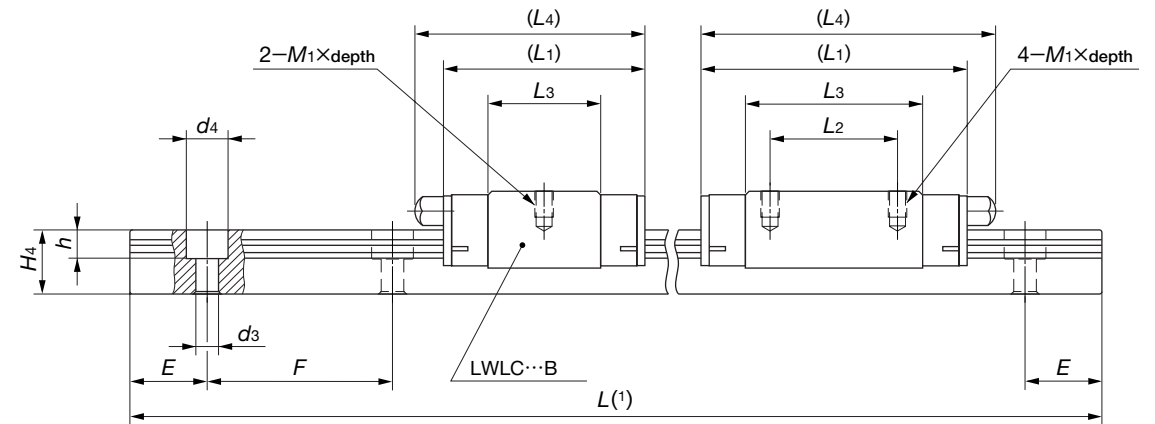
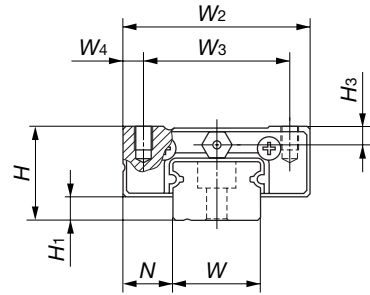

Model number	Interchangeable	Mass (Ref.) g		Dimensions of assembly mm			Dimensions of slide unit mm							
		Slide unit	Track rail (per 100 mm)	H	H <sub>1</sub>	N	W <sub>2</sub>	W <sub>3</sub>	W <sub>4</sub>	L <sub>1</sub>	L <sub>2</sub>	L <sub>3</sub>	L <sub>4</sub>	M <sub>1</sub> × depth
LWLC 15...B	☆	42	107	16	4	8.5	32	25	3.5	32	—	17.7	36	M3×4
LWL 15...B	☆	64								42	20	27.8	47	
LWL 15...B CS	☆	95								57	25	42.7	62	
LWLG 15...B	☆	57								42	20	26.8	—	
LWLC 20...B	☆	89	156	20	5	10	40	30	5	38	—	22.3	42	M4×6
LWL 20...B	☆	133								50	25	34.6	55	
LWL 20...B CS	☆	196								68	30	52.3	72	
LWLG 20...B	☆	190								55	—	31.9	65	
LWLC 25...B	☆	190	243	25	5	12.5	48	35	6.5	55	—	31.9	65	M6×7
LWL 25...B	☆	310								78	35	55.7	89	
LWLG 25...B	☆	413								98	40	75.5	108	

Note<sup>(1)</sup>: Track rail lengths are shown in Table 10.1 on page B-12 and Table 10.3 on page B-14.  
 Note<sup>(2)</sup>: The directions of basic dynamic load rating (C), basic static load rating (C<sub>0</sub>) and static moment rating (T<sub>0</sub>, T<sub>x</sub>, T<sub>y</sub>) are shown in the sketches below. The upper values in the T<sub>x</sub> and T<sub>y</sub> columns apply to one slide unit, and the lower values apply to two slide units in close contact.

- Remark 1: The mark ☆ indicates that interchangeable specification products are available.  
 2: The appended bolts for mounting track rails are hexagon socket head bolts of JIS B 1176 or equivalent. For stainless steel type Linear Way L, stainless steel bolts are appended.  
 3: The ball non-retained type models (LWL15, LWL15...CS) are not provided with an oil hole or grease nipple.  
 4: The specifications of oil hole and grease nipple are shown on page 99.

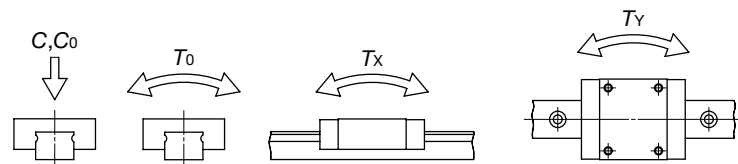

H <sub>3</sub>	Dimensions of track rail mm							Mounting bolt for track rail mm Bolt size × length	Basic dynamic load rating <sup>(?)</sup> C N	Basic static load rating <sup>(?)</sup> C <sub>0</sub> N	Static moment rating <sup>(?)</sup>		
	W	H <sub>4</sub>	d <sub>3</sub>	d <sub>4</sub>	h	E	F				T <sub>0</sub> N·m	T <sub>x</sub> N·m	T <sub>y</sub> N·m
3.1	15	10	3.5	6.5	4.5	20	40	M3×10	3 490	3 890	30.0	11.7 84.5	9.8 70.9
		11							M3×12	4 980	6 490	50.0	29.7 172
—	20	11	6	9.5	5.5	30	60	M5×14	6 620	9 740	75.0	63.9 338	53.6 284
									M3×12	4 760	5 690	47.2	24.6 155
4.2	23	15	7	11.0	9.0	30	60	M6×16	4 580	5 300	54.0	19.4 134	16.3 112
									M5×14	6 650	9 080	92.6	52.7 280
5	23	15	7	11.0	9.0	30	60	M6×16	9 120	10 600	128	57.4 380	48.1 319
									M6×16	13 500	18 500	223	163 887
—	23	15	7	11.0	9.0	30	60	M6×16	16 700	25 200	303	293 1 480	246 1 240
									M6×16	16 700	25 200	303	293 1 480

Example of identification number of assembled set (For details, see "Identification number and specification".)

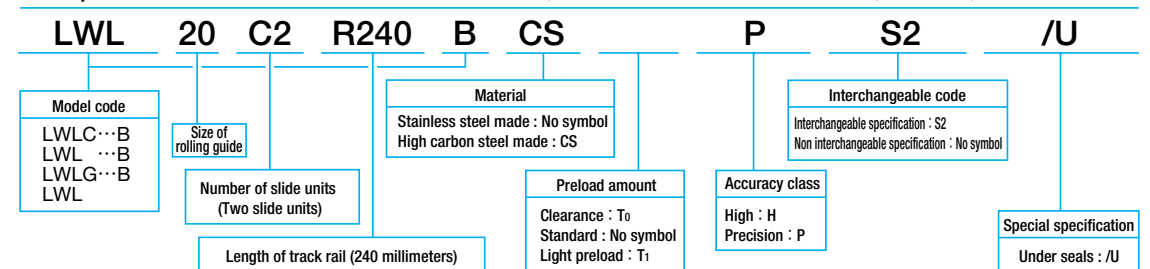

**Ball retained type**  
 LWLFC...B  
 LWLF ...B  
 LWLFG...B  
**Tapped track rail**  
 LWLFC...N  
 LWLF ...N  
 LWLFG...N  
**Ball non-retained type**  
 LWLFC  
 LWLF

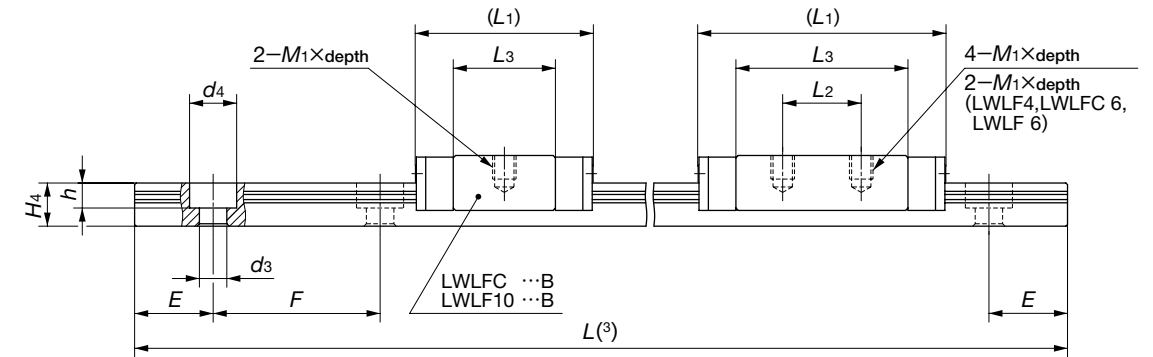
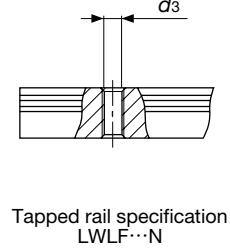
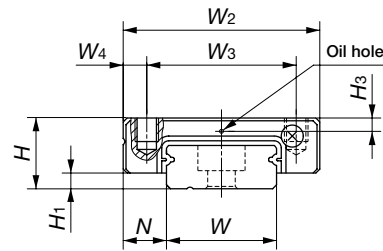

Model number	Interchangeable	Mass (Ref.) g		Dimensions of assembly mm			Dimensions of slide unit mm						
		Slide unit	Track rail (per 100 mm)	H	H <sub>1</sub>	N	W <sub>2</sub>	W <sub>3</sub>	W <sub>4</sub>	L <sub>1</sub>	L <sub>2</sub>	L <sub>3</sub>	M <sub>1</sub> × depth
LWLF 4 <sup>(1)</sup>		2.1	6.8	4	1	3	10	—	5	17	6.5	11.9	M2 × 1.3
LWLFC 6 <sup>(1)</sup>		2.4	13	4.5	1	3	12	—	6	15	4.5	9.8	M2 × 1.6
LWLFC 6...N <sup>(1)</sup>	12												
LWLF 6 <sup>(1)</sup>		3.4	13	20	8	14.6	20	8	14.6	20	8	14.6	M2.5 × 1.5
LWLF 6...N <sup>(1)</sup>	12												
LWLFC 10...B	☆	5.9	28	6.5	1.5	3.5	17	13	2	20.5	—	13.6	M2.5 × 1.5
LWLFC 10...N	29												
LWLF 10...B	☆	7.5	28	24.5	17.6	24.5	17.6	24.5	17.6	24.5	17.6	17.6	M3 × 3
LWLF 10...N	29												
LWLFC 14...B	☆	13	54	9	2	5.5	25	19	3	31.5	10	22	M3 × 3
LWLFC 14...N	56												
LWLF 14...B	☆	21	54	42	19	32.5	42	19	32.5	42	19	32.5	M3 × 3
LWLF 14...N	56												
LWLFG 14...B	☆	31	54	42	19	32.5	42	19	32.5	42	19	32.5	M3 × 3
LWLFG 14...N	56												

Note(1): Size 4 and 6 models are not provided with end seals.  
 (2): Prepare track rail mounting bolts with a fixing depth less H<sub>4</sub>.  
 (3): Track rail lengths are shown in Table 10.2 on page B-13 and Table 10.3 on page B-14.  
 (4): The directions of basic dynamic load rating (C), basic static load rating (C<sub>0</sub>) and static moment rating (T<sub>0</sub>, T<sub>x</sub>, T<sub>y</sub>) are shown in the sketches below. The upper values in the T<sub>x</sub> and T<sub>y</sub> columns apply to one slide unit, and the lower values apply to two slide units in close contact.  
 Remark 1: The mark ☆ indicates that interchangeable specification products are available.  
 2: The appended bolts for mounting track rails are hexagon socket head bolts of JIS B 1176 or equivalent, or cross-recessed head screws for precision equipment.  
 For stainless steel type Linear Way L, stainless steel bolts or screws are appended.  
 3: The mounting bolts M2 or smaller are shown on page B-15. Consult IKO for further information.  
 4: The ball non-retained type models (LWLF4, LWLFC6, LWLF6, LWLF14) are not provided with an oil hole.  
 5: The specification of oil hole is shown on page 101.

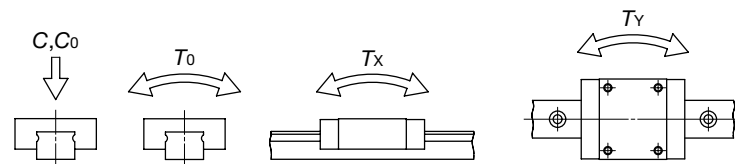

H <sub>3</sub>	Dimensions of track rail mm							Mounting bolt for track rail mm Bolt size × length	Basic dynamic load rating <sup>(4)</sup> C N	Basic static load rating <sup>(4)</sup> C <sub>0</sub> N	Static moment rating <sup>(4)</sup>		
	W	H <sub>4</sub>	d <sub>3</sub>	d <sub>4</sub>	h	E	F				T <sub>0</sub> N·m	T <sub>x</sub> N·m	T <sub>y</sub> N·m
—	4	2.6	1.8	2.8	0.75	5	10	Cross recessed head screw for precision equipment M1.6 × 5	390	677	1.4	1.3 7.1	1.5 8.4
—	6	2.8	2.4	4	1.5	7.5	15	Cross recessed head screw for precision equipment M2 × 4 M3 × ℓ <sup>(2)</sup> (Not appended)	334	542	1.7	0.84 5.1	1.0 6.1
			2.4	4	1.5			Cross recessed head screw for precision equipment M2 × 4 M3 × ℓ <sup>(2)</sup> (Not appended)					
1.3	10	4	2.9	4.8	1.6	10	20	Cross recessed head screw for precision equipment M2.5 × 7 M3 × ℓ <sup>(2)</sup> (Not appended)	712	1 180	6.1	2.6 14.9	2.2 12.5
			2.9	4.8	1.6			Cross recessed head screw for precision equipment M2.5 × 7 M3 × ℓ <sup>(2)</sup> (Not appended)					
			2.9	4.8	1.6			Cross recessed head screw for precision equipment M2.5 × 7 M3 × ℓ <sup>(2)</sup> (Not appended)					
1.7	14	5.5	3.5	6	3.2	15	30	Hexagon socket head bolt M3 × 8 M4 × ℓ <sup>(2)</sup> (Not appended)	1 240	1 700	12.2	3.8 24.6	3.2 20.7
			3.5	6	3.2			Hexagon socket head bolt M3 × 8 M4 × ℓ <sup>(2)</sup> (Not appended)					
			3.5	6	3.2			Hexagon socket head bolt M3 × 8 M4 × ℓ <sup>(2)</sup> (Not appended)					
			3.5	6	3.2			Hexagon socket head bolt M3 × 8 M4 × ℓ <sup>(2)</sup> (Not appended)					

Example of identification number of assembled set (For details, see "Identification number and specification".)

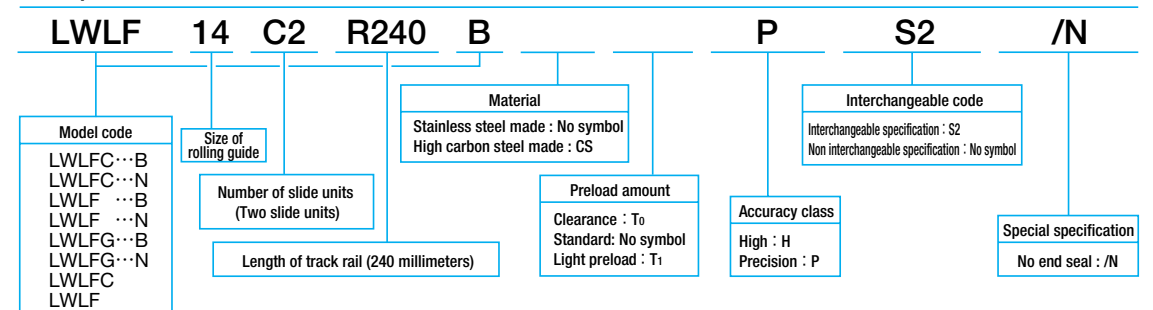

- Ball retained type**  
 LWLFC...B  
 LWLF ...B  
 LWLF ...B CS (High carbon steel made)  
 LWLFG...B
- Tapped track rail**  
 LWLFC...N  
 LWLF ...N  
 LWLFG...N
- Ball non-retained type**  
 LWLF  
 LWLF ...CS (High carbon steel made)

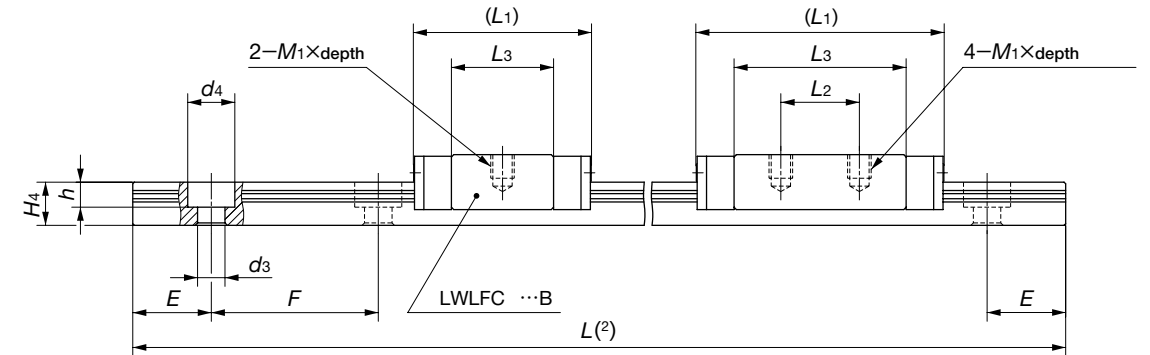
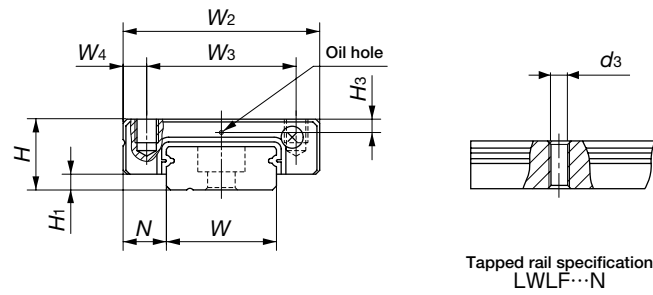

Model number	Interchangeable	Mass (Ref.) g		Dimensions of assembly mm			Dimensions of slide unit mm																
		Slide unit	Track rail (per 100 mm)	H	H <sub>1</sub>	N	W <sub>2</sub>	W <sub>3</sub>	W <sub>4</sub>	L <sub>1</sub>	L <sub>2</sub>	L <sub>3</sub>	M <sub>1</sub> × depth										
LWLFC 18...B	☆	26	90	12	3	6	30	21	4.5	39	12	28.6	M3 × 3										
LWLFC 18...N			92											26.5	—	16.6							
LWLF 18...B	☆	44	90																				
LWLF 18...BCS	☆		92																				
LWLF 18...N		92																					
LWLFG 18...B	☆	61	90											23	3.5	50.5	24	40.4					
LWLFG 18...N			92																				
LWLF 18...CS		39	98											21	4.5	39	12	27.6	M3 × 3				
LWLFC 24...B	☆	45	139											14	3	8	40	28	6	44	15	31	M3 × 3.5
LWLF 24...B	☆	76																					
LWLF 24...BCS	☆	111		44	15	31																	
LWLFG 24...B	☆	111		59	28	46.3																	
LWLF 24...CS		74		44	15	31	M3 × 3																

Note(1) : Prepare track rail mounting bolts with a fixing depth less H<sub>4</sub>.  
 (2) : Track rail lengths are shown in Table 10.2 on page B-13 and Table 10.3 on page B-14.  
 (3) : The directions of basic dynamic load rating (C), basic static load rating (C<sub>0</sub>) and static moment rating (T<sub>0</sub>, T<sub>x</sub>, T<sub>y</sub>) are shown in the sketches below. The upper values in the T<sub>x</sub> and T<sub>y</sub> columns apply to one slide unit, and the lower values apply to two slide units in close contact.  
 Remark 1 : The mark ☆ indicates that interchangeable specification products are available.  
 2 : The appended bolts for mounting track rails are hexagon socket head bolts of JIS B 1176 or equivalent.  
 For stainless steel type Linear Way L, stainless steel bolts are appended.  
 3 : The ball non-retained type models (LWLF18, LWLF18...CS, LWLF24, LWLF24...CS) are not provided with an oil hole or grease nipple.  
 4 : An oil hole is provided for size 18 and 24 models of ball retained type and tapped rail specification products.  
 5 : The specification of oil hole is shown on page 101.

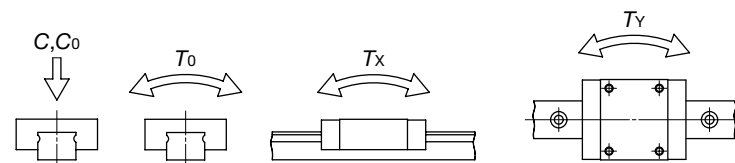

H <sub>3</sub>	Dimensions of track rail mm							Mounting bolt for track rail mm Bolt size × length	Basic dynamic load rating <sup>(3)</sup> C N	Basic static load rating <sup>(3)</sup> C <sub>0</sub> N	Static moment rating <sup>(3)</sup>		
	W	H <sub>4</sub>	d <sub>3</sub>	d <sub>4</sub>	h	E	F				T <sub>0</sub> N·m	T <sub>x</sub> N·m	T <sub>y</sub> N·m
2.5	18	7	3.5	6.5	4.5	15	30	M3 × 8	1 510	2 120	19.4	5.5	4.7
			M4 Through	—	—			M4 × ℓ <sup>(1)</sup> (Not appended)					
			3.5	6.5	4.5			M3 × 8	2 280	3 810	34.9	16.9	14.2
			M4 Through	—	—			M4 × ℓ <sup>(1)</sup> (Not appended)					
			3.5	6.5	4.5			M3 × 8	2 870	5 300	48.5	31.9	26.7
			M4 Through	—	—			M4 × ℓ <sup>(1)</sup> (Not appended)					
—	—	7.5	3.5	6.5	4.5	—	—	2 620	3 950	37.5	17.5	20.9	
3.2	24	8	4.5	8	4.5	20	40	M4 × 10	2 800	3 340	40.7	9.7	8.2
			—	—	—				4 310	6 200	75.6	30.6	25.7
			—	—	—				5 620	9 060	111	63.3	53.1
—	—	8.5	—	—	—	—	—	3 790	5 290	66.7	25.6	30.5	
—	—	—	—	—	—	—	—	—	—	—	145	172	

Example of identification number of assembled set (For details, see "Identification number and specification".)

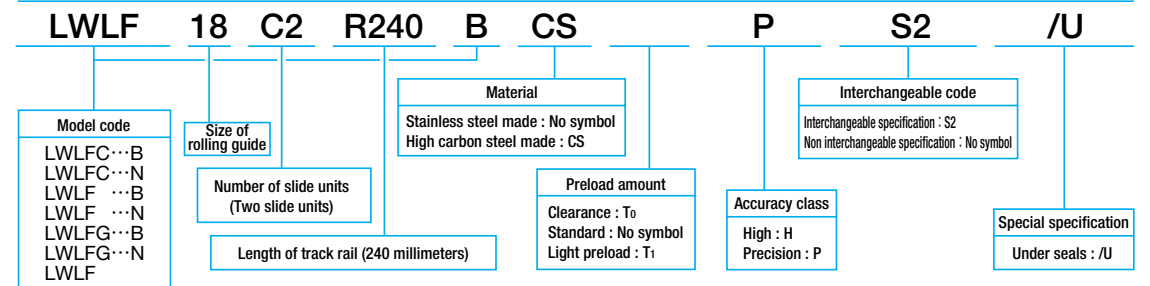



**Ball retained type**  
**LWLFC...B**  
**LWLF ...B**  
**LWLF ...B CS** (High carbon steel made)  
**LWLFG...B**

**Ball non-retained type**  
**LWLF**  
**LWLF ...CS** (High carbon steel made)

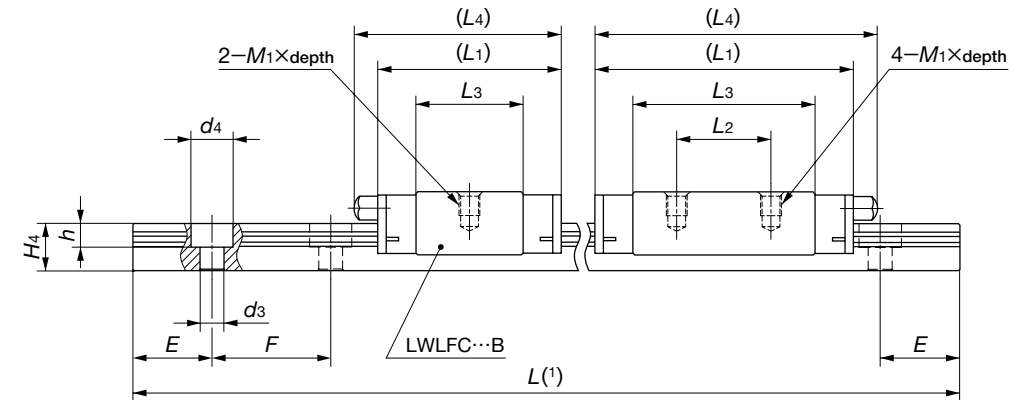
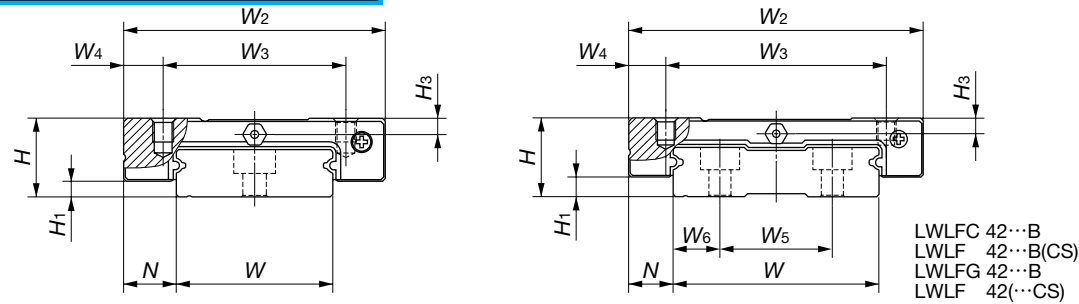

Model number	Interchangeable	Mass (Ref.) g		Dimensions of assembly mm			Dimensions of slide unit mm							
		Slide unit	Track rail (per 100 mm)	H	H <sub>1</sub>	N	W <sub>2</sub>	W <sub>3</sub>	W <sub>4</sub>	L <sub>1</sub>	L <sub>2</sub>	L <sub>3</sub>	L <sub>4</sub>	M <sub>1</sub> ×depth
LWLFC 30...B	☆	70	198	15	3	10	50	35	7.5	35.5	—	20.5	40	M4×4.5
LWLF 30...B	☆	112								50	18	34.8	54	
LWLF 30...B CS	☆	170								68.5	35	53.8	73	
LWLFG 30...B	☆	170								68.5	35	53.8	73	
LWLFC 42...B	☆	95	294	16	4	9	60	45	7.5	41.5	—	25.3	46	M4×4.5
LWLF 42...B	☆	140								55	20	39	60	
LWLF 42...B CS	☆	204								74.5	35	58.3	79	
LWLFG 42...B	☆	204								74.5	35	58.3	79	
LWLF 42...CS		140	300	3						55	20	39.5	—	

H <sub>3</sub>	Dimensions of track rail mm										Mounting bolt for track rail mm Bolt size × length	Basic dynamic load rating <sup>(2)</sup> C N	Basic static load rating <sup>(2)</sup> C <sub>0</sub> N	Static moment rating <sup>(2)</sup>		
	W	H <sub>4</sub>	W <sub>5</sub>	W <sub>6</sub>	d <sub>3</sub>	d <sub>4</sub>	h	E	F	T <sub>0</sub> N·m				T <sub>x</sub> N·m	T <sub>y</sub> N·m	
3.1	30	9	—	—	4.5	8	4.5	20	40	M4 × 12	3 890	4 540	69.1	15.4	13.0	
														107	89.9	
														48.7	40.8	
3.2	42	10	23	9.5	4.5	8	4.5	20	40	M4 × 12	5 030	6 050	128	100	84.3	
														508	426	
														24.8	20.8	
—	—	—	—	—	—	—	—	—	—	—	7 050	9 840	209	61.3	51.4	
														333	280	
														126	106	
—	—	—	—	—	—	—	—	—	—	—	9 200	14 400	305	52.4	62.4	
														291	347	

Note<sup>(1)</sup>: Track rail lengths are shown in Table 10.2 on page B-13 and Table 10.3 on page B-14.

<sup>(2)</sup>: The directions of basic dynamic load rating (C), basic static load rating (C<sub>0</sub>) and static moment rating (T<sub>0</sub>, T<sub>x</sub>, T<sub>y</sub>) are shown in the sketches below. The upper values in the T<sub>x</sub> and T<sub>y</sub> columns apply to one slide unit, and the lower values apply to two slide units in close contact.

Remark 1: The mark ☆ indicates that interchangeable specification products are available.

2: The appended bolts for mounting track rails are hexagon socket head bolts of JIS B 1176 or equivalent.

For stainless steel type Linear Way L, stainless steel bolts are appended.

3: The ball non-retained type models (LWLF 42, LWLF 42...CS) are not provided with an oil holes or grease nipple.

4: The specifications of oil hole and grease nipple are shown on page 99.

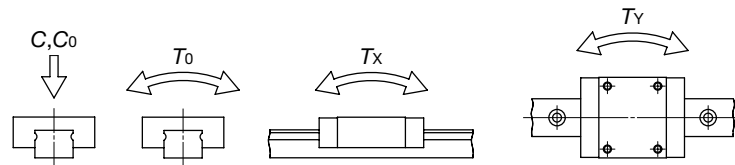

Example of identification number of assembled set (For details, see "Identification number and specification".)

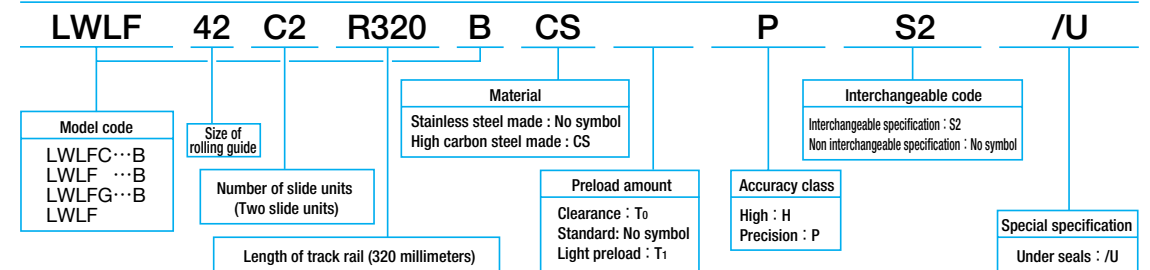

# Linear Way E

LWE/LWET/LWES

**IKO** Linear Way E is a linear motion rolling guide, featuring a compact slide unit which performs endless linear motion along a track rail. Two rows of steel balls are arranged in four point contact with the raceways. This design ensures stable high accuracy and rigidity in operations even under fluctuating loads with changing direction and magnitude or complex loads. A wide range of variations in shapes and sizes are available. This series is a compact type suitable for general applications.

### Interchangeable

Linear Way E includes interchangeable specification products. The dimensions of slide units and track rails of this specification are individually controlled, so that the slide units and track rails can be combined, added or exchanged freely.

### Variable lengths of slide unit

In addition to the standard slide unit, a short type slide unit and a high rigidity long type slide unit both having the same sectional dimensions with the standard slide unit are available.

### Compact design

Lower, narrower, and shorter. Compactness has been pursued in every dimension.

### Flange type and block type

Slide units are available in three different sectional shapes; two flange types for different mounting directions and one block type with a narrow width.

### Stainless steel type

The stainless steel type has excellent corrosion resistance and is most suitable for machines and equipment used in clean environments, for example, medical equipment, semiconductor and FPD manufacturing equipment.

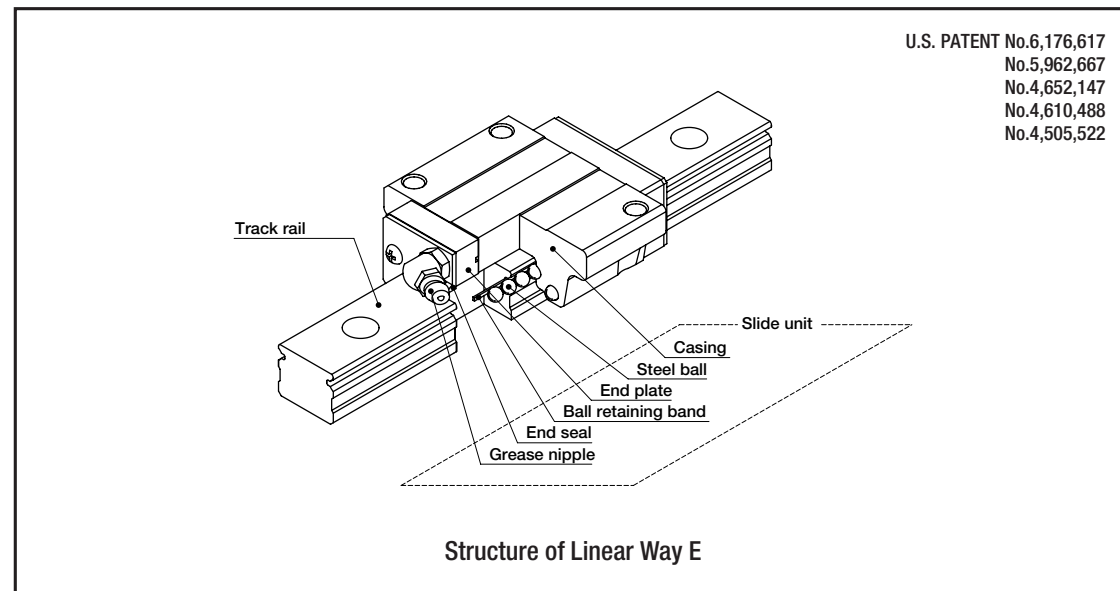

## Linear Way E series

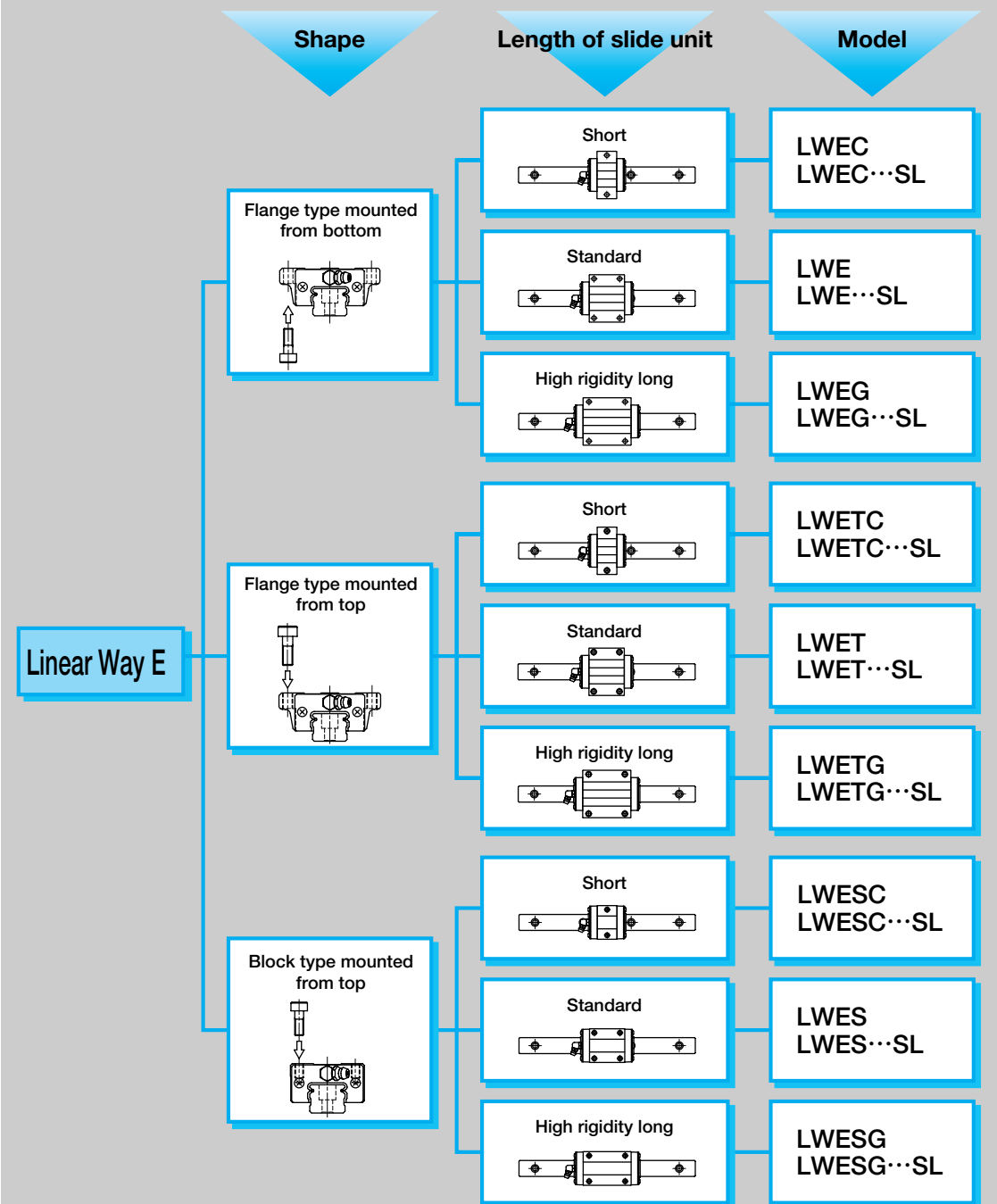

Linear Way E

Remark : Models with "SL" are stainless steel type.

## ● Identification number and specification

The specification of Linear Way E is indicated by the identification number, consisting of a model code, a size, a part code, a material symbol, a preload symbol, a classification symbol, an interchangeable code and any supplemental codes. For details of each specification, see page 78.

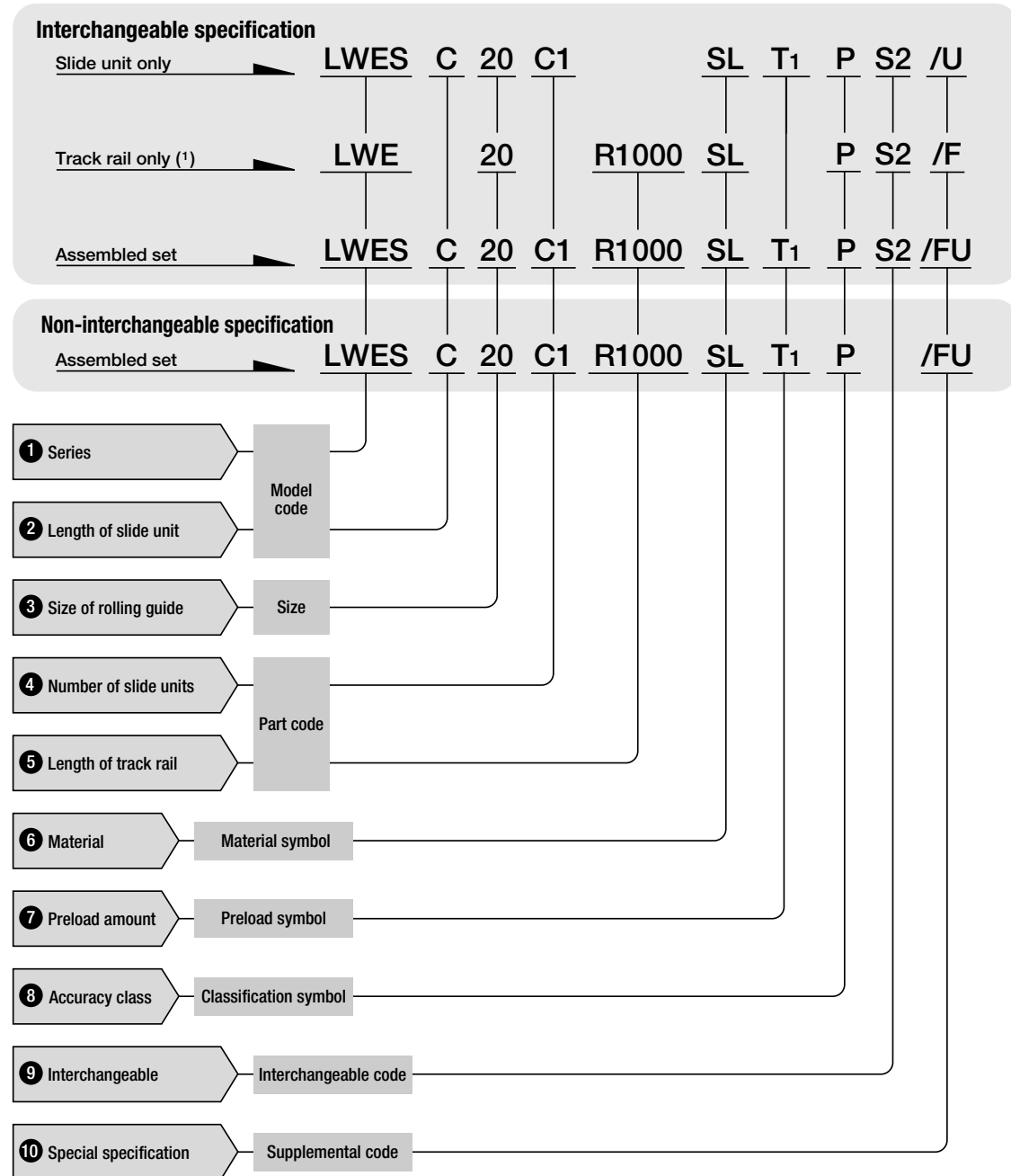

Note(1) : For the model code of a single track rail of interchangeable specification, indicate "LWE" regardless of the slide unit type to be combined.

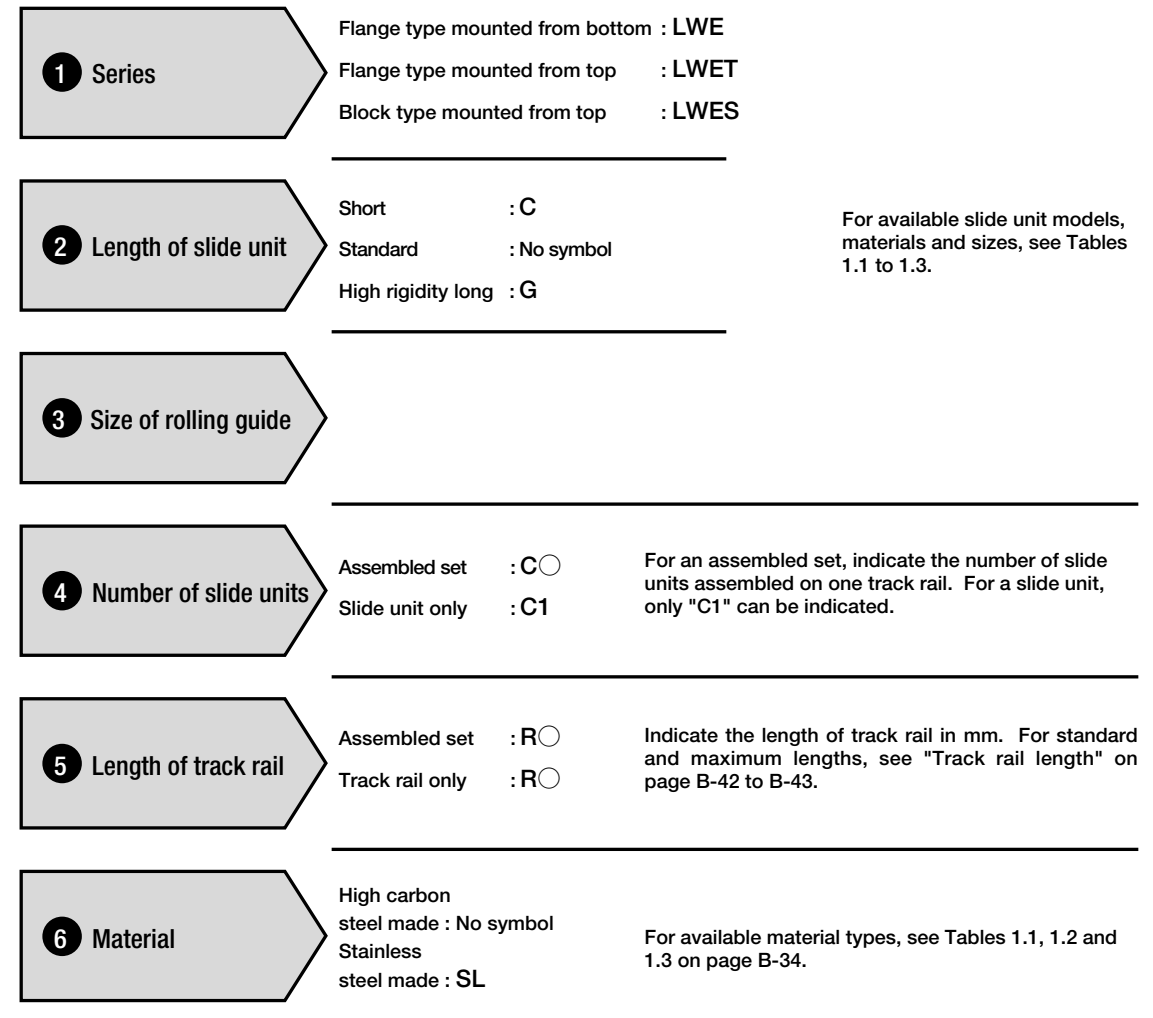

Models and sizes of Linear Way E

Table 1.1 Flange type mounted from bottom

Model Size	High carbon steel made			Stainless steel made		
	Short LWEC	Standard LWE	High rigidity long LWEG	Short LWEC...SL	Standard LWE...SL	High rigidity long LWEG...SL
15	☆	☆	☆	☆	☆	☆
20	☆	☆	☆	☆	☆	☆
25	☆	☆	☆	☆	☆	☆
30	☆	☆	☆	☆	☆	☆
35	☆	☆	—	—	—	—
45	—	☆	—	—	—	—

Table 1.2 Flange type mounted from top

Model Size	High carbon steel made			Stainless steel made		
	Short LWETC	Standard LWET	High rigidity long LWETG	Short LWETC...SL	Standard LWET...SL	High rigidity long LWETG...SL
15	☆	☆	☆	☆	☆	☆
20	☆	☆	☆	☆	☆	☆
25	☆	☆	☆	☆	☆	☆
30	☆	☆	☆	☆	☆	☆
35	☆	☆	—	—	—	—
45	—	☆	—	—	—	—

Table 1.3 Block type mounted from top

Model Size	High carbon steel made			Stainless steel made		
	Short LWESC	Standard LWES	High rigidity long LWESG	Short LWESC...SL	Standard LWES...SL	High rigidity long LWESG...SL
15	☆	☆	☆	☆	☆	☆
20	☆	☆	☆	☆	☆	☆
25	☆	☆	☆	☆	☆	☆
30	☆	☆	☆	☆	☆	☆
35	☆	☆	—	—	—	—
45	—	☆	—	—	—	—

Remark : The mark ☆ indicates that interchangeable specification products are available.

7 Preload amount

Clearance : Tc  
 Standard : No symbol  
 Light preload : T1  
 Medium preload : T2

Specify this item for an assembled set or a single slide unit.  
 For applicable combinations of accuracy and preload amount, see Table 2. For details of preload amount, see page 86.

8 Accuracy class

Ordinary : No symbol  
 High : H  
 Precision : P  
 Super precision : SP

For applicable combinations of accuracy and preload amount, see Table 2. In case of interchangeable specification products, assemble slide units and track rails of the same class. For details of accuracy, see page 81.

Table 2 Accuracy class and preload

Accuracy class (Symbol) Preload (Symbol)	Ordinary (No symbol)	High (H)	Precision (P)	Super precision (SP)
Clearance (Tc)	☆	—	—	—
Standard (No symbol)	☆	☆	☆	○
Light preload (T1)	—	☆	☆	○
Medium preload (T2)	—	○	○	○

Remark : The mark ☆ indicates that interchangeable specification products are available.

9 Interchangeable code

Select group 1 : S1  
 Select group 2 : S2

Specify this item for interchangeable specification products. Assemble track rails and slide units with the same interchangeable code.  
 Performance and accuracy of "S1" group and "S2" group are the same.

10 Special specification

For applicable special specifications, see Table 3. When several special specifications are required, see Table 4. For details of special specifications, see page 88.



Table 5.2 Female threads for bellows for block type slide unit (Supplemental code /J, /JJ)

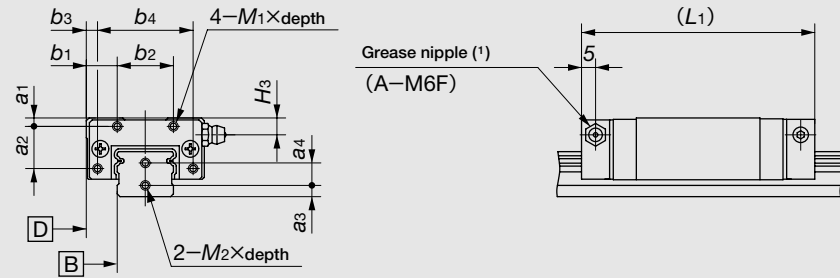

unit : mm

Model number	Slide unit							Track rail				
	a1	a2	b1	b2	b3	b4	M1×depth	L1 <sup>(?)</sup>	H3	a3	a4	M2×depth
LWESC 15	3	12	9	16	3	28	M3×6	58	5.7	4	7	M3× 6
LWES 15								74				
LWESG 15								87				
LWESC 20	3	15	11	20	4	34	M3×6	64	6	4	8	M3× 6
LWES 20								83				
LWESG 20								99				
LWESC 25	3.5	17	11	26	4	40	M3×6	76	7	5	9	M4× 8
LWES 25								100				
LWESG 25								119				
LWESC 30	5	17	13	34	5	50	M3×6	83	11	6	14	M4× 8
LWES 30								112				
LWESG 30								144				
LWESC 35	6	20	15	40	5	60	M3×6	93	13	7	15	M4× 8
LWES 35								126				
LWES 45	7	26	18	50	6	74	M4×8	138	15	8	19	M5×10

Note<sup>(1)</sup> : The specification and mounting position of grease nipple are different from those of the standard specification product.  
Size 15 models are provided with a special specification grease nipple (NPB2 type).  
For details of dimensions, consult **I KO** for further information.

<sup>(?)</sup> : The values for a slide unit with female threads for bellows at both ends are shown.

Remark : The above table shows representative model numbers but is also applicable to stainless steel type models of the same size.

Table 6 Recommended track rail mounting bolt size (Supplemental code /MA)

Model number	Recommended bolt size
LWE 15	M 3×16
	M 4×16 <sup>(1)</sup>
LWE 20	M 5×16
LWE 25	M 6×20
LWE 30	M 6×25
LWE 35	M 8×30
LWE 45	M10×35

Note<sup>(1)</sup> : Applicable to the track rail of supplemental code "/M4" of special specification.

Remark 1 : The above table shows representative model numbers but is applicable to all models of the same size.

2 : Hexagon socket head bolts of strength division 12.9 of JIS B 1176 are recommended.

3 : For stainless Linear Way E, stainless steel bolts are appended when specified supplemental code "/MA".

Table 7 Changed size of mounting holes (Supplemental code /M4)

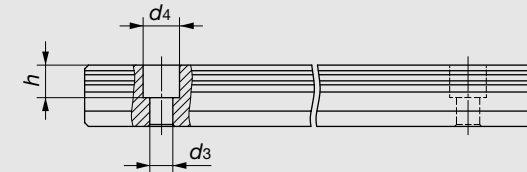

unit : mm

Model number	d3	d4	h
LWE 15	4.5	8	6

Remark : The above table shows a representative model number but is applicable to all models of size 15.

Table 8 Slide unit with Capillary plates (Supplemental code /Q)

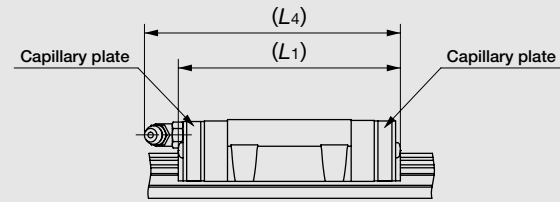

unit : mm

Model number	L <sub>1</sub>	L <sub>4</sub>
<b>LWEC 15</b>	52	55
<b>LWE 15</b>	68	71
<b>LWEG 15</b>	81	83
<b>LWEC 20</b>	58	71
<b>LWE 20</b>	78	91
<b>LWEG 20</b>	94	106
<b>LWEC 25</b>	70	83
<b>LWE 25</b>	94	107
<b>LWEG 25</b>	113	126

Model number	L <sub>1</sub>	L <sub>4</sub>
<b>LWEC 30</b>	80	91
<b>LWE 30</b>	109	119
<b>LWEG 30</b>	141	151
<b>LWEC 35</b>	90	102
<b>LWE 35</b>	123	135
<b>LWE 45</b>	138	148

Remark : The above table shows representative model numbers but is applicable to all models of the same size.

Table 9 H<sub>1</sub> dimension of slide unit with under seals (Supplemental code /U)

unit : mm

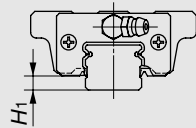

Model number	H <sub>1</sub>
<b>LWE 15</b>	5
<b>LWE 20</b>	5
<b>LWE 25</b>	6
<b>LWE 30</b>	7
<b>LWE 35</b>	8
<b>LWE 45</b>	10

Remark : The above table shows representative model numbers but is applicable to all models of the same size.

Table 10 Slide unit with double end seals (Supplemental code /V, /VV)

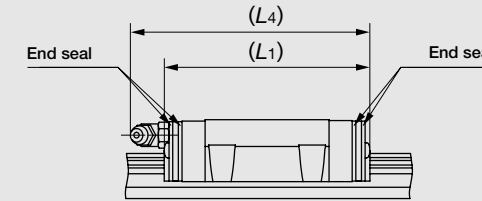

unit : mm

Model number	L <sub>1</sub>	L <sub>4</sub>
<b>LWEC 15</b>	48	50
<b>LWE 15</b>	64	66
<b>LWEG 15</b>	76	78
<b>LWEC 20</b>	54	68
<b>LWE 20</b>	73	87
<b>LWEG 20</b>	89	103
<b>LWEC 25</b>	67	80
<b>LWE 25</b>	91	104
<b>LWEG 25</b>	110	123

Model number	L <sub>1</sub>	L <sub>4</sub>
<b>LWEC 30</b>	78	89
<b>LWE 30</b>	107	118
<b>LWEG 30</b>	138	150
<b>LWEC 35</b>	88	101
<b>LWE 35</b>	121	134
<b>LWE 45</b>	137	148

Remark 1 : The above table shows representative model numbers but is applicable to all models of the same size.  
2 : The values for a slide unit with double end seals at both ends are shown.

Table 11 Slide unit with scrapers (Supplemental code /Z, /ZZ)

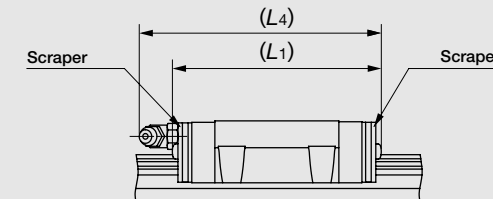

unit : mm

Model number	L <sub>1</sub>	L <sub>4</sub>
<b>LWEC 15</b>	48	50
<b>LWE 15</b>	64	66
<b>LWEG 15</b>	77	79
<b>LWEC 20</b>	55	69
<b>LWE 20</b>	75	88
<b>LWEG 20</b>	90	104
<b>LWEC 25</b>	69	81
<b>LWE 25</b>	93	105
<b>LWEG 25</b>	112	124

Model number	L <sub>1</sub>	L <sub>4</sub>
<b>LWEC 30</b>	79	90
<b>LWE 30</b>	108	119
<b>LWEG 30</b>	140	151
<b>LWEC 35</b>	89	101
<b>LWE 35</b>	122	134
<b>LWE 45</b>	138	148

Remark 1 : The above table shows representative model numbers but is applicable to all models of the same size.  
2 : The values for a slide unit with scrapers at both ends are shown.

## Track rail length

Standard and maximum lengths of track rails are shown in Tables 12.1 and 12.2. Track rails in any length are also available. Simply indicate the necessary length of track rail in mm in the identification number. For the tolerances of *E* dimension and track rail length, consult **IICO** for further information.

- For non-interchangeable track rails longer than the maximum length shown in Tables 12.1 and 12.2, butt-jointing track rails are available upon request. In this case, indicate "/A" in the identification number.
- *E* dimensions at both ends are the same and are within the standard range of *E* unless otherwise specified. To change these dimensions, specify the specified rail mounting hole positions "/E" of special specification. For details, see page 91.

Table 12.1 Standard and maximum lengths of high carbon steel track rails

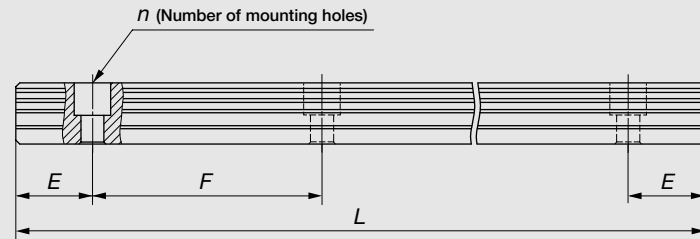

unit : mm

Model number	LWE 15	LWE 20	LWE 25	LWE 30	LWE 35	LWE 45
Standard length <i>L</i> ( <i>n</i> )	160 ( 3) 220 ( 4) 280 ( 5) 340 ( 6) 460 ( 8) 640 (11) 820 (14)	220 ( 4) 280 ( 5) 340 ( 6) 460 ( 8) 640 (11) 820 (14) 1 000 (17) 1 240 (21)	220 ( 4) 280 ( 5) 340 ( 6) 460 ( 8) 640 (11) 820 (14) 1 000 (17) 1 240 (21) 1 600 (27)	280 ( 4) 440 ( 6) 600 ( 8) 760 (10) 1 000 (13) 1 240 (16) 1 640 (21) 2 040 (26) 2 520 (32) 3 000 (38)	280 ( 4) 440 ( 6) 600 ( 8) 760 (10) 1 000 (13) 1 240 (16) 1 640 (21) 2 040 (26) 2 520 (32) 3 000 (38)	570 ( 6) 885 ( 9) 1 200 (12) 1 620 (16) 2 040 (20) 2 460 (24) 2 985 (29)
Pitch of mounting holes <i>F</i>	60	60	60	80	80	105
<i>E</i> (1)	20	20	20	20	20	22.5
Standard range of <i>E</i> (2)	incl.	6	8	9	10	12
	under	36	38	39	49	64.5
Maximum length (3)	1 600 (2 980)	2 200 (2 980)	2 980 (4 000)	3 000 (3 960)	3 000 (3 960)	2 985 (3 930)

Note(1) : When specifying a butt-jointing interchangeable track rail (supplemental code "/T"), pay attention to the *E* dimension at the butt-jointing part.  
 (2) : Not applicable to the track rail with female threads for bellows (supplemental code "/J").  
 (3) : Track rails with the maximum lengths shown in parentheses can also be manufactured. Consult **IICO** for further information.  
 Remark : The above table shows representative model numbers but is applicable to all models of the same size.

Table 12.2 Standard and maximum lengths of stainless steel track rails

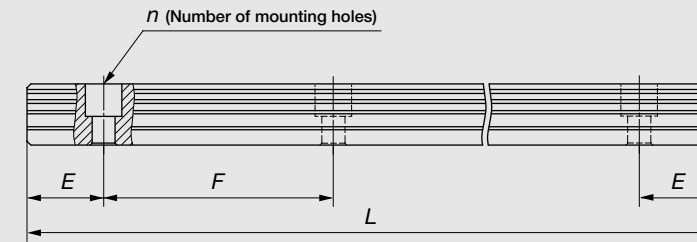

unit : mm

Model number	LWE 15...SL	LWE 20...SL	LWE 25...SL	LWE 30...SL
Standard length <i>L</i> ( <i>n</i> )	160( 3) 220( 4) 280( 5) 340( 6) 460( 8) 640(11) 820(14)	220( 4) 280( 5) 340( 6) 460( 8) 640(11) 820(14) 1 000(17)	220( 4) 280( 5) 340( 6) 460( 8) 640(11) 820(14) 1 000(17)	280( 4) 440( 6) 600( 8) 760(10) 1 000(13)
Pitch of mounting holes <i>F</i>	60	60	60	80
<i>E</i> (1)	20	20	20	20
Standard range of <i>E</i> (2)	incl.	6	8	9
	under	36	38	39
Maximum length (3)(4)	1 200 (1 600)	1 200 (1 960)	1 200 (1 960)	1 200 (1 960)

Note(1) : When specifying a butt-jointing interchangeable track rail (supplemental code "/T"), pay attention to the *E* dimension at the butt-jointing part.  
 (2) : Not applicable to the track rail with female threads for bellows (supplemental code "/J").  
 (3) : The *E* dimension for the rail with the maximum length is 1/2 of the *F* dimension.  
 (4) : Track rails with the maximum lengths shown in parentheses can also be manufactured. Consult **IICO** for further information.  
 Remark : The above table shows representative model numbers but is applicable to all models of the same size.



Flange type mounted from bottom

- LWEC
- LWE
- LWEG
- LWEC...SL (Stainless steel made)
- LWE ...SL (Stainless steel made)
- LWEG...SL (Stainless steel made)

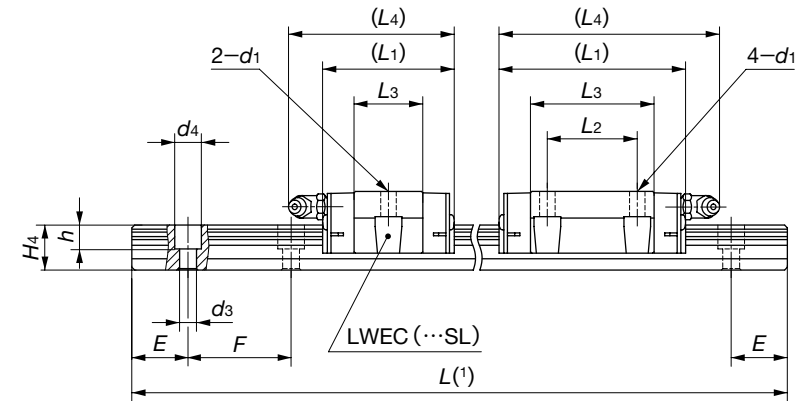
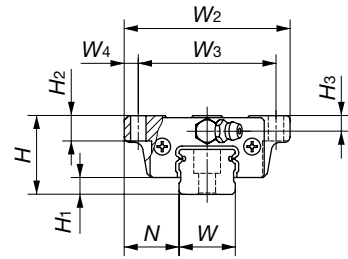

Model number	Interchangeable	Mass (Ref.)		Dimensions of assembly mm			Dimensions of slide unit mm							
		Slide unit kg	Track rail kg/m	H	H <sub>1</sub>	N	W <sub>2</sub>	W <sub>3</sub>	W <sub>4</sub>	L <sub>1</sub>	L <sub>2</sub>	L <sub>3</sub>	L <sub>4</sub>	d <sub>1</sub>
LWEC 15	☆	0.11	1.57	24	5.8	18.5	52	41	5.5	41	—	22.4	45	4.5
LWEC 15...SL	☆									57	26	38.4	61	
LWE 15	☆	0.18	2.28	28	6	19.5	59	49	5	70	36	51.1	74	5.5
LWE 15...SL	☆									66.5	32	44	79	
LWEG 15	☆	0.24	2.28	28	6	19.5	59	49	5	82	45	59.9	95	5.5
LWEG 15...SL	☆									82	45	59.9	95	
LWEC 20	☆	0.18	2.28	28	6	19.5	59	49	5	47	—	24.5	59	5.5
LWEC 20...SL	☆									66.5	32	44	79	
LWE 20	☆	0.30	2.28	28	6	19.5	59	49	5	82	45	59.9	95	5.5
LWE 20...SL	☆									82	45	59.9	95	
LWEG 20	☆	0.40	2.28	28	6	19.5	59	49	5	82	45	59.9	95	5.5
LWEG 20...SL	☆									82	45	59.9	95	

H <sub>2</sub>		H <sub>3</sub>		Dimensions of track rail mm						Basic dynamic load rating <sup>(2)</sup>	Basic static load rating <sup>(2)</sup>	Static moment rating <sup>(2)</sup>		
W	H <sub>4</sub>	d <sub>3</sub>	d <sub>4</sub>	h	E	F	C	C <sub>0</sub>	T <sub>0</sub>	T <sub>x</sub>	T <sub>y</sub>			
									N	N	N·m	N·m	N·m	
7	4.5	15	14.5	3.6	6.5	4.5	20	60	5 240	5 480	43.8	21.3 149	21.3 149	
7	4.5	15	14.5	3.6	6.5	4.5	20	60	7 640	9 390	75.1	57.6 333	57.6 333	
									9 340	12 500	100	99.5 533	99.5 533	
9	5.5	20	16	6	9.5	8.5	20	60	7 570	7 340	78.9	31.5 235	31.5 235	
									11 600	13 400	145	95.6 561	95.6 561	
9	5.5	20	16	6	9.5	8.5	20	60	14 400	18 300	197	172 918	172 918	
									14 400	18 300	197	172 918	172 918	

Note(1) : Track rail lengths are shown in Table 12.1 on page B-42 and Table 12.2 on page B-43.

(2) : The directions of basic dynamic load rating (C), basic static load rating (C<sub>0</sub>) and static moment rating (T<sub>0</sub>, T<sub>x</sub>, T<sub>y</sub>) are shown in the sketches below. The upper values in the T<sub>x</sub> and T<sub>y</sub> columns apply to one slide unit, and the lower values apply to two slide units in close contact.

Remark 1 : The mark ☆ indicates that interchangeable specification products are available.

2 : Track rail mounting bolts are not appended. Hexagon socket bolt of JIS B1176 strength division 12.9 or equivalent are recommended for high carbon steel model. The hexagon socket head bolts of JIS B1176 property division A2-70 or equivalent are recommended for stainless steel models. Recommended bolt sizes are shown in Table 6 on page B-39.

3 : For grease nipple specifications, see page 99.

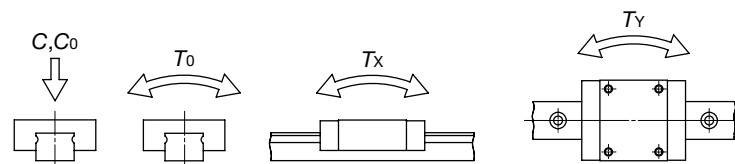

Example of identification number of assembled set (For details, see "Identification number and specification".)

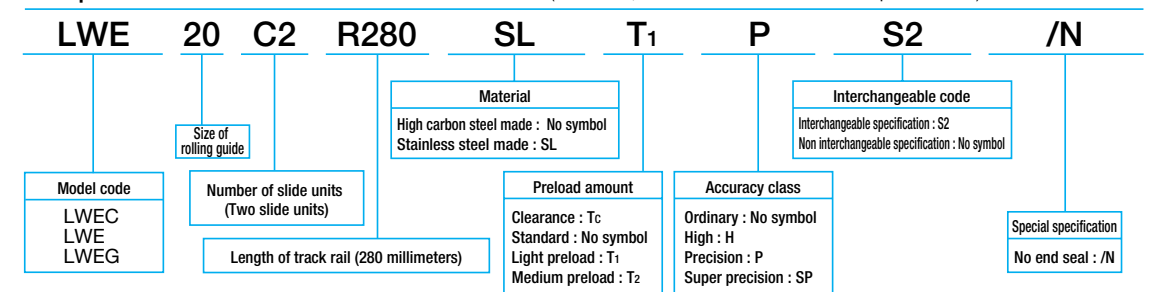

Flange type mounted from bottom  
**LWEC**  
**LWE**  
**LWEG**  
**LWEC...SL** (Stainless steel made)  
**LWE ...SL** (Stainless steel made)  
**LWEG...SL** (Stainless steel made)

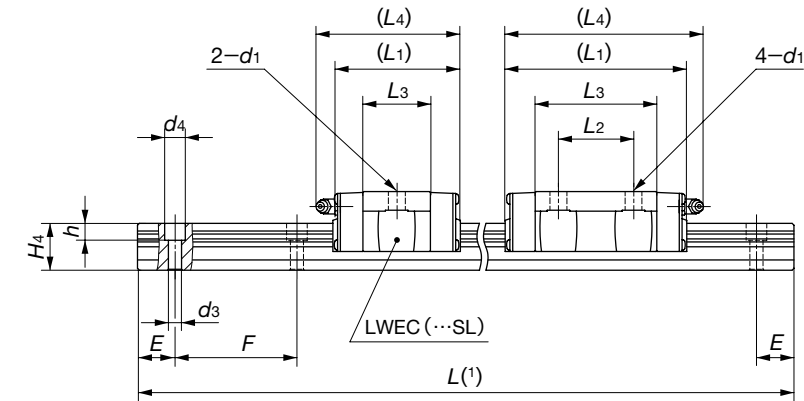
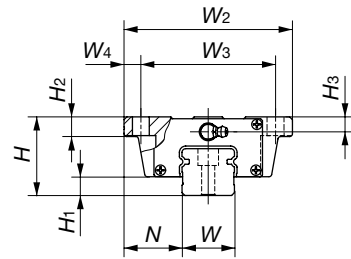

Model number	Interchangeable	Mass (Ref.)		Dimensions of assembly mm			Dimensions of slide unit mm							
		Slide unit kg	Track rail kg/m	H	H <sub>1</sub>	N	W <sub>2</sub>	W <sub>3</sub>	W <sub>4</sub>	L <sub>1</sub>	L <sub>2</sub>	L <sub>3</sub>	L <sub>4</sub>	d <sub>1</sub>
LWEC 25	☆	0.33	3.09	33	7	25	73	60	6.5	59	—	32	71	7
LWEC 25...SL	☆									83	35	56	95	
LWE 25	☆	0.55	3.09	33	7	25	73	60	6.5	83	35	56	95	7
LWE 25...SL	☆									102	50	75	114	
LWEG 25	☆	0.73	3.09	33	7	25	73	60	6.5	102	50	75	114	7
LWEG 25...SL	☆									128.5	60	96.5	139	
LWEC 30	☆	0.58	5.09	42	10	31	90	72	9	68	—	36	78	9
LWEC 30...SL	☆									97	40	64.8	107	
LWE 30	☆	0.99	5.09	42	10	31	90	72	9	97	40	64.8	107	9
LWE 30...SL	☆									128.5	60	96.5	139	
LWEG 30	☆	1.50	5.09	42	10	31	90	72	9	128.5	60	96.5	139	9
LWEG 30...SL	☆									111	50	74.6	123	
LWEC 35	☆	0.84	6.85	48	11	33	100	82	9	78	—	41.6	90	9
LWEC 35...SL	☆									111	50	74.6	123	
LWE 35	☆	1.52	6.85	48	11	33	100	82	9	111	50	74.6	123	9
LWE 35...SL	☆									125	60	81.4	136	
LWE 45	☆	2.46	11.2	60	14	37.5	120	100	10	125	60	81.4	136	11

Note(1) : Track rail lengths are shown in Table 12.1 on page B-42 and Table 12.2 on page B-43.

(2) : The directions of basic dynamic load rating (C), basic static load rating (C<sub>0</sub>) and static moment rating (T<sub>0</sub>, T<sub>x</sub>, T<sub>y</sub>) are shown in the sketches below. The upper values in the T<sub>x</sub> and T<sub>y</sub> columns apply to one slide unit, and the lower values apply to two slide units in close contact.

Remark 1 : The mark ☆ indicates that interchangeable specification products are available.

2 : Track rail mounting bolts are not appended. Hexagon socket bolt of JIS B1176 strength division 12.9 or equivalent are recommended for high carbon steel model. The hexagon socket head bolts of JIS B1176 property division A2-70 or equivalent are recommended for stainless steel models. Recommended bolt sizes are shown in Table 6 on page B-39.

3 : For grease nipple specifications, see page 99.

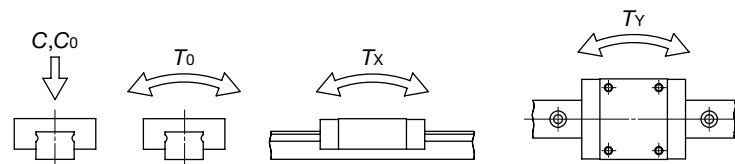

H <sub>2</sub>		H <sub>3</sub>		Dimensions of track rail mm						Basic dynamic load rating <sup>(2)</sup>	Basic static load rating <sup>(2)</sup>	Static moment rating <sup>(2)</sup>			
W	H <sub>4</sub>	d <sub>3</sub>	d <sub>4</sub>	h	E	F	C	C <sub>0</sub>	T <sub>0</sub>	T <sub>x</sub>	T <sub>y</sub>				
											N	N	N·m	N·m	N·m
10	6.5	23	19	7	11	9	20	60	12 400	12 300	153	71.8 480	71.8 480		
10	8	28	25	7	11	9	20	80	18 100	21 100	262	195 1 090	195 1 090		
10	10	34	28	9	14	12	20	80	22 200	28 200	349	336 1 740	336 1 740		
13	10	34	28	9	14	12	20	80	20 600	18 800	287	129 855	129 855		
13	13	45	34	11	17.5	14	22.5	105	29 500	31 300	479	328 1 920	328 1 920		
15	13	45	34	11	17.5	14	22.5	105	39 200	47 000	718	704 3 670	704 3 670		
15	15	55	34	11	17.5	14	22.5	105	29 900	26 800	412	176 1 190	162 1 100		
15	15	55	34	11	17.5	14	22.5	105	42 900	44 700	686	448 2 660	412 2 450		
15	15	55	34	11	17.5	14	22.5	105	61 100	60 200	1 210	672 4 070	618 3 750		

Example of identification number of assembled set (For details, see "Identification number and specification".)

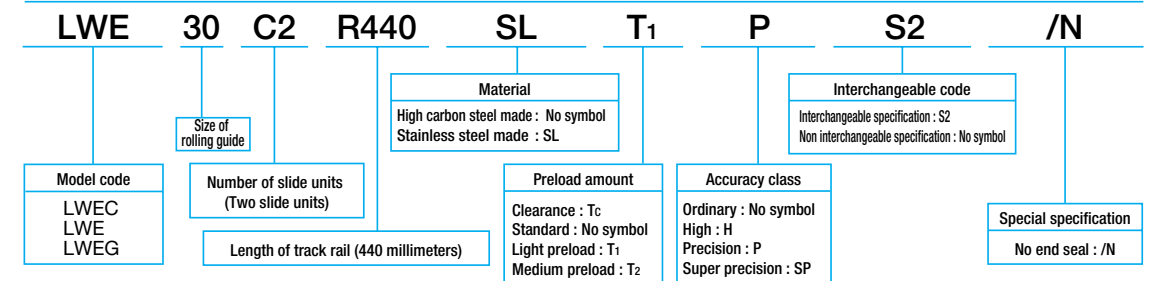

Flange type mounted from top

- LWETC
- LWET
- LWETG
- LWETC...SL (Stainless steel made)
- LWET ...SL (Stainless steel made)
- LWETG...SL (Stainless steel made)

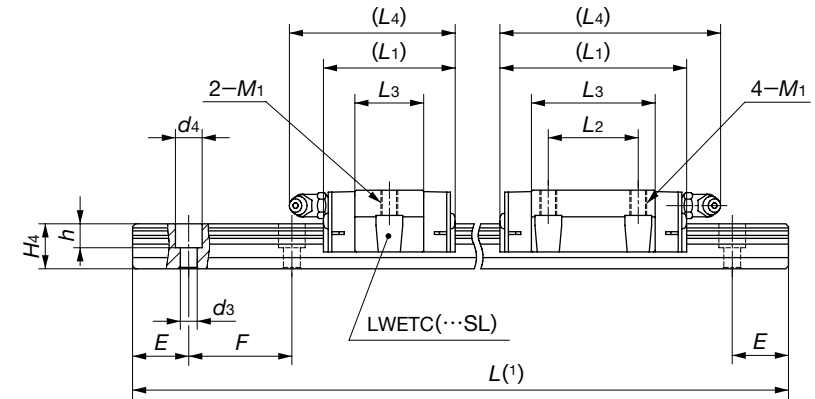
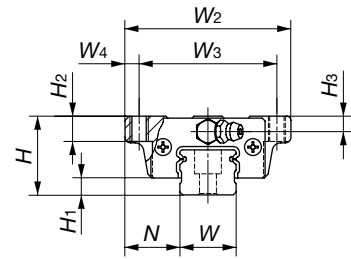

Model number	Interchangeable	Mass (Ref.)		Dimensions of assembly mm			Dimensions of slide unit mm							
		Slide unit kg	Track rail kg/m	H	H1	N	W2	W3	W4	L1	L2	L3	L4	M1
LWETC 15	☆	0.11	1.57	24	5.8	18.5	52	41	5.5	41	—	22.4	45	M 5
LWETC 15...SL	☆									57	26	38.4	61	
LWET 15	☆	0.18	2.28	28	6	19.5	59	49	5	70	36	51.1	74	M 6
LWET 15...SL	☆									66.5	32	44	79	
LWETG 15	☆	0.24	2.28	28	6	19.5	59	49	5	82	45	59.9	95	M 6
LWETG 15...SL	☆									66.5	32	44	79	
LWETC 20	☆	0.18	2.28	28	6	19.5	59	49	5	47	—	24.5	59	M 6
LWETC 20...SL	☆									66.5	32	44	79	
LWET 20	☆	0.30	2.28	28	6	19.5	59	49	5	66.5	32	44	79	M 6
LWET 20...SL	☆									82	45	59.9	95	
LWETG 20	☆	0.40	2.28	28	6	19.5	59	49	5	82	45	59.9	95	M 6
LWETG 20...SL	☆									66.5	32	44	79	

		Dimensions of track rail mm							Basic dynamic load rating <sup>(2)</sup>	Basic static load rating <sup>(2)</sup>	Static moment rating <sup>(2)</sup>			
H2	H3	W	H4	d3	d4	h	E	F	C	C0	T0	Tx	Ty	
										N	N	N·m	N·m	N·m
7	4.5	15	14.5	3.6	6.5	4.5	20	60	5 240	5 480	43.8	21.3	21.3	
									7 640	9 390	75.1	57.6	57.6	
9	5.5	20	16	6	9.5	8.5	20	60	9 340	12 500	100	99.5	99.5	
									7 570	7 340	78.9	31.5	31.5	
									11 600	13 400	145	95.6	95.6	
									14 400	18 300	197	172	172	

Note(1) : Track rail lengths are shown in Table 12.1 on page B-42 and Table 12.2 on page B-43.

(2) : The directions of basic dynamic load rating (C), basic static load rating (C0) and static moment rating (T0, Tx, Ty) are shown in the sketches below. The upper values in the Tx and Ty columns apply to one slide unit, and the lower values apply to two slide units in close contact.

Remark 1 : The mark ☆ indicates that interchangeable specification products are available.

2 : Track rail mounting bolts are not appended. Hexagon socket bolt of JIS B1176 strength division 12.9 or equivalent are recommended for high carbon steel model. The hexagon socket head bolts of JIS B1176 property division A2-70 or equivalent are recommended for stainless steel models. Recommended bolt sizes are shown in Table 6 on page B-39.

3 : For grease nipple specifications, see page 99.

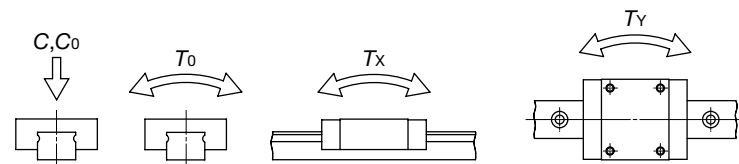

Example of identification number of assembled set (For details, see "Identification number and specification".)

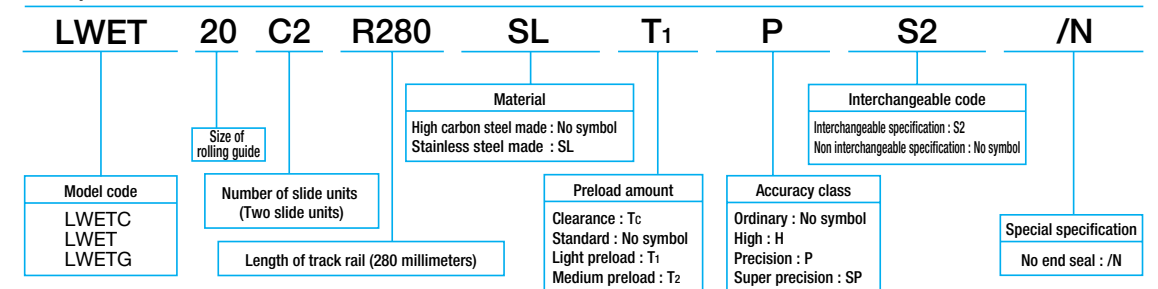

Flange type mounted from top

- LWETC
- LWET
- LWETG
- LWETC ...SL (Stainless steel made)
- LWET ...SL (Stainless steel made)
- LWETG ...SL (Stainless steel made)

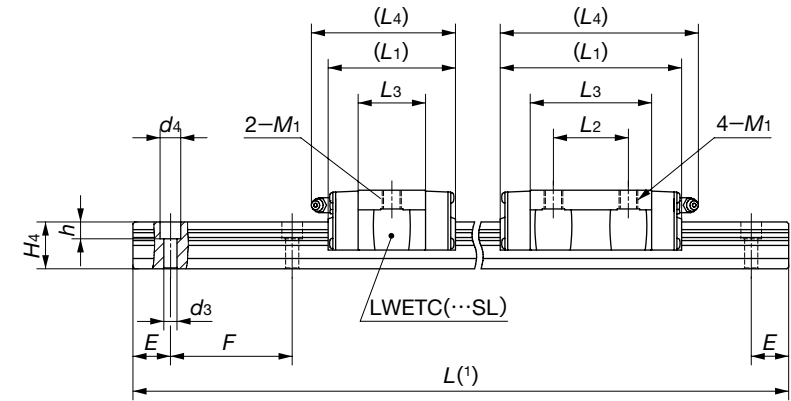
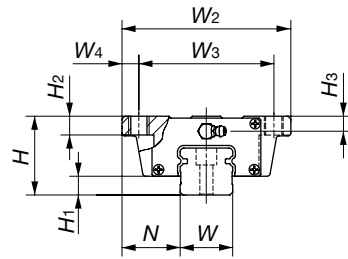

Model number	Interchangeable	Mass (Ref.)		Dimensions of assembly mm			Dimensions of slide unit mm							
		Slide unit kg	Track rail kg/m	H	H1	N	W2	W3	W4	L1	L2	L3	L4	M1
LWETC 25	☆	0.33	3.09	33	7	25	73	60	6.5	59	—	32	71	M 8
LWETC 25...SL	☆									83	35	56	95	
LWET 25	☆	0.55	3.09	33	7	25	73	60	6.5	102	50	75	114	M 8
LWET 25...SL	☆									83	35	56	95	
LWETG 25	☆	0.73	3.09	33	7	25	73	60	6.5	102	50	75	114	M 8
LWETG 25...SL	☆									83	35	56	95	
LWETC 30	☆	0.58	5.09	42	10	31	90	72	9	68	—	36	78	M 10
LWETC 30...SL	☆									97	40	64.8	107	
LWET 30	☆	0.99	5.09	42	10	31	90	72	9	128.5	60	96.5	139	M 10
LWET 30...SL	☆									97	40	64.8	107	
LWETG 30	☆	1.50	5.09	42	10	31	90	72	9	128.5	60	96.5	139	M 10
LWETG 30...SL	☆									97	40	64.8	107	
LWETC 35	☆	0.84	6.85	48	11	33	100	82	9	78	—	41.6	90	M 10
LWET 35	☆									111	50	74.6	123	
LWET 45	☆	2.46	11.2	60	14	37.5	120	100	10	125	60	81.4	136	M 12

Note(1) : Track rail lengths are shown in Table 12.1 on page B-42 and Table 12.2 on page B-43.

(2) : The directions of basic dynamic load rating (C), basic static load rating (Co) and static moment rating (To, Tx, Ty) are shown in the sketches below. The upper values in the Tx and Ty columns apply to one slide unit, and the lower values apply to two slide units in close contact.

Remark 1 : The mark ☆ indicates that interchangeable specification products are available.

2 : Track rail mounting bolts are not appended. Hexagon socket bolt of JIS B1176 strength division 12.9 or equivalent are recommended for high carbon steel model. The hexagon socket head bolts of JIS B1176 property division A2-70 or equivalent are recommended for stainless steel models. Recommended bolt sizes are shown in Table 6 on page B-39.

3 : For grease nipple specifications, see page 99.

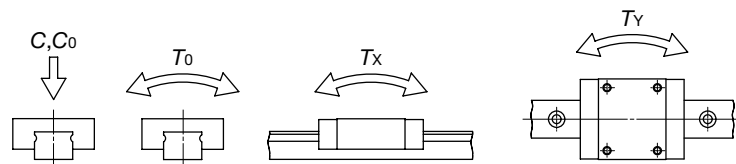

		Dimensions of track rail mm							Basic dynamic load rating <sup>(2)</sup>	Basic static load rating <sup>(2)</sup>	Static moment rating <sup>(2)</sup>			
H2	H3	W	H4	d3	d4	h	E	F	C	Co	To	Tx	Ty	
										N	N	N·m	N·m	N·m
10	6.5	23	19	7	11	9	20	60	12 400	12 300	153	71.8 480	71.8 480	
10	8	28	25	7	11	9	20	80	18 100	21 100	262	195 1 090	195 1 090	
10	10	34	28	9	14	12	20	80	22 200	28 200	349	336 1 740	336 1 740	
13	10	34	28	9	14	12	20	80	20 600	18 800	287	129 855	129 855	
13	13	45	34	11	17.5	14	22.5	105	29 500	31 300	479	328 1 920	328 1 920	
15	13	45	34	11	17.5	14	22.5	105	39 200	47 000	718	704 3 670	704 3 670	
15	15	55	34	13	20	16	25	125	29 900	26 800	412	176 1 190	162 1 110	
15	15	55	34	13	20	16	25	125	42 900	44 700	686	448 2 660	412 2 450	
15	15	55	34	13	20	16	25	125	61 100	60 200	1 210	672 4 070	618 3 750	

Example of identification number of assembled set (For details, see "Identification number and specification".)

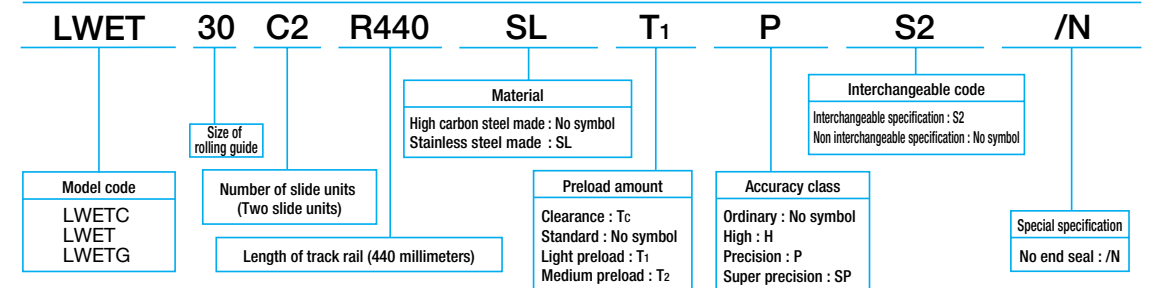

**Block type mounted from top**  
**LWESC**  
**LWES**  
**LWESG**  
**LWESC ...SL** (Stainless steel made)  
**LWES ...SL** (Stainless steel made)  
**LWESG ...SL** (Stainless steel made)

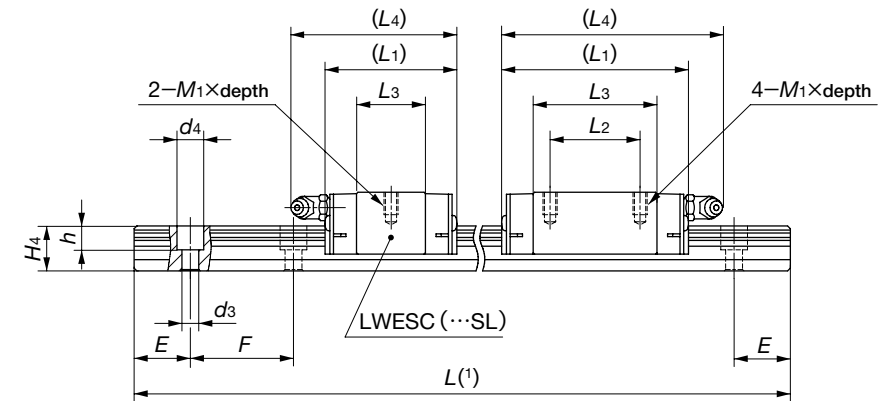
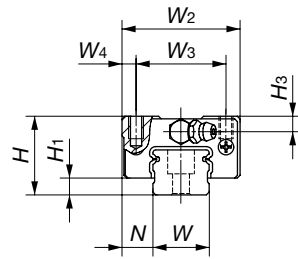

Model number	Interchangeable	Mass (Ref.)		Dimensions of assembly mm			Dimensions of slide unit mm						
		Slide unit kg	Track rail kg/m	H	H <sub>1</sub>	N	W <sub>2</sub>	W <sub>3</sub>	W <sub>4</sub>	L <sub>1</sub>	L <sub>2</sub>	L <sub>3</sub>	L <sub>4</sub>
LWESC 15	☆	0.09	1.57	24	5.8	9.5	34	26	4	41	—	22.4	45
LWESC 15...SL	☆									57	26	38.4	61
LWES 15	☆	0.14	1.57	24	5.8	9.5	34	26	4	70	36	51.1	74
LWES 15...SL	☆									70	36	51.1	74
LWESG 15	☆	0.18	1.57	24	5.8	9.5	34	26	4	70	36	51.1	74
LWESG 15...SL	☆									70	36	51.1	74
LWESC 20	☆	0.15	2.28	28	6	11	42	32	5	47	—	24.5	59
LWESC 20...SL	☆									66.5	32	44	79
LWES 20	☆	0.25	2.28	28	6	11	42	32	5	82	45	59.9	95
LWES 20...SL	☆									82	45	59.9	95
LWESG 20	☆	0.33	2.28	28	6	11	42	32	5	82	45	59.9	95
LWESG 20...SL	☆									82	45	59.9	95

M <sub>1</sub> × depth	H <sub>3</sub>	Dimensions of track rail mm							Basic dynamic load rating <sup>(2)</sup> C N	Basic static load rating <sup>(2)</sup> C <sub>0</sub> N	Static moment rating <sup>(2)</sup>		
		W	H <sub>4</sub>	d <sub>3</sub>	d <sub>4</sub>	h	E	F			T <sub>0</sub> N·m	T <sub>x</sub> N·m	T <sub>y</sub> N·m
M4 × 7	4.5	15	14.5	3.6	6.5	4.5	20	60	5 240	5 480	43.8	21.3 149	21.3 149
									7 640	9 390	75.1	57.6 333	57.6 333
M5 × 8	5.5	20	16	6	9.5	8.5	20	60	7 570	7 340	78.9	31.5 235	31.5 235
									11 600	13 400	145	95.6 561	95.6 561
									14 400	18 300	197	172 918	172 918

Note<sup>(1)</sup> : Track rail lengths are shown in Table 12.1 on page B-42 and Table 12.2 on page B-43.

<sup>(2)</sup> : The directions of basic dynamic load rating (C), basic static load rating (C<sub>0</sub>) and static moment rating (T<sub>0</sub>, T<sub>x</sub>, T<sub>y</sub>) are shown in the sketches below. The upper values in the T<sub>x</sub> and T<sub>y</sub> columns apply to one slide unit, and the lower values apply to two slide units in close contact.

Remark 1 : The mark ☆ indicates that interchangeable specification products are available.

2 : Track rail mounting bolts are not appended. Hexagon socket bolt of JIS B1176 strength division 12.9 or equivalent are recommended for high carbon steel model. The hexagon socket head bolts of JIS B1176 property division A2-70 or equivalent are recommended for stainless steel models. Recommended bolt sizes are shown in Table 6 on page B-39.

3 : For grease nipple specifications, see page 99.

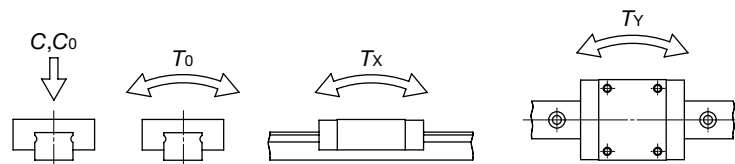

Example of identification number of assembled set (For details, see "Identification number and specification".)

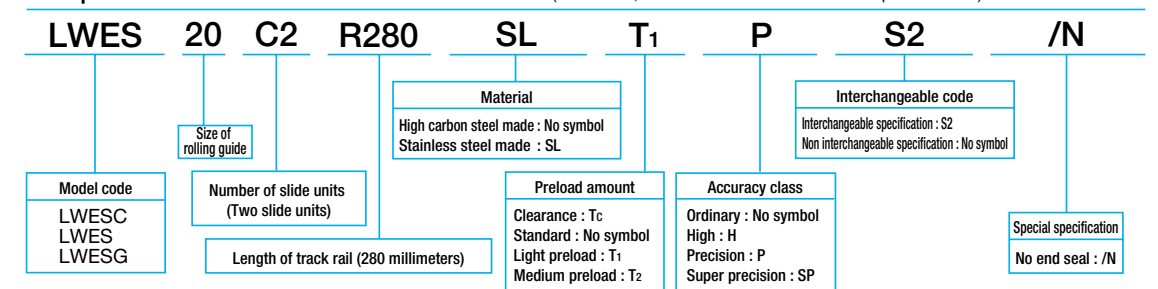

Block type mounted from top  
**LWESC**  
**LWES**  
**LWESG**  
**LWESC ...SL** (Stainless steel made)  
**LWES ...SL** (Stainless steel made)  
**LWESG ...SL** (Stainless steel made)

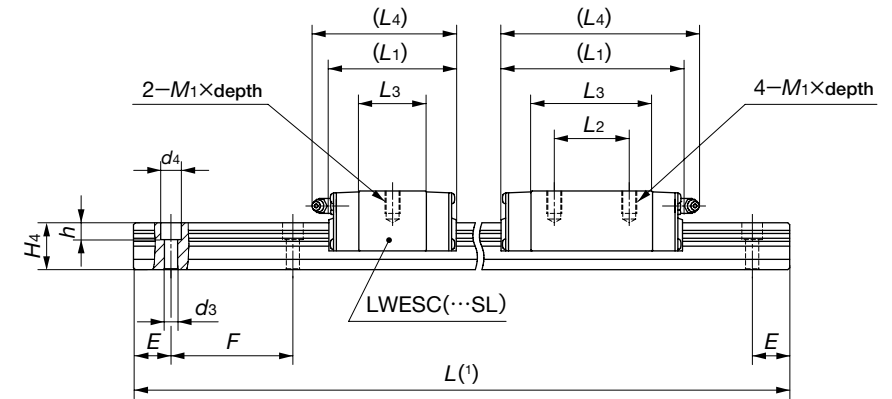
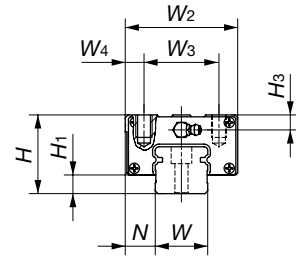

Model number	Interchangeable	Mass (Ref.)		Dimensions of assembly mm			Dimensions of slide unit mm						
		Slide unit kg	Track rail kg/m	H	H <sub>1</sub>	N	W <sub>2</sub>	W <sub>3</sub>	W <sub>4</sub>	L <sub>1</sub>	L <sub>2</sub>	L <sub>3</sub>	L <sub>4</sub>
LWESC 25	☆	0.26	3.09	33	7	12.5	48	35	6.5	59	—	32	71
LWESC 25...SL	☆									83	35	56	95
LWES 25	☆	0.42	3.09	33	7	12.5	48	35	6.5	102	50	75	114
LWES 25...SL	☆									83	35	56	95
LWESG 25	☆	0.55	3.09	33	7	12.5	48	35	6.5	102	50	75	114
LWESG 25...SL	☆									83	35	56	95
LWESC 30	☆	0.46	5.09	42	10	16	60	40	10	68	—	36	78
LWESC 30...SL	☆									97	40	64.8	107
LWES 30	☆	0.78	5.09	42	10	16	60	40	10	128.5	60	96.5	139
LWES 30...SL	☆									97	40	64.8	107
LWESG 30	☆	1.13	5.09	42	10	16	60	40	10	128.5	60	96.5	139
LWESG 30...SL	☆									97	40	64.8	107
LWESC 35	☆	0.67	6.85	48	11	18	70	50	10	78	—	41.6	90
LWES 35	☆									111	50	74.6	123
LWES 45	☆	2.05	11.2	60	14	20.5	86	60	13	125	60	81.4	136

M <sub>1</sub> ×depth	H <sub>3</sub>	Dimensions of track rail mm							Basic dynamic load rating <sup>(2)</sup> C N	Basic static load rating <sup>(2)</sup> C <sub>0</sub> N	Static moment rating <sup>(2)</sup>		
		W	H <sub>4</sub>	d <sub>3</sub>	d <sub>4</sub>	h	E	F			T <sub>0</sub> N·m	T <sub>x</sub> N·m	T <sub>y</sub> N·m
M 6×9	6.5	23	19	7	11	9	20	60	12 400	12 300	153	71.8 480	71.8 480
									18 100	21 100	262	195 1 090	195 1 090
									22 200	28 200	349	336 1 740	336 1 740
M 8×12	8	28	25	7	11	9	20	80	20 600	18 800	287	129 855	129 855
									29 500	31 300	479	328 1 920	328 1 920
									39 200	47 000	718	704 3 670	704 3 670
M 8×12	10	34	28	9	14	12	20	80	29 900	26 800	412	176 1 190	162 1 100
									42 900	44 700	686	448 2 660	412 2 450
M10×15	13	45	34	11	17.5	14	22.5	105	61 100	60 200	1 210	672 4 070	618 3 750

Note(1) : Track rail lengths are shown in Table 12.1 on page B-42 and Table 12.2 on page B-43.

(2) : The directions of basic dynamic load rating (C), basic static load rating (C<sub>0</sub>) and static moment rating (T<sub>0</sub>, T<sub>x</sub>, T<sub>y</sub>) are shown in the sketches below. The upper values in the T<sub>x</sub> and T<sub>y</sub> columns apply to one slide unit, and the lower values apply to two slide units in close contact.

Remark 1 : The mark ☆ indicates that interchangeable specification products are available.

2 : Track rail mounting bolts are not appended. Hexagon socket bolt of JIS B1176 strength division 12.9 or equivalent are recommended for high carbon steel model. The hexagon socket head bolts of JIS B1176 property division A2-70 or equivalent are recommended for stainless steel models. Recommended bolt sizes are shown in Table 6 on page B-39.

3 : For grease nipple specifications, see page 99.

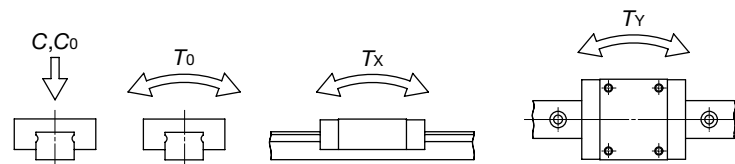

Example of identification number of assembled set (For details, see "Identification number and specification".)

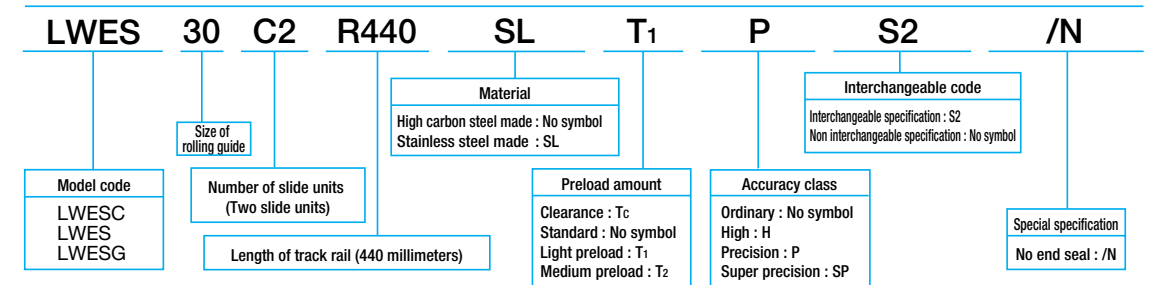

U.S. PATENTED

# Low Decibel Linear Way E

LWE...Q / LWET...Q / LWES...Q

**IKO** Low Decibel Linear Way E is a linear motion rolling guide for smooth and quiet motion. Its low noise characteristic has been achieved by adopting optimum design based on a thorough analysis of ball recirculation behavior and sound quality. Plastic separators are incorporated to eliminate direct contact between balls and thus achieve smooth and quiet motion.

Low Decibel Linear Way E is suitable for production equipment or machinery, in which a large number of linear motion rolling guides are incorporated, and can be used to help reduce the noise level in factory and create a human-friendly environment.

## Low decibel

Plastic separators are incorporated to eliminate direct contact between balls and thus achieve smooth and quiet motion.

## Compact design

Lower, narrower, and shorter. Compactness has been pursued in every dimension.

## Flange type and block type

Slide units are available in three different sectional shapes; two flange types for different mounting directions and one block type with a narrow width.

## Dimensional interchangeability with Linear Way E

The mounting dimensions are the same as those of Linear Way E. So this guide can replace Linear Way E (LWE) with little modifications of machines or equipment.

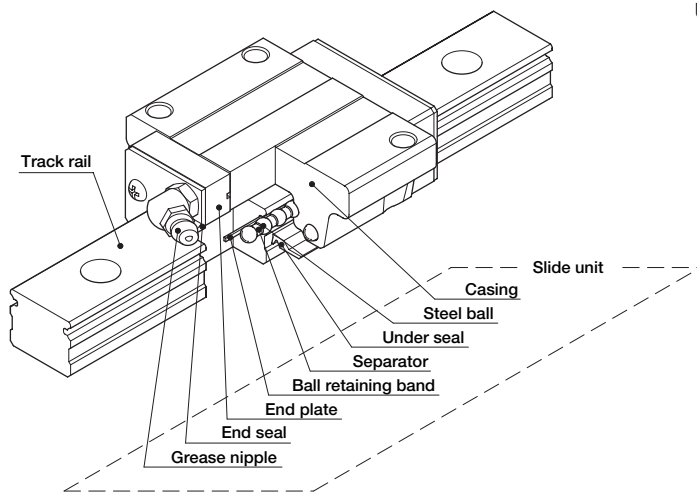

U.S. PATENT No. 6,176,617  
 No. 5,967,667  
 No. 5,564,188  
 No. 5,374,126  
 No. 5,356,223  
 No. 5,324,116  
 No. 4,652,147

Structure of Low Decibel Linear Way E

## Low Decibel Linear Way E series

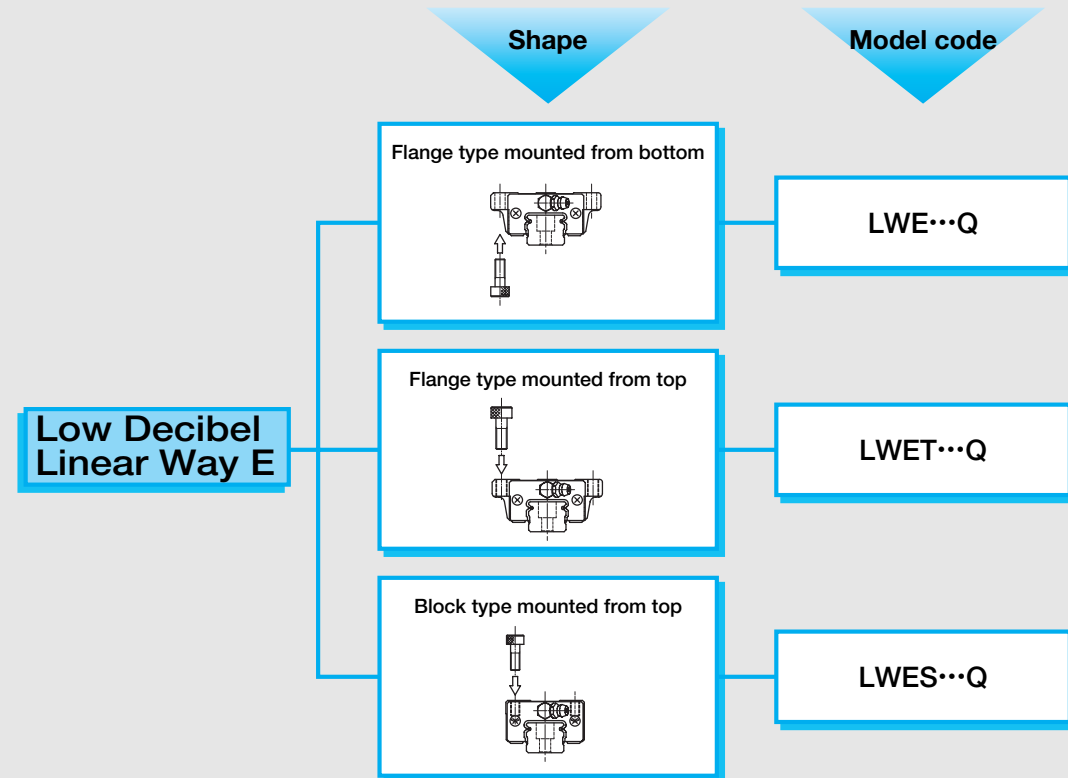

## ● Identification number and specification

The specification of Low Decibel Linear Way E is indicated by the identification number, consisting of a model code, a size, a part code, a preload symbol, a classification symbol and any supplemental codes. For details of each specification, see page 78.

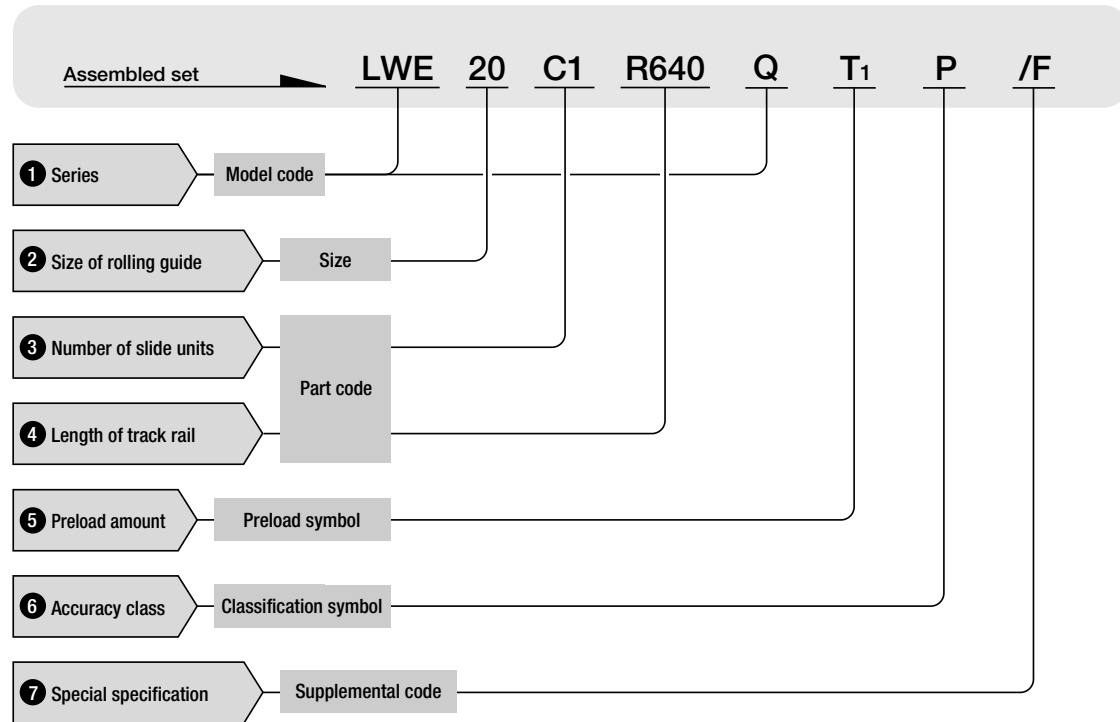

### 1 Series

Flange type mounted from bottom : **LWE** ...**Q**  
 Flange type mounted from top : **LWET**...**Q**  
 Block type mounted from top : **LWES**...**Q**

For available slide unit models and sizes, see Table 1.

### 2 Size of rolling guide

**Table 1 Models and sizes of Low Decibel Linear Way E**

Model / Size	High carbon steel made		
	Flange type mounted from bottom LWE...Q	Flange type mounted from top LWET...Q	Block type mounted from top LWES...Q
15	○	○	○
20	○	○	○
25	○	○	○
30	○	○	○
35	○	○	○

### 3 Number of slide units

: **C**○      Indicate the number of slide units assembled on one track rail.

### 4 Length of track rail

: **R**○      Indicate the length of track rail in mm. For standard and maximum lengths, see "Track rail length" on page B-67.

### 5 Preload amount

Standard : No symbol      For applicable combinations of accuracy and preload amount, see Table 2. For details of preload amount, see page 86.  
 Light preload : **T**1



**6 Accuracy class**

Ordinary : No symbol  
 High : H  
 Precision : P  
 Super precision : SP

For applicable combinations of accuracy and preload amount, see Table 2. For details of accuracy, see page 81.

Table 2 Accuracy class and preload

Accuracy class (Symbol) Preload (Symbol)	Ordinary (No symbol)	High (H)	Precision (P)	Super precision (SP)
Standard (No symbol)	○	○	○	○
Light preload (T1)	—	○	○	○

**7 Special specification**

For applicable special specifications, see Table 3. When several special specifications are required, see Table 4. For details of special specifications, see page 88.

Table 3 Special specifications

Special specification	Supplemental code	Assembled set	Dimension
Opposite reference surfaces arrangement	D	○	
Specified rail mounting hole positions	E	○	
Caps for rail mounting holes	F	○	
Inspection sheet	I	○	
Female threads for bellows	J	○	See Table 5.1, Table 5.2.
Black chrome surface treatment	L	○	
Fluorine black chrome surface treatment	LF	○	
Supplied with track rail mounting bolt	MA	○	See Table 6.
Changed size of mounting holes	M4	○ <sup>(1)</sup>	See Table 7.
Capillary plates	Q	○	See Table 8.
Double end seals	V	○	See Table 9.
Matched sets to be used as an assembled group	W	○	
Specified grease	Y	○	
Scrapers	Z	○	See Table 10.

Note(1) : Applicable to size 15 models.

Table 4 Combination of special specifications

E	—																	
F	○	○																
I	○	○	○															
J	○	○	○	○														
L	○	○	○	○	○													
LF	○	○	○	○	○	○	—											
MA	○	○	○	○	○	○	○	○										
M4	○	○	○	○	○	○	○	○	○									
Q	○	○	○	○	○	○	—	○	○	○								
V	○	○	○	○	○	○	○	○	○	○	○	—						
W	○	—	○	○	○	○	○	○	○	○	○	○	○					
Y	○	○	○	○	○	○	○	○	○	○	○	○	—	○	○			
Z	○	○	○	○	○	○	○	○	○	○	○	○	○	—	○	○	○	
	D	E	F	I	J	L	LF	MA	M4	Q	V	W	Y					

Remark : When several special specifications are required, arrange the supplemental codes alphabetically.

Table 5.1 Female threads for bellows for flange type slide unit (Supplemental code /J, /JJ)

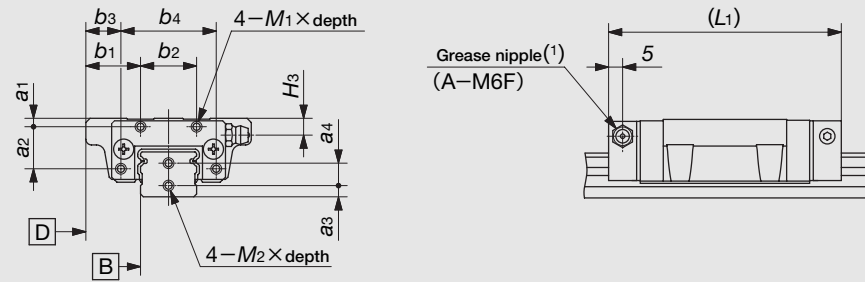

unit : mm

Model number	Slide unit										Track rail		
	a1	a2	b1	b2	b3	b4	M1×depth	L1 <sup>(?)</sup>	H3	a3	a4	M2×depth	
LWE (T) 15...Q	3	12	18	16	12	28	M3×6	74	5.7	4	7	M3×6	
LWE (T) 20...Q	3	15	19.5	20	12.5	34	M3×6	83	6	4	8	M3×6	
LWE (T) 25...Q	3.5	17	23.5	26	16.5	40	M3×6	100	7	5	9	M4×8	
LWE (T) 30...Q	5	20	25	40	20	50	M3×6	111	10	6	14	M4×8	
LWE (T) 35...Q	6	20	30	40	20	60	M3×6	125	11	7	15	M4×8	

Note<sup>(1)</sup> : The specification and mounting position of grease nipple are different from those of the standard specification product.  
 Size 15 models are provided with a special specification grease nipple (NPB2 type). For details of dimensions, consult IICO for further information.  
<sup>(?)</sup> : The values for a slide unit with female threads for bellows at both ends are shown.

Table 5.2 Female threads for bellows for block type slide unit (Supplemental code /J, /JJ)

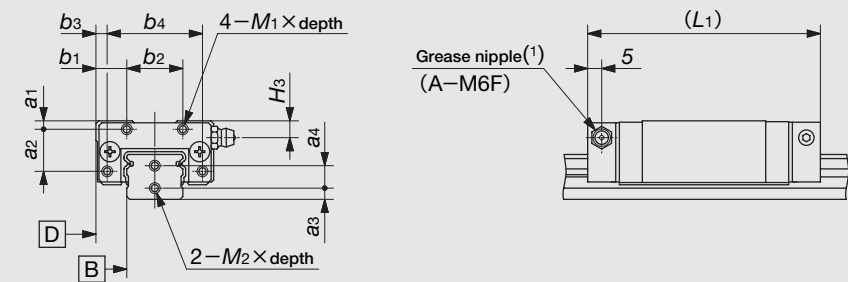

unit : mm

Model number	Slide unit										Track rail		
	a1	a2	b1	b2	b3	b4	M1×depth	L1 <sup>(?)</sup>	H3	a3	a4	M2×depth	
LWES 15...Q	3	12	9	16	3	28	M3×6	74	5.7	4	7	M3×6	
LWES 20...Q	3	15	11	20	4	34	M3×6	83	6	4	8	M3×6	
LWES 25...Q	3.5	17	11	26	4	40	M3×6	100	7	5	9	M4×8	
LWES 30...Q	5	20	10	40	5	50	M3×6	111	10	6	14	M4×8	
LWES 35...Q	6	20	15	40	5	60	M3×6	125	11	7	15	M4×8	

Note<sup>(1)</sup> : The specification and mounting position of grease nipple are different from those of the standard specification product.  
 Size 15 models are provided with a special specification grease nipple (NPB2 type). For details of dimensions, consult IICO for further information.  
<sup>(?)</sup> : The values for a slide unit with female threads for bellows at both ends are shown.

Table 6 Recommended track rail mounting bolt size (Supplemental code /MA)

Model number	Recommended bolt size
LWE 15...Q	M3×16 M4×16(1)
LWE 20...Q	M5×16
LWE 25...Q	M6×20
LWE 30...Q	M6×25
LWE 35...Q	M8×30

Note(1) : Applicable to the track rail of supplemental code "/M4" of special specification.

Remark 1 : The above table shows representative model numbers but is applicable to all models of the same size.  
2 : Hexagon socket head bolts of strength division 12.9 of JIS B 1176 are recommended.

Table 7 Changed size of mounting holes (Supplemental code /M4)

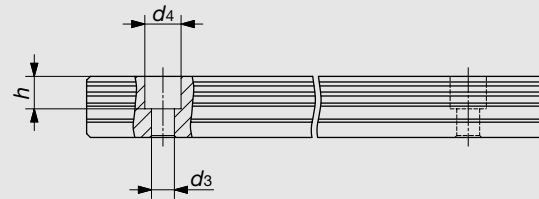

unit : mm

Model number	$d_3$	$d_4$	$h$
LWE 15...Q	4.5	8	6

Remark : The above table shows a representative model number but is applicable to all models of size 15.

Table 8 Slide unit with Capillary plates (Supplemental code /Q)

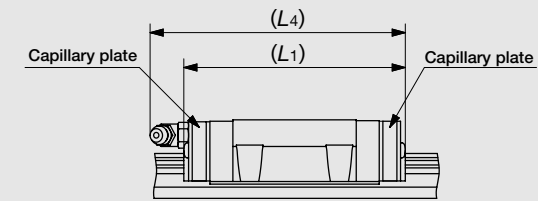

unit : mm

Model number	$L_1$	$L_4$
LWE 15...Q	68	71
LWE 20...Q	78	91
LWE 25...Q	94	107
LWE 30...Q	109	119
LWE 35...Q	124	135

Remark : The above table shows representative model numbers but is applicable to all models of the same size.

Table 9 Slide unit with double end seals (Supplemental code /V, /VV)

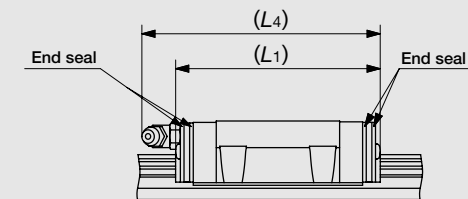

unit : mm

Model number	$L_1$	$L_4$
LWE 15...Q	64	66
LWE 20...Q	73	87
LWE 25...Q	91	104
LWE 30...Q	107	118
LWE 35...Q	121	134

Remark : The above table shows representative model numbers but is applicable to all models of the same size.

Table 10 Slide unit with scrapers (Supplemental code /Z, /ZZ)

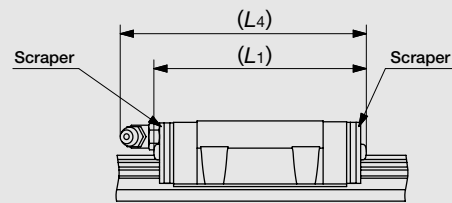

unit : mm

Model number	L1	L4
LWE 15...Q	64	66
LWE 20...Q	75	88
LWE 25...Q	93	105
LWE 30...Q	109	119
LWE 35...Q	123	135

Remark : The above table shows representative model numbers but is applicable to all models of the same size.

## Track rail length

Standard and maximum lengths of track rails are shown in Table 11. When requiring track rails in any other length, consult **IICO** for further information. For the tolerances of *E* dimension and track rail length, consult **IICO** for further information.

- E* dimensions at both ends are the same and are within the standard range of *E* unless otherwise specified. To change these dimensions, specify the specified rail mounting hole positions "/E" of special specification. For details, see page 91.

Table 11 Standard and maximum lengths of track rails

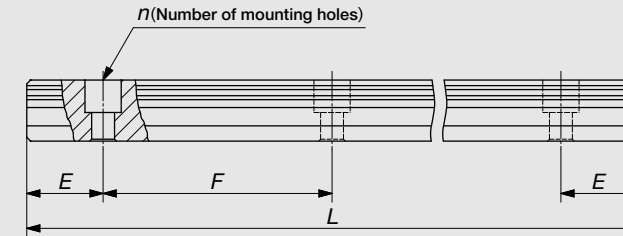

unit : mm

Item \ Model number	LWE 15...Q	LWE 20...Q	LWE 25...Q	LWE 30...Q	LWE 35...Q
Standard length <i>L</i> ( <i>n</i> )	160 ( 3)	220 ( 4)	220 ( 4)	280 ( 4)	280 ( 4)
	220 ( 4)	280 ( 5)	280 ( 5)	440 ( 6)	440 ( 6)
	280 ( 5)	340 ( 6)	340 ( 6)	600 ( 8)	600 ( 8)
	340 ( 6)	460 ( 8)	460 ( 8)	760 (10)	760 (10)
	460 ( 8)	640 (11)	640 (11)	1 000 (13)	1 000 (13)
	640 (11)	820 (14)	820 (14)	1 240 (16)	1 240 (16)
	820 (14)	1 000 (17)	1 000 (17)	1 640 (21)	1 640 (21)
		1 240 (21)	1 240 (21)	2 040 (26)	2 040 (26)
		1 600 (27)	2 520 (32)	2 520 (32)	
			3 000 (38)	3 000 (38)	
Pitch of mounting holes <i>F</i>	60	60	60	80	80
<i>E</i>	20	20	20	20	20
Standard range of <i>E</i> (1)	incl.	6	8	9	10
	under	36	38	39	49
Maximum length	1 600	2 200	2 980	3 000	3 000

Note(1) : Not applicable to the track rail with female threads for bellows (supplemental code "/J").

Remark : The above table shows representative model numbers but is applicable to all models of the same size.

Flange type mounted from bottom  
LWE ...Q

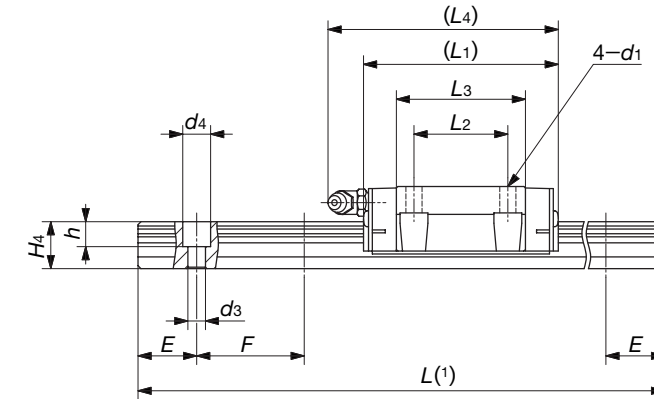
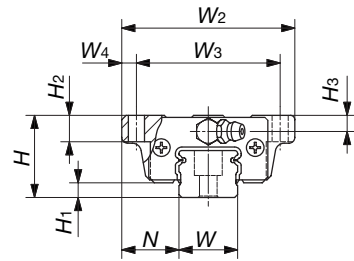

Model number	Mass (Ref.)		Dimensions of assembly mm			Dimensions of slide unit mm							
	Slide unit kg	Track rail kg/m	H	H <sub>1</sub>	N	W <sub>2</sub>	W <sub>3</sub>	W <sub>4</sub>	L <sub>1</sub>	L <sub>2</sub>	L <sub>3</sub>	L <sub>4</sub>	d <sub>1</sub>
LWE 15...Q	0.18	1.57	24	5	18.5	52	41	5.5	57	26	38.4	61	4.5
LWE 20...Q	0.30	2.28	28	5	19.5	59	49	5	66.5	32	44	79	5.5
LWE 25...Q	0.56	3.09	33	6	25	73	60	6.5	83	35	56	95	7
LWE 30...Q	0.97	5.04	42	10	31	90	72	9	95.5	40	64.8	106	9
LWE 35...Q	1.53	6.84	48	11	33	100	82	9	109.5	50	76.6	122	9

Note(1) : Track rail lengths are shown in Table 11 on page B-67.

(2) : The directions of basic dynamic load rating (C), basic static load rating (C<sub>0</sub>) and static moment rating (T<sub>0</sub>, T<sub>x</sub>, T<sub>y</sub>) are shown in the sketches below. The upper values in the T<sub>x</sub> and T<sub>y</sub> columns apply to one slide unit, and the lower values apply to two slide units in close contact.

Remark 1 : Track rail mounting bolts are not appended. Hexagon socket bolt of JIS B1176 strength division 12.9 or equivalent are recommended. Recommended bolt sizes are shown in Table 6 on page B-64.

2 : For grease nipple specifications, see page 99.

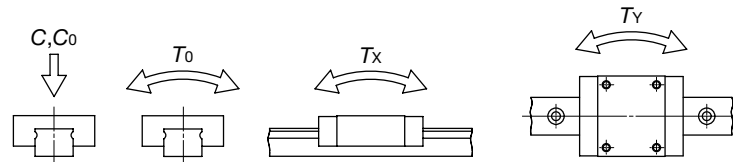

		Dimensions of track rail mm							Basic dynamic load rating <sup>(2)</sup>	Basic static load rating <sup>(2)</sup>	Static moment rating <sup>(2)</sup>		
H <sub>3</sub>	H <sub>5</sub>	W	H <sub>4</sub>	d <sub>3</sub>	d <sub>4</sub>	h	E	F	C N	C <sub>0</sub> N	T <sub>0</sub> N·m	T <sub>x</sub> N·m	T <sub>y</sub> N·m
7	4.5	15	14.5	3.6	6.5	4.5	20	60	6 550	8 610	68.9	53.0 307	53.0 307
9	5.5	20	16	6	9.5	8.5	20	60	10 500	13 400	145	100 557	100 557
10	6.5	23	19	7	11	9	20	60	15 500	19 400	240	175 1 010	175 1 010
10	8	28	25	7	11	9	20	80	21 600	26 400	398	278 1 570	278 1 570
13	10	34	28	9	14	12	20	80	30 500	37 600	687	482 2 530	482 2 530

Example of identification number (For details, see "Identification number and specification".)

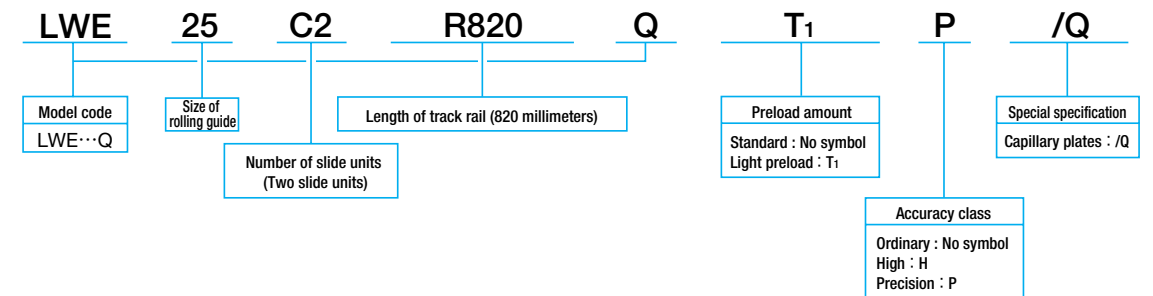

Flange type mounted from top  
LWET ...Q

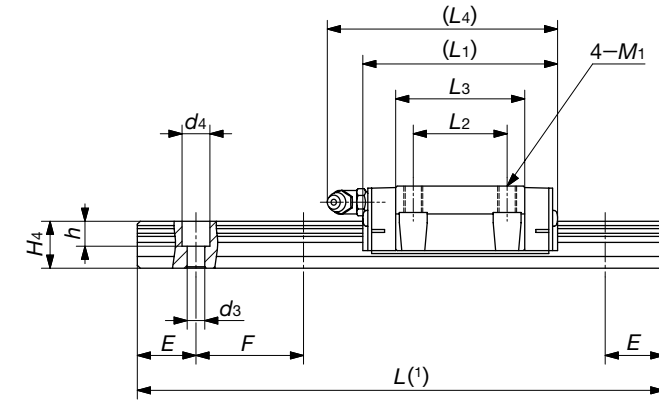
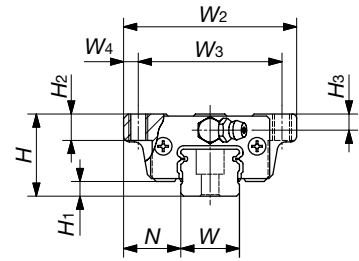

Model number	Mass (Ref.)		Dimensions of assembly mm			Dimensions of slide unit mm							
	Slide unit kg	Track rail kg/m	H	H <sub>1</sub>	N	W <sub>2</sub>	W <sub>3</sub>	W <sub>4</sub>	L <sub>1</sub>	L <sub>2</sub>	L <sub>3</sub>	L <sub>4</sub>	M <sub>1</sub>
LWET 15...Q	0.18	1.57	24	5	18.5	52	41	5.5	57	26	38.4	61	M 5
LWET 20...Q	0.30	2.28	28	5	19.5	59	49	5	66.5	32	44	79	M 6
LWET 25...Q	0.56	3.09	33	6	25	73	60	6.5	83	35	56	95	M 8
LWET 30...Q	0.97	5.04	42	10	31	90	72	9	95.5	40	64.8	106	M10
LWET 35...Q	1.53	6.84	48	11	33	100	82	9	109.5	50	76.6	122	M10

Note(1) : Track rail lengths are shown in Table 11 on page B-67.

(2) : The directions of basic dynamic load rating (C), basic static load rating (C<sub>0</sub>) and static moment rating (T<sub>0</sub>, T<sub>x</sub>, T<sub>y</sub>) are shown in the sketches below. The upper values in the T<sub>x</sub> and T<sub>y</sub> columns apply to one slide unit, and the lower values apply to two slide units in close contact.

Remark 1 : Track rail mounting bolts are not appended. Hexagon socket bolt of JIS B1176 strength division 12.9 or equivalent are recommended. Recommended bolt sizes are shown in Table 6 on page B-64.

2 : For grease nipple specifications, see page 99.

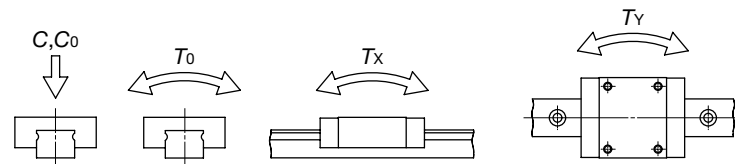

		Dimensions of track rail mm							Basic dynamic load rating <sup>(2)</sup>	Basic static load rating <sup>(2)</sup>	Static moment rating <sup>(2)</sup>		
H <sub>2</sub>	H <sub>3</sub>	W	H <sub>4</sub>	d <sub>3</sub>	d <sub>4</sub>	h	E	F	C N	C <sub>0</sub> N	T <sub>0</sub> N·m	T <sub>x</sub> N·m	T <sub>y</sub> N·m
7	4.5	15	14.5	3.6	6.5	4.5	20	60	6 550	8 610	68.9	53.0 307	53.0 307
9	5.5	20	16	6	9.5	8.5	20	60	10 500	13 400	145	100 557	100 557
10	6.5	23	19	7	11	9	20	60	15 500	19 400	240	175 1 010	175 1 010
10	8	28	25	7	11	9	20	80	21 600	26 400	398	278 1 570	278 1 570
13	10	34	28	9	14	12	20	80	30 500	37 600	687	482 2 530	482 2 530

Example of identification number (For details, see "Identification number and specification".)

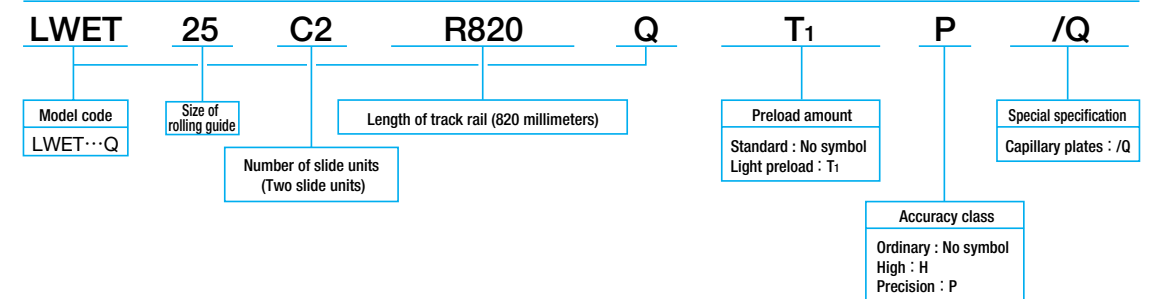

# IKO Low Decibel Linear Way E: Block type

Block type mounted from top  
LWES ...Q

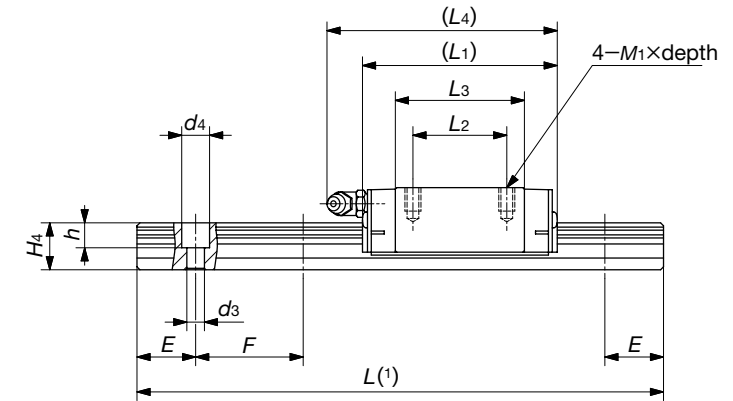
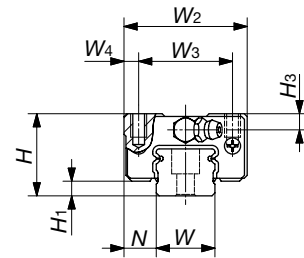

Model number	Mass (Ref.)		Dimensions of assembly mm			Dimensions of slide unit mm						
	Slide unit kg	Track rail kg/m	H	H <sub>1</sub>	N	W <sub>2</sub>	W <sub>3</sub>	W <sub>4</sub>	L <sub>1</sub>	L <sub>2</sub>	L <sub>3</sub>	L <sub>4</sub>
LWES 15...Q	0.14	1.57	24	5	9.5	34	26	4	57	26	38.4	61
LWES 20...Q	0.25	2.28	28	5	11	42	32	5	66.5	32	44	79
LWES 25...Q	0.43	3.09	33	6	12.5	48	35	6.5	83	35	56	95
LWES 30...Q	0.75	5.04	42	10	16	60	40	10	95.5	40	64.8	106
LWES 35...Q	1.20	6.84	48	11	18	70	50	10	109.5	50	76.6	122

M <sub>1</sub> ×depth	H <sub>3</sub>	Dimensions of track rail mm							Basic dynamic load rating <sup>(2)</sup> C N	Basic static load rating <sup>(2)</sup> C <sub>0</sub> N	Static moment rating <sup>(2)</sup>		
		W	H <sub>4</sub>	d <sub>3</sub>	d <sub>4</sub>	h	E	F			T <sub>0</sub> N·m	T <sub>x</sub> N·m	T <sub>y</sub> N·m
M4× 7	4.5	15	14.5	3.6	6.5	4.5	20	60	6 550	8 610	68.9	53.0 307	53.0 307
M5× 8	5.5	20	16	6	9.5	8.5	20	60	10 500	13 400	145	100 557	100 557
M6× 9	6.5	23	19	7	11	9	20	60	15 500	19 400	240	175 1 010	175 1 010
M8×12	8	28	25	7	11	9	20	80	21 600	26 400	398	278 1 570	278 1 570
M8×12	10	34	28	9	14	12	20	80	30 500	37 600	687	482 2 530	482 2 530

Note(1) : Track rail lengths are shown in Table 11 on page B-67.

(2) : The directions of basic dynamic load rating (C), basic static load rating (C<sub>0</sub>) and static moment rating (T<sub>0</sub>, T<sub>x</sub>, T<sub>y</sub>) are shown in the sketches below. The upper values in the T<sub>x</sub> and T<sub>y</sub> columns apply to one slide unit, and the lower values apply to two slide units in close contact.

Remark 1 : Track rail mounting bolts are not appended. Hexagon socket bolt of JIS B1176 strength division 12.9 or equivalent are recommended.

Recommended bolt sizes are shown in Table 6 on page B-64.

2 : For grease nipple specifications, see page 99.

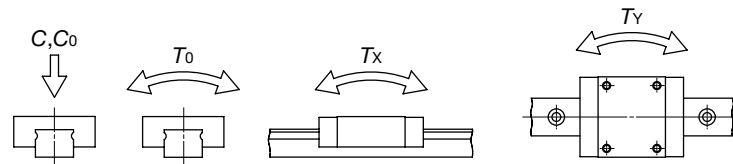

Example of identification number\* (For details, see "Identification number and specification".)

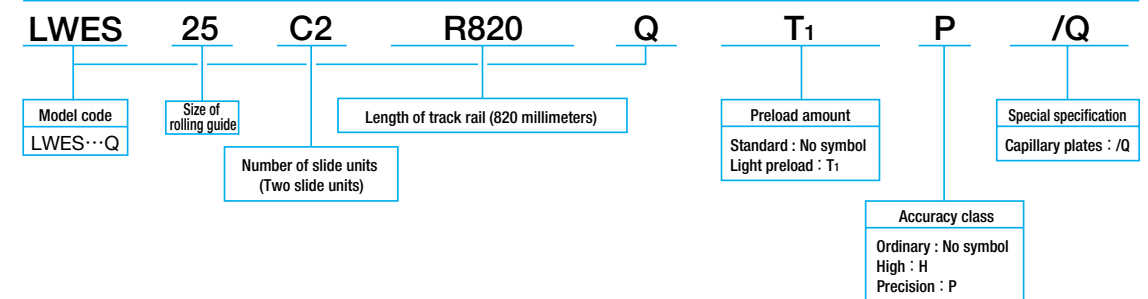

# Linear Way H

LWH...B/LWHT...B/LWHD...B/LWHS...B/LWHY

**IKO** Linear Way H incorporates two rows of large diameter steel balls in four point contact with the raceways and provides stable high accuracy and rigidity in operations even under fluctuating loads with changing direction and magnitude or complex loads. This series features the largest load ratings and rigidity among all ball types. A wide range of variations in shapes and sizes are available for selecting a model suitable for each application.

## Interchangeable

Linear Way H includes interchangeable specification products. The dimensions of slide units and track rails of this specification are individually controlled, so that the slide units and track rails can be combined, added or exchanged freely.

## Flange type and block type

Slide units are available in five different sectional shapes: two flange types for different mounting directions and three narrow block types that are different in height and mounting directions.

## Length of slide unit

A standard type slide unit and a high rigidity long type slide unit both having the same sectional dimensions are available.

## Stainless steel type

The stainless steel type has excellent corrosion resistance and is most suitable for machines and equipment used in clean environments, for example, medical equipment, semiconductor and FPD manufacturing equipment.

## Ultra sealed specification

The track rail of this specification is ground on all surfaces, and is combined with a slide unit with specially designed end seals and under seals. Excellent dust protection performance is provided.

## Miniature size

Miniature size models with track rail widths of 8 mm, 10 mm and 12 mm are available for use in the extended application range of Linear Way H.

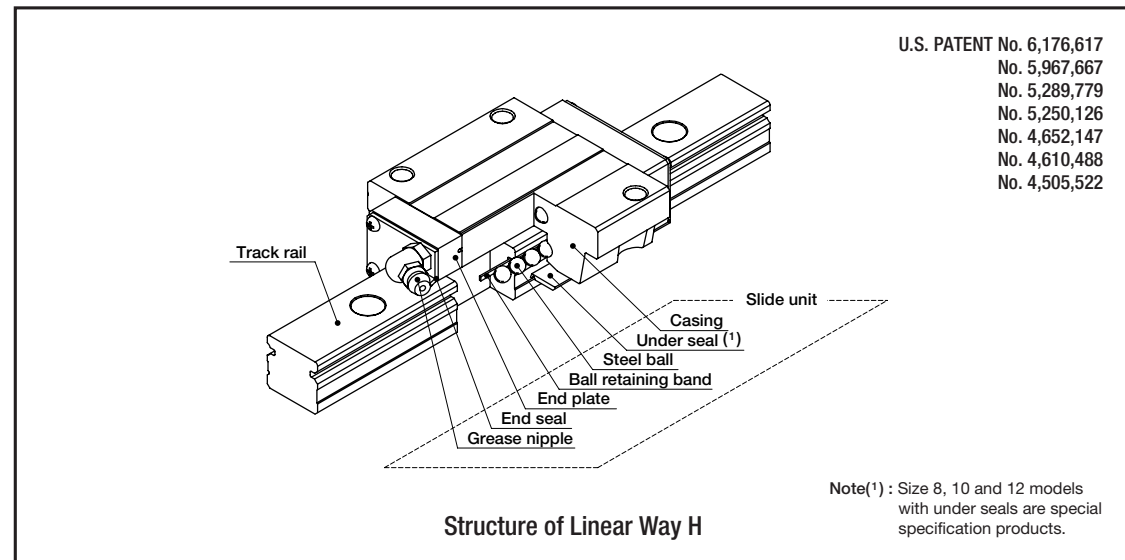

## Linear Way H series

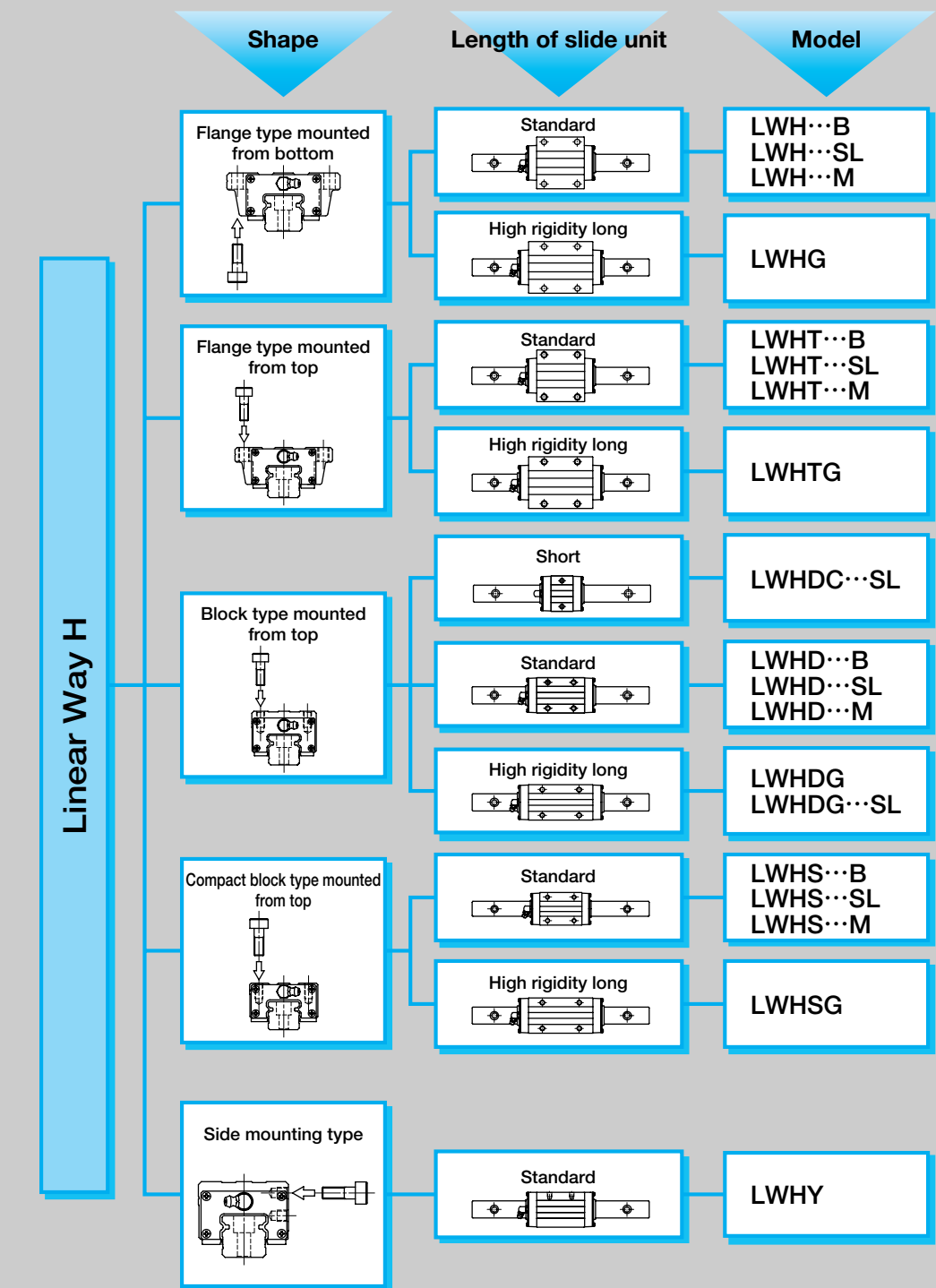

Remark 1 : Models with "SL" are stainless steel type.  
 Remark 2 : Models with "M" are ultra sealed specification products.

B  
 LWH, LWHT, LWHD, LWHS, LWHY



## ● Identification number and specification

The specification of Linear Way H is indicated by the identification number, consisting of a model code, a size, a part code, a seal code, a material symbol, a preload symbol, a classification symbol, an interchangeable code and any supplemental codes. For details of each specification, see page 78.

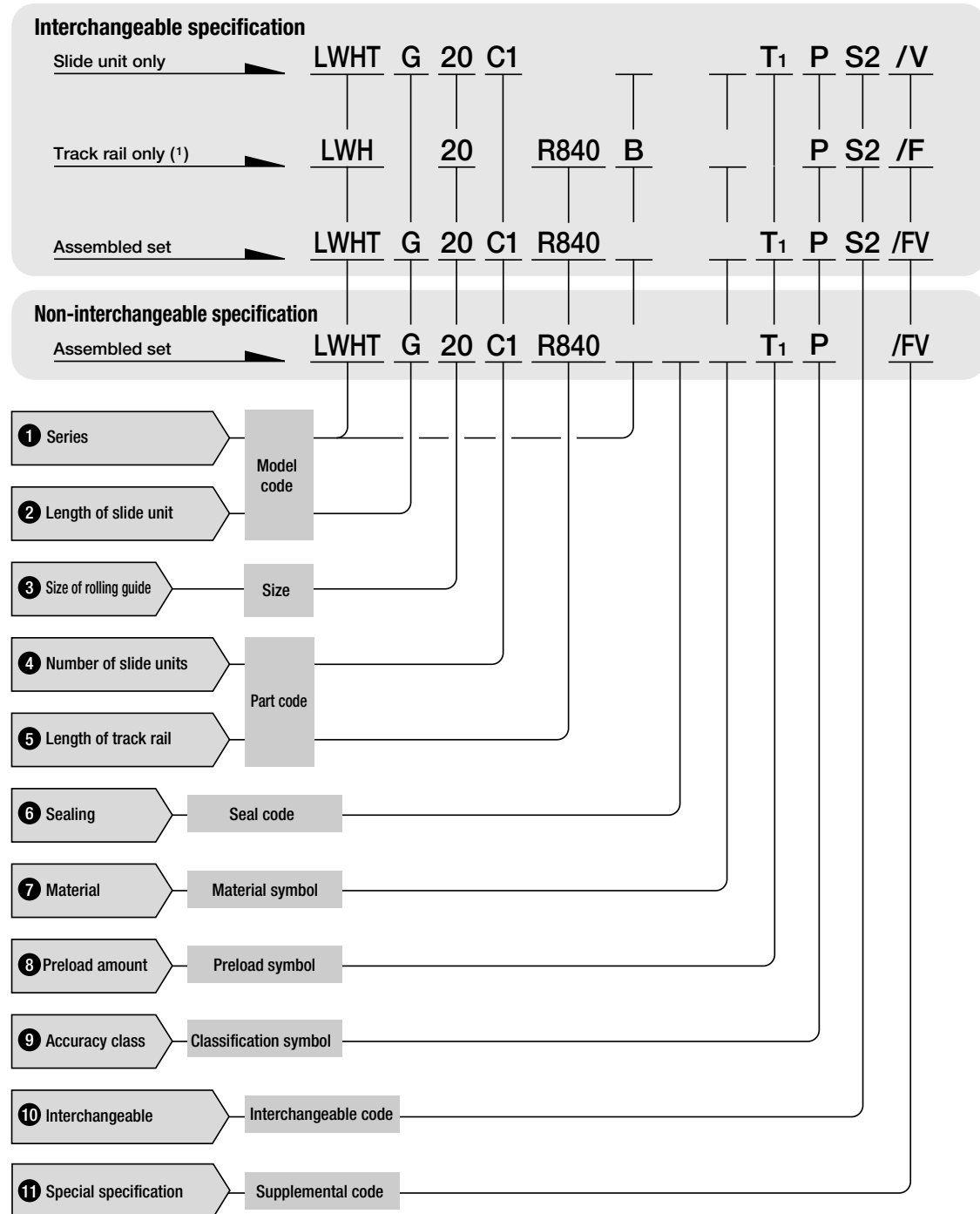

Note(1) : For the model code of a single track rail of interchangeable specification, indicate "LWH...B" (high carbon steel made) or "LWH...SL" (stainless steel made) regardless of the slide unit type to be combined.

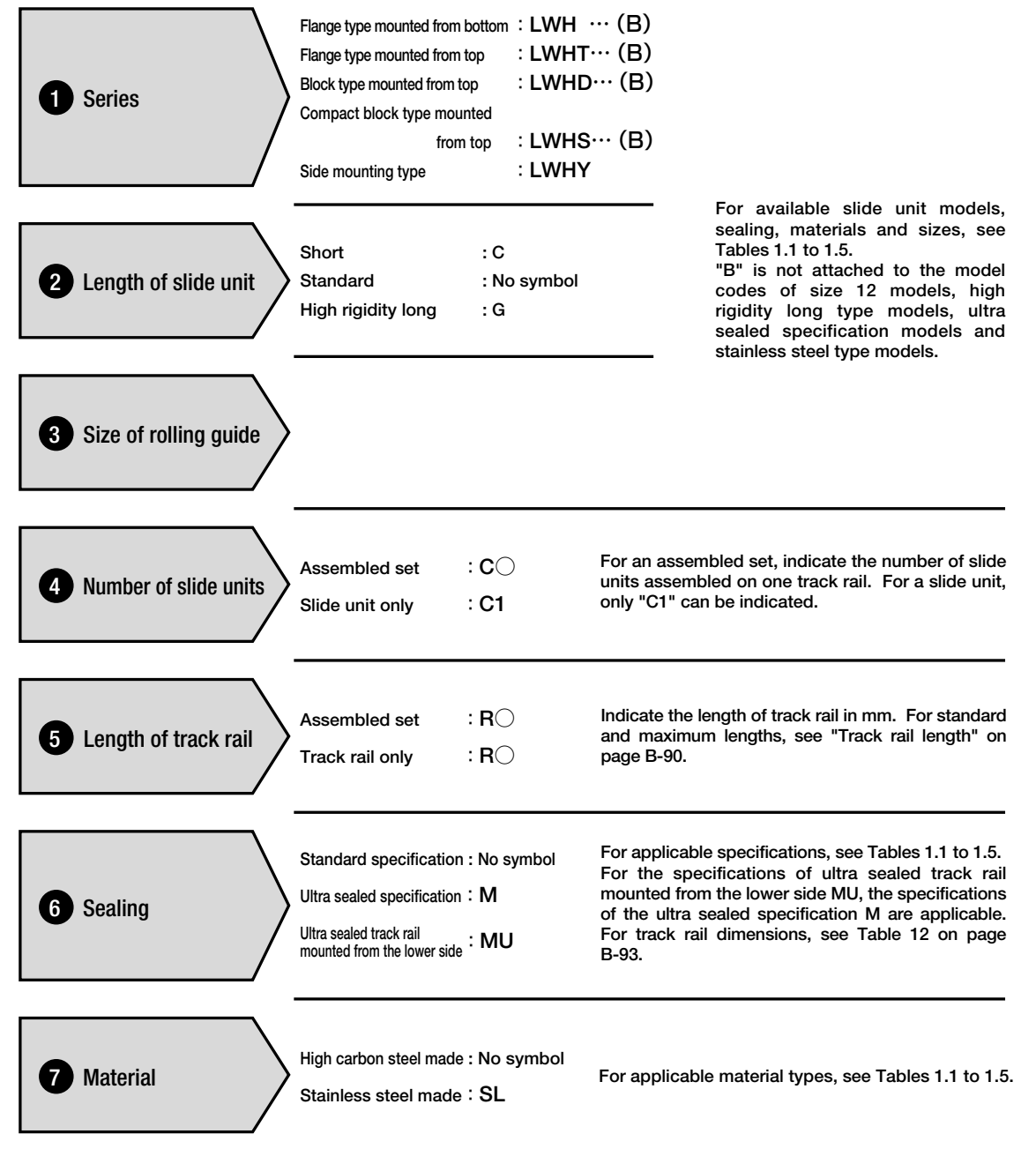

Table 1.1 Models and sizes of Linear Way H flange type mounted from bottom

Size	Model	Standard specification			Ultra sealed specification
		High carbon steel made		Stainless steel made	High carbon steel made
		Standard LWH...B	High rigidity long LWHG	Standard LWH...SL	Standard LWH...M
15		☆	—	☆	○
20		☆	☆	☆	○
25		☆	☆	☆	○
30		☆	☆	☆	○
35		☆	☆	—	○
45		☆	☆	—	○
55		☆	☆	—	—
65		☆	☆	—	—
85		—	○	—	—

Remark : The mark ☆ indicates that interchangeable specification products are available.

Table 1.2 Models and sizes of Linear Way H flange type mounted from top

Size	Model	Standard specification			Ultra sealed specification
		High carbon steel made		Stainless steel made	High carbon steel made
		Standard LWHT...B	High rigidity long LWHTG	Standard LWHT...SL	Standard LWHT...M
8 (1)		—	—	☆	—
10 (1)		—	—	☆	—
12 (1)		☆ (2)	—	☆	—
15		☆	—	☆	○
20		☆	☆	☆	○
25		☆	☆	☆	○
30		☆	☆	☆	○
35		☆	☆	—	○
45		☆	☆	—	○
55		☆	☆	—	—
65		☆	☆	—	—
85		—	○	—	—

Note(1) : This model can also be mounted from the lower side.

(2) : "...B" is not attached to the model code.

Remark : The mark ☆ indicates that interchangeable specification products are available.

Table 1.3 Models and sizes of Linear Way H block type mounted from top

Size	Model	Standard specification					Ultra sealed specification
		High carbon steel made		Stainless steel made			High carbon steel made
		Standard LWHD...B	High rigidity long LWHDG	Short LWHDC...SL	Standard LWHD...SL	High rigidity long LWHDG...SL	Standard LWHD...M
8		—	—	☆	☆	☆	—
10		—	—	☆	☆	☆	—
12		☆ (1)	—	☆	☆	☆	—
15		☆	—	—	—	—	○
25		☆	☆	—	—	—	○
30		☆	☆	—	—	—	○
35		☆	☆	—	—	—	○
45		☆	☆	—	—	—	○
55		☆	☆	—	—	—	—
65		☆	☆	—	—	—	—

Note(1) : "...B" is not attached to the model code.

Remark : The mark ☆ indicates that interchangeable specification products are available.

Table 1.4 Models and sizes of Linear Way H compact block type mounted from top

Size	Model	Standard specification			Ultra sealed specification
		High carbon steel made		Stainless steel made	High carbon steel made
		Standard LWHS...B	High rigidity long LWHSG	Standard LWHS...SL	Standard LWHS...M
15		☆	—	☆	○
20		☆	☆	☆	○
25		☆	☆	☆	○
30		☆	☆	☆	○

Remark : The mark ☆ indicates that interchangeable specification products are available.

Table 1.5 Models and sizes of Linear Way H side mounting type

Size	Model	Standard specification
		High carbon steel made
		Standard LWHY
15		○
20		○
25		○
30		○
35		○
45		○
55		○
65		○

Remark : Only non-interchangeable specification products are available for this type.

**8** Preload amount

Clearance : T<sub>0</sub>  
 Standard : No symbol  
 Light preload : T<sub>1</sub>  
 Medium preload : T<sub>2</sub>  
 Heavy preload : T<sub>3</sub>

Specify this item for an assembled set or a single slide unit. For applicable preload amount, see Table 2. For details of preload amount, see page 86.

**Table 2 Applicable preload types**

Size	Preload type (Symbol)				
	Clearance (T <sub>0</sub> )	Standard (No symbol)	Light preload (T <sub>1</sub> )	Medium preload (T <sub>2</sub> )	Heavy preload (T <sub>3</sub> )
8	○	☆	○	—	—
10	○	☆	○	—	—
12	○	☆	○	—	—
15	—	☆	☆	☆	☆
20	—	☆	☆	☆	☆
25	—	☆	☆	☆	☆
30	—	☆	☆	☆	☆
35	—	☆	☆	☆	☆
45	—	☆	☆	☆	☆
55	—	☆	☆	☆	☆
65	—	☆	☆	☆	☆
85	—	○	○	○	○

Remark 1 : The mark ☆ indicates that it is also applicable to interchangeable specification products.  
 2 : For the stainless steel type, medium preload (T<sub>2</sub>) and heavy preload (T<sub>3</sub>) are not applicable.

**9** Accuracy class

High : H  
 Precision : P  
 Super precision : SP

For applicable accuracy, see Table 3. For the interchangeable specification, combine slide units and track rails of the same class. For details of accuracy, see page 81.

**Table 3 Applicable accuracy class**

Size	Accuracy class (Symbol)		
	High (H)	Precision (P)	Super precision (SP)
8	☆	☆	—
10	☆	☆	—
12	☆	☆	—
15	☆	☆	○
20	☆	☆	○
25	☆	☆	○
30	☆	☆	○
35	☆	☆	○
45	☆	☆	○
55	☆	☆	○
65	☆	☆	○
85	○	○	○

Remark : The mark ☆ indicates that it is also applicable to interchangeable specification products.

**10** Interchangeable code

Select group 1 : S1  
 Select group 2 : S2

Specify this item for interchangeable specification products. Combine track rails and slide units with the same interchangeable code. Performance and accuracy of "S1" group and "S2" group are the same.

**11** Special specification

For applicable special specifications, see Table 4. When several special specifications are required, see Table 5. For details of special specifications, see page 88.

**Table 4 Special specifications**

Special specification	Supplemental code	Assembled set	Track rail	Slide unit	Dimension
Butt-jointing track rail	A	○ (1)	—	—	
Stainless steel end plates	BS	☆ (2)(3)	—	☆ (2)	
Opposite reference surfaces arrangement	D	☆ (3)	—	—	
Specified rail mounting hole positions	E	☆	☆	—	
Caps for rail mounting holes	F	☆ (5)	☆ (5)	—	
Inspection sheet	I	○	—	—	
Female threads for bellows	J	☆ (3)(6)	☆ (6)(7)	☆ (6)(7)	See Table 6.1, Table 6.2, Table 6.3.
Black chrome surface treatment	L	☆ (8)	☆ (6)	—	
Fluorine black chrome surface treatment	LF	☆ (6)(13)	—	—	
Supplied without track rail mounting bolt	MN	☆	☆	—	
No end seal	N	☆ (4)	—	☆	
Rail cover plate	PS	○ (4)(9)(10)	—	—	
Capillary plates	Q	☆ (3)(4)	—	☆	See Table 7.
Seals for special environment	RE	☆ (2)(4)	—	☆ (2)	
Butt-jointing interchangeable track rail	T	☆ (6)(11)	☆ (6)	—	
Under seals <sup>(2)</sup>	U	☆ (12)	—	☆ (12)	See Table 8.
Double end seals	V	☆ (6)	—	☆ (6)	See Table 9.
Matched sets to be used as an assembled group	W	○	—	—	
Specified grease	Y	☆ (13)	—	—	
Scrapers	Z	☆ (6)	—	☆ (6)	See Table 10.

Note<sup>(1)</sup> : Not applicable to size 12 of high carbon steel made models.

(2) : Applicable to size 15, 20, 25 and 30 models.

(3) : Not applicable to the side mounting type (model code: LWHY).

(4) : Not applicable to ultra sealed specification products.

(5) : Not applicable to size 8 and 10 models.

(6) : Not applicable to size 8, 10 and 12 models.

(7) : Not applicable to stainless steel made interchangeable specification products.

(8) : Only "LR" is applicable to size 8, 10 and 12 models.

(9) : Not applicable to size 8, 10, 12, 15 and 20 models.

(10) : Applicable to high carbon steel type.

(11) : Not applicable to non-interchangeable specification products.

(12) : Applicable to size 8, 10 and 12 models.

(13) : Not applicable to size 8, 10 and 12 models of interchangeable specification.

Remark 1 : In the table, the mark ☆ indicates that it is also applicable to interchangeable specification products.

2 : For size 85 models, no special specifications are applicable.

**Table 5 Combination of special specifications**

BS	○																					
D	○	☆																				
E	—	☆	—																			
F	○	☆	☆	☆																		
I	○	○	○	○	○																	
J	○	☆	☆	☆	☆	○																
L	○	☆	☆	☆	☆	○	☆															
LF	○	☆	☆	☆	☆	○	☆	—														
MN	○	☆	☆	☆	☆	○	☆	☆	☆													
N	○	☆	☆	☆	—	○	—	☆	☆	☆												
PS	—	○	○	○	—	○	—	—	—	○	—											
Q	○	☆	☆	☆	☆	○	—	☆	☆	☆	☆	○										
RE	○	☆	☆	☆	☆	○	☆	☆	☆	☆	—	—	☆									
T	—	☆	☆	☆	☆	—	—	☆	☆	☆	☆	—	☆	☆								
U	○	—	☆	☆	☆	○	—	☆	—	☆	—	—	○	—	—							
V	○	☆	☆	☆	☆	○	★	☆	☆	☆	—	○	—	☆	☆	—						
W	○	○	○	—	○	○	○	○	○	○	○	○	○	○	—	○	○					
Y	○	☆	☆	☆	☆	○	☆	☆	☆	☆	☆	☆	—	☆	☆	☆	☆	☆	○			
Z	○	☆	☆	☆	☆	○	★	☆	☆	☆	—	—	—	☆	☆	—	★	○	☆			

Remark 1 : In the table, the mark ☆ indicates that it is also applicable to interchangeable specification products.  
 2 : In the table, the mark — indicates that this combination cannot be made.  
 3 : The combinations marked ★ are applicable to non-interchangeable specification products.  
 For combinations of interchangeable specification products, consult **IKO** for further information.  
 4 : When several special specifications are required, arrange the supplemental codes alphabetically.

Table 6.1 Female threads for bellows for flange type (Supplemental code /J, /JJ)

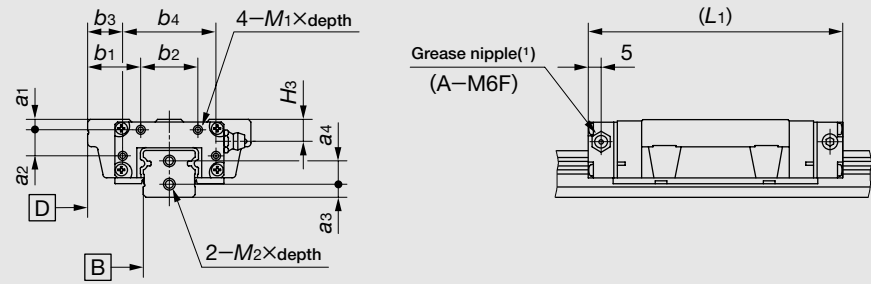

unit : mm

Model number	Slide unit									Track rail		
	a1	a2	b1	b2	b3	b4	M1×depth	L1 <sup>(2)</sup>	H3	a3	a4	M2×depth
LWH (T) 15···B	3	7	15.5	16	9.5	28	M3× 6	83	6.5	4	8	M3× 6
LWH (T) 15···SL								86				
LWH (T) 15···M								86				
LWH (T) 20···B	4	10	20.5	22	13.5	36	M3× 6	99	8.5	5	9	M4× 8
LWH (T) 20···SL								103				
LWH (T) 20···M								103				
LWH (T) G 20								128				
LWH (T) 25···B	4	13	22	26	15	40	M3× 6	110	8.5	5	12	M4× 8
LWH (T) 25···SL								115				
LWH (T) 25···M								115				
LWH (T) G 25								133				
LWH (T) 30···B								128				
LWH (T) 30···SL	5	17	28	34	20	50	M3× 6	133	11	6	14	M4× 8
LWH (T) 30···M								154				
LWH (T) G 30								154				
LWH (T) 35···B	6	20	30	40	20	60	M3× 6	137	13	7	15	M4× 8
LWH (T) 35···M								143				
LWH (T) G 35								165				
LWH (T) 45···B	7	26	35	50	23	74	M4× 8	160	15	8	19	M5×10
LWH (T) 45···M								167				
LWH (T) G 45								203				
LWH (T) 55···B	7	32	40	60	27	86	M4× 8	196	17	8	25	M5×10
LWH (T) G 55								248				
LWH (T) 65···B	10	46	50	70	32	106	M5×10	240	20	10	28	M6×12
LWH (T) G 65								314				

Note<sup>(1)</sup> : The specification and mounting position of grease nipple are different from those of the standard specification product.  
 Size 15 models are provided with a special specification grease nipple (NPB2 type). For details of dimensions, consult **IJKO** for further information.  
<sup>(2)</sup> : The values are for the slide unit with female threads for bellows at both ends.

Table 6.2 Female threads for bellows for block type (Supplemental code /J, /JJ)

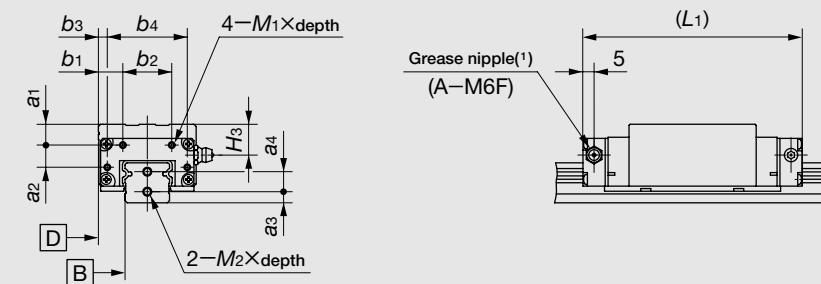

unit : mm

Model number	Slide unit									Track rail		
	a1	a2	b1	b2	b3	b4	M1×depth	L1 <sup>(2)</sup>	H3	a3	a4	M2×depth
LWHD 15···B	7	7	9	16	3	28	M3× 6	83	10.5	4	8	M3× 6
LWHD 15···M								86				
LWHD 25···B	8	13	11	26	4	40	M3× 6	110	12.5	5	12	M4× 8
LWHD 25···M								115				
LWHDG 25								133				
LWHD 30···B	8	17	13	34	5	50	M3× 6	128	14	6	14	M4× 8
LWHD 30···M								133				
LWHDG 30								154				
LWHD 35···B	13	20	15	40	5	60	M3× 6	137	20	7	15	M4× 8
LWHD 35···M								143				
LWHDG 35								165				
LWHD 45···B	17	26	18	50	6	74	M4× 8	160	25	8	19	M5×10
LWHD 45···M								167				
LWHDG 45								203				
LWHD 55···B	17	32	20	60	7	86	M4× 8	196	27	8	25	M5×10
LWHDG 55								248				
LWHD 65···B	10	46	28	70	10	106	M5×10	240	20	10	28	M6×12
LWHDG 65								314				

Note<sup>(1)</sup> : The specification and mounting position of grease nipple are different from those of the standard specification product.  
 Size 15 models are provided with a special specification grease nipple (NPB2 type). For details of dimensions, consult **IJKO** for further information.

<sup>(2)</sup> : The values are for the slide unit with female threads for bellows at both ends.

Table 6.3 Female threads for bellows for compact block type (Supplemental code /J, /JJ)

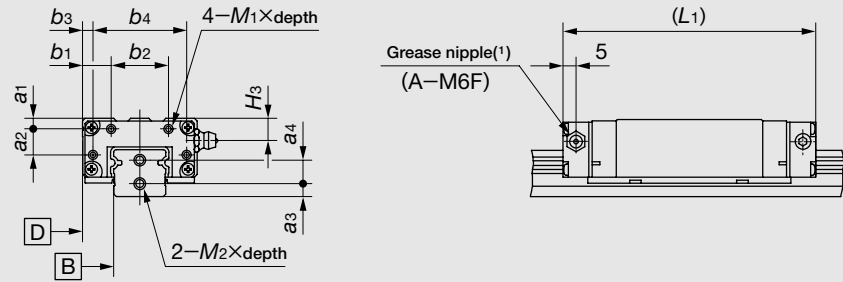

unit : mm

Model number	Slide unit									Track rail		
	a1	a2	b1	b2	b3	b4	M1×depth	L1 <sup>(2)</sup>	H3	a3	a4	M2×depth
LWHS 15··B												
LWHS 15··SL	3	7	9	16	3	28	M3×6	83	6.5	4	8	M3×6
LWHS 15··M								86				
LWHS 20··B												
LWHS 20··SL	4	10	11	22	4	36	M3×6	99	8.5	5	9	M4×8
LWHS 20··M								103				
LWHSG 20								128				
LWHS 25··B												
LWHS 25··SL	4	13	11	26	4	40	M3×6	110	8.5	5	12	M4×8
LWHS 25··M								115				
LWHSG 25								133				
LWHS 30··B												
LWHS 30··SL	5	17	13	34	5	50	M3×6	128	11	6	14	M4×8
LWHS 30··M								133				
LWHSG 30								154				

Note<sup>(1)</sup> : The specification and mounting position of grease nipple are different from those of the standard specification product. Size 15 models are provided with a special specification grease nipple (NPB2 type). For details of dimensions, consult **I KO** for further information.

<sup>(2)</sup> : The values are for the slide unit with female threads for bellows at both ends.

Table 7 Slide unit with capillary plates (Supplemental code /Q)

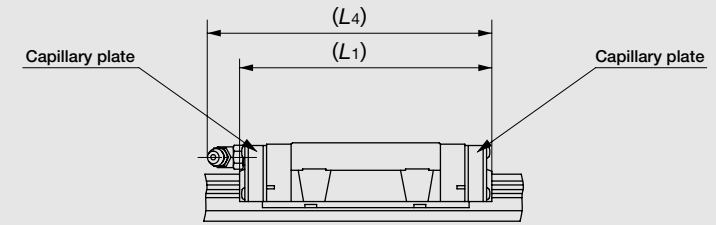

unit : mm

Model number	L1	L4	Model number	L1	L4
LWHDC 8··SL	26	—	LWH 25··B	105	117
LWHD 8··SL	32	—	LWH 25··SL	127	139
LWHDG 8··SL	39	—	LWHG 25	125	135
LWHDC 10··SL	34	—	LWH 30··B	151	161
LWHD 10··SL	42	—	LWH 30··SL	134	146
LWHDG 10··SL	50	—	LWHG 30	162	174
LWHDC 12··SL	44	48	LWH 35··B	160	170
LWHD 12	56	60	LWHG 35	203	213
LWHDG 12··SL	68	72	LWH 45··B	196	207
LWH 15··B	75	78	LWH 55··B	248	258
LWH 15··SL	92	105	LWHG 55	246	253
LWH 20··B	121	134	LWH 65··B	320	327
LWH 20··SL			LWHG 65		
LWHG 20					

Remark : The above table shows representative model numbers but is applicable to all models of the same size.

Table 8 H<sub>1</sub> dimension of slide unit with under seals (Supplemental code /U)

unit : mm

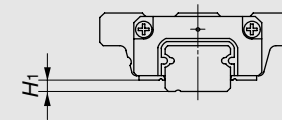

Model number	H <sub>1</sub>
LWH 8··SL	1.5
LWH 10··SL	1.8
LWH 12	3.2

Remark 1 : The above table shows representative model numbers but is applicable to all models of the same size.  
2 : H<sub>1</sub> dimension of size 12 models is the same as the dimension without under seals.

Table 9 Slide unit with double end seals (Supplemental code /V, /VV)

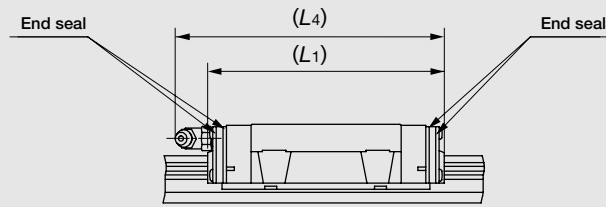

unit : mm

Model number	L1	L4
LWH 15···B	72	77
LWH 15···SL		
LWH 15···M	71	76
LWH 20···B	91	104
LWH 20···SL		
LWH 20···M	90	103
LWHG 20	119	133
LWH 25···B	104	116
LWH 25···SL		
LWH 25···M	103	115
LWHG 25	127	139
LWH 30···B	122	134
LWH 30···SL		
LWH 30···M	121	133
LWHG 30	148	160

Model number	L1	L4
LWH 35···B	133	146
LWH 35···M		
LWHG 35	161	173
LWH 45···B	159	170
LWH 45···M	158	
LWHG 45	202	213
LWH 55···B	196	206
LWHG 55	247	258
LWH 65···B	241	251
LWHG 65	316	326

Remark 1 : The above table shows representative model numbers but is applicable to all models of the same size.  
 2 : The values are for the slide unit with double end seals at both ends.

Table 10 Slide unit with scrapers (Supplemental code /Z, /ZZ)

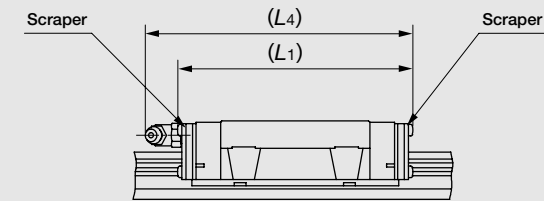

unit : mm

Model number	L1	L4
LWH 15···B	73	75
LWH 15···SL		
LWH 15···M	72	74
LWH 20···B	91	104
LWH 20···SL		
LWH 20···M	90	101
LWHG 20	119	133
LWH 25···B	104	116
LWH 25···SL		
LWH 25···M	103	113
LWHG 25	126	139

Model number	L1	L4
LWH 30···B	124	135
LWH 30···SL		
LWH 30···M	123	131
LWHG 30	150	161
LWH 35···B	133	146
LWH 35···M		
LWHG 35	161	174
LWH 45···B	160	171
LWH 45···M	159	170
LWHG 45	203	214
LWH 55···B	196	207
LWHG 55	248	258
LWH 65···B	242	252
LWHG 65	317	326

Remark 1 : The above table shows representative model numbers but is applicable to all models of the same size.  
 2 : The values are for the slide unit with scrapers at both ends.

## Track rail length

Standard and maximum lengths of track rails are shown in Tables 11.1, 11.2 and 11.3. Track rails of any length are also available. Simply indicate the required length of track rail in mm in the identification number. For the tolerances of *E* dimension and track rail length, consult **IJKO** for further information.

- For track rails of non-interchangeable specification longer than the maximum length shown in Tables 11.1, 11.2 and 11.3, butt-jointing track rails are available upon request. In this case, indicate "/A" in the identification number.
- *E* dimensions at both ends are the same and are within the standard range of *E* unless otherwise specified. To change these dimensions, specify the specified rail mounting hole positions "/E" of special specification. For details, see page 91.

Table 11.1 Standard and maximum lengths of high carbon steel track rails

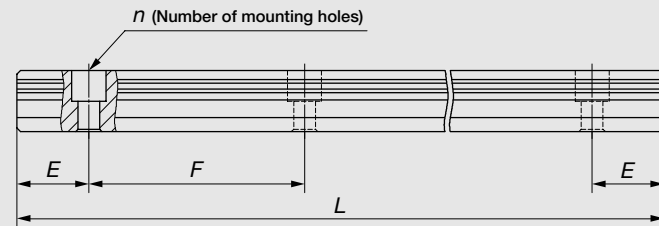

unit : mm

Item	Model number	LWH 12	LWH 15...B	LWH 20...B	LWH 25...B	LWH 30...B
Standard length <i>L</i> ( <i>n</i> )		80( 2)	180( 3)	240( 4)	240( 4)	480( 6)
		160( 4)	240( 4)	480( 8)	480( 8)	640( 8)
		240( 6)	360( 6)	660(11)	660(11)	800(10)
		320( 8)	480( 8)	840(14)	840(14)	1 040(13)
		400(10)	660(11)	1 020(17)	1 020(17)	1 200(15)
		480(12)	900(15)	1 200(20)	1 200(20)	1 520(19)
		560(14)	1 200(20)	1 500(25)	1 500(25)	2 000(25)
		640(16)			1 980(33)	
Pitch of mounting holes <i>F</i>		40	60	60	60	80
<i>E</i>		20	30	30	30	40
Standard range of <i>E</i> <sup>(1)</sup>	incl.	5.5	7	8	9	10
	under	25.5	37	38	39	50
Maximum length <sup>(2)</sup>		1 480	1 500 (3 000)	1 980 (3 000)	3 000 (3 960)	2 960 (4 000)
Item	Model number	LWH 35...B	LWH 45...B	LWH 55...B	LWH 65...B	
Standard length <i>L</i> ( <i>n</i> )		480( 6)	840( 8)	840( 7)	1 500(10)	
		640( 8)	1 050(10)	1 200(10)	1 950(13)	
		800(10)	1 260(12)	1 560(13)	3 000(20)	
		1 040(13)	1 470(14)	1 920(16)		
		1 200(15)	1 995(19)	3 000(25)		
	1 520(19)					
Pitch of mounting holes <i>F</i>		80	105	120	150	
<i>E</i>		40	52.5	60	75	
Standard range of <i>E</i> <sup>(1)</sup>	incl.	10	12.5	15	17	
	under	50	65	75	92	
Maximum length <sup>(2)</sup>		2 960 (4 000)	2 940 (3 990)	3 000 (3 960)	3 000 (3 900)	

Note<sup>(1)</sup> : Not applicable to the track rail with female threads for bellows (supplemental code "/J").

<sup>(2)</sup> : Track rails with the maximum lengths in parentheses can be manufactured. Consult **IJKO** for further information.

Remark : The above table shows representative model numbers but is applicable to all models of the same size. For the ultra sealed specification, see Table 11.3 on page B-92.

Table 11.2 Standard and maximum lengths of stainless steel track rails

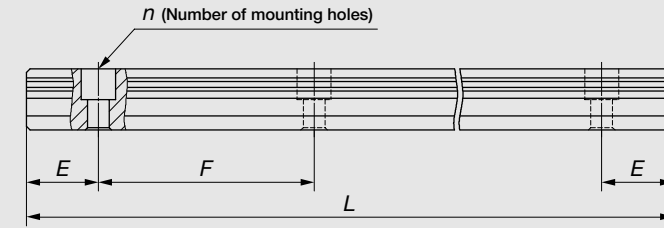

unit : mm

Item	Model number	LWH 8...SL	LWH 10...SL	LWH 12...SL	LWH 15...SL
Standard length <i>L</i> ( <i>n</i> )		40( 2)	50( 2)	80( 2)	180( 3)
		80( 4)	100( 4)	160( 4)	240( 4)
		120( 6)	150( 6)	240( 6)	360( 6)
		160( 8)	200( 8)	320( 8)	480( 8)
		200(10)	250(10)	400(10)	660(11)
		240(12)	300(12)	480(12)	
		280(14)	350(14)	560(14)	
			400(16)	640(16)	
		450(18)	720(18)		
		500(20)			
Pitch of mounting holes <i>F</i>		20	25	40	60
<i>E</i>		10	12.5	20	30
Standard range of <i>E</i> <sup>(1)</sup>	incl.	4.5	5	5.5	7
	under	14.5	17.5	25.5	37
Maximum length <sup>(2)</sup>		480 (1 000)	850 (1 000)	1 000 (1 480)	1 200 (1 500)
Item	Model number	LWH 20...SL	LWH 25...SL	LWH 30...SL	
Standard length <i>L</i> ( <i>n</i> )		240( 4)	240( 4)	480( 6)	
		480( 8)	480( 8)	640( 8)	
		660(11)	660(11)	800(10)	
		840(14)	840(14)	1 040(13)	
Pitch of mounting holes <i>F</i>		60	60	80	
<i>E</i>		30	30	40	
Standard range of <i>E</i> <sup>(1)</sup>	incl.	8	9	10	
	under	38	39	50	
Maximum length <sup>(2)</sup>		1 200 (1 980)	1 200 (1 980)	1 200 (2 000)	

Note<sup>(1)</sup> : Not applicable to the track rail with female threads for bellows (supplemental code "/J").

<sup>(2)</sup> : Track rails with the maximum lengths shown in parentheses can also be manufactured. Consult **IJKO** for further information.

Remark : The above table shows representative model numbers but is applicable to all models of the same size.



Table 11.3 Standard and maximum lengths of ultra sealed type high carbon steel track rails

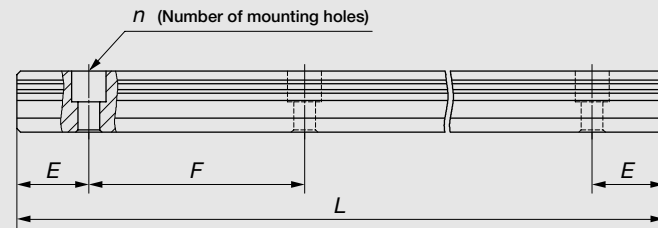

unit : mm

Item	Model number	LWH 15...M	LWH 20...M	LWH 25...M	LWH 30...M	LWH 35...M	LWH 45...M
Standard length $L(n)$		180( 3)	240( 4)	240( 4)	480( 6)	480( 6)	840( 8)
		240( 4)	480( 8)	480( 8)	640( 8)	640( 8)	1 050(10)
		360( 6)	660(11)	660(11)	800(10)	800(10)	1 260(12)
		480( 8)	840(14)	840(14)	1 040(13)	1 040(13)	1 470(14)
		660(11)	1 020(17)	1 020(17)	1 200(15)	1 200(15)	1 995(19)
		1 200(20)	1 200(20)	1 520(19)	1 520(19)		
Pitch of mounting holes $F$		60	60	60	80	80	105
$E$		30	30	30	40	40	52.5
Standard range of $E^{(1)}$	incl.	7	8	9	10	10	12.5
	under	37	38	39	50	50	65
Maximum length		1 500	1 980	3 000	2 960	2 960	2 940
Maximum number of butt-jointing rails		3	3	3	3	3	3
Maximum length of butt-jointing rails		4 200	5 640	8 700	8 480	8 480	8 295

Note<sup>(1)</sup> : Not applicable to the track rail with female threads for bellows (supplemental code "J").  
 Remark : The above table shows representative model numbers but is applicable to all models of the same size.

## ● Specification of ultra sealed type track rail mounted from the lower side

In this specification, aluminum caps are press-fitted into the track rail mounting holes in advance and the track rail is fixed from the mounting surface side. As the top surface of the track rail is flat, close contact with seals can be obtained, further improving the sealing effect.

Table 12 Dimensions of ultra sealed type track rails mounted from the lower side

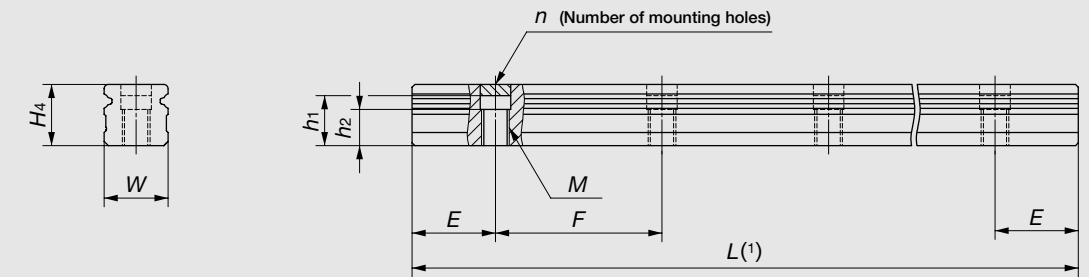

Model number	Mass (Ref.) kg/m	Dimensions mm						
		$W$	$H_4$	$E$	$F$	$M$	$h_1^{(2)}$	$h_2$
LWH 15...MU	1.47	15	15	30	60	M 6	12	9
LWHT 15...MU								
LWHD 15...MU								
LWHS 15...MU								
LWH 20...MU	2.56	20	18	30	60	M 8	13.5	9.5
LWHT 20...MU								
LWHS 20...MU								
LWH 25...MU	3.50	23	22	30	60	M10	18	13
LWHT 25...MU								
LWHD 25...MU								
LWHS 25...MU								
LWH 30...MU	4.82	28	25	40	80	M12	20	13
LWHT 30...MU								
LWHD 30...MU								
LWHS 30...MU								
LWH 35...MU	6.85	34	28	40	80	M12	23	16
LWHT 35...MU								
LWHD 35...MU								
LWH 45...MU	10.7	45	34	52.5	105	M16	29	17
LWHT 45...MU								
LWHD 45...MU								

Note<sup>(1)</sup> : For the track rail length, see Table 11.3 on page B-92.  
<sup>(2)</sup> : The mounting bolt length should be less than the  $h_1$  dimension.  
 Remark : The track rail mounting bolts are not appended.

Flange type mounted from bottom

- LWH ...B
- LWHG
- LWH ...SL (Stainless steel made)
- LWH ...M (Ultra sealed type)

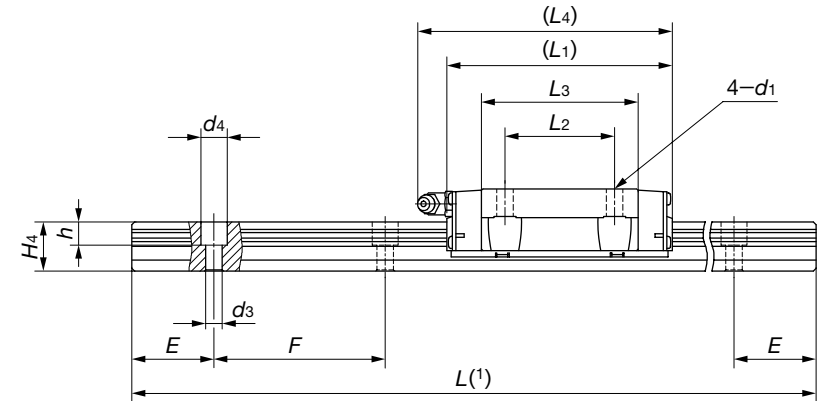
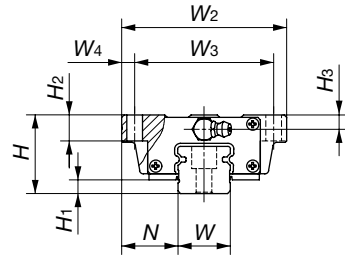

Model number	Interchangeable	Mass (Ref.)		Dimensions of assembly mm			Dimensions of slide unit mm							
		Slide unit kg	Track rail kg/m	H	H <sub>1</sub>	N	W <sub>2</sub>	W <sub>3</sub>	W <sub>4</sub>	L <sub>1</sub>	L <sub>2</sub>	L <sub>3</sub>	L <sub>4</sub>	d <sub>1</sub>
LWH 15...B	☆	0.22	1.47	24	4.5	16	47	38	4.5	66	30	44.6	69	4.5
LWH 15...SL	☆													
LWH 15...M														
LWH 20...B	☆	0.48	2.56	30	5	21.5	63	53	5	83	40	57.2	95	6
LWH 20...SL	☆													
LWH 20...M														
LWHG 20	☆	0.71								112		86	124	
LWH 25...B	☆	0.70	3.50	36	6.5	23.5	70	57	6.5	95	45	64.7	106	7
LWH 25...SL	☆													
LWH 25...M														
LWHG 25	☆	0.93								118		87.4	129	

		Dimensions of track rail mm							Mounting bolt for track rail mm	Basic dynamic load rating <sup>(2)</sup>	Basic static load rating <sup>(2)</sup>	Static moment rating <sup>(2)</sup>		
H <sub>2</sub>	H <sub>3</sub>	W	H <sub>4</sub>	d <sub>3</sub>	d <sub>4</sub>	h	E	F	Bolt size x length	C N	C <sub>0</sub> N	T <sub>0</sub> N·m	T <sub>X</sub> N·m	T <sub>Y</sub> N·m
7	4.5	15	15	4.5	8	6	30	60	M4×16	11 600	13 400	112	95.6 556	95.6 556
10	5.5	20	18	6	9.5	8.5	30	60	M5×18	18 100	21 100	232	195 1 090	195 1 090
10	6.5	23	22	7	11	9	30	60	M6×22	25 200	28 800	362	309 1 690	309 1 690
										30 800	38 300	483	533 2 740	533 2 740

Note<sup>(1)</sup>: Track rail lengths are shown in Table 11.1 on page B-90, Table 11.2 on page B-91 and Table 11.3 on page B-92.  
<sup>(2)</sup>: The directions of basic dynamic load rating (C), basic static load rating (C<sub>0</sub>) and static moment rating (T<sub>0</sub>, T<sub>X</sub>, T<sub>Y</sub>) are shown in the sketches below. The upper values in the T<sub>X</sub> and T<sub>Y</sub> columns apply to one slide unit, and the lower values apply to two slide units in close contact.

Remark 1: The mark ☆ indicates that interchangeable specification products are available.  
 2: The appended track rail mounting bolts are hexagon socket head bolts of JIS B 1176 or equivalent.  
 For stainless steel type Linear Way H, stainless steel bolts are appended.  
 3: For grease nipple specifications, see page 99.

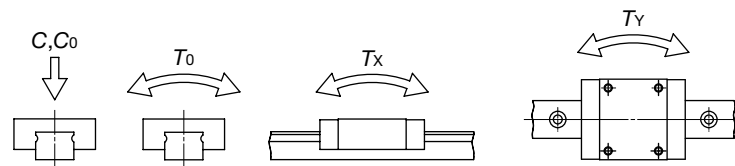

Example of identification number of assembled set (For details, see "Identification number and specification".)

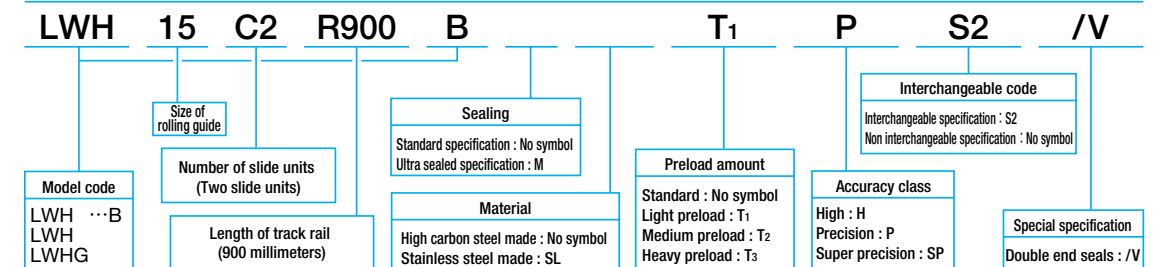

# IKO Linear Way H : Flange type

Flange type mounted from bottom  
**LWH ...B**  
**LWHG**  
**LWH ...SL**(Stainless steel made)  
**LWH ...M**(Ultra sealed type)

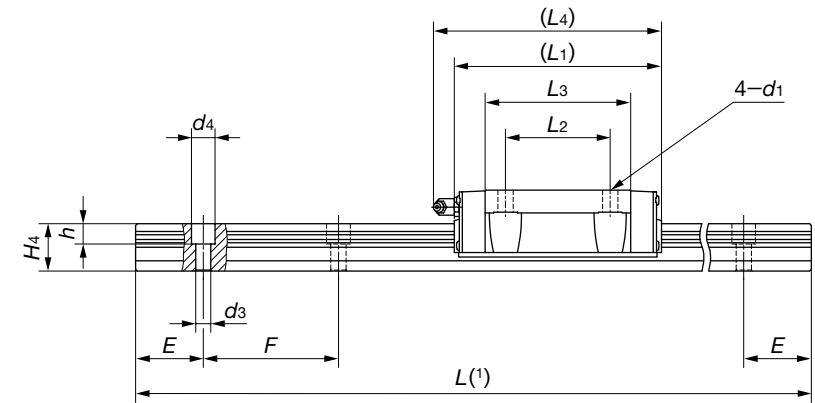
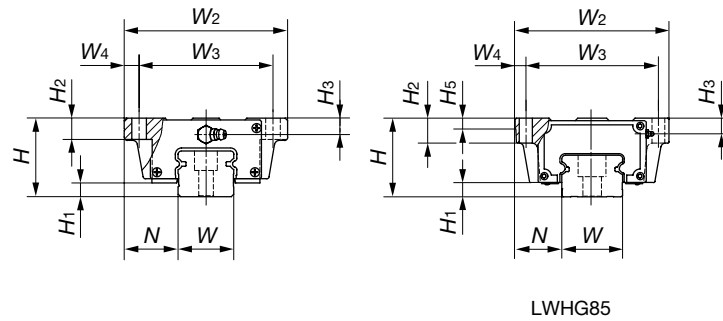

Model number	Interchangeable	Mass (Ref.)		Dimensions of assembly mm			Dimensions of slide unit mm							
		Slide unit kg	Track rail kg/m	H	H <sub>1</sub>	N	W <sub>2</sub>	W <sub>3</sub>	W <sub>4</sub>	L <sub>1</sub>	L <sub>2</sub>	L <sub>3</sub>	L <sub>4</sub>	d <sub>1</sub>
LWH 30...B	☆	1.28	4.82	42	7	31	90	72	9	113	52	80.6	124	9
LWH 30...SL	☆													
LWH 30...M														
LWHG 30	☆	1.69								139		106.6	150	
LWH 35...B	☆	1.79	6.85	48	8	33	100	82	9	123	62	86.2	135	9
LWH 35...M														
LWHG 35	☆													
LWH 45...B	☆	3.17	10.7	60	10	37.5	120	100	10	147	80	103.4	158	11
LWH 45...M														
LWHG 45	☆													
LWH 55...B	☆	5.30	15.5	70	13	43.5	140	116	12	183	95	132	194	14
LWHG 55	☆													
LWH 65...B	☆													
LWHG 65	☆	17.6								303		238.8	313	
LWHG 85		25.9	34.6	110	16	65	215	185	15	318	140	240	—	18

			Dimensions of track rail mm							Mounting bolt for track rail mm	Basic dynamic load rating <sup>(2)</sup>	Basic static load rating <sup>(2)</sup>	Static moment rating <sup>(2)</sup>		
H <sub>2</sub>	H <sub>3</sub>	H <sub>5</sub>	W	H <sub>4</sub>	d <sub>3</sub>	d <sub>4</sub>	h	E	F	Bolt size x length	C N	C <sub>0</sub> N	T <sub>0</sub> N·m	T <sub>X</sub> N·m	T <sub>Y</sub> N·m
10	8	—	28	25	9	14	12	40	80	M 8×28	35 400	40 700	623	536 2 820	536 2 820
											42 700	53 200	814	894 4 460	894 4 460
13	10	—	34	28	9	14	12	40	80	M 8×28	48 700	53 700	823	631 3 480	579 3 190
											59 500	71 600	1 100	1 090 5 570	1 000 5 110
15	13	—	45	34	14	20	17	52.5	105	M12×35	74 600	80 200	1 610	1 150 6 190	1 160 5 690
											95 200	114 000	2 280	2 240 11 100	2 050 10 200
17	14	—	53	41	16	23	20	60	120	M14×45	113 000	121 000	2 870	11 600 10 600	10 600 3 780
											142 000	168 000	3 970	4 120 20 200	18 500 18 500
23	20	—	63	48	18	26	22	75	150	M16×50	176 000	184 000	5 180	4 130 22 000	3 790 20 200
											229 000	269 000	7 560	8 530 41 500	7 810 38 100
30	22	15	85	58	26	39	30	90	180	M24×60	374 000	384 000	11 900	11 100 11 100	11 100 55 300

Note<sup>(1)</sup> : Track rail lengths are shown in Table 11.1 on page B-90, Table 11.2 on page B-91 and Table 11.3 on page B-92.  
<sup>(2)</sup> : The directions of basic dynamic load rating (C), basic static load rating (C<sub>0</sub>) and static moment rating (T<sub>0</sub>, T<sub>X</sub>, T<sub>Y</sub>) are shown in the sketches below. The upper values in the T<sub>X</sub> and T<sub>Y</sub> columns apply to one slide unit, and the lower values apply to two slide units in close contact.  
 Remark 1 : The mark ☆ indicates that interchangeable specification products are available.  
 2 : The appended track rail mounting bolts are hexagon socket head bolts of JIS B 1176 or equivalent.  
 For stainless steel type Linear Way H, stainless steel bolts are appended.  
 3 : For grease nipple specifications, see page 99.

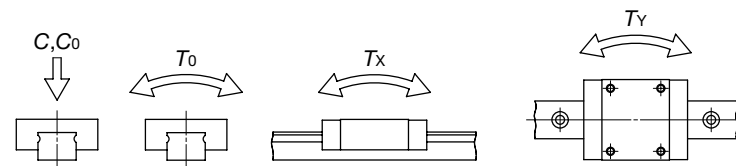

Example of identification number of assembled set (For details, see "Identification number and specification".)

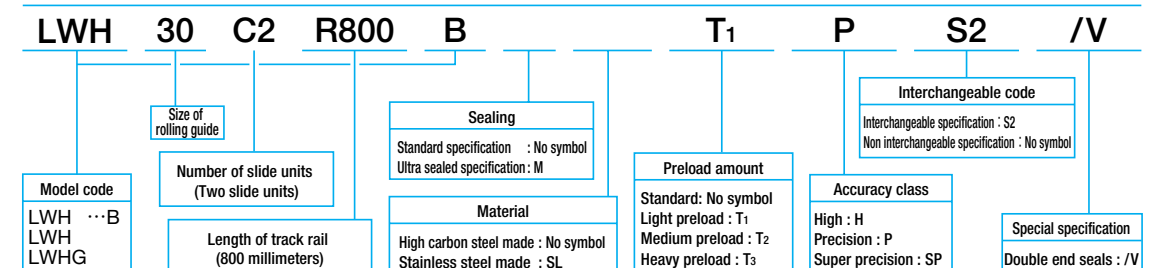

# IKO Linear Way H : Flange type

Flange type mounted from top  
**LWHT ...B**  
**LWHTG**  
**LWHT ...SL** (Stainless steel made)  
**LWHT ...M** (Ultra sealed type)

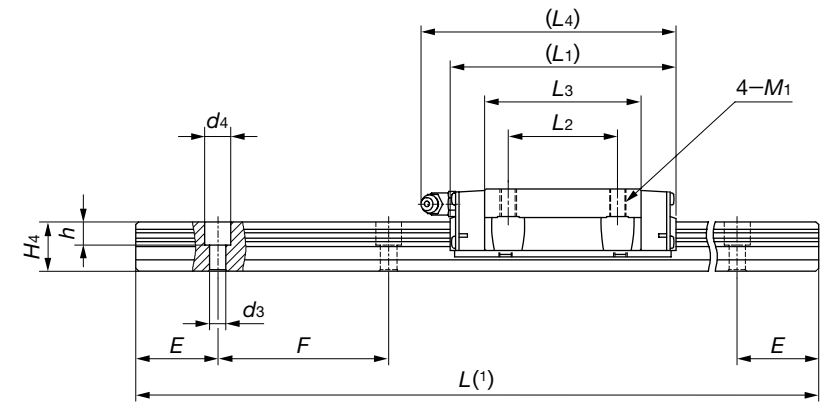
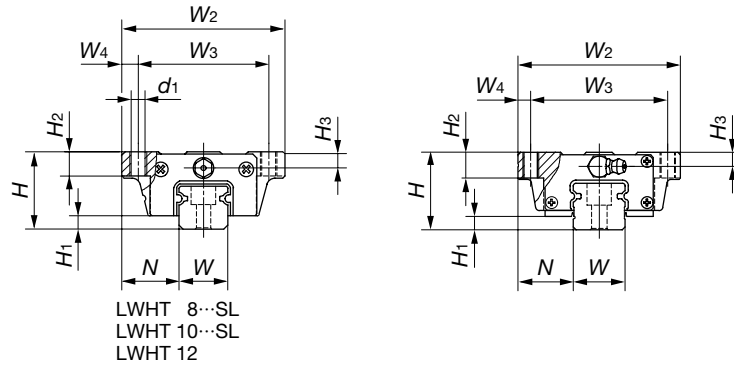

Model number	Interchangeable	Mass (Ref.)		Dimensions of assembly mm			Dimensions of slide unit mm							
		Slide unit kg	Track rail kg/m	H	H <sub>1</sub>	N	W <sub>2</sub>	W <sub>3</sub>	W <sub>4</sub>	L <sub>1</sub>	L <sub>2</sub>	L <sub>3</sub>	L <sub>4</sub>	d <sub>1</sub> <sup>(3)</sup>
LWHT 8...SL	☆	0.015	0.32	10	2.1	8	24	19	2.5	24	10	15.3	—	1.9
LWHT 10...SL	☆	0.032	0.47	12	2.4	10	30	24	3	32	12	21.4	—	2.6
LWHT 12	☆	0.11	0.86	19	3.2	14	40	32	4	46	15	31.6	50	3.4
LWHT 12...SL	☆													
LWHT 15...B	☆	0.22	1.47	24	4.5	16	47	38	4.5	66	30	44.6	69	—
LWHT 15...SL	☆													
LWHT 15...M		0.48	2.56	30	5	21.5	63	53	5	83	40	57.2	95	—
LWHT 20...B	☆													
LWHT 20...SL	☆													
LWHT 20...M														
LWHTG 20	☆	0.71								112		86	124	
LWHT 25...B	☆	0.70	3.50	36	6.5	23.5	70	57	6.5	95	45	64.7	106	—
LWHT 25...SL	☆													
LWHT 25...M														
LWHTG 25	☆	0.93								118		87.4	129	

			Dimensions of track rail mm							Mounting bolt for track rail mm	Basic dynamic load rating <sup>(2)</sup>	Basic static load rating <sup>(2)</sup>	Static moment rating <sup>(2)</sup>		
M <sub>1</sub>	H <sub>2</sub>	H <sub>3</sub>	W	H <sub>4</sub>	d <sub>3</sub>	d <sub>4</sub>	h	E	F	Bolt size x length	C N	C <sub>0</sub> N	T <sub>0</sub> N·m	T <sub>X</sub> N·m	T <sub>Y</sub> N·m
M2.3	3.5	2	8	6	2.4	4.2	2.3	10	20	M2×8	1 510	2 120	8.8	5.5 32.0	4.7 26.9
M3	4.5	2.5	10	7	3.5	6	3.5	12.5	25	M3×8	2 640	3 700	19.2	13.3 73.8	11.1 61.9
M4	6	4	12	10.5	3.5	6	4.5	20	40	M3×12	6 260	8 330	51.6	44.7 237	37.5 199
M5	7	4.5	15	15	4.5	8	6	30	60	M4×16	11 600	13 400	112	95.6 556	95.6 556
M6	10	5.5	20	18	6	9.5	8.5	30	60	M5×18	18 100	21 100	232	195 1 090	195 1 090
M8	10	6.5	23	22	7	11	9	30	60	M6×22	24 100	31 700	349	421 2 140	421 2 140
											25 200	28 800	362	309 1 690	309 1 690
											30 800	38 300	483	533 2 740	533 2 740

Note<sup>(1)</sup>: Track rail lengths are shown in Table 11.1 on page B-90, Table 11.2 on page B-91 and Table 11.3 on page B-92.  
<sup>(2)</sup>: The directions of basic dynamic load rating (C), basic static load rating (C<sub>0</sub>) and static moment rating (T<sub>0</sub>, T<sub>X</sub>, T<sub>Y</sub>) are shown in the sketches below. The upper values in the T<sub>X</sub> and T<sub>Y</sub> columns apply to one slide unit, and the lower values apply to two slide units in close contact.  
<sup>(3)</sup>: LWHT8...SL, LWHT10...SL and LWHT12...SL can also be mounted from the lower side.  
 Remark 1: The mark ☆ indicates that interchangeable specification products are available.  
 2: The appended track rail mounting bolts are hexagon socket head bolts of JIS B 1176 or equivalent.  
 For stainless steel type Linear Way H, stainless steel bolts are appended.  
 3: For grease nipple and oil hole specifications, see page 99.  
 4: LWHT8...SL and LWHT10...SL are provided with an oil hole.

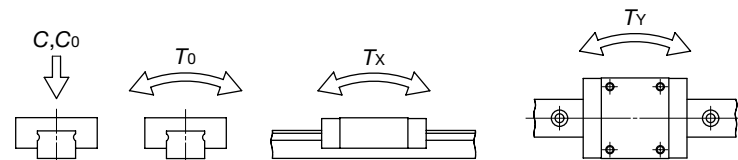

Example of identification number of assembled set (For details, see "Identification number and specification".)

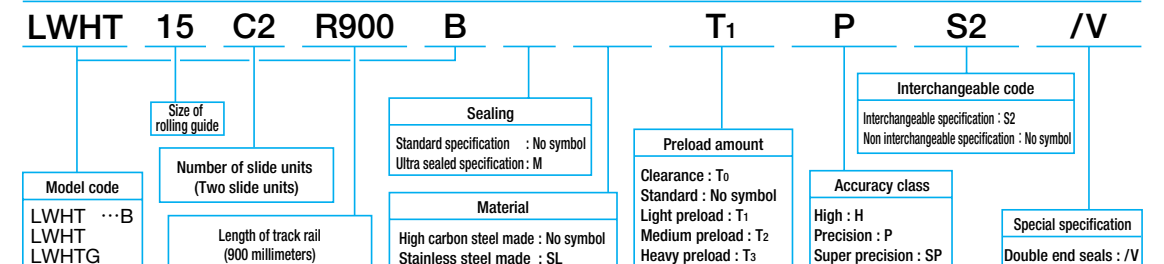

# IKO Linear Way H : Flange type

Flange type mounted from top  
**LWHT ...B**  
**LWHTG**  
**LWHT ...SL** (Stainless steel made)  
**LWHT ...M** (Ultra sealed type)

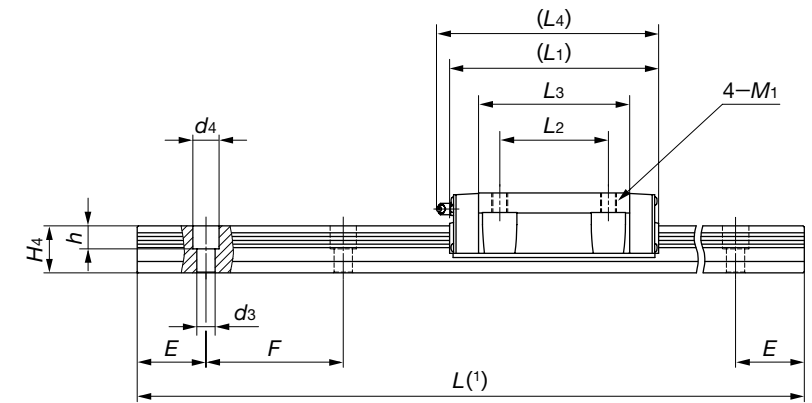
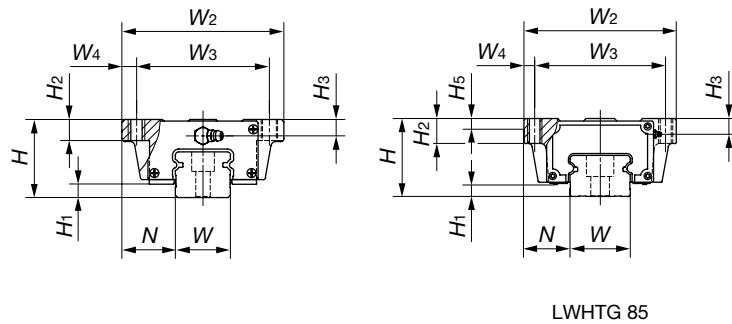

Model number	Interchangeable	Mass (Ref.)		Dimensions of assembly mm			Dimensions of slide unit mm							
		Slide unit kg	Track rail kg/m	H	H <sub>1</sub>	N	W <sub>2</sub>	W <sub>3</sub>	W <sub>4</sub>	L <sub>1</sub>	L <sub>2</sub>	L <sub>3</sub>	L <sub>4</sub>	M <sub>1</sub>
LWHT 30...B	☆	1.28	4.82	42	7	31	90	72	9	113	52	80.6	124	M 10
LWHT 30...SL	☆													
LWHT 30...M														
LWHTG 30	☆	1.69								139		106.6	150	
LWHT 35...B	☆	1.79	6.85	48	8	33	100	82	9	123	62	86.2	135	M 10
LWHT 35...M														
LWHTG 35	☆													
LWHT 45...B	☆	3.17	10.7	60	10	37.5	120	100	10	147	80	103.4	158	M 12
LWHT 45...M														
LWHTG 45	☆													
LWHT 55...B	☆	5.30	15.5	70	13	43.5	140	116	12	183	95	132	194	M 14
LWHTG 55	☆													
LWHT 65...B	☆													
LWHTG 65	☆	17.6								303		238.8	313	
LWHTG 85		25.9	34.6	110	16	65	215	185	15	318	140	240	—	M 20

Dimensions of track rail mm			Mounting bolt for track rail mm	Basic dynamic load rating <sup>(2)</sup>	Basic static load rating <sup>(2)</sup>	Static moment rating <sup>(2)</sup>									
H <sub>2</sub>	H <sub>3</sub>	H <sub>5</sub>				C	C <sub>0</sub>	T <sub>0</sub>	T <sub>X</sub>	T <sub>Y</sub>					
W	H <sub>4</sub>	d <sub>3</sub>	d <sub>4</sub>	h	E	F	Bolt size × length	N	N	N·m	N·m	N·m			
10	8	—	28	25	9	14	12	40	80	M 8×28	35 400	40 700	623	536 2 820	536 2 820
											42 700	53 200	814	894 4 460	894 4 460
13	10	—	34	28	9	14	12	40	80	M 8×28	48 700	53 700	823	631 3 480	579 3 190
											59 500	71 600	1 100	1 090 5 570	1 000 5 110
15	13	—	45	34	14	20	17	52.5	105	M12×35	74 600	80 200	1 610	1 150 6 190	1 060 5 690
											95 200	114 000	2 280	2 240 11 100	2 050 10 200
17	14	—	53	41	16	23	20	60	120	M14×45	113 000	121 000	2 870	2 210 11 600	2 030 10 600
											142 000	168 000	3 970	4 120 20 200	3 780 18 500
23	20	—	63	48	18	26	22	75	150	M16×50	176 000	184 000	5 180	4 130 22 000	3 790 20 200
											229 000	269 000	7 560	8 530 41 500	7 810 38 100
35	22	15	85	58	26	39	30	90	180	M24×60	374 000	384 000	11 900	11 100 55 100	11 100 55 300

Note<sup>(1)</sup> : Track rail lengths are shown in Table 11.1 on page B-90, Table 11.2 on page B-91 and Table 11.3 on page B-92.  
<sup>(2)</sup> : The directions of basic dynamic load rating (C), basic static load rating (C<sub>0</sub>) and static moment rating (T<sub>0</sub>, T<sub>X</sub>, T<sub>Y</sub>) are shown in the sketches below. The upper values in the T<sub>X</sub> and T<sub>Y</sub> columns apply to one slide unit, and the lower values apply to two slide units in close contact.  
 Remark 1 : The mark ☆ indicates that interchangeable specification products are available.  
 2 : The appended track rail mounting bolts are hexagon socket head bolts of JIS B 1176 or equivalent.  
 For stainless steel type Linear Way H, stainless steel bolts are appended.  
 3 : For grease nipple specifications, see page 99.

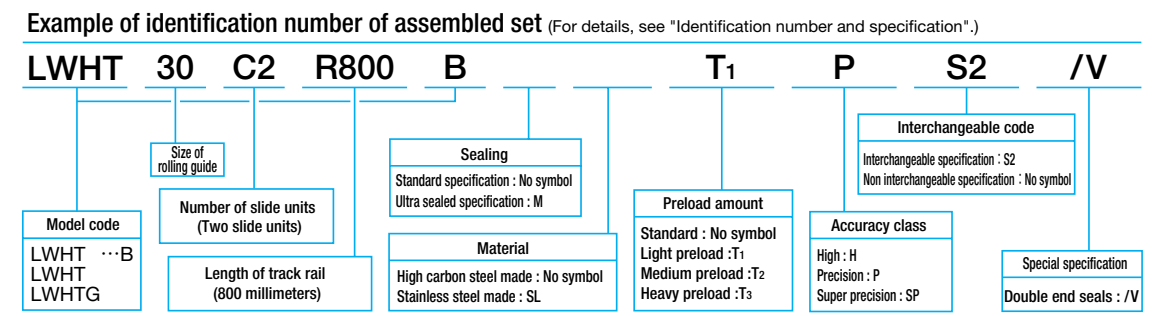
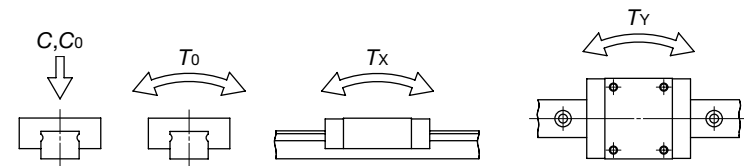

Block type mounted from top

- LWHD ...B
- LWHDG
- LWHDG...SL (Stainless steel made)
- LWHD ...SL (Stainless steel made)
- LWHDG...SL (Stainless steel made)
- LWHD ...M (Ultra sealed type)

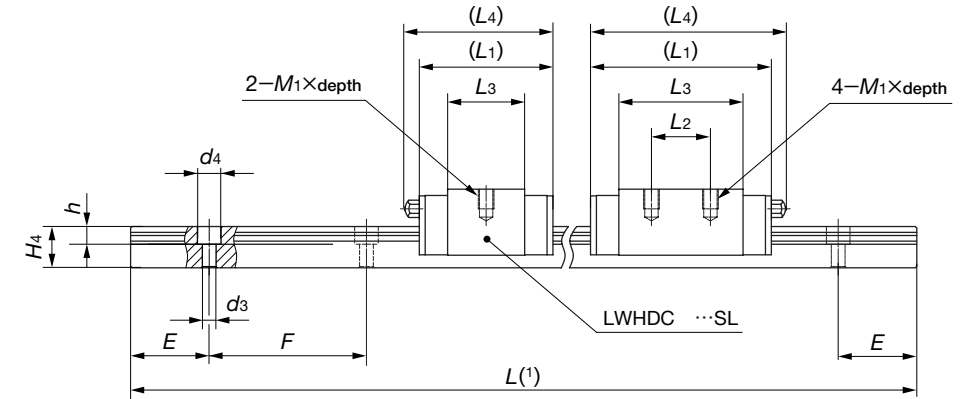
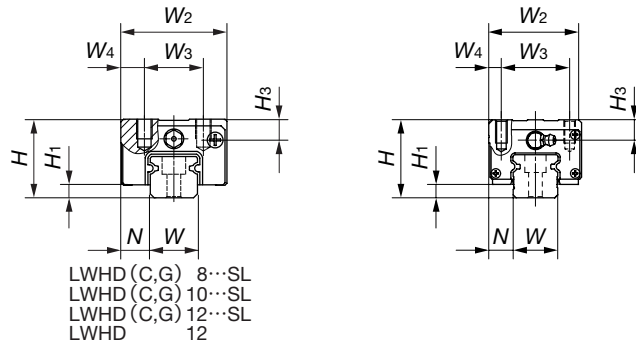

Model number	Interchangeable	Mass (Ref.)		Dimensions of assembly mm			Dimensions of slide unit mm							
		Slide unit kg	Track rail kg/m	H	H <sub>1</sub>	N	W <sub>2</sub>	W <sub>3</sub>	W <sub>4</sub>	L <sub>1</sub>	L <sub>2</sub>	L <sub>3</sub>	L <sub>4</sub>	M <sub>1</sub> × depth
LWHDG 8...SL	☆	0.008	0.32	11	2.1	4	16	10	3	18	—	9.0	—	M2 × 2.5
LWHD 8...SL	☆	0.013								24	10	15.3		
LWHDG 8...SL	☆	0.018								30.5	21.7			
LWHDG 10...SL	☆	0.018	0.47	13	2.4	5	20	13	3.5	24	—	13.4	—	M2.6 × 3
LWHD 10...SL	☆	0.027								32	12	21.4		
LWHDG 10...SL	☆	0.036								40	29.4			
LWHDG 12...SL	☆	0.058	0.86	20	3.2	7.5	27	15	6	34	—	19.6	38	M4 × 5
LWHD 12	☆	0.091								46	15	31.6	50	
LWHD 12...SL	☆	0.118								58	43.6	62		
LWHDG 12...SL	☆	0.118	1.47	28	4.5	9.5	34	26	4	66	26	44.6	69	M4 × 10
LWHD 15...B	☆	0.23								95	35	64.7	106	
LWHD 15...M	☆	0.65								118	50	87.4	129	
LWHD 25...B	☆	0.80	3.50	40	6.5	12.5	48	35	6.5	95	35	64.7	106	M6 × 12
LWHD 25...M	☆									118	50	87.4	129	
LWHDG 25	☆	0.80												

H <sub>3</sub>	Dimensions of track rail mm							Mounting bolt for track rail mm Bolt size × length	Basic dynamic load rating <sup>(2)</sup>		Basic static load rating <sup>(2)</sup>		Static moment rating <sup>(2)</sup>		
	W	H <sub>4</sub>	d <sub>3</sub>	d <sub>4</sub>	h	E	F		C	C <sub>0</sub>	T <sub>0</sub>	T <sub>x</sub>	T <sub>y</sub>		
	N	N	N·m	N·m	N·m	N·m	N·m								
3	8	6	2.4	4.2	2.3	10	20	M2 × 8	1 050	1 270	5.3	2.2	1.8		
									15.5	13.0	8.8	5.5	4.7		
									32.0	26.9	12.3	10.4	8.8		
3.5	10	7	3.5	6	3.5	12.5	25	M3 × 8	1 910	2 970	12.2	5.8	4.8		
									1 920	2 350	19.2	37.1	31.2		
									2 640	3 700	26.2	13.3	11.1		
5	12	10.5	3.5	6	4.5	20	40	M3 × 12	3 280	5 050	26.2	23.8	20.0		
									4 560	5 300	32.8	123	103		
									6 260	8 330	51.6	19.4	16.3		
8.5	15	15	4.5	8	6	30	60	M4 × 16	7 780	11 400	70.4	80.4	67.5		
									11 600	13 400	112	399	335		
									25 200	28 800	362	95.6	95.6		
10.5	23	22	7	11	9	30	60	M6 × 22	25 200	28 800	362	309	309		
									30 800	38 300	483	1 690	1 690		
												533	533		
												2 740	2 740		

Note(1) : Track rail lengths are shown in Table 11.1 on page B-90, Table 11.2 on page B-91 and Table 11.3 on page B-92.  
 (2) : The directions of basic dynamic load rating (C), basic static load rating (C<sub>0</sub>) and static moment rating (T<sub>0</sub>, T<sub>x</sub>, T<sub>y</sub>) are shown in the sketches below. The upper values in the T<sub>x</sub> and T<sub>y</sub> columns apply to one slide unit, and the lower values apply to two slide units in close contact.  
 Remark 1 : The mark ☆ indicates that interchangeable specification products are available.  
 2 : The appended track rail mounting bolts are hexagon socket head bolts of JIS B 1176 or equivalent.  
 For stainless steel type Linear Way H, stainless steel bolts are appended.  
 3 : For grease nipple and oil hole specifications, see page 99.  
 4 : LWHD8...SL and LWHD10...SL are provided with an oil hole.

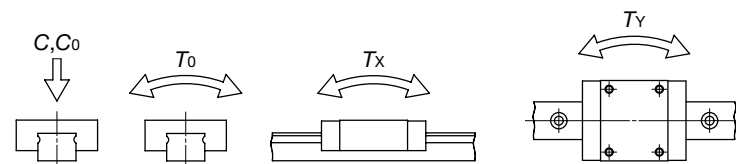

Example of identification number of assembled set (For details, see "Identification number and specification".)

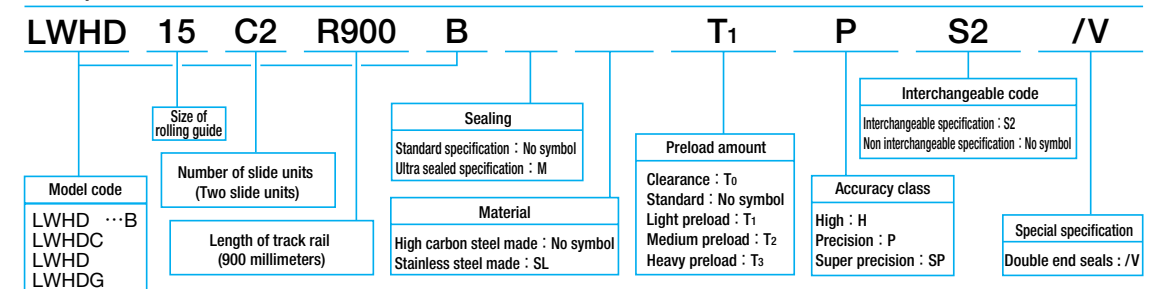

Block type mounted from top  
**LWHD ...B**  
**LWHDG**  
**LWHD ...M** (Ultra sealed type)

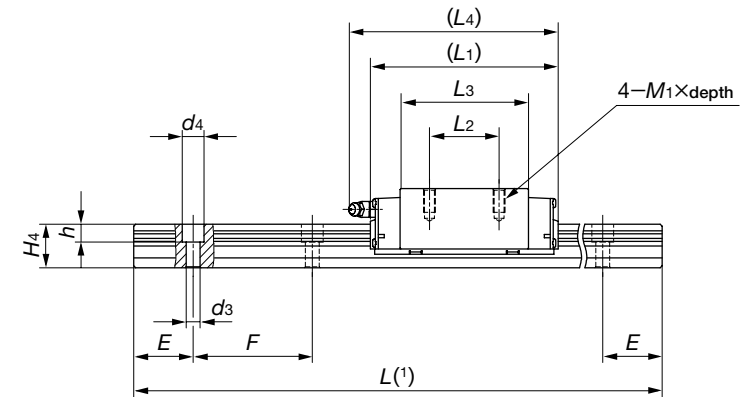
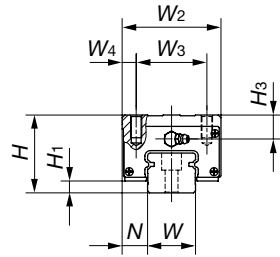

Model number	Interchangeable	Mass (Ref.)		Dimensions of assembly mm			Dimensions of slide unit mm							
		Slide unit kg	Track rail kg/m	H	H <sub>1</sub>	N	W <sub>2</sub>	W <sub>3</sub>	W <sub>4</sub>	L <sub>1</sub>	L <sub>2</sub>	L <sub>3</sub>	L <sub>4</sub>	M <sub>1</sub> × depth
LWHD 30...B	☆	1.12	4.82	45	7	16	60	40	10	113	40	80.6	124	M8 × 16
LWHD 30...M	☆									139	60	106.6	150	
LWHDG 30	☆	1.44	6.85	55	8	18	70	50	10	123	50	86.2	135	M8 × 16
LWHD 35...B	☆	1.74								151	72	114	163	
LWHD 35...M	☆	2.26	10.7	70	10	20.5	86	60	13	147	60	103.4	158	M10 × 20
LWHDG 35	☆	4.57								190	80	146.6	201	
LWHD 45...B	☆	5.36	15.5	80	13	23.5	100	75	12.5	183	75	132	194	M12 × 25
LWHD 45...M	☆	7.20								235	95	183.6	246	
LWHDG 45	☆	9.80	22.2	90	14	31.5	126	76	25	229	70	164	239	M16 × 30
LWHD 55...B	☆	14.3								303	120	238.8	313	
LWHDG 55	☆	7.20	22.2	90	14	31.5	126	76	25	229	70	164	239	M16 × 30
LWHD 65...B	☆	14.3								303	120	238.8	313	
LWHDG 65	☆	14.3	22.2	90	14	31.5	126	76	25	229	70	164	239	M16 × 30
LWHD 65...M	☆	14.3								303	120	238.8	313	

H <sub>3</sub>	Dimensions of track rail mm								Mounting bolt for track rail mm Bolt size × length	Basic dynamic load rating <sup>(2)</sup>	Basic static load rating <sup>(2)</sup>	Static moment rating <sup>(2)</sup>		
	W	H <sub>4</sub>	d <sub>3</sub>	d <sub>4</sub>	h	E	F	C N		C <sub>0</sub> N	T <sub>0</sub> N·m	T <sub>X</sub> N·m	T <sub>Y</sub> N·m	
11	28	25	9	14	12	40	80	M8 × 28	35 400	40 700	623	536 2 820	536 2 820	
									42 700	53 200	814	894 4 460	894 4 460	
17	34	28	9	14	12	40	80	M8 × 28	48 700	53 700	823	631 3 480	579 3 190	
									59 500	71 600	1 100	1 090 5 570	1 000 5 110	
23	45	34	14	20	17	52.5	105	M12 × 35	74 600	80 200	1 610	1 150 6 190	1 060 5 690	
									95 200	114 000	2 280	2 240 11 100	2 050 10 200	
24	53	41	16	23	20	60	120	M14 × 45	113 000	121 000	2 870	2 210 11 600	2 030 10 600	
									142 000	168 000	3 970	4 120 20 200	3 790 18 500	
20	63	48	18	26	22	75	150	M16 × 50	176 000	184 000	5 180	4 130 22 000	3 790 20 200	
									229 000	269 000	7 560	8 530 41 500	7 810 38 100	

Note<sup>(1)</sup>: Track rail lengths are shown in Table 11.1 on page B-90, Table 11.2 on page B-91 and Table 11.3 on page B-92.  
<sup>(2)</sup>: The directions of basic dynamic load rating (C), basic static load rating (C<sub>0</sub>) and static moment rating (T<sub>0</sub>, T<sub>X</sub>, T<sub>Y</sub>) are shown in the sketches below. The upper values in the T<sub>X</sub> and T<sub>Y</sub> columns apply to one slide unit, and the lower values apply to two slide units in close contact.  
 Remark 1: The mark ☆ indicates that interchangeable specification products are available.  
 2: The appended track rail mounting bolts are hexagon socket head bolts of JIS B 1176 or equivalent.  
 For stainless steel type Linear Way H, stainless steel bolts are appended.  
 3: For grease nipple specifications, see page 99.

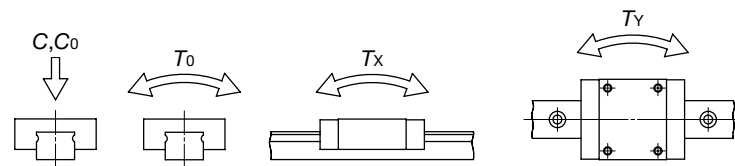

Example of identification number of assembled set (For details, see "Identification number and specification".)

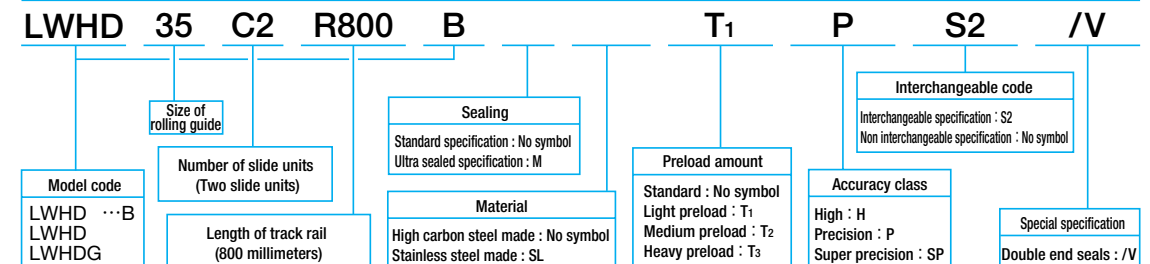

# IKO Linear Way H : Compact block type

Compact block type mounted from top  
**LWHS ...B**  
**LWHS G**  
**LWHS ...SL** (Stainless steel made)  
**LWHS ...M** (Ultra sealed type)

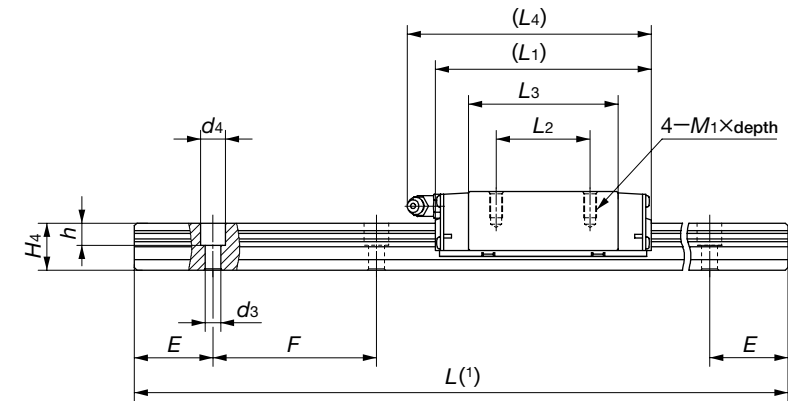
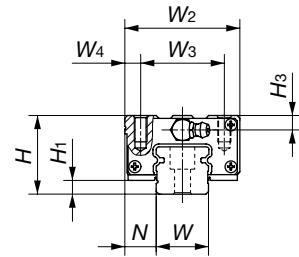

Model number	Interchangeable	Mass (Ref.)		Dimensions of assembly mm			Dimensions of slide unit mm							
		Slide unit kg	Track rail kg/m	H	H <sub>1</sub>	N	W <sub>2</sub>	W <sub>3</sub>	W <sub>4</sub>	L <sub>1</sub>	L <sub>2</sub>	L <sub>3</sub>	L <sub>4</sub>	M <sub>1</sub> ×depth
LWHS 15...B	☆	0.18	1.47	24	4.5	9.5	34	26	4	66	26	44.6	69	M4×8
LWHS 15...SL	☆													
LWHS 15...M														
LWHS 20...B	☆	0.36	2.56	30	5	12	44	32	6	83	36	57.2	95	M5×10
LWHS 20...SL	☆													
LWHS 20...M														
LWHS G 20	☆	0.53								112	50	86	124	
LWHS 25...B	☆	0.55	3.50	36	6.5	12.5	48	35	6.5	95	35	64.7	106	M6×12
LWHS 25...SL	☆													
LWHS 25...M														
LWHS G 25	☆	0.67								118	50	87.4	129	
LWHS 30...B	☆	1.00	4.82	42	7	16	60	40	10	113	40	80.6	124	M8×16
LWHS 30...SL	☆													
LWHS 30...M														
LWHS G 30	☆	1.29								139	60	106.6	150	

H <sub>3</sub>	Dimensions of track rail mm							Mounting bolt for track rail mm Bolt size × length	Basic dynamic load rating <sup>(2)</sup> C N	Basic static load rating <sup>(2)</sup> C <sub>0</sub> N	Static moment rating <sup>(2)</sup>		
	W	H <sub>4</sub>	d <sub>3</sub>	d <sub>4</sub>	h	E	F				T <sub>0</sub> N·m	T <sub>X</sub> N·m	T <sub>Y</sub> N·m
4.5	15	15	4.5	8	6	30	60	M4×16	11 600	13 400	112	95.6 556	95.6 556
5.5	20	18	6	9.5	8.5	30	60	M5×18	18 100	21 100	232	195 1 090	195 1 090
									24 100	31 700	349	421 2 140	421 2 140
6.5	23	22	7	11	9	30	60	M6×22	25 200	28 800	362	309 1 690	309 1 690
									30 800	38 300	483	533 2 740	533 2 740
8	28	25	9	14	12	40	80	M8×28	35 400	40 700	623	536 2 820	536 2 820
									42 700	53 200	814	894 4 460	894 4 460

Note<sup>(1)</sup> : Track rail lengths are shown in Table 11.1 on page B-90, Table 11.2 on page B-91 and Table 11.3 on page B-92.  
<sup>(2)</sup> : The directions of basic dynamic load rating (C), basic static load rating (C<sub>0</sub>) and static moment rating (T<sub>0</sub>, T<sub>X</sub>, T<sub>Y</sub>) are shown in the sketches below. The upper values in the T<sub>X</sub> and T<sub>Y</sub> columns apply to one slide unit, and the lower values apply to two slide units in close contact.  
 Remark 1 : The mark ☆ indicates that interchangeable specification products are available.  
 2 : The appended track rail mounting bolts are hexagon socket head bolts of JIS B 1176 or equivalent.  
 For stainless steel type Linear Way H, stainless steel bolts are appended.  
 3 : For grease nipple specifications, see page 99.

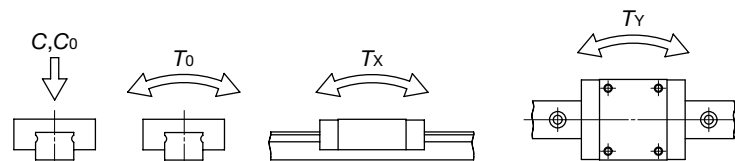

Example of identification number of assembled set (For details, see "Identification number and specification".)

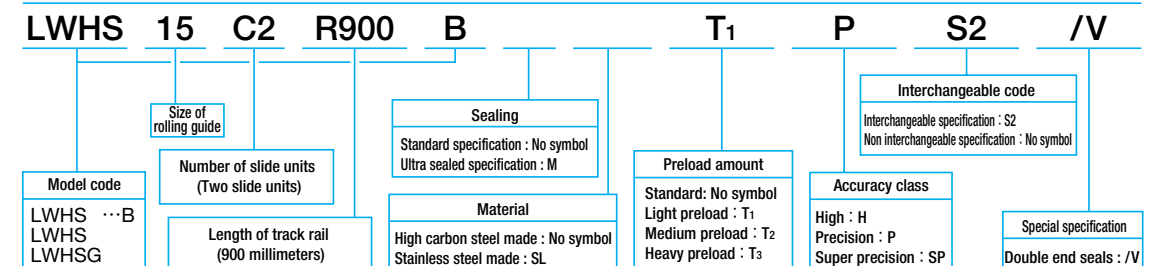



# IKO Linear Way H : Side mounting type

Side mounting type  
**LWHY**

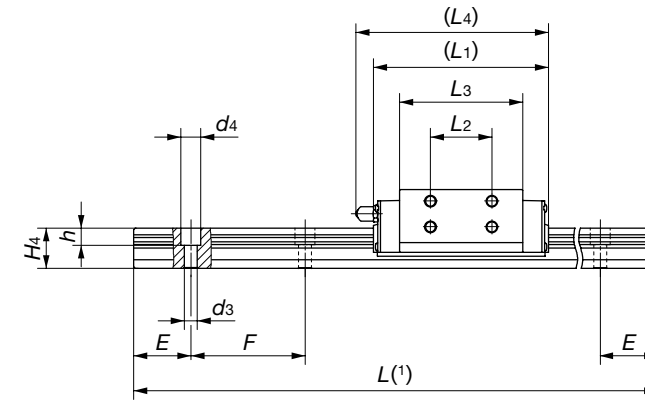
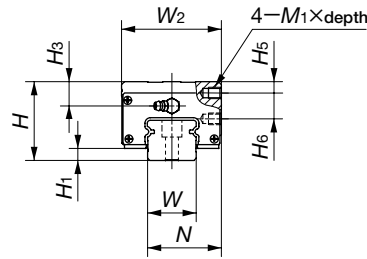

Model number	Mass (Ref.)		Dimensions of assembly mm			Dimensions of slide unit mm						
	Slide unit kg	Track rail kg/m	H	H <sub>1</sub>	N	W <sub>2</sub>	L <sub>1</sub>	L <sub>2</sub>	L <sub>3</sub>	L <sub>4</sub>	M <sub>1</sub> ×depth	H <sub>3</sub>
<b>LWHY 15</b>	0.23	1.47	28	4.5	24.3	34	66	18	44.6	69	M 4× 4	8.5
<b>LWHY 20</b>	0.36	2.56	30	5	31.5	43.7	83	25	57.2	95	M 5× 5	5.5
<b>LWHY 25</b>	0.65	3.50	40	6.5	35	47.7	95	30	64.7	106	M 6× 6	10.5
<b>LWHY 30</b>	1.12	4.82	45	7	43.5	59.7	113	40	80.6	124	M 6× 7	11
<b>LWHY 35</b>	1.74	6.85	55	8	51.5	69.7	123	43	86.2	135	M 8× 9	17
<b>LWHY 45</b>	3.30	10.7	70	10	65	85.7	147	55	103.4	158	M10×11	23
<b>LWHY 55</b>	5.36	15.5	80	13	76	99.7	183	70	132	194	M12×13	24
<b>LWHY 65</b>	9.80	22.2	90	14	94.5	126	229	85	164	239	M16×16	20

		Dimensions of track rail mm							Mounting bolt for track rail mm	Basic dynamic load rating <sup>(2)</sup>	Basic static load rating <sup>(2)</sup>	Static moment rating <sup>(2)</sup>		
H <sub>5</sub>	H <sub>6</sub>	W	H <sub>4</sub>	d <sub>3</sub>	d <sub>4</sub>	h	E	F	Bolt size × length	C N	C <sub>0</sub> N	T <sub>0</sub> N·m	T <sub>X</sub> N·m	T <sub>Y</sub> N·m
4	9	15	15	4.5	8	6	30	60	M 4×16	9 360	13 900	116	99.2 577	99.2 577
4	10	20	18	6	9.5	8.5	30	60	M 5×18	14 500	21 900	241	202 1 130	202 1 130
6	12	23	22	7	11	9	30	60	M 6×22	20 100	29 800	376	320 1 750	320 1 750
8	14	28	25	9	14	12	40	80	M 8×28	28 100	42 200	646	556 2 930	556 2 930
8	18	34	28	9	14	12	40	80	M 8×28	31 200	43 500	878	665 3 600	601 3 310
10	22	45	34	14	20	17	52.5	105	M12×35	47 600	65 000	1 720	1 200 6 420	1 100 5 900
12	25	53	41	16	23	20	60	120	M14×45	71 200	98 300	3 050	2 300 12 000	2 110 11 000
12	30	63	48	18	26	22	75	150	M16×50	110 000	149 000	5 510	4 280 22 800	3 930 21 000

Note<sup>(1)</sup> : Track rail lengths are shown in Table 11.1 on page B-90.

<sup>(2)</sup> : The directions of basic dynamic load rating (C), basic static load rating (C<sub>0</sub>) and static moment rating (T<sub>0</sub>, T<sub>X</sub>, T<sub>Y</sub>) are shown in the sketches below. The upper values in the T<sub>X</sub> and T<sub>Y</sub> columns apply to one slide unit, and the lower values apply to two slide units in close contact.

Remark 1 : The appended track rail mounting bolts are hexagon socket head bolts of JIS B 1176 or equivalent.

2 : For grease nipple specifications, see page 99.

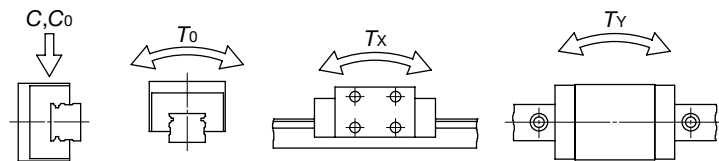

Example of identification number of assembled set (For details, see "Identification number and specification".)

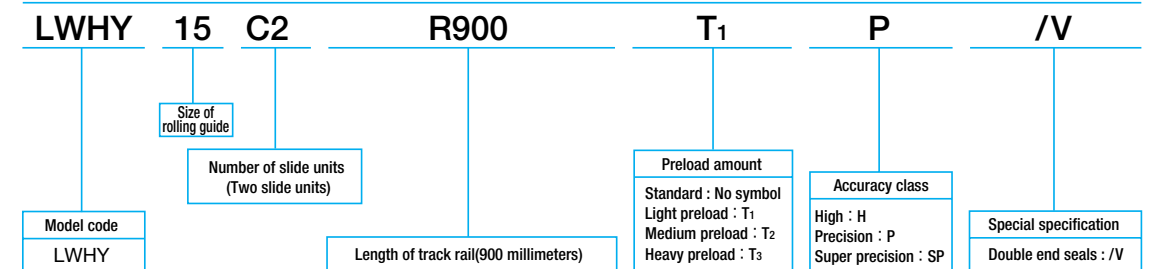

# Linear Way F

## LWFH/LWFF/LWFS

**IKO** Linear Way F is a linear motion rolling guide, featuring a wide track rail along which a highly rigid slide unit performs endless linear motion. A large number of large diameter steel balls are incorporated in two rows and in four point contact with the raceways, so stable high accuracy and rigidity can be obtained in operations even under fluctuating loads with changing direction and magnitude or complex loads. Being a wide rail type, it can support a large moment load acting around the axial direction, and it is also suitable for single row rail arrangement.

### Wide structure

Because the distance between the load points under a moment load is large, this guide has high load capacity under moment load and complex load.

### Flange type and block type

Three types of slide units are available; two flange types of different dimension series and one block type with a narrower width.

### Stainless steel type

The stainless steel type has excellent corrosion resistance and is the most suitable for machines and equipment used in clean environments, for example, medical equipment, and semiconductor and FPD manufacturing equipment.

### Interchangeable

Linear Way F includes interchangeable specification products. The dimensions of slide units and track rails of this specification are individually controlled, so that the slide units and track rails can be combined, added or exchanged freely.

### Good load balance

Owing to the simple two row design, large diameter steel balls are incorporated to receive loads in all directions with high load ratings.

### High rigidity

Steel balls are arranged in four point contact with the raceways in a highly rigid casing, and they are tightly held in their position without play. So high rigidity in all directions is obtained.

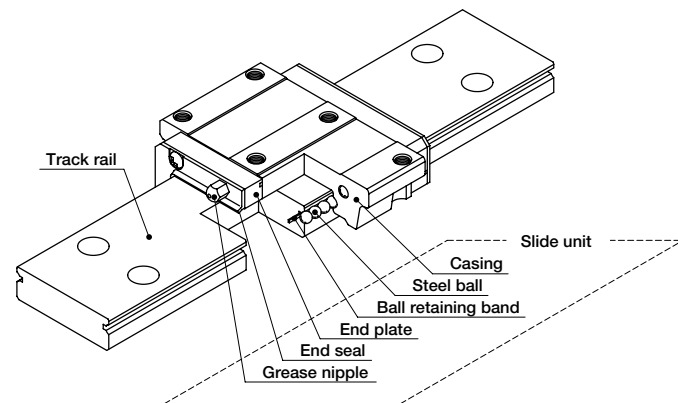

Structure of Linear Way F

U.S. PATENT No. 6,176,617  
No. 5,967,667  
No. 4,505,522

## Linear Way F series

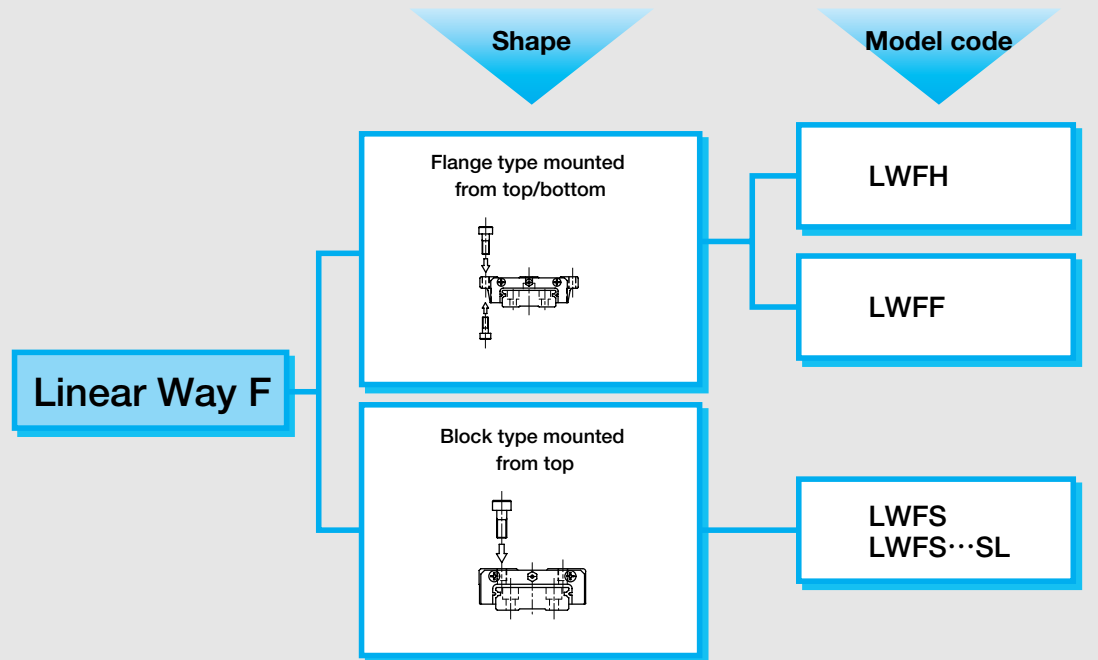

Remark : Models with "SL" are stainless steel type.

## ● Identification number and specification

The specification of Linear Way F is indicated by the identification number, consisting of a model code, a size, a part code, a material symbol, a preload symbol, a classification symbol, an interchangeable code and any supplemental codes. For details of each specification, see page 78.

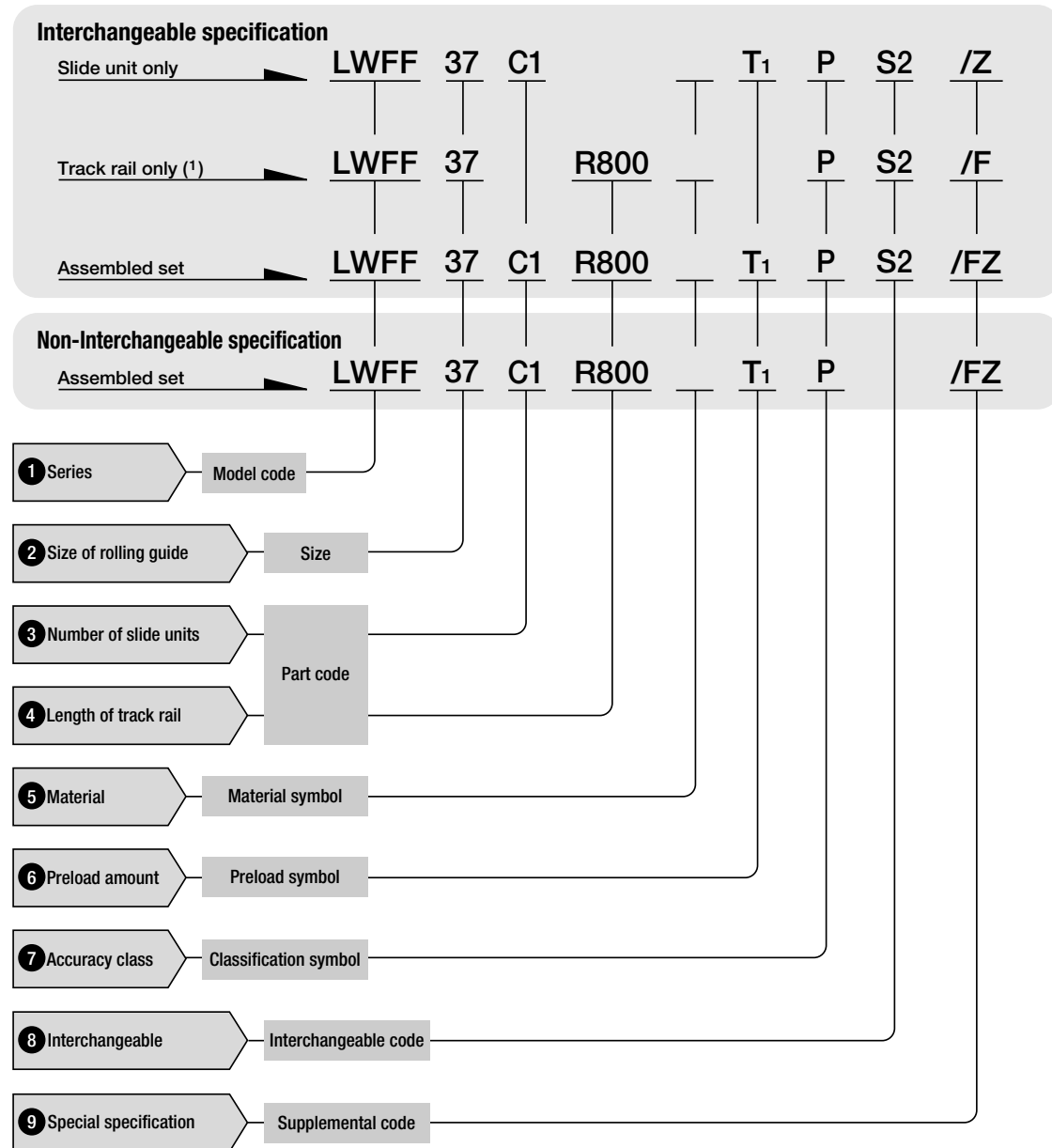

Note(1) : For the model code of a single track rail of interchangeable specification of LWFS, indicate "LWFF".  
Track rail of interchangeable LWFS → Model code LWFF (Ex: LWFF37R800PS2/F)

**1 Series**

Flange type mounted from top/bottom : LWFFH  
LWFF

Block type mounted from top : LWFS

**2 Size of rolling guide**

For available models and sizes of side units, see Table 1.

Table 1 Models and sizes of Linear Way F

Size	Flange type		Block type	
	High carbon steel made		High carbon steel made	Stainless steel made
	LWFFH	LWFF	LWFS	LWFS...SL
33	—	☆	☆	☆
37	—	☆	☆	☆
40	☆	—	—	—
42	—	☆	—	☆
60	☆	—	—	—
69	—	☆	—	—
90	☆	—	—	—

Remark : The mark ☆ indicates that interchangeable specification products are available.

**3 Number of slide units**

Assembled set : C○  
Slide unit only : C1

For an assembled set, indicate the number of slide units assembled on one track rail. For a slide unit, only "C1" can be indicated.

**4 Length of track rail**

Assembled set : R○  
Track rail only : R○

Indicate the length of track rail in mm. For standard and maximum lengths, see "Track rail length" on page B-122.

**5 Material**

High carbon steel made : No symbol  
Stainless steel made : SL

For applicable material types, see Table 1.

**6** Preload amount

Standard : No symbol  
 Light preload : T1  
 Medium preload : T2

Specify this item for an assembled set or a single slide unit. For applicable amount, see Table 2. For details of preload amount, see page 86.

Table 2 Applicable preload types

Size	Preload type (Symbol)		
	Standard (No symbol)	Light preload (T1)	Medium preload (T2)
33	☆	☆	○
37	☆	☆	○
40	☆	☆	○
42	☆	☆	○
60	☆	☆	○
69	☆	☆	○
90	☆	☆	○

Remark : The mark ☆ indicates that it is also applicable to interchangeable specification products.

**7** Accuracy class

High : H  
 Precision : P  
 Super precision : SP

For applicable accuracy, see Table 3. For the interchangeable specification, combine slide units and track rails of the same class. For details of accuracy, see page 81.

Table 3 Applicable accuracy class

Size	Accuracy class (Symbol)		
	High (H)	Precision (P)	Super precision (SP)
33	☆	☆	○
37	☆	☆	○
40	☆	☆	○
42	☆	☆	○
60	☆	☆	○
69	☆	☆	○
90	☆	☆	○

Remark : The mark ☆ indicates that it is also applicable to interchangeable specification products.

**8** Interchangeable code

Select group 1 : S1  
 Select group 2 : S2

Specify this item for interchangeable specification products. Combine track rails and slide units with the same interchangeable code. Performance and accuracy of "S1" group and "S2" group are the same.

**9** Special specification

For applicable special specifications, see Tables 4.1 and 4.2. When several special specifications are required, see Table 5. For details of special specifications, see page 88.

Table 4.1 Special specifications of LWFH

Special specification	Supplemental code	Assembled set	Track rail	Slide unit	Dimension
Butt-jointing track rail	A	○	—	—	
Chamfered reference surface	C	○ (1)	—	—	See Fig. 1.
Opposite reference surfaces arrangement	D	☆	—	—	
Specified rail mounting hole positions	E	☆	☆	—	
Caps for rail mounting holes	F	☆	☆	—	
Inspection sheet	I	○	—	—	
Female threads for bellows	J	☆	☆	☆	See Table 6.1.
Black chrome surface treatment	L	☆	—	—	
Fluorine black chrome surface treatment	LF	☆	—	—	
Supplied without track rail mounting bolt	MN	☆	☆	—	
No end seal	N	☆	—	☆	
Capillary plates	Q	☆	—	☆	See Table 7.
Under seals	U	☆	—	☆	See Table 8.
Matched sets to be used as an assembled group	W	○	—	—	
Specified grease	Y	☆	—	—	
Scrapers	Z	☆	—	☆	See Table 10.

Note(1) : Applicable to size 40 and 60 models.

Remark : In the table, the mark ☆ indicates that it is also applicable to interchangeable specification products.

Table 4.2 Special specifications of LWFF, LWFS

Special specification	Supplemental code	Assembled set	Track rail	Slide unit	Dimension
Butt-jointing track rail	A	○	—	—	
Opposite reference surfaces arrangement	D	☆	—	—	
Specified rail mounting hole positions	E	☆	☆	—	
Caps for rail mounting holes	F	☆	☆	—	
Inspection sheet	I	○	—	—	
Female threads for bellows	J	☆ (1)	☆ (1)	☆	See Table 6.2.
Black chrome surface treatment	L	☆	—	—	
Fluorine black chrome surface treatment	LF	☆	—	—	
Supplied without track rail mounting bolt	MN	☆	☆	—	
No end seal	N	☆	—	☆	
Capillary plates	Q	☆	—	☆	See Table 7.
Under seals	U	☆ (2)	—	☆ (2)	See Table 8.
Double end seals	V	☆	—	☆	See Table 9.
Matched sets to be used as an assembled group	W	○	—	—	
Specified grease	Y	☆	—	—	
Scrapers	Z	☆	—	☆	See Table 10.

Note(1) : Not applicable to stainless steel made interchangeable specification products.

(2) : The H<sub>1</sub> dimension is the same as the dimension of standard products (without under seals).

Remark : In the table, the mark ☆ indicates that it is also applicable to interchangeable specification products.

Table 5 Combination of special specifications

LWFH													LWFF LWFS																		
C	○												D	○																	
D	○	○											E	—	—																
E	—	○	—										F	○	☆	☆															
F	○	○	☆	☆									I	○	○	○	○														
I	○	○	○	○	○								J	○	☆	☆	☆	○													
J	○	○	☆	☆	☆	○							L	○	☆	☆	☆	☆	○												
L	○	○	☆	☆	☆	○	☆						LF	○	☆	☆	☆	☆	○	☆	—										
LF	○	○	☆	☆	☆	○	☆	—					MN	○	☆	☆	☆	☆	○	☆	☆										
MN	○	○	☆	☆	☆	○	☆	☆	☆				N	○	☆	☆	—	○	—	☆	☆	☆									
N	○	○	☆	☆	☆	○	—	☆	☆	☆			Q	○	☆	☆	☆	○	—	☆	☆	☆	☆								
Q	○	○	☆	☆	—	○	—	☆	☆	☆	☆		U	○	☆	☆	☆	○	☆	☆	☆	☆	—	☆							
U	○	○	☆	☆	☆	○	☆	☆	☆	☆	—	☆	V	○	☆	☆	☆	○	★	☆	☆	☆	—	☆							
W	○	○	○	—	○	○	○	○	○	○	○	○	W	○	○	—	○	○	○	○	○	○	○	○							
Y	○	○	☆	☆	☆	○	☆	☆	☆	☆	—	☆	○	Y	○	☆	☆	☆	○	☆	☆	☆	☆	—	☆	☆	○				
Z	○	○	☆	☆	☆	○	—	☆	☆	☆	—	—	☆	○	○	Z	○	☆	☆	☆	○	★	☆	☆	☆	—	—	☆	★	○	☆
	A	C	D	E	F	I	J	L	LF	MN	N	Q	U	W	Y		A	D	E	F	I	J	L	LF	MN	N	Q	U	V	W	Y

Remark 1 : In the table, the mark ☆ indicates that it is also applicable to interchangeable specification products.

2 : In the table, the mark — indicates that this combination cannot be made.

3 : The combinations marked ★ are applicable to non-interchangeable specification products.

For combinations of interchangeable specification products, consult IKO for further information.

4 : When several special specifications are required, arrange the supplemental codes alphabetically.

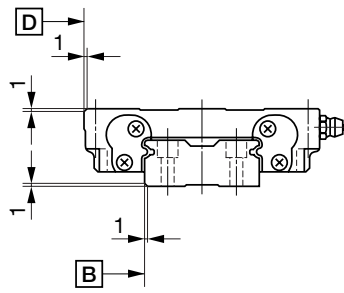
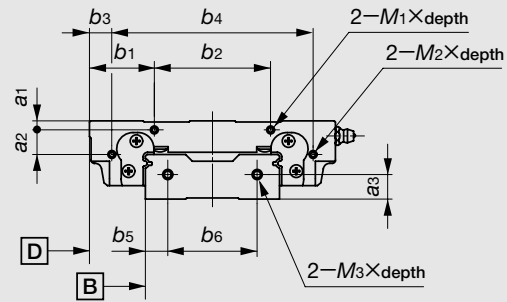

Fig. 1 Chamfers on reference surfaces (Supplemental code /CC)

Table 6.1 Female threads for bellows of LWFH (Supplemental code /J, /JJ)



unit : mm

Model number	Slide unit						Track rail					
	a <sub>1</sub>	a <sub>2</sub>	b <sub>1</sub>	b <sub>2</sub>	b <sub>3</sub>	b <sub>4</sub>	M <sub>1</sub> ×depth	M <sub>2</sub> ×depth	a <sub>3</sub>	b <sub>5</sub>	b <sub>6</sub>	M <sub>3</sub> ×depth
LWFH 40	3	—	23.5	35	—	—	M3×6	—	9	8	24	M3×6
LWFH 60	4	11	29	52	10	90	M3×6	M3×3	11	10	40	M4×8
LWFH 90	6	17	41	80	13	136	M3×5	M3×5	13	15	60	M4×8

Table 6.2 Female threads for bellows of LWFF, LWFS (Supplemental code /J, /JJ)

Size : 33,37,42

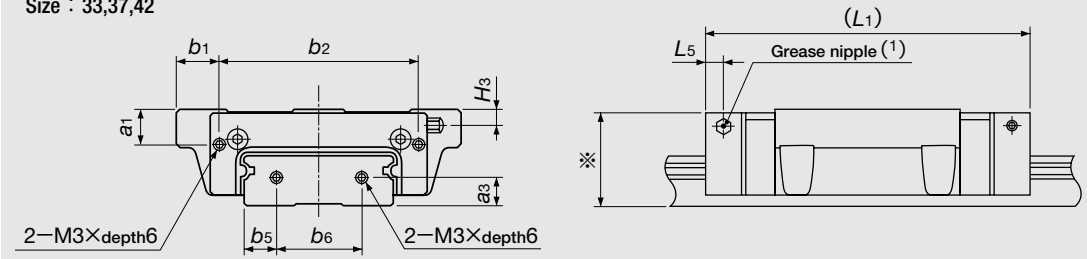

Size : 69

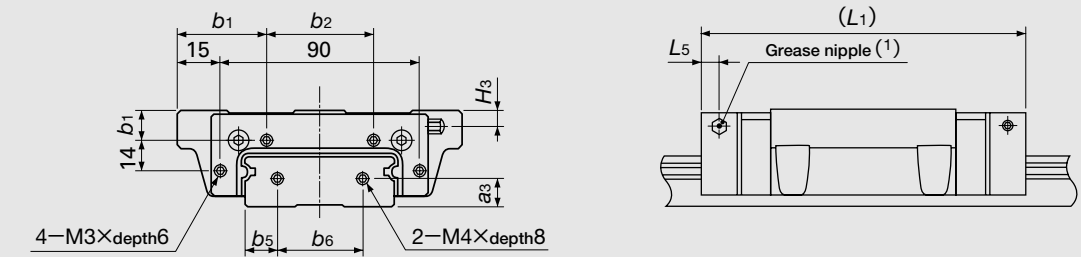

unit : mm

Model number	Slide unit						Track rail		
	a <sub>1</sub>	b <sub>1</sub>	b <sub>2</sub>	L <sub>1</sub> <sup>(2)</sup>	L <sub>5</sub>	H <sub>3</sub>	a <sub>3</sub>	b <sub>5</sub>	b <sub>6</sub>
LWFF 33	4	8.25	43.5	71	5	1	6	7.5	18
LWFS 33		3.25							
LWFF 37	6	10	48	78	5	1	6.5	8.5	20
LWFS 37		3							
LWFF 42	9.5	12	56	92	7	4.5	8	9	24
LWFS 42...SL		3							
LWFF 69	9	35	50	125	7	5	11	14.5	40

Note<sup>(1)</sup> : The specification and mounting position of grease nipple are different from those of the standard specification product.  
For grease nipple specifications, see page 98.

<sup>(2)</sup> : The values for a slide unit with female threads for bellows at both ends are shown.

Remark : For the size 33 and 37 models, the dimension indicated by an asterisk (\*) is higher than the H dimension of Linear Way F.  
For details, consult **I K O** for further information.

Table 7 Slide unit with capillary plates (Supplemental code /Q)

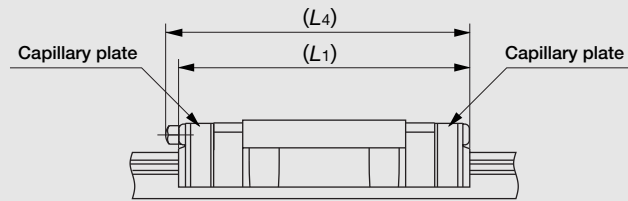

unit : mm

Model number	L1	L4	Model number	L1	L4
LWFH 40	78	—	LWFS 33	64	67
LWFH 60	98	—	LWFS 33...SL		
LWFH 90	131	—	LWFS 37	73	75
LWFF 33	64	67	LWFS 37...SL		
LWFF 37	73	75	LWFS 42...SL	86	99
LWFF 42	86	99			
LWFF 69	121	133			

Table 8 H<sub>1</sub> dimension of slide unit with under seals (Supplemental code /U)

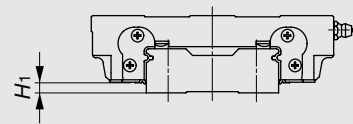

unit : mm

Model number	H <sub>1</sub>
LWFH 40	3
LWFH 60	4
LWFH 90	5

Remark : The H<sub>1</sub> dimension of LWFF and LWFS is the same as that without under seals.

Table 9 LWFF and LWFS slide units with double end seals (Supplemental code /VV)

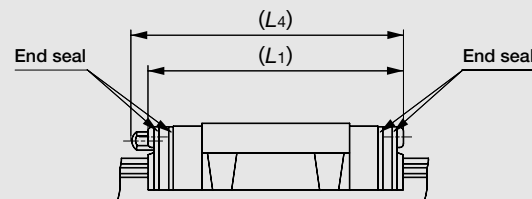

unit : mm

Model number	L1	L4
LWFF 33	61	64
LWFS 33		
LWFF 37	70	74
LWFS 37		
LWFF 42	82	96
LWFF 69	117	130

Remark : The above dimensions are for slide units with double end seals at both ends.

Table 10.1 LWFH slide unit with scrapers (Supplemental code /ZZ)

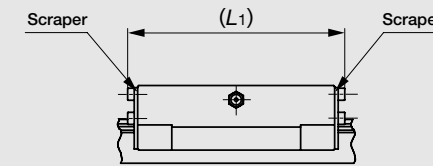

unit : mm

Model number	L1
LWFH 40	79.2
LWFH 60	99.2
LWFH 90	130

Remark : The above values are for slide units with scrapers at both ends.

Table 10.2 LWFF and LWFS slide units with scrapers (Supplemental code /ZZ)

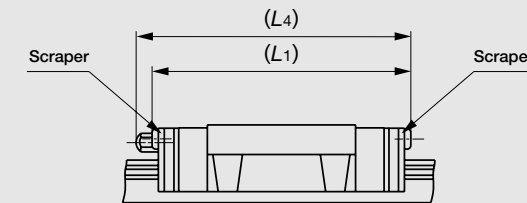

unit : mm

Model number	L1	L4
LWFF 33	62	64
LWFS 33		
LWFF 37	71	75
LWFS 37		
LWFF 42	84	97
LWFF 69	119	131

Remark : The above values are for slide units with scrapers at both ends.

## Track rail length

Standard and maximum lengths of track rails are shown in Table 11.1 and 11.2. Track rails of any length are also available. Simply indicate the required length of track rail in mm in the identification number. For the tolerances of *E* dimension and track rail length, consult **IICO** for further information.

- For track rails longer than the maximum length shown in Table 11.1 and 11.2, butt-jointing track rails are available upon request. In this case, indicate "/A" in the identification number.
- *E* dimensions at both ends are the same and are within the standard range of *E* unless otherwise specified. To change these dimensions, specify the specified rail mounting hole positions "/E" of special specification. For details, see page 91.

Table 11.1 Standard and maximum lengths of high carbon steel track rails

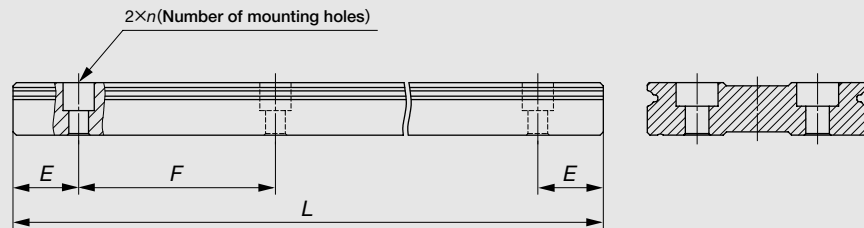

unit : mm

Item	Model number	LWFH 40	LWFH 60	LWFH 90	
Standard length <i>L</i> ( <i>n</i> )		180( 3)	240( 3)	480( 6)	
		240( 4)	480( 5)	640( 8)	
		360( 6)	640( 8)	800(10)	
		480( 8)	800(10)	1 040(13)	
		660(11)	1 040(13)	1 200(15)	
		840(14)		1 520(19)	
Pitch of mounting holes <i>F</i>		60	80	80	
<i>E</i>		30	40	40	
Standard range of <i>E</i> <sup>(1)</sup>	incl.	8	10	10	
	under	38	50	50	
Maximum length <sup>(2)</sup>		1 500	1 520	1 520	
Item	Model number	LWFF 33 LWFS 33	LWFF 37 LWFS 37	LWFF 42	LWFF 69
Standard length <i>L</i> ( <i>n</i> )		120( 3)	150( 3)	180( 3)	320( 4)
		200( 5)	250( 5)	240( 4)	480( 6)
		320( 8)	400( 8)	360( 6)	800(10)
		480(12)	500(10)	480( 8)	1 040(13)
		560(14)	600(12)	660(11)	1 280(16)
			800(16)	840(14)	1 600(20)
Pitch of mounting holes <i>F</i>		40	50	60	80
<i>E</i>		20	25	30	40
Standard range of <i>E</i> <sup>(1)</sup>	incl.	7	7	7	9
	under	27	32	37	49
Maximum length <sup>(2)</sup>		1 600	2 000	1 980	2 000

Note<sup>(1)</sup> : Not applicable to the track rail with female threads for bellows (supplemental code "/J").  
<sup>(2)</sup> : Track rails exceeding the maximum length can also be manufactured. Consult **IICO** for further information.

Table 11.2 Standard and maximum lengths of stainless steel track rails

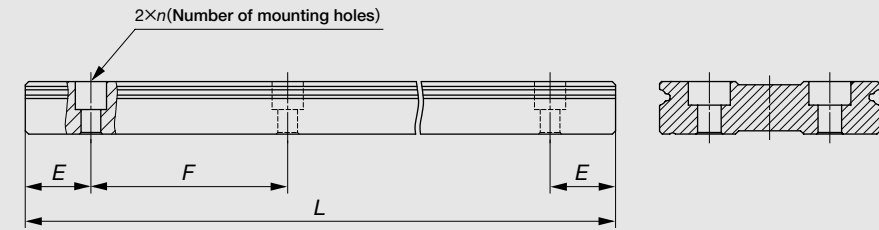

unit : mm

Item	Model number	LWFS 33...SL	LWFS 37...SL	LWFS 42...SL
Standard length <i>L</i> ( <i>n</i> )		120( 3)	150( 3)	180( 3)
		200( 5)	250( 5)	240( 4)
		320( 8)	400( 8)	360( 6)
		480(12)	500(10)	480( 8)
		560(14)	600(12)	660(11)
			800(16)	840(14)
Pitch of mounting holes <i>F</i>		40	50	60
<i>E</i>		20	25	30
Standard range of <i>E</i> <sup>(1)</sup>	incl.	7	7	7
	under	27	32	37
Maximum length <sup>(2)</sup>		1 200	1 200	1 200

Note<sup>(1)</sup> : Not applicable to the track rail with female threads for bellows (supplemental code "/J").  
<sup>(2)</sup> : Track rails exceeding the maximum length can also be manufactured. Consult **IICO** for further information.



**Flange type mounted from top/bottom**  
**LWFH**

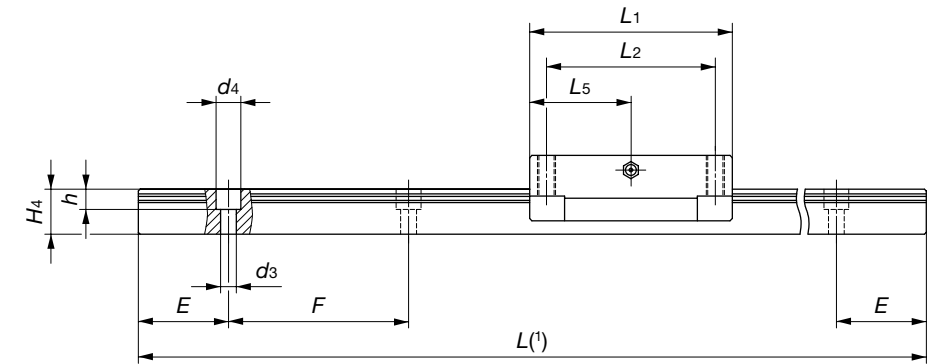
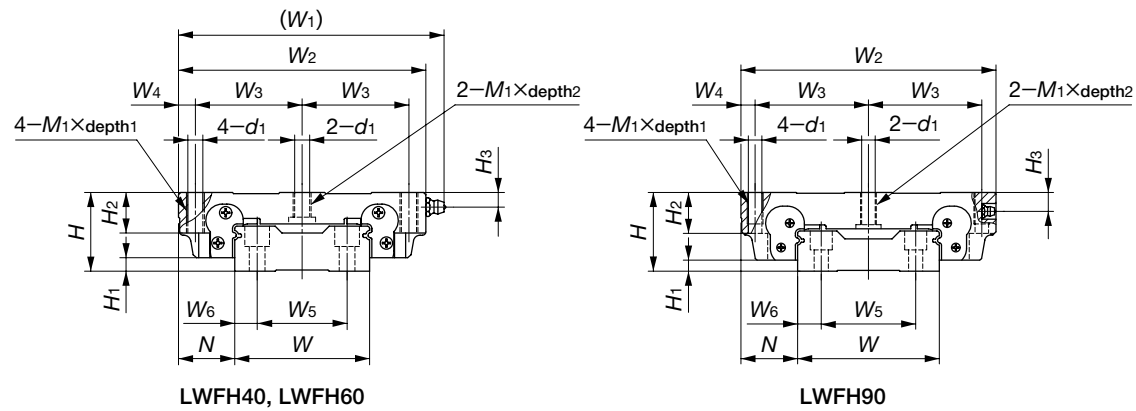

Model number	Interchangeable	Mass (Ref.)		Dimensions of assembly mm			Dimensions of slide unit mm										
		Slide unit kg	Track rail kg/m	H	H <sub>1</sub>	N	W <sub>1</sub>	W <sub>2</sub>	W <sub>3</sub>	W <sub>4</sub>	L <sub>1</sub>	L <sub>2</sub>	L <sub>5</sub>	d <sub>1</sub>	M <sub>1</sub> ×depth <sub>1</sub>	depth <sub>2</sub>	H <sub>2</sub>
LWFH 40	☆	0.58	4.60	27	5	21	92	82	37	4	70	60	27.5	4.3	M 5×14	8	14
LWFH 60	☆	1.29	8.60	35	6	25	120	110	47.5	7.5	90	75	45	6.7	M 8×18	11	18
LWFH 90	☆	4.06	16.5	50	7	36	—	162	72	9	120	100	60	8.6	M10×20	20.5	26

H <sub>3</sub>	Dimensions of track rail mm										Mounting bolt for track rail mm Bolt size x length	Basic dynamic load rating <sup>(2)</sup> C N	Basic static load rating <sup>(2)</sup> C <sub>0</sub> N	Static moment rating <sup>(2)</sup>		
	W	H <sub>4</sub>	W <sub>5</sub>	W <sub>6</sub>	d <sub>3</sub>	d <sub>4</sub>	h	E	F	T <sub>0</sub> N·m				T <sub>x</sub> N·m	T <sub>y</sub> N·m	
6.5	40	16	24	8	4.5	7.2	6	30	60	M4×16	12 600	16 600	280	108 612	99.3 563	
6.5	60	20	40	10	7	11	9	40	80	M6×22	16 100	23 500	600	210 1 090	193 998	
12	90	25.5	60	15	9	14	12	40	80	M8×28	31 600	43 300	1 650	513 2 680	470 2 460	

Note<sup>(1)</sup>: Track rail lengths are shown in Table 11.1 on page B-122.

<sup>(2)</sup>: The directions of basic dynamic load rating (C), basic static load rating (C<sub>0</sub>) and static moment rating (T<sub>0</sub>, T<sub>x</sub>, T<sub>y</sub>) are shown in the sketches below. The upper values in the T<sub>x</sub> and T<sub>y</sub> columns apply to one slide unit, and the lower values apply to two slide units in close contact.

Remark 1: The mark ☆ indicates that interchangeable specification products are available.

2: The appended track rail mounting bolts are hexagon socket head bolts of JIS B 1176 or equivalent.

3: For grease nipple specifications, see page 99.

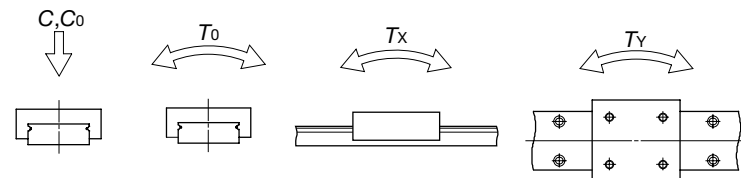

Example of identification number of assembled set (For details, see "Identification number and specification".)

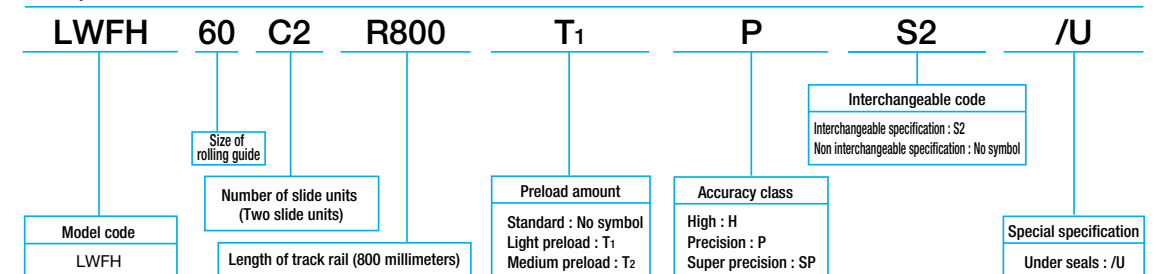

**Flange type mounted from top/bottom**  
**LWFF**

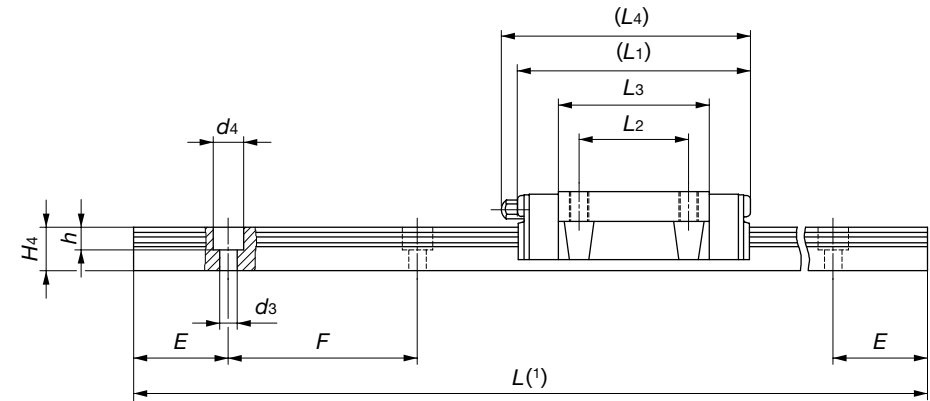
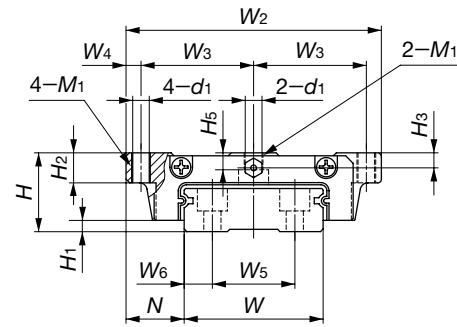

Model number	Interchangeable	Mass (Ref.)		Dimensions of assembly mm			Dimensions of slide unit mm									
		Slide unit kg	Track rail kg/m	H	H <sub>1</sub>	N	W <sub>2</sub>	W <sub>3</sub>	W <sub>4</sub>	L <sub>1</sub>	L <sub>2</sub>	L <sub>3</sub>	L <sub>4</sub>	d <sub>1</sub>	M <sub>1</sub>	H <sub>2</sub>
LWFF 33	☆	0.14	2.41	17	2.5	13.5	60	26.5	3.5	53.5	26	35.3	56	3.3	M4	6
LWFF 37	☆	0.23	3.05	21	3	15.5	68	30	4	62	29	40	66	4.4	M5	8
LWFF 42	☆	0.49	4.30	27	3	19	80	35	5	75	40	52.2	86	5.3	M6	10
LWFF 69	☆	1.40	9.51	35	4	25.5	120	53.5	6.5	109	60	79.5	119	7	M8	14

Note(1) : Track rail lengths are shown in Table 11.1 on page B-122.

(2) : The directions of basic dynamic load rating (C), basic static load rating (C<sub>0</sub>) and static moment rating (T<sub>0</sub>, T<sub>x</sub>, T<sub>y</sub>) are shown in the sketches below. The upper values in the T<sub>x</sub> and T<sub>y</sub> columns apply to one slide unit, and the lower values apply to two slide units in close contact.

Remark 1 : The mark ☆ indicates that interchangeable specification products are available.

2 : The appended track rail mounting bolts are hexagon socket head bolts of JIS B 1176 or equivalent.

3 : For grease nipple specifications, see page 99.

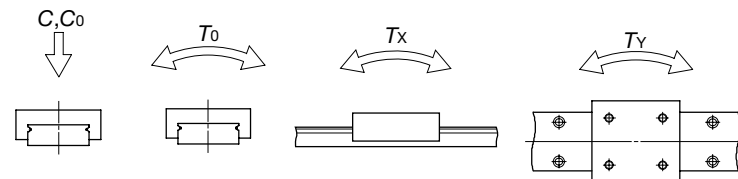

H <sub>3</sub>		H <sub>5</sub>		Dimensions of track rail mm								Mounting bolt for track rail mm	Basic dynamic load rating(2) C	Basic static load rating(2) C <sub>0</sub>	Static moment rating(2)		
W	H <sub>4</sub>	W <sub>5</sub>	W <sub>6</sub>	d <sub>3</sub>	d <sub>4</sub>	h	E	F	Bolt size x length	N	N	T <sub>0</sub>	T <sub>x</sub>	T <sub>y</sub>			
N·m	N·m	N·m	N·m	N·m	N·m	N·m	N·m	N·m									
3.2	3.7	33	10	18	7.5	4.6	8	6	20	40	M4×10	6 530	8 610	146	49.0 289	49.0 289	
4	4.5	37	11.5	22	7.5	4.6	8	6	25	50	M4×12	9 840	12 200	235	80.0 480	80.0 480	
6	7	42	14	24	9	4.6	8	6	30	60	M4×16	15 500	19 400	424	165 904	165 904	
8	8	69	19.5	40	14.5	7	11	9	40	80	M6×22	34 900	44 100	1 560	581 2 940	488 2 460	

Example of identification number of assembled set (For details, see "Identification number and specification".)

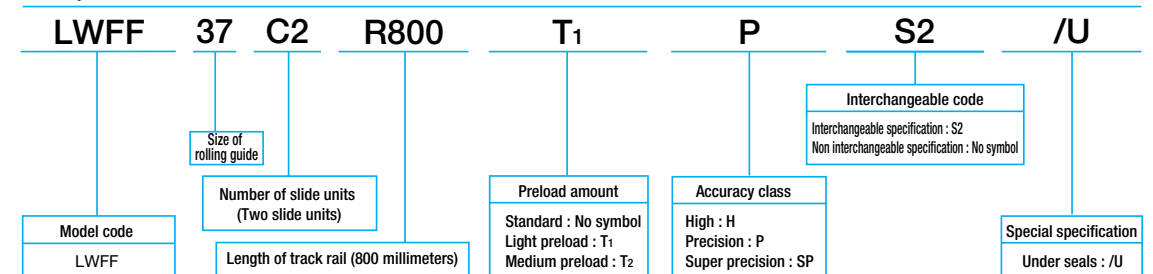

**Block type mounted from top**  
**LWFS**  
**LWFS...SL** (Stainless steel made)

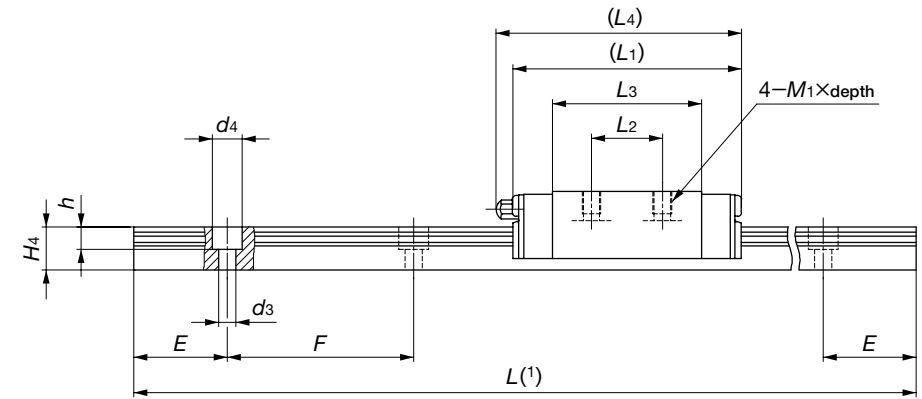
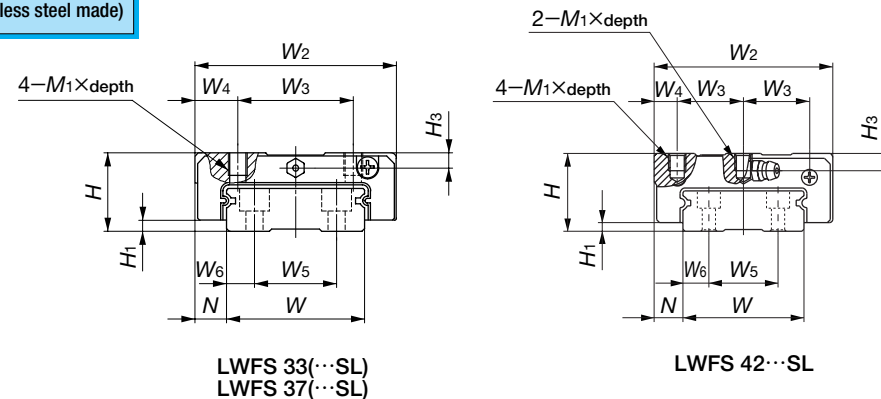

Model number	Interchangeable	Mass (Ref.)		Dimensions of assembly mm			Dimensions of slide unit mm							
		Slide unit kg	Track rail kg/m	H	H <sub>1</sub>	N	W <sub>2</sub>	W <sub>3</sub>	W <sub>4</sub>	L <sub>1</sub>	L <sub>2</sub>	L <sub>3</sub>	L <sub>4</sub>	M1×depth
LWFS 33	☆	0.13	2.41	17	2.5	8.5	50	29	10.5	53.5	15	35.3	56	M4×5
LWFS 33...SL	☆													
LWFS 37	☆	0.20	3.05	21	3	8.5	54	31	11.5	62	19	40	66	M5×6
LWFS 37...SL	☆													
LWFS 42...SL	☆	0.40	4.30	27	3	10	62	23	8	75	32	52.2	86	M6×6

H <sub>3</sub>	Dimensions of track rail mm									Mounting bolt for track rail mm Bolt size x length	Basic dynamic load rating <sup>(2)</sup> C N	Basic static load rating <sup>(2)</sup> C <sub>0</sub> N	Static moment rating <sup>(2)</sup>		
	W	H <sub>4</sub>	W <sub>5</sub>	W <sub>6</sub>	d <sub>3</sub>	d <sub>4</sub>	h	E	F				T <sub>0</sub> N·m	T <sub>x</sub> N·m	T <sub>y</sub> N·m
3.2	33	10	18	7.5	4.6	8	6	20	40	M4×10	6 530	8 610	146	49.0 289	49.0 289
4	37	11.5	22	7.5	4.6	8	6	25	50	M4×12	9 840	12 200	235	80.0 480	80.0 480
6	42	14	24	9	4.6	8	6	30	60	M4×16	15 500	19 400	424	165 904	165 904

Note<sup>(1)</sup>: Track rail lengths are shown in Table 11.1 on page B-122 and Table 11.2 on page B-123.  
<sup>(2)</sup>: The directions of basic dynamic load rating (C), basic static load rating (C<sub>0</sub>) and static moment rating (T<sub>0</sub>, T<sub>x</sub>, T<sub>y</sub>) are shown in the sketches below. The upper values in the T<sub>x</sub> and T<sub>y</sub> columns apply to one slide unit, and the lower values apply to two slide units in close contact.  
 Remark 1: The mark ☆ indicates that interchangeable specification products are available.  
 2: The appended track rail mounting bolts are hexagon socket head bolts of JIS B 1176 or equivalent.  
 For stainless steel type Linear Way F, stainless steel bolts are appended.  
 3: For grease nipple specifications, see page 99.

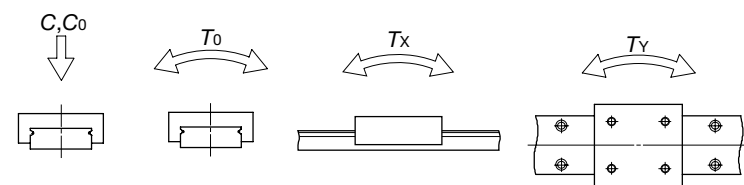

Example of identification number of assembled set (For details, see "Identification number and specification".)

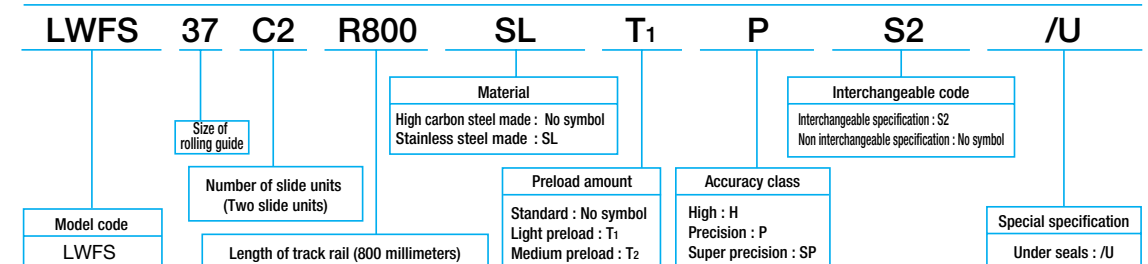

U.S. PATENTED

# Linear Way U

## LWU

**IKO Linear Way U** is a linear motion rolling guide featuring a track rail with a U-shaped cross section. Raceways are provided on the inside surface of the track rail, and a slide unit mounted inside the track rail travels along the raceways.

The U-shaped track rail has much higher rigidity as compared with the track rail with a rectangular cross section, especially under moment and torsion. Therefore, in addition to the conventional way of fastening a track rail on a mounting base, it can be used by itself as a structural member of machines and equipment, in a cantilever position or being supported at both ends.

### U-shaped track rail

Rigidity of track rail under moment and torsion is very much increased by adopting the U-shaped design. The track rails can, therefore, be mounted on machines and equipment as structural members, either in a cantilever position or supported at both ends, so they can be combined and assembled freely.

### Ball retained type

The slide unit of ball retained type incorporates ball retaining bands, which prevent steel balls from dropping when the slide unit is separated from the track rail. So handling is easy.

### High precision and rigidity

Large diameter steel balls in the slide unit are arranged in two rows, and makes contact with the raceways at four points. Stable high precision and rigidity are thus obtained even under fluctuating loads with changing direction and magnitude or complex loads.

### Additional work on track rail is possible

Additional work can be made on track rails of standard type, so that drive mechanisms and other peripheral devices can be fixed directly to the track rails. (※ Note that additional work cannot be made near the raceways of track rail. For details, consult **IKO** for further information.)

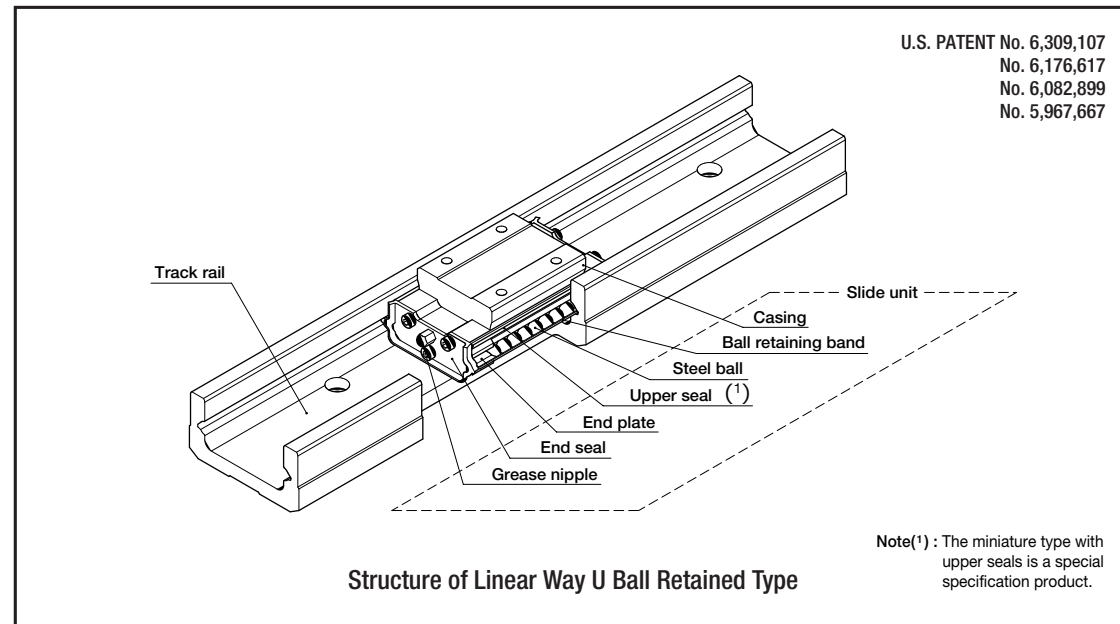

## Linear Way U series

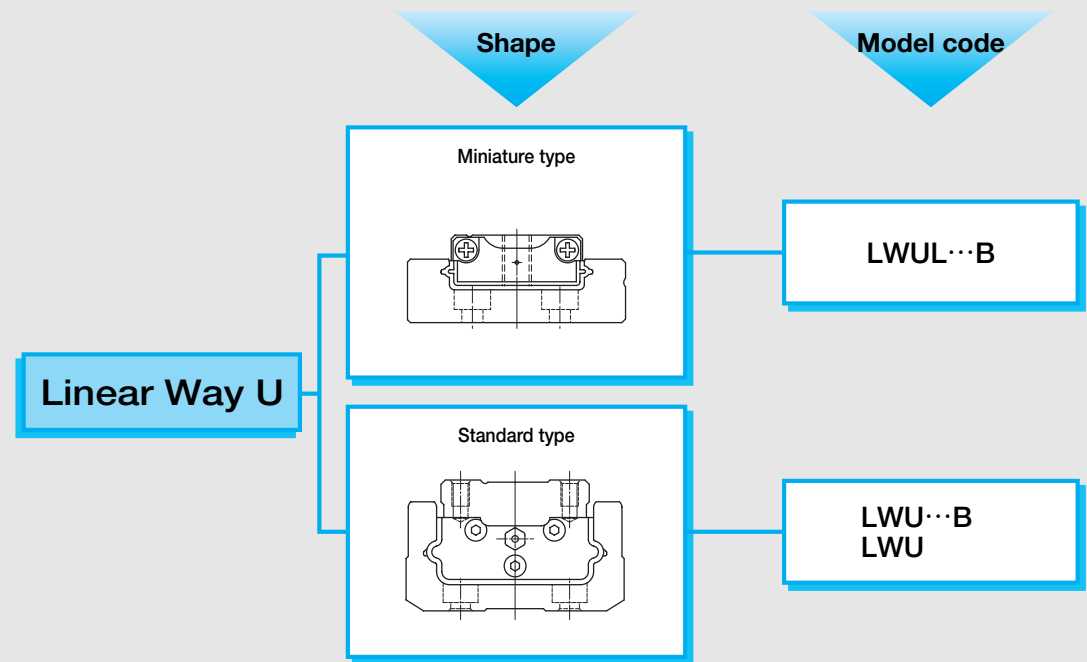

Remark : Models with "B" are ball retained type.

## ● Identification number and specification

The specification of Linear Way U is indicated by the identification number, consisting of a model code, a size, a part code, a preload symbol, a classification symbol and any supplemental codes. For details of each specification, see page 78.

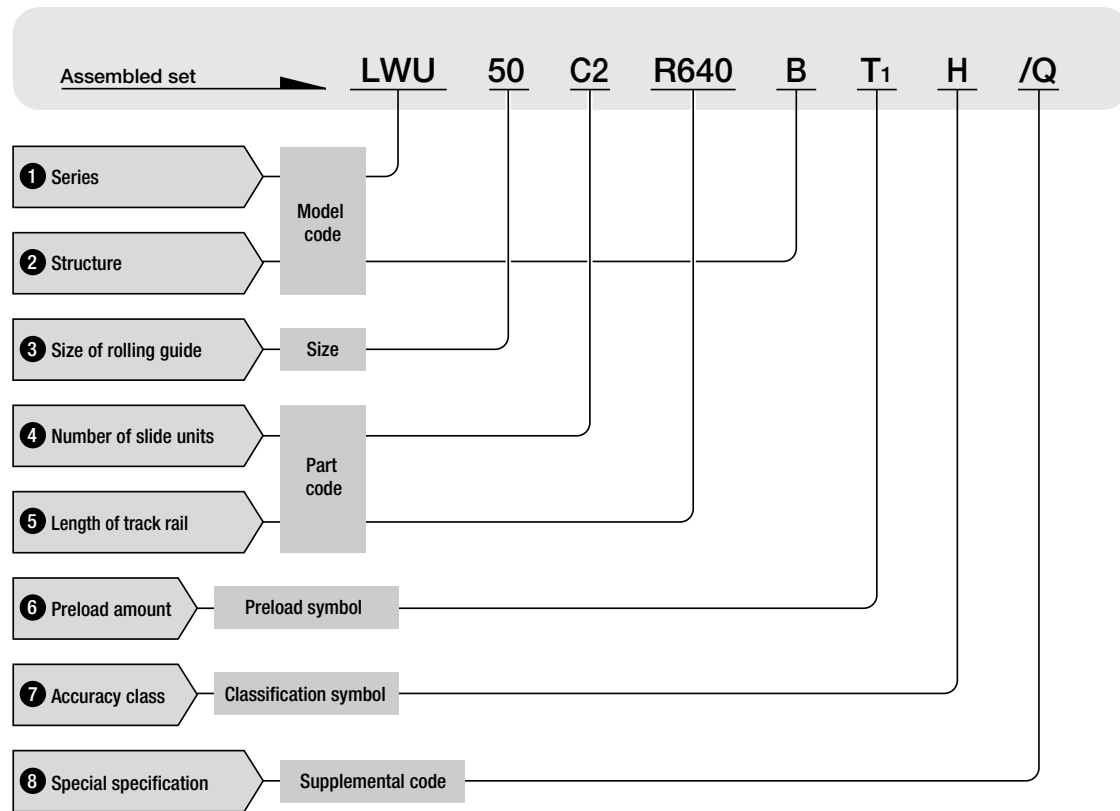

**1 Series**  
 Miniature type : LWUL  
 Standard type : LWU

---

**2 Structure**  
 Ball retained type : B  
 Ball non-retained type : No symbol  
 For available models and sizes, see Table 1.

---

**3 Size of rolling guide**

**Table 1 Models and sizes of Linear Way U**

Size	Model	Standard type	
	Stainless steel made	High carbon steel made	
		Ball retained type LWUL...B	Ball retained type LWU...B
25	○	—	—
30	○	—	—
40	—	○	○
50	—	○	○
60	—	○	○
86	—	○	○
100	—	—	○
130	—	—	○

**4 Number of slide units**  
 : C○ Indicate the number of slide units assembled on one track rail.

---

**5 Length of track rail**  
 : R○ Indicate the length of track rail in mm. For standard and maximum lengths, see "Track rail length" on page B-136.

---

**6 Preload amount**  
 Standard : No symbol  
 Light preload : T1  
 For details of preload amount, see page 86.

**7 Accuracy class**

Ordinary : No symbol  
 High : H  
 For details of accuracy, see page 81.

**8 Special specification**

For applicable special specifications, see Table 2.  
 When several special specifications are required, see Table 3. For details of special specifications, see page 88.

Table 2 Special specifications

Special specification	Supplemental code	Dimension
Specified rail mounting hole positions <sup>(1)</sup>	E	
Black chrome surface treatment <sup>(2)</sup>	L	
Supplied with track rail mounting bolt <sup>(3)</sup>	MA	See Table 4
Supplied without track rail mounting bolt <sup>(1)</sup>	MN	
Capillary plates <sup>(3)</sup>	Q	See Table 5
Upper seals <sup>(1)</sup>	U	See Table 6
Matched sets to be used as an assembled group	W	

Note<sup>(1)</sup> : Applicable to size 25 and 30 models.  
<sup>(2)</sup> : Only "LR" is applicable to size 25 and 30 models.  
<sup>(3)</sup> : Not applicable to size 25 and 30 models.

Table 3 Combination of special specifications

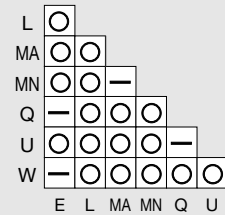

Remark : When several special specifications are required, arrange the supplemental codes alphabetically.

Table 4 Recommended track rail mounting bolt size (Supplemental code /MA)

Model number	Recommended bolt size
LWU 40...B	M 3× 8
LWU 50...B	M 4×10
LWU 60...B	M 5×12
LWU 86...B	M 6×16
LWU 100	M 8×20
LWU 130	M10×25

Remark 1 : The above table shows representative model numbers but is applicable to all models of the same size.  
 2 : Hexagon socket head bolts of strength division 12.9 of JIS B 1176 are recommended.

Table 5 Slide unit with capillary plates (Supplemental code /Q)

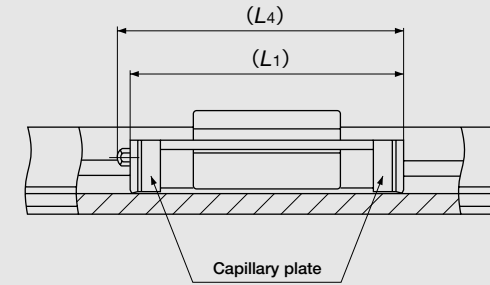

unit : mm

Model number	L1	L4
LWU 40...B	67	68
LWU 50...B	82	83
LWU 60...B	95	102
LWU 86...B	142	148
LWU 100	166	172
LWU 130	190	196

Remark : The above table shows representative model numbers but is applicable to all models of the same size.

Table 6 Slide unit with upper seals (Supplemental code /U)

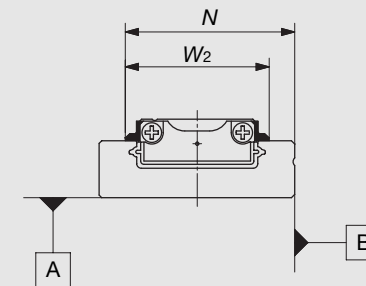

unit : mm

Model number	N	W2
LWUL 25...B	21.4	18
LWUL 30...B	25.9	22

## Track rail length

Standard and maximum lengths of track rails are shown in Table 7.

For miniature type, track rails in any length are also available. Simply indicate the necessary length of track rail in mm in the identification number. For the tolerances of *E* dimension and track rail length, consult **IICO** for further information.

- *E* dimensions at both ends are the same and are within the standard range of *E* unless otherwise specified. To change these dimensions, specify the specified rail mounting hole positions "/*E*" of special specification. For details, see page 91.

For standard type, when requiring track rails in any length other than the standard length, consult **IICO** for further information.

- For ball non-retained type track rails longer than the maximum length shown in Table 6, butt-jointing track rails are available upon request. When requiring, consult **IICO** for further information.

Table 7 Standard and maximum lengths of track rails

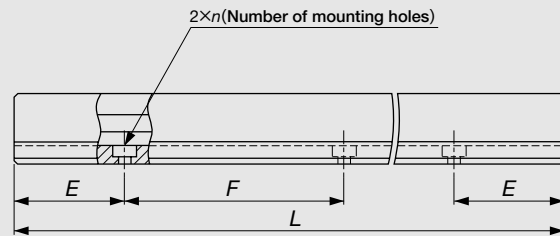

unit : mm

Model number	LWUL 25···B	LWUL 30···B	LWU 40···B LWU 40	LWU 50···B LWU 50
Standard length <i>L</i> ( <i>n</i> )	105(3) 140(4) 175(5) 210(6) 245(7) 280(8)	120(3) 160(4) 200(5) 240(6) 280(7) 320(8)	180(3) 240(4) 300(5) 360(6) 420(7) 480(8)	240(3) 320(4) 400(5) 480(6) 560(7) 640(8)
Pitch of mounting holes <i>F</i>	35	40	60	80
<i>E</i>	17.5	20	30	40
Standard range of <i>E</i>	incl. 4.5	4.5	—	—
	under 22	24.5	—	—
Maximum length <sup>(1)</sup>	420 (840)	480 (960)	720	800
Model number	LWU 60···B LWU 60	LWU 86···B LWU 86	LWU 100	LWU 130
Standard length <i>L</i> ( <i>n</i> )	300(3) 400(4) 500(5) 600(6) 700(7) 800(8)	300(3) 400(4) 500(5) 600(6) 700(7) 800(8)	450(3) 600(4) 750(5) 900(6) 1 050(7) 1 200(8)	450(3) 600(4) 750(5) 900(6) 1 050(7) 1 200(8)
Pitch of mounting holes <i>F</i>	100	100	150	150
<i>E</i>	50	50	75	75
Maximum length <sup>(1)</sup>	1 000	1 200	1 500	1 500

Note<sup>(1)</sup> : Track rails with the maximum lengths shown in parentheses can also be manufactured. Consult **IICO** for further information.

Remark : M8 female threads for hanging bolt are provided on the track rail of size 100 model. And M10 female threads for hanging bolt are provided on the track rail of size 130 model.

## Moment of inertia of sectional area

Table 8 shows the moment of inertia of sectional area of track rails.

Table 8 Moment of inertia of sectional area of track rails

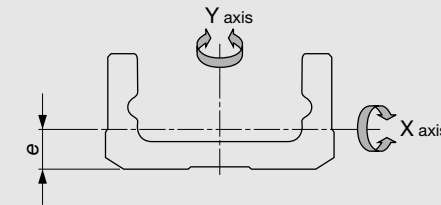

Model number	Moment of inertia of sectional area mm <sup>4</sup>		Center of gravity <i>e</i> mm
	<i>I<sub>x</sub></i>	<i>I<sub>y</sub></i>	
LWUL 25···B	3.7 × 10 <sup>2</sup>	7.5 × 10 <sup>3</sup>	2.6
LWUL 30···B	9.3 × 10 <sup>2</sup>	1.7 × 10 <sup>4</sup>	3.3
LWU 40···B	1.0 × 10 <sup>4</sup>	6.8 × 10 <sup>4</sup>	6.6
LWU 40		6.9 × 10 <sup>4</sup>	
LWU 50···B	2.8 × 10 <sup>4</sup>	1.7 × 10 <sup>5</sup>	8.7
LWU 50			
LWU 60···B	6.3 × 10 <sup>4</sup>	3.9 × 10 <sup>5</sup>	10.7
LWU 60			10.8
LWU 86···B	2.4 × 10 <sup>5</sup>	1.6 × 10 <sup>6</sup>	14.6
LWU 86			
LWU 100	5.9 × 10 <sup>5</sup>	3.3 × 10 <sup>6</sup>	18.8
LWU 130	1.4 × 10 <sup>6</sup>	8.8 × 10 <sup>6</sup>	23.0

**Ball retained type**  
**Miniature type : LWUL...B**  
**Standard type : LWU ...B**

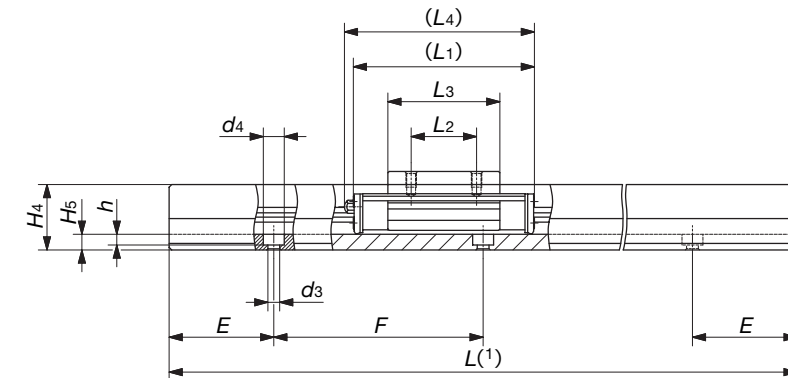
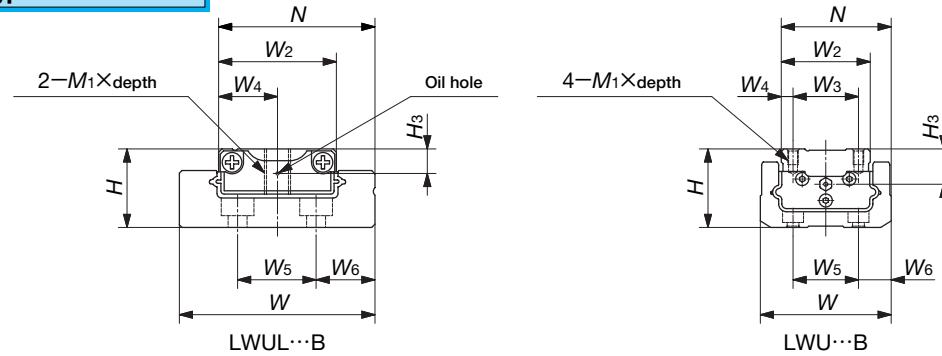

Model number	Mass (Ref.)		Dimensions of assembly mm		Dimensions of slide unit mm								
	Slide unit kg	Track rail kg/m	H	N	W <sub>2</sub>	W <sub>3</sub>	W <sub>4</sub>	L <sub>1</sub>	L <sub>2</sub>	L <sub>3</sub>	L <sub>4</sub>	M1×depth	H <sub>3</sub>
LWUL 25...B	0.013	0.87	9	19.4	14	—	7	31	12	22	—	M3× 5	2.9
LWUL 30...B	0.029	1.39	12	23.9	18	—	9	38	14	28.6	—	M4× 7	3.75
LWU 40...B	0.12	2.65	24	33	26	18	4	55	18	31.5	59	M3× 5	10.5
LWU 50...B	0.27	4.06	30	42	34	25	4.5	70	25	42.8	73	M4× 6	13.5
LWU 60...B	0.40	6.66	35	49	38	28	5	83	28	52.4	90	M5× 8	14.5
LWU 86...B	1.32	14.1	48	71	56	46	5	130	46	93	136	M6×12	25.5

Note(1) : Track rail lengths are shown in Table 7 on page B-136.

(2) : The directions of basic dynamic load rating (C), basic static load rating (C<sub>0</sub>) and static moment rating (T<sub>0</sub>, T<sub>x</sub>, T<sub>y</sub>) are shown in the sketches below. The upper values in the T<sub>x</sub> and T<sub>y</sub> columns apply to one slide unit, and the lower values apply to two slide units in close contact.

Remark 1 : For grease nipple and oil hole specifications, see page 99.

2 : The appended track rail mounting bolts are hexagon socket head bolts of JIS B 1176 or equivalent, or cross-recessed head screws for precision equipment. For stainless steel type Linear Way U, stainless steel bolts or screws are appended.

3 : Track rail mounting bolts are not appended to model size 40, 50, 60 and 88. Hexagon socket head cap bolts of JIS B 1176 in strength division 12.9 are recommended. Please see Table 4 on page B-134.

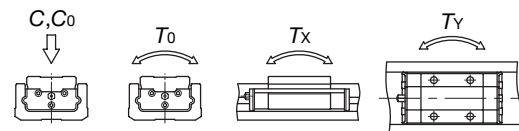

Dimensions of track rail mm										Mounting bolt for track rail mm	Basic dynamic load rating <sup>(2)</sup>	Basic static load rating <sup>(2)</sup>	Static moment rating <sup>(2)</sup>		
W	H <sub>4</sub>	H <sub>5</sub>	W <sub>5</sub>	W <sub>6</sub>	d <sub>3</sub>	d <sub>4</sub>	h	E	F				Bolt size x length	C N	C <sub>0</sub> N
24.9	6.7	3.2	9	8	2.9	4.8	1.6	17.5	35	Cross recessed head screw for precision equipment M2.5×6	1 770	2 840	20.3	10.1 53.7	8.4 45.0
29.9	8.7	4.5	12	9	2.9	5	2.7	20	40	Hexagon socket head bolt M2.5×6	2 280	3 810	34.9	16.9 87.5	14.2 73.4
40	19	5	18	11	3.4	6.5	3.1	30	60	Not appended	8 410	9 780	134	53.0 351	53.0 351
50	25	6	25	12.5	4.5	8	4.1	40	80	Not appended	13 500	15 800	280	114 711	114 711
60	30	8	28	16	5.5	9.5	5.4	50	100	Not appended	18 800	21 600	425	181 1 150	181 1 150
86	42	13	46	20	7	11	7	50	100	Not appended	41 400	51 500	1 470	764 4 120	764 4 120

Example of identification number (For details, see "Identification number and specification".)

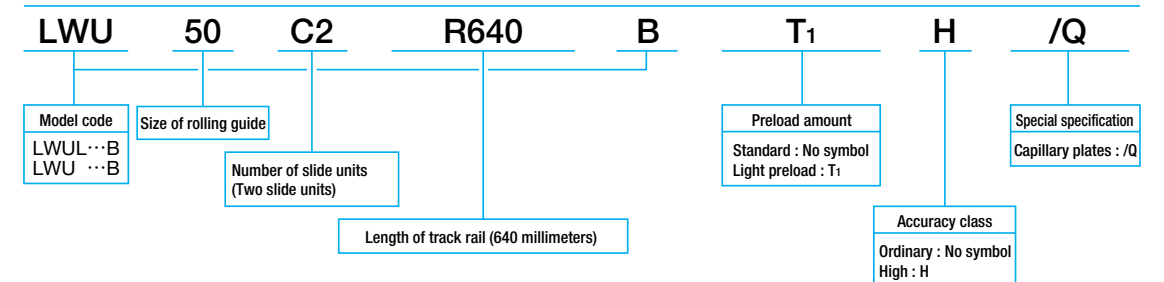



Ball non-retained type  
Standard type : LWU

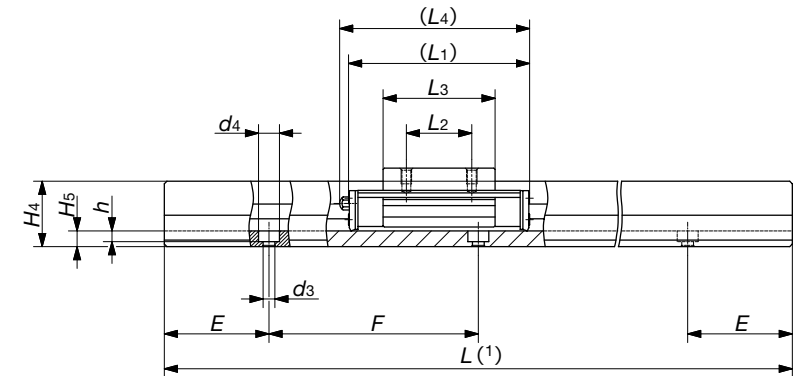
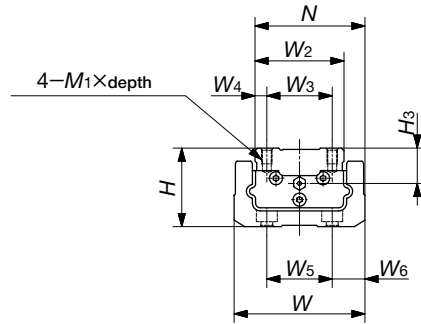

Model number	Mass (Ref.)		Dimensions of assembly mm		Dimensions of slide unit mm									
	Slide unit kg	Track rail kg/m	H	N	W <sub>2</sub>	W <sub>3</sub>	W <sub>4</sub>	L <sub>1</sub>	L <sub>2</sub>	L <sub>3</sub>	L <sub>4</sub>	M <sub>1</sub> ×depth	H <sub>3</sub>	W
LWU 40	0.12	2.66	24	33	26	18	4	55	18	31.5	59	M 3×5	10.5	40
LWU 50	0.27	4.08	30	42	34	25	4.5	70	25	42.8	73	M 4×6	13.5	50
LWU 60	0.40	6.69	35	49	38	28	5	83	28	52.4	90	M 5×8	14.5	60
LWU 86	1.32	14.1	48	71	56	46	5	130	46	93	136	M 6×12	25.5	86
LWU 100	2.20	21.5	58	82	65	50	7.5	154	50	111	158	M 8×15	29	99.5
LWU 130	4.49	33.0	72	109	88	70	9	178	70	132	182	M10×20	35.5	130

Note(1) : Track rail lengths are shown in Table 7 on page B-136.

(2) : The directions of basic dynamic load rating (C), basic static load rating (C<sub>0</sub>) and static moment rating (T<sub>0</sub>, T<sub>x</sub>, T<sub>y</sub>) are shown in the sketches below. The upper values in the T<sub>x</sub> and T<sub>y</sub> columns apply to one slide unit, and the lower values apply to two slide units in close contact.

Remark 1 : Track rail mounting bolts are not appended. Hexagon socket head cap bolts of JIS B 1176 in strength division 12.9 are recommended.

Please see Table 4 on page B-134.

2 : For grease nipple specifications, see page 99.

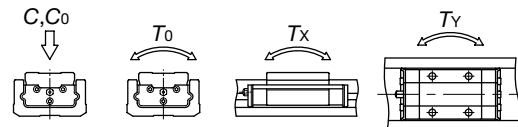

Dimensions of track rail mm										Basic dynamic load rating <sup>(2)</sup> C N	Basic static load rating <sup>(2)</sup> C <sub>0</sub> N	Static moment rating <sup>(2)</sup>		
H <sub>4</sub>	H <sub>5</sub>	W <sub>5</sub>	W <sub>6</sub>	d <sub>3</sub>	d <sub>4</sub>	h	E	F				T <sub>0</sub> N·m	T <sub>x</sub> N·m	T <sub>y</sub> N·m
19	5	18	11	3.4	6.5	3.1	30	60		8 410	9 780	134	53.0 351	53.0 351
25	6	25	12.5	4.5	8	4.1	40	80		13 500	15 800	280	114 711	114 711
30	8	28	16	5.5	9.5	5.4	50	100		18 800	21 600	425	181 1 150	181 1 150
42	13	46	20	7	11	7	50	100		41 400	51 500	1 470	764 4 120	764 4 120
52	17	50	24.5	9	14	9	75	150		54 600	68 500	2 230	1 210 6 460	1 210 6 460
65	20	70	30	11	17.5	10.6	75	150		70 300	88 800	3 920	1 830 9 630	1 830 9 630

Example of identification number (For details, see "Identification number and specification".)

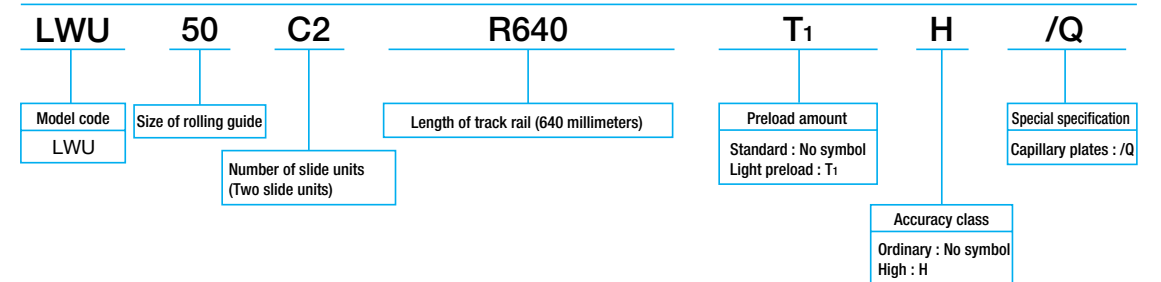

U.S. PATENTED

# Linear Way Module

LWLM/LWM

**I**KO Linear Way Module is a compact linear motion rolling guide for endless linear motion, and consists of a set of track rail and slide member which forms the smallest unit of linear motion mechanism. Various models are available for selection suitable for each application. In general, two sets are used in parallel.

## Compact

The one row, four point contact design has achieved a compact product, which can be mounted in a very small space. It can be easily adapted to the structure of machines and equipment, providing a high degree of freedom in machine design.

## Low height

As the sectional height is low, Linear Way Modules can be easily adapted to the structure of machines and equipment.

## Linear Way Module LM

As stainless steel components are used, Linear Way Module LM has excellent corrosion resistance and is most suitable for machines and equipment used in clean environments, for example, medical equipment, disk read devices, and semi-conductor manufacturing equipment.

## Linear Way Module M

Linear Way Module M is a standard type, incorporating steel balls as rolling elements.

U.S. PATENT No. 4,505,522  
No. 4,688,950  
No. 4,504,097

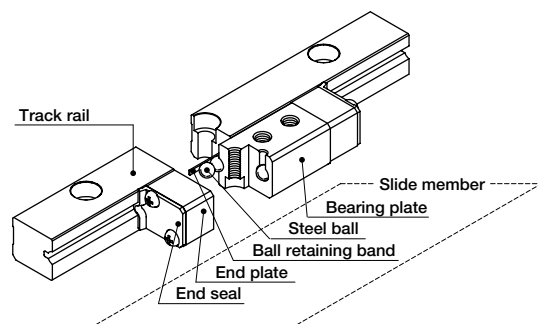

Structure of Linear Way Module M

## Linear Way Module series

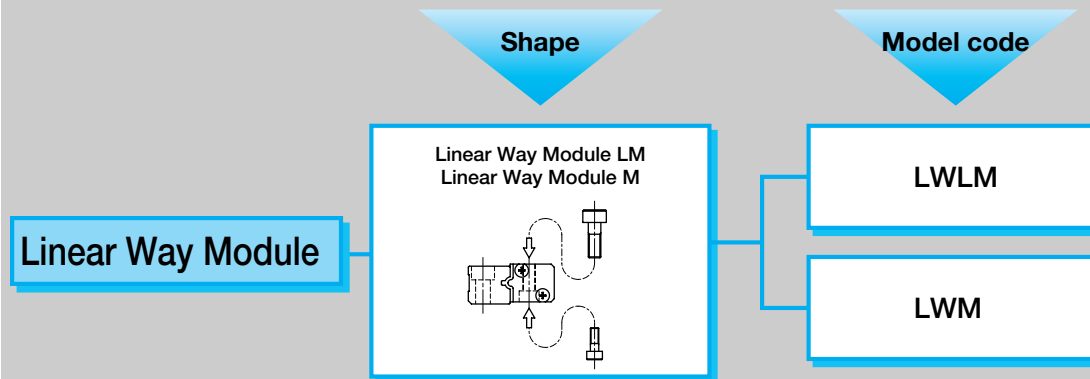

## ● Identification number and specification

The specification of Linear Way Module is indicated by the identification number, consisting of a model code, a size, a part code, a classification symbol and any supplemental codes. For details of each specification, see page 78.

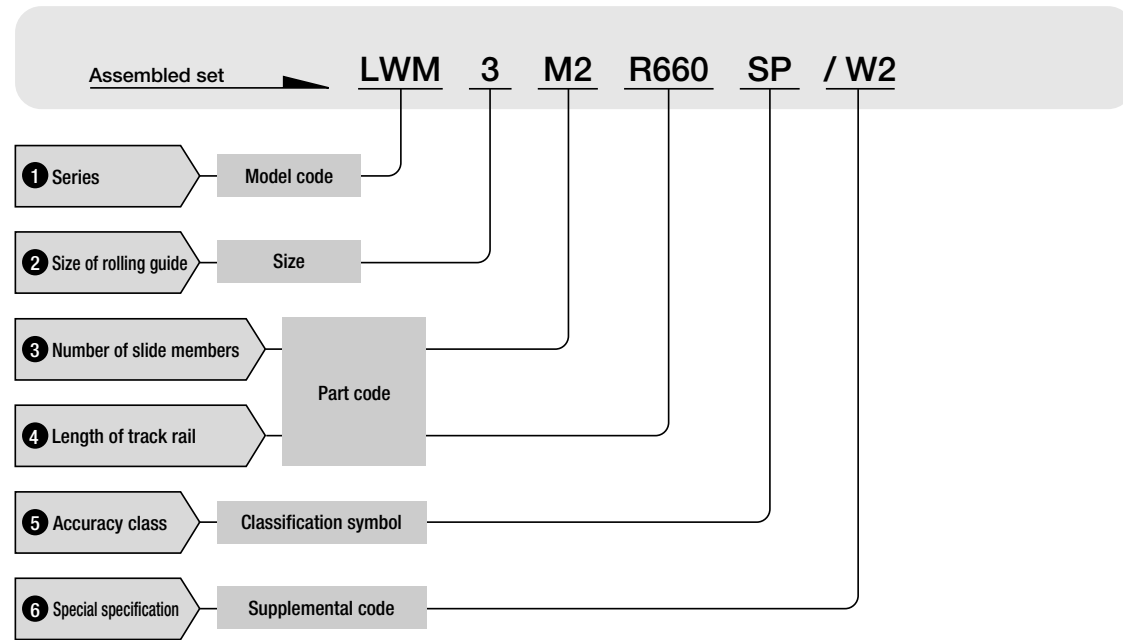

**Remark :** Above identification number indicates an assembled set consisting of one track rail and two slide members (in case of above example). It is needed to place an order of two sets of above, when two rails are set in parallel.

<b>1 Series</b>	Linear Way Module LM : LWLM Linear Way Module M : LWM	
<b>2 Size of rolling guide</b>		See the table of dimensions of each series.
<b>3 Number of slide members</b>	: M○	Indicate the number of slide members assembled on one track rail.
<b>4 Length of track rail</b>	: R○	Indicate the length of track rail in mm. For standard and maximum lengths, see "Track rail length" on page B-147.
<b>5 Accuracy class</b>	High : H Precision : P Super precision : SP	For details of accuracy, see page 81.
<b>6 Special specification</b>		For applicable special specifications, see Table 1. When several special specifications are combined, see Table 2. For details of special specifications, see page 88.

Table 1 Special specifications

Special specification	Supplemental code	Linear Way LM	Linear Way M	Linear Roller Way M
Butt-jointing track rail	A	—	○	○
Specified rail mounting hole positions	E	○	○	○
Caps for rail mounting holes	F	—	○	○
Inspection sheet	I	○	○	○
Black chrome surface treatment	LR	—	○	○
Fluorine black chrome surface treatment	LFR	—	○	○
Supplied without track rail mounting bolt	MN	○	○(1)	○(1)
Matched sets to be used as an assembled group	W	○	○	○
Specified grease	Y	○	○	○

Table 2 Combination of special specifications

E	—																		
F	○	○																	
I	○	○	○																
LR	○	○	○	○															
LFR	○	○	○	○	○	—													
MN	○	○	○	○	○	○	○												
W	○	—	○	○	○	○	○	○											
Y	○	○	○	○	○	○	○	○	○										
	A	E	F	I	LR	LFR	MN	W											

Remark 1 : In the table, the mark — indicates that this combination cannot be made.  
 2 : When several special specifications are required, arrange the supplemental codes alphabetically.

## Track rail length

Standard and maximum lengths of track rails are shown in Table 3. Track rails in any length are also available. Simply indicate the necessary length of track rail in mm in the identification number. For the tolerances of *E* dimension and track rail length, consult **IKO** for further information.

- For track rails of Linear Way Module M longer than the maximum length shown in Table 3, butt-jointing track rails are available upon request. In this case, indicate "/A" in the identification number.
- *E* dimensions at both ends are the same and are within the standard range of *E* unless otherwise specified. To change these dimensions, specify the specified rail mounting hole positions "/E" of special specification. For details, see page 91.

Table 3 Standard and maximum lengths of track rails

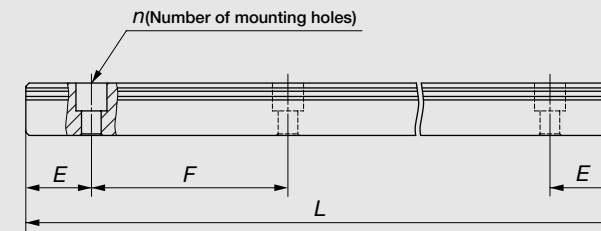

unit : mm

Item	Model number	LWLM 7	LWLM 9	LWLM 11			
Standard length <i>L</i> ( <i>n</i> )		60(3)	100( 4)	160( 4)			
		80(4)	150( 6)	240( 6)			
		120(6)	200( 8)	320( 8)			
		160(8)	275(11)	440(11)			
Pitch of mounting holes <i>F</i>		20	25	40			
<i>E</i>		10	12.5	20			
Standard range of <i>E</i>	incl.	4.5	5	5.5			
	under	14.5	17.5	25.5			
Maximum length <sup>(1)</sup>		240	350	520			
		(500)	(900)	(1 000)			
Item	Model number	LWM 1	LWM 2	LWM 3	LWM 4	LWM 5	LWM 6
Standard length <i>L</i> ( <i>n</i> )		240( 6)	240(4)	480( 8)	800(10)	800( 8)	1 200(10)
		360( 9)	360(6)	660(11)	1 040(13)	1 200(12)	1 920(16)
		480(12)	480(8)	840(14)	1 200(15)	1 500(15)	2 520(21)
Pitch of mounting holes <i>F</i>		40	60	60	80	100	120
<i>E</i>		20	30	30	40	50	60
Standard range of <i>E</i>	incl.	7	8	9	10	12	13
	under	27	38	39	50	62	73
Maximum length		1 240	1 260	1 260	1 520	1 500	2 520

Note<sup>(1)</sup> : Track rails with the maximum lengths shown in parentheses can also be manufactured for LWLM. Consult **IKO** for further information.

**Linear Way Module LM**  
**LWLM** (Stainless steel made)

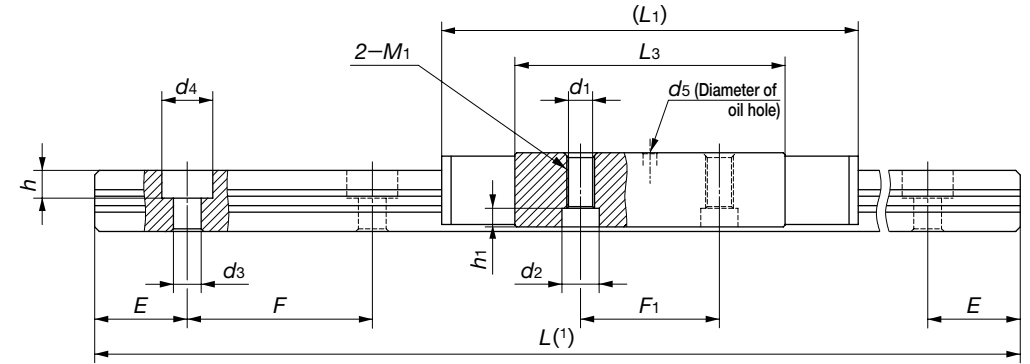
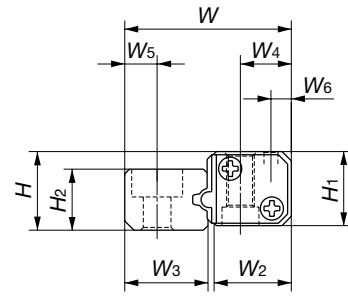

Model number	Mass (Ref.)		Dimensions of assembly mm		Dimensions of slide member mm											
	Slide member g	Track rail g/m	H	W	H <sub>1</sub>	W <sub>2</sub>	W <sub>4</sub>	W <sub>6</sub>	L <sub>1</sub>	L <sub>3</sub>	F <sub>1</sub>	d <sub>1</sub>	d <sub>2</sub>	h <sub>1</sub>	M <sub>1</sub>	d <sub>5</sub>
<b>LWLM 7</b>	10	210	7	15	6.6	7.8	5	2.5	38	24	12	—	—	—	M2.6	1
<b>LWLM 9</b>	16	390	8.5	18	8	8.6	5.5	2.2	45	29.2	15	—	—	—	M3	1.5
<b>LWLM 11</b>	32	590	11	23	10	11.8	7	3	52	32.8	15	2.55	5	3	M3	2

Note(1) : Track rail lengths are shown in Table 3 on page B-147.

(2) : The directions of basic dynamic load rating (C) and basic static load rating (C<sub>0</sub>) are shown in the sketch below.

(3) : In LWLM7, counter bore is not provided to the track rail. Total height of track rail including bolt head is 7.4mm.

Remark 1 : The appended track rail mounting bolts are hexagon socket head stainless steel bolts of JIS B 1176 or equivalent.  
2 : Slide member mounting bolts are not appended.

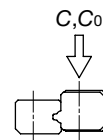

Dimensions of track rail mm								Mounting bolt for track rail mm Bolt size x length	Basic dynamic load rating <sup>(2)</sup> C N	Basic static load rating <sup>(2)</sup> C <sub>0</sub> N
H <sub>2</sub>	W <sub>3</sub>	W <sub>5</sub>	d <sub>3</sub>	d <sub>4</sub>	h	E	F			
4.8	6.8	3.3	3 <sup>(3)</sup>	— <sup>(3)</sup>	— <sup>(3)</sup>	10	20	M 2.6× 8 <sup>(3)</sup>	1 730	2 020
6.6	9	3.5	3	5.5	3	12.5	25	M 2.6× 8	2 780	3 150
8	10.8	5	3.5	6	4.5	20	40	M 3 × 8	4 080	4 240

Example of identification number (For details, see "Identification number and specification".)

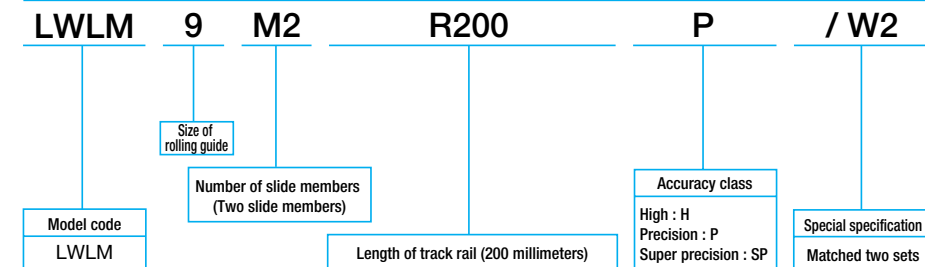

## Linear Way Module M LWM

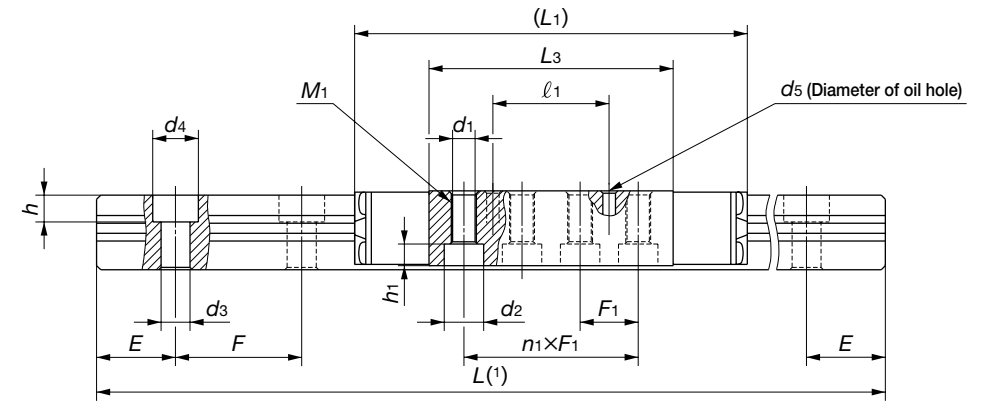
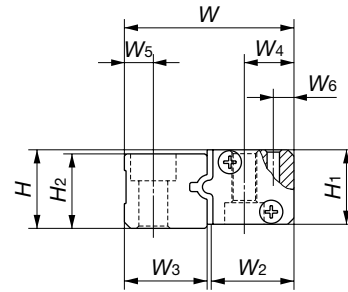

Model number	Mass (Ref.)		Dimensions of assembly mm		Dimensions of slide member mm									
	Slide member g	Track rail g/m	H	W	H <sub>1</sub>	W <sub>2</sub>	W <sub>4</sub>	W <sub>6</sub>	L <sub>1</sub>	L <sub>3</sub>	n <sub>1</sub> ×F <sub>1</sub>	d <sub>1</sub>	d <sub>2</sub>	h <sub>1</sub>
LWM 1	0.07	1.20	14	28	13	14.6	9	4	65	41.2	2×13	3.4	6.5	3.1
LWM 2	0.11	1.93	17	35	16	17	10	4	75	47.2	2×15	4.4	8	4.1
LWM 3	0.17	2.71	19	41	18	20	12	5	95	58.8	3×14	5.4	9.5	5.2
LWM 4	0.32	3.49	21	51	20	25	15	6	125	80.6	3×20	6.8	11	6.2
LWM 5	0.56	5.25	25	63	24	30	18	8	145	94.8	4×20	6.8	11	6.2
LWM 6	1.35	7.56	31	78	30	40	24	11	180	131	5×22	8.6	14	8.2

Note(1) : Track rail lengths are shown in Table 3 on page B-147.

(2) : The directions of basic dynamic load rating (C) and basic static load rating (C<sub>0</sub>) are shown in the sketch below.

Remark : The appended slide member and track rail mounting bolts are hexagon socket head bolts of JIS B 1176 or equivalent.

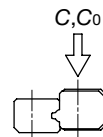

M <sub>1</sub>	l <sub>1</sub>	d <sub>5</sub>	Mounting bolt for slide member mm Bolt size x length	Dimensions of track rail mm								Mounting bolt for track rail mm Bolt size x length	Basic dynamic load rating <sup>(2)</sup> C N	Basic static load rating <sup>(2)</sup> C <sub>0</sub> N
				H <sub>2</sub>	W <sub>3</sub>	W <sub>5</sub>	d <sub>3</sub>	d <sub>4</sub>	h	E	F			
M 4	13	2	M3×14	13	13	5.5	4.5	8	4.5	20	40	M 4×14	4 720	6 410
M 5	15	3	M4×18	16	17	6	6	9.5	5.4	30	60	M 5×18	7 150	9 240
M 6	—	3	M5×20	18	20	7	7	11	6.5	30	60	M 6×20	13 700	16 600
M 8	—	3	M6×22	20	25	9	9	14	9	40	80	M 8×22	23 200	27 400
M 8	20	3	M6×28	24	31	12	11	17.5	11	50	100	M10×25	35 300	41 000
M10	—	3	M8×35	30	36	14	14	20	13	60	120	M12×35	74 100	80 900

Example of identification number (For details, see "Identification number and specification".)

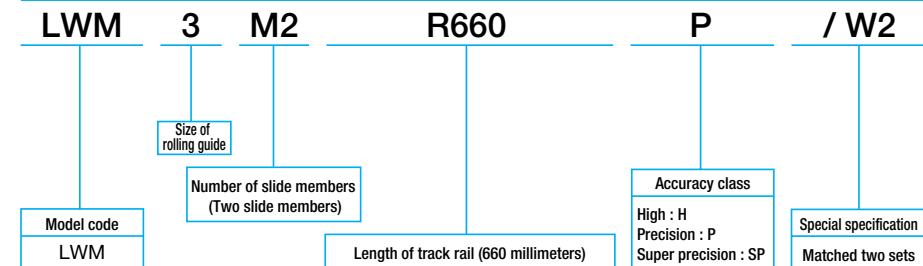



# Linear Roller Way

Description and Table of dimensions

C

Linear Roller Way Super X

Page C-2 to C-29

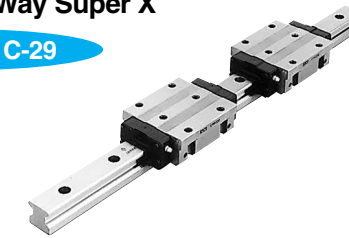

In the table of dimensions, standard products are referred to using identification numbers marked with  . The identification numbers marked with   refer to our semi-standard products.



U.S. PATENTED

# Linear Roller Way Super X

LRX/LRXD/LRXS

**IICO** Linear Roller Way Super X is a high performance roller type linear motion rolling guide, featuring high reliability, high rigidity, high accuracy, and smooth motion. Four rows of cylindrical rollers are incorporated in a highly rigid casing with good balance, and the cylindrical rollers in each row are arranged in parallel to each other. Owing to its small elastic deformation, stable operation is ensured even under heavy or fluctuating loads. This series is also suitable for applications with vibration and shocks. Various models and sizes are available to meet requirements in each application.

## Interchangeable

Linear Roller Way Super X includes interchangeable specification products. The dimensions of slide units and track rails of this specification are individually controlled, so that the slide units and track rails can be combined, added or exchanged freely.

## Variable length of slide unit

Three types of slide units, the short slide unit, the standard slide unit and the high rigidity long slide unit with the same sectional dimensions are available for selection suitable for each application.

## Flange type and block type

Slide units are available in two different sectional shapes: the flange type for mounting from both upper and lower sides and the block type with a narrow width.

## Dimensional interchangeability with the ball type

The mounting dimensions are the same as those of ball type Linear Way H. So this guide can replace the ball type with little modifications of machines or equipment.

## Stainless steel type

The stainless steel type has excellent corrosion resistance, and is best suited for machines and equipment used in clean environments, for example, medical equipment and semi-conductor manufacturing equipment.

U.S. PATENT No. 6,176,617  
No. 5,967,667  
No. 5,800,064  
No. 5,193,914  
No. 4,505,522

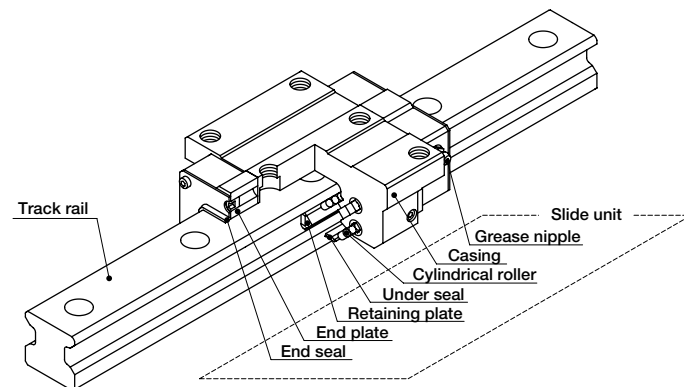

Structure of Linear Roller Way Super X

## Linear roller Way Super X series

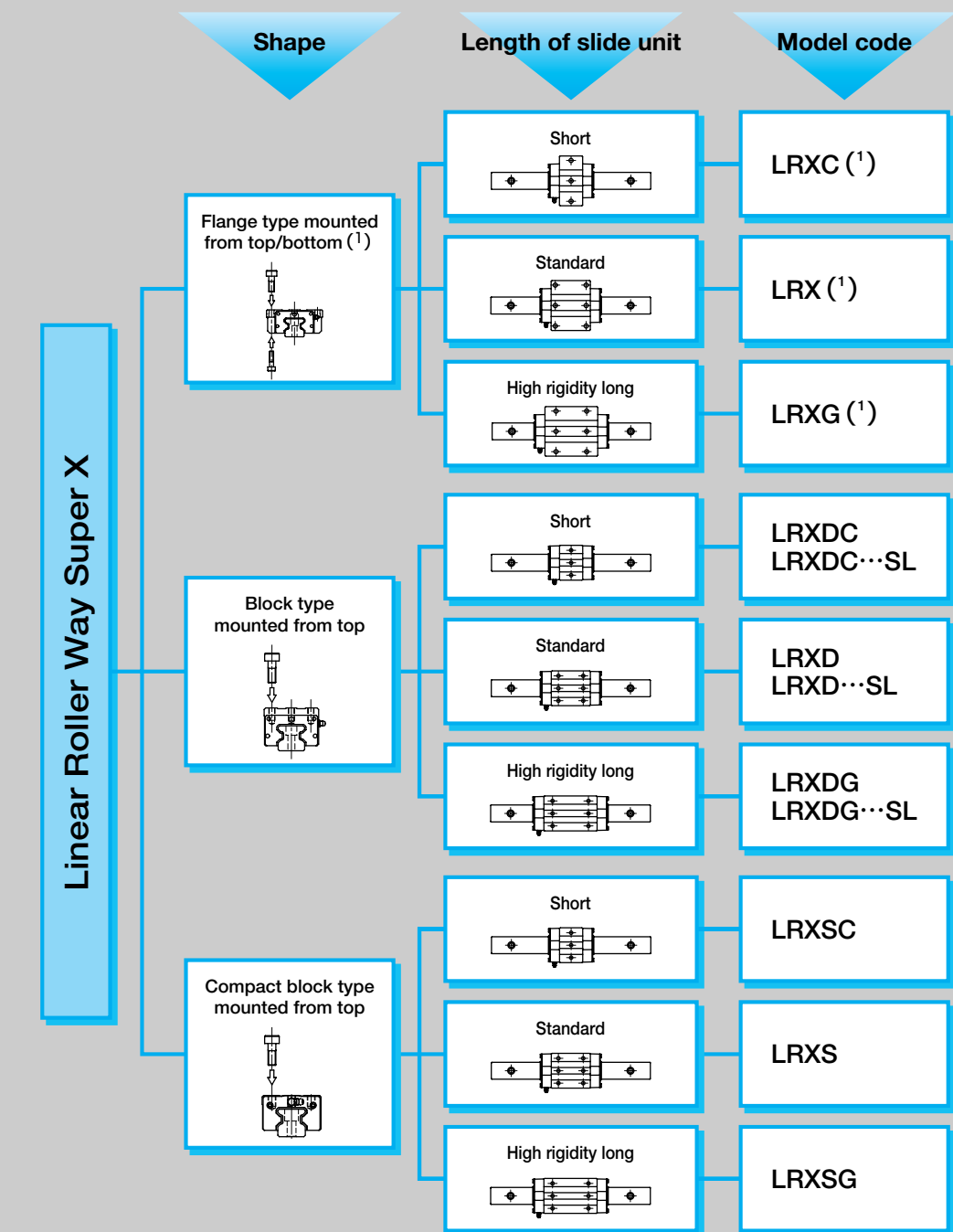

Note(1) : LRXC20, LRX20 and LRXG20 can be mounted from upper side only. For mounting from bottom, LRXHC20, LRXH20 and LRXHG20 can be used, which have the same dimensions as those of the above models.  
Remark : Models with "SL" are stainless steel type.

## ● Identification number and specification

The specification of Linear Roller Way Super X is indicated by the identification number, consisting of a model code, a size, a part code, a material symbol, a preload symbol, a classification symbol, an interchangeable code and any supplemental codes. For details of each specification, see page 78.

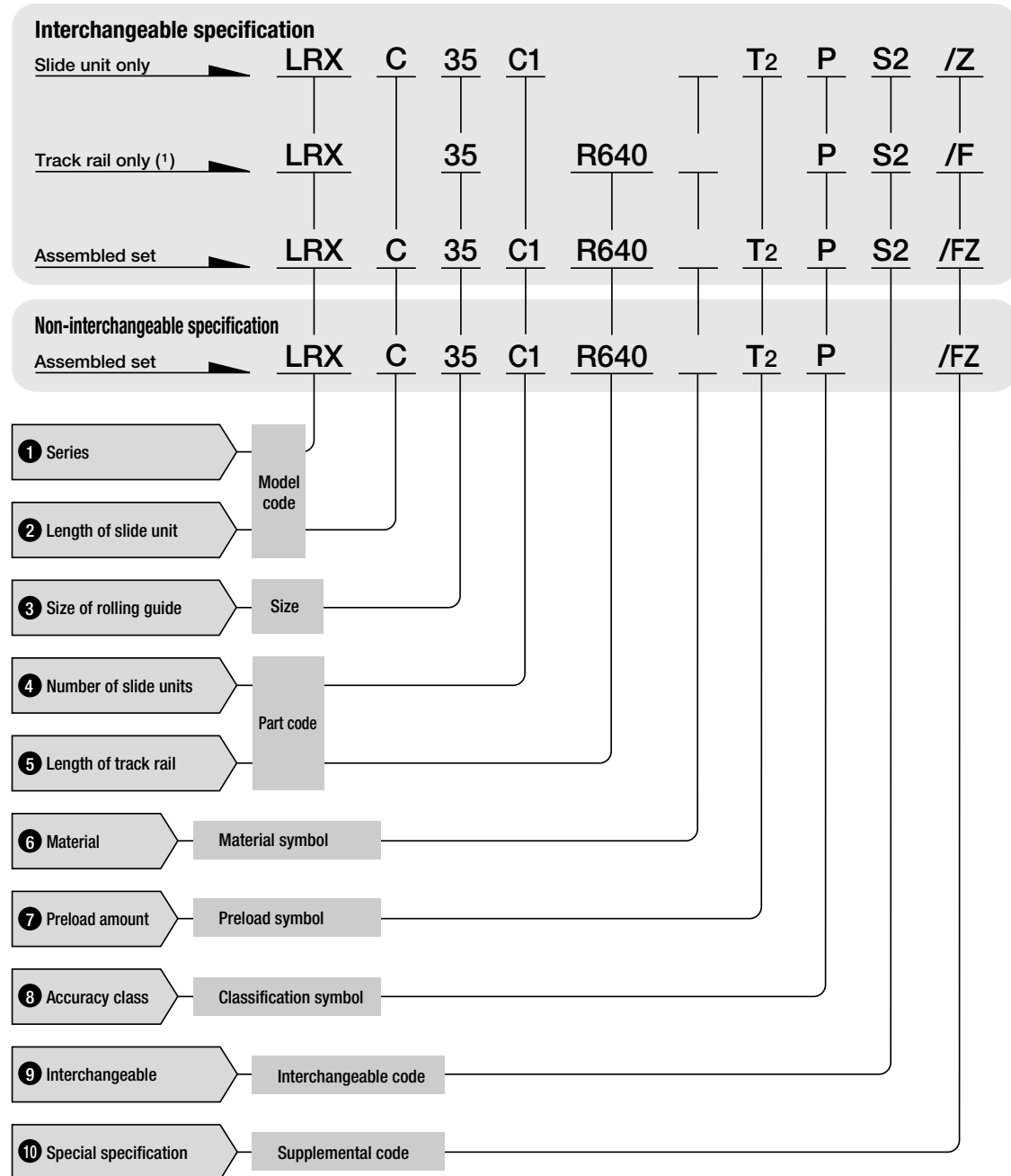

Note(1) : For the model code of a single track rail of interchangeable specification, indicate "LRX" regardless of the slide unit type to be combined.

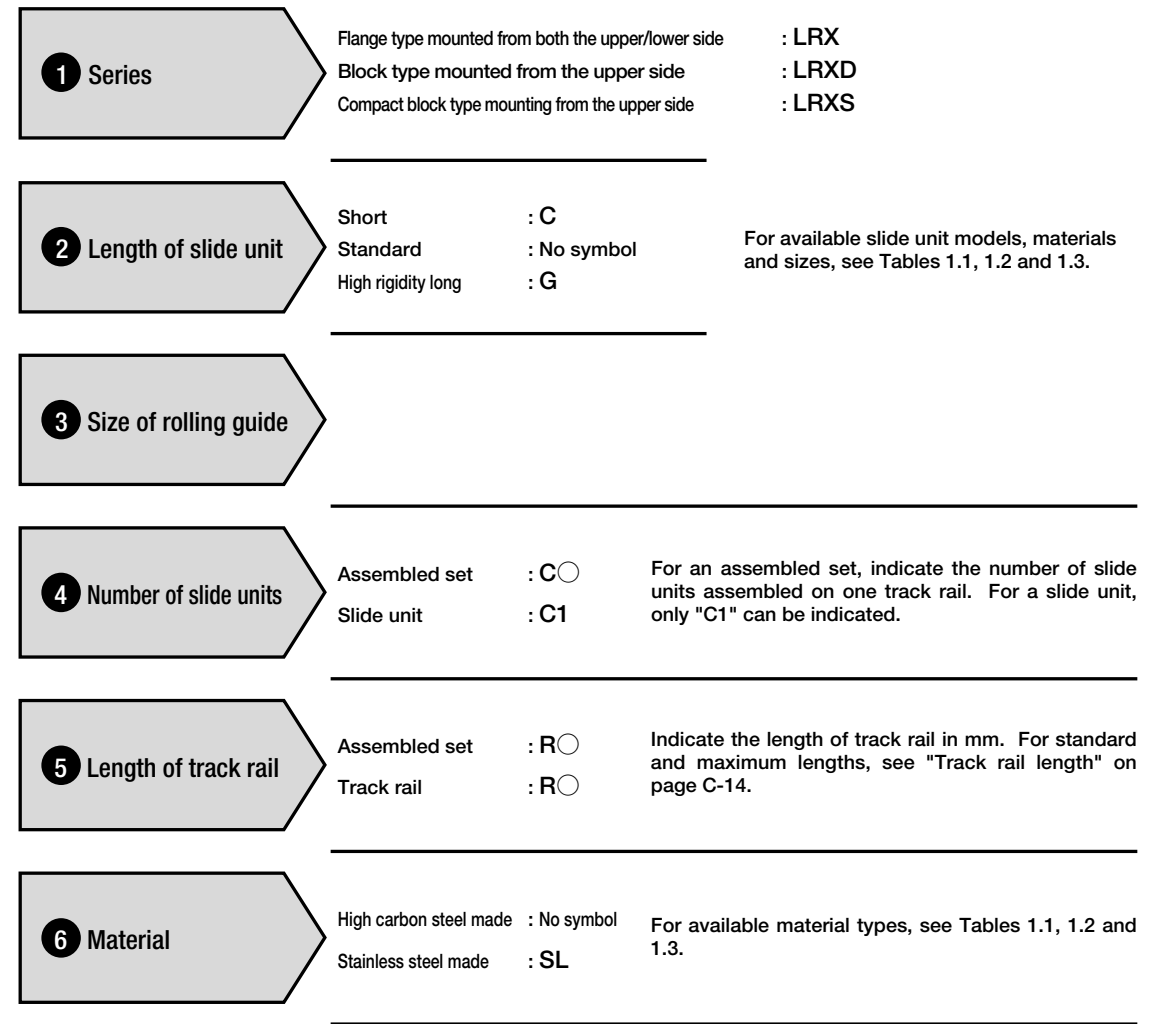

Table 1.1 Models and sizes of Linear Roller Way Super X flange type

Size	Model	High carbon steel made		
		Short LRXC	Standard LRX	High rigidity long LRXG
12		☆	☆	☆
15		☆	☆	☆
20 (1)		☆	☆	☆
25		☆	☆	☆
30		☆	☆	☆
35		☆	☆	☆
45		☆	☆	☆
55		☆	☆	☆
65		☆	☆	☆
85		—	○	○
100		—	—	○

Note(1) : LRXC20, LRX20 and LRXG20 can be mounted from top side only.  
 For mounting from bottom side, LRXHC20, LRXH20 and LRXHG20 can be used, which have the same dimensions as those of the above models.  
 Remark : The mark ☆ indicates that interchangeable specification products are available.

Table 1.2 Models and sizes of Linear Roller Way Super X block type

Size	High carbon steel made			Stainless steel made		
	Short LRXDC	Standard LRXD	High rigidity long LRXDG	Short LRXDC...SL	Standard LRXD...SL	High rigidity long LRXDG...SL
10	—	—	—	—	○	—
12	☆	☆	☆	☆	☆	☆
15	☆	☆	☆	☆	☆	☆
20	☆	☆	☆	☆	☆	☆
25	☆	☆	☆	☆	☆	☆
30	☆	☆	☆	☆	☆	☆
35	☆	☆	☆	—	—	—
45	☆	☆	☆	—	—	—
55	☆	☆	☆	—	—	—
65	☆	☆	☆	—	—	—

Remark : The mark ☆ indicates that interchangeable specification products are available.

Table 1.3 Models and sizes of Linear Roller Way Super X Compact block type

Size	High carbon steel made		
	Short LRXSC	Standard LRXS	High rigidity long LRXSG
15	☆	☆	☆
20	☆	☆	☆
25	☆	☆	☆
30	☆	☆	☆

Remark : The mark ☆ indicates that interchangeable specification products are available.

7 Preload amount

Standard : No symbol  
 Light preload : T1  
 Medium preload : T2  
 Heavy preload : T3

Specify this item for an assembled set or a single slide unit.  
 For applicable preload amount, see Table 2. For details of preload amount, see page 86.

Table 2 Applicable preload types

Size	Preload type (Symbol)			
	Standard (No symbol)	Light preload (T1)	Medium preload (T2)	Heavy preload (T3)
10	○	○	—	—
12	☆	☆	○	○
15	☆	☆	☆	○
20	☆	☆	☆	○
25	○	☆	☆	○
30	○	☆	☆	○
35	○	○	☆	☆
45	○	○	☆	☆
55	○	○	☆	☆
65	○	○	☆	☆
85	○	○	○	○
100	○	○	○	○

Remark : The mark ☆ indicates that it is also applicable to interchangeable specification products.

8 Accuracy class

High : H  
 Precision : P  
 Super precision : SP  
 Ultra precision : UP

For applicable accuracy, see Table 3. In case of interchangeable specification products, assemble slide units and track rails of the same class. For details of accuracy, see page 81.

Table 3 Applicable accuracy class

Size	Accuracy(Symbol)			
	High (H)	Precision (P)	Super precision (SP)	Ultra precision (UP)
10	○	○	○	○
12	☆	☆	○	○
15	☆	☆	○	○
20	☆	☆	○	○
25	☆	☆	○	○
30	☆	☆	○	○
35	☆	☆	○	○
45	☆	☆	○	○
55	☆	☆	○	○
65	☆	☆	○	○
85	○	○	○	○
100	○	○	○	○

Remark : The mark ☆ indicates that it is also applicable to interchangeable specification products.

9 Interchangeable code

Interchangeable specification : S2

Specify this item for interchangeable specification products. Assemble track rails and slide units with the interchangeable code.

10 Special specification

For applicable special specifications, see Table 4. When several special specifications are combined, see Table 5. For details of special specifications, see page 88.

Table 4 Special specifications

Optional specification	Supplemental code	Interchangeable specification			Non-interchangeable specification
		Slide unit	Track rail	Assembled set	
Butt-jointing track rails	/A	—	—	—	○
Opposite reference surfaces arrangement	/D	—	—	○	○
Specified rail mounting hole positions	/E	—	○	○	○
Caps for rail mounting holes	/F	—	○	○	○ <sup>(2)</sup>
Changed pitch of slide unit middle mounting holes	/GE	○ <sup>(1)(3)</sup>	—	○ <sup>(1)(3)</sup>	○ <sup>(1)(2)(3)(4)</sup>
Half pitch of track rail mounting holes	/HP	—	○	○	○ <sup>(2)(5)</sup>
Inspection sheet	/I	—	—	—	○
Female threads for bellows	/JO	○ <sup>(3)(6)</sup>	○ <sup>(3)(6)</sup>	○ <sup>(3)(6)</sup>	○ <sup>(2)(3)(5)</sup>
Black chrome surface treatment	/LO	—	—	○	○ <sup>(2)(4)(5)</sup>
Fluorine black chrome surface treatment	/LFO	—	—	○	○ <sup>(2)(4)(5)</sup>
Without track rail mounting bolts	/MN	—	○	○	○
No end seal	/N	○ <sup>(7)</sup>	—	○ <sup>(7)</sup>	○ <sup>(7)</sup>
Rail cover plate for track rail	/PS	—	—	—	○ <sup>(8)</sup>
Capillary plates	/Q	○	—	○	○ <sup>(5)</sup>
Butt-jointing interchangeable track rail	/T	—	○	○	—
Double end seals	/VO	○	—	○	○ <sup>(2)</sup>
Matched sets to be used as an assembled group	/WO	—	—	—	○ <sup>(4)(5)</sup>
Specified grease	/YO	—	—	○	○
Scrapers	/ZO	○	—	○	○ <sup>(2)</sup>

Note<sup>(1)</sup> : Applicable to LRX, LRXG, LRXH20 and LRXHG20.  
<sup>(2)</sup> : Not applicable to size 10 models.(LRXD10...SL)  
<sup>(3)</sup> : Not applicable to size 12 models.  
<sup>(4)</sup> : Not applicable to size 85 models.

<sup>(5)</sup> : Not applicable to size 100 models.  
<sup>(6)</sup> : Not applicable to stainless steel models.  
<sup>(7)</sup> : Not applicable to size 55,65,85 and 100 models.  
<sup>(8)</sup> : Applicable to size 35, 45 and 55 models.

Table 5 Combination of special specifications

D	○																			
E	—	—																		
F	○	☆	☆																	
GE	○	☆	☆	☆																
HP	—	☆	—	☆	☆															
I	○	○	○	○	○	○														
J	○	☆	☆	☆	☆	—	○													
L	○	☆	☆	☆	☆	☆	○	☆												
LF	○	☆	☆	☆	☆	☆	○	☆	—											
MN	○	☆	☆	☆	☆	☆	○	☆	☆	☆										
N	○	☆	☆	—	☆	☆	○	—	☆	☆	☆									
PS	—	○	○	—	○	○	○	○	—	—	○	—								
Q	○	☆	☆	☆	☆	☆	○	—	☆	☆	☆	☆	○							
T	—	☆	☆	☆	☆	☆	—	—	☆	☆	☆	☆	—	☆						
V	○	☆	☆	☆	☆	☆	○	★	☆	☆	☆	—	○	—	☆					
W	○	○	—	○	○	○	○	○	○	○	○	○	○	○	—	○				
Y	○	☆	☆	☆	☆	☆	○	☆	☆	☆	☆	☆	○	—	☆	☆	○			
Z	○	☆	☆	☆	☆	☆	○	★	☆	☆	☆	—	—	—	☆	★	○	☆		
	A	D	E	F	GE	HP	I	J	L	LF	MN	N	PS	Q	T	V	W	Y		

Remark 1 : The mark ○ indicates that the combination can be made.  
 2 : The mark ☆ indicates that interchangeable specification products are available.  
 3 : The mark — indicates that this combination cannot be made.  
 4 : If the ★ marks are required, please consult IKO.  
 5 : If a combination of special specifications is required, indicate the supplemental codes in alphabetical order.

Table 6 Pitch of slide unit middle mounting holes (Supplemental code /GE)

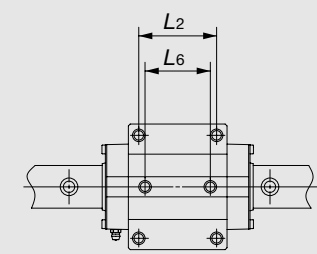

Model number	L2	L6
LRX (G) 15	30	26
LRX (G) 20 <sup>(1)</sup>	40	35
LRX (G) 25	45	40
LRX (G) 30	52	44
LRX (G) 35	62	52
LRX (G) 45	80	60
LRX (G) 55	95	70
LRX (G) 65	110	82
LRXG 100	200	150

Note<sup>(1)</sup> : Also applicable to LRXH(G)20 models that are mounted from bottom.

LRX, LRXD, LRXS

Table 7 Slide unit with capillary plates (Supplemental code /Q), with double end seals (Supplemental code /V), and with scrapers (Supplemental code /Z)

Size : 10, 12, 15, 20, 25, 30

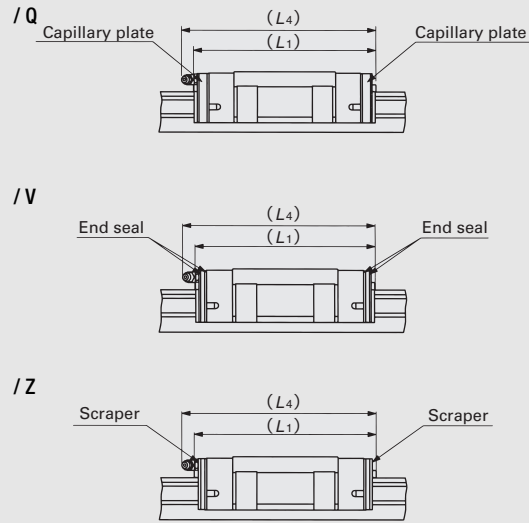

Size : 35, 45, 55, 65, 85, 100

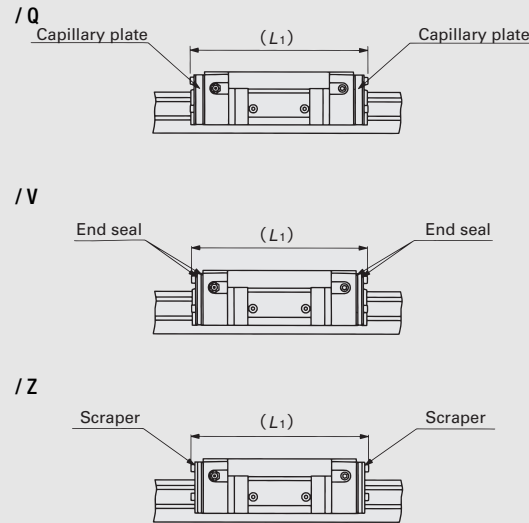

Model number	With capillary plates (✓/Q)		With double end seals <sup>(1)</sup> (✓/V)		With scrapers <sup>(1)</sup> (✓/Z)		Model number	With capillary plates (✓/Q)		With double end seals <sup>(1)</sup> (✓/V)		With scrapers <sup>(1)</sup> (✓/Z)	
	L <sub>1</sub>	L <sub>4</sub>	L <sub>1</sub>	L <sub>4</sub>	L <sub>1</sub>	L <sub>4</sub>		L <sub>1</sub>	L <sub>4</sub>	L <sub>1</sub>	L <sub>4</sub>	L <sub>1</sub>	L <sub>4</sub>
	LRXD 10...SL	43.5	—	—	—	—		—	LRXC 35	103	101	103	—
LRXC 12	47	50	44	46	45	48	LRX 35	135	133	135	—	—	—
LRX 12	57	60	54	57	56	58	LRXG 35	163	161	163	—	—	—
LRXG 12	68	71	65	67	66	69	LRXC 45	127	127	129	—	—	—
LRXC 15	63	64	58	60	60	61	LRX 45	167	167	169	—	—	—
LRX 15	79	80	74	76	76	77	LRXG 45	207	207	209	—	—	—
LRXG 15	95	96	90	92	92	93	LRXC 55	149	149	151	—	—	—
LRXC 20	76	85	73	83	75	84	LRX 55	197	197	199	—	—	—
LRX 20	96	105	93	103	95	104	LRXG 55	251	251	253	—	—	—
LRXG 20	116	125	113	123	115	124	LRXC 65	198	193	194	—	—	—
LRXC 25	85	94	83	92	85	93	LRX 65	262	257	258	—	—	—
LRX 25	109	118	107	116	109	117	LRXG 65	326	321	322	—	—	—
LRXG 25	124	133	122	131	124	132	LRX 85	341	338	339	—	—	—
LRXC 30	96	108	93	106	96	107	LRXG 85	413	410	411	—	—	—
LRX 30	124	136	121	134	124	135	LRXG 100	—	376	378	—	—	—
LRXG 30	145	157	142	155	145	156							

Note<sup>(1)</sup> : The values for a slide unit with double end seals or scrapers at both ends are shown  
 Remark : The above table shows representative model numbers and is also applicable to all models in the same size.

Table 8.1 Female threads for bellows (Supplemental code /J)

Size : 15, 20, 25, 30

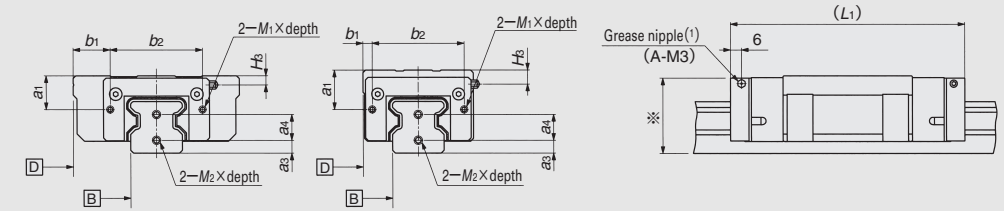

Model number	Slide unit						Track rail		
	a <sub>1</sub>	b <sub>1</sub>	b <sub>2</sub>	M <sub>1</sub> × depth	L <sub>1</sub> (3)	H <sub>b</sub>	a <sub>3</sub>	a <sub>4</sub>	M <sub>2</sub> × depth
LRXC 15	10.5	10.5	26	M3X6	67	1	4	8	M3X6
LRX 15					83				
LRXG 15					99				
LRXD 15	14.5	4	26	M3X6	67	5	4	8	M3X6
LRXD 15					83				
LRXDC 15					99				
LRXSC 15	10.5	4	26	M3X6	67	1	4	8	M3X6
LRXS 15					83				
LRXSG 15					99				
LRXC 20 <sup>(2)</sup>	12	13.5	36	M3X6	81	2	5	10	M4X8
LRX 20 <sup>(2)</sup>					101				
LRXG 20 <sup>(2)</sup>					121				
LRXD 20	16	4	36	M3X6	81	6	5	10	M4X8
LRXD 20					101				
LRXDC 20					121				
LRXSC 20	12	4	36	M3X6	81	2	5	10	M4X8
LRXS 20					101				
LRXSG 20					121				
LRXC 25	15.5	15	40	M3X6	89	4	6	12	M4X8
LRX 25					113				
LRXG 25					128				
LRXD 25	19.5	4	40	M3X6	89	8	6	12	M4X8
LRXD 25					113				
LRXDC 25					128				
LRXSC 25	15.5	4	40	M3X6	89	4	6	12	M4X8
LRXS 25					113				
LRXSG 25					128				
LRXC 30	18.5	20	50	M3X6	100	4.8	7	14	M4X8
LRX 30					128				
LRXG 30					149				
LRXD 30	21.5	5	50	M3X6	100	7.8	7	14	M4X8
LRXD 30					128				
LRXDC 30					149				
LRXSC 30	18.5	5	50	M3X6	100	4.8	7	14	M4X8
LRXS 30					128				
LRXSG 30					149				

Note<sup>(1)</sup> : The specification and mounting position of grease nipple are different from those of the standard specification product. The grease nipple of the size 30 models is A-M4. For grease nipple specifications, see Table 12.

<sup>(2)</sup> : Also applicable to LRXHC 20, LRXH 20 and LRXHG 20.

<sup>(3)</sup> : The values for a slide unit with female threads for bellows at both ends are shown.

Remark : For the size 15 and 20 models of flange type and compact block type, the dimension "※" is higher than the dimension H of the assembly. For details, consult IJKO for further information.

Table 8.2 Female threads for bellows (Supplemental code /J)

Size : 35, 45, 55, 65, 85

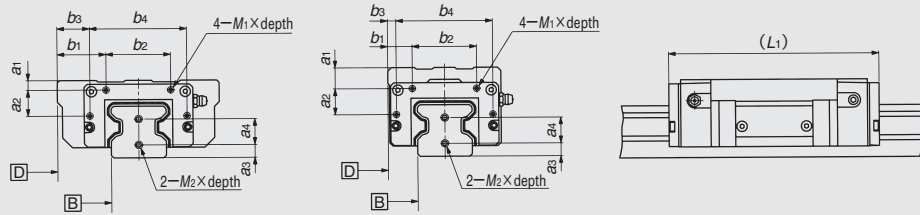

Model number	Slide unit								Track rail		
	a <sup>1</sup>	a <sup>2</sup>	b <sub>1</sub>	b <sub>2</sub>	b <sub>3</sub>	b <sub>4</sub>	M <sub>1</sub> X depth	L <sub>1</sub> (1)	a <sup>3</sup>	a <sup>4</sup>	M <sub>2</sub> X depth
LRXC 35	6	16	30	40	20	60	M3X 6	99	8	16	M4X 8
LRX 35								131			
LRXG 35								159			
LRXDC 35								99			
LRXD 35								131			
LRXDG 35	159										
LRXC 45	7	21	35	50	23	74	M4X 8	123	10	19	M5X10
LRX 45								163			
LRXG 45								203			
LRXDC 45								123			
LRXD 45								163			
LRXDG 45	203										
LRXC 55	7	27	40	60	26	88	M4X 8	145	10	24	M5X10
LRX 55								193			
LRXG 55								247			
LRXDC 55								145			
LRXD 55								193			
LRXDG 55	247										
LRXC 65	8.7	37	47.5	75	31	108	M5X10	192	14	28	M6X12
LRX 65								256			
LRXG 65								320			
LRXDC 65								192			
LRXD 65								256			
LRXDG 65	320										
LRX 85	15	45	62.5	90	37.5	140	M6X10	334	14.5	38	M6X12
LRXG 85								406			

Note(1) : The values for the slide units with female threads for bellows at the both ends.

### ● Mounting slide unit of Compact block type

For mounting slide unit of Compact block type, insertion depth shown in Table 9 is recommended to keep certain fixing strength.

Table 9 Insertion depths for mounting Compact block type slide unit

unit : mm	
Model number	Recommended screw-in depths
LRXS 15	4.5
LRXS 20	5.5
LRXS 25	7
LRXS 30	9

Remark : The table shows representative model number but is applicable to all models of the same size.

## Track rail length

Standard and maximum lengths of track rails are shown in Tables 10.1 and 10.2. Track rails in any length are also available. Simply indicate the necessary length of track rail in mm in the identification number. For the tolerances of *E* dimension and track rail length, consult **IICO** for further information.

- For non-interchangeable track rails longer than the maximum length shown in Tables 10.1 and 10.2, butt-jointing track rails are available upon request. In this case, indicate "/A" in the identification number.
- *E* dimensions at both ends are the same and are within the standard range of *E* unless otherwise specified. To change these dimensions, specify the specified rail mounting hole positions "/*E*" of special specification. For details, see page 88.

Table 10.1 Standard and maximum lengths of high carbon steel track rails

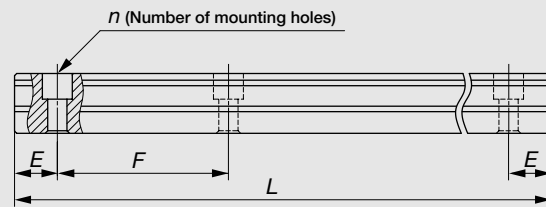

unit : mm

Model number	LRX 12	LRX 15	LRX 20	LRX 25	LRX 30	LRX 35
Pitch of mounting holes <i>F</i>	40	60	60	60	80	80
<i>E</i>	20	30	30	30	40	40
Standard range of <i>E</i> <sup>(1)</sup>	incl.	5.5	7	8	9	10
	under	25.5	37	38	39	50
Maximum length <sup>(2)</sup>	1 480	1 500 (1 980)	1 980 (3 000)	3 000	2 960 (4 000)	2 960 (4 000)

Model number	LRX 45	LRX 55	LRX 65	LRX 85	LRXG 100	
Pitch of mounting holes <i>F</i>	105	120	150	180	150	
<i>E</i>	52.5	60	75	90	75	
Standard range of <i>E</i> <sup>(1)</sup>	incl.	12.5	15	17	23	29
	under	65	75	92	113	104
Maximum length <sup>(2)</sup>	2 940 (3 990)	3 000 (3 960)	3 000 (3 900)	2 880 <sup>(3)</sup>	3 000	

Note<sup>(1)</sup> : Not applicable to the track rail with female threads for bellows (supplemental code "/J").

<sup>(2)</sup> : Track rails with the maximum lengths shown in parentheses can also be manufactured. Consult **IICO** for further information.

<sup>(3)</sup> : For half pitch of track rail mounting holes (supplemental code "/HP"), the maximum length is 2970mm.

Remark : The above table shows representative model numbers but is applicable to all models of the same size.

Table 10.2 Standard and maximum lengths of stainless steel track rails

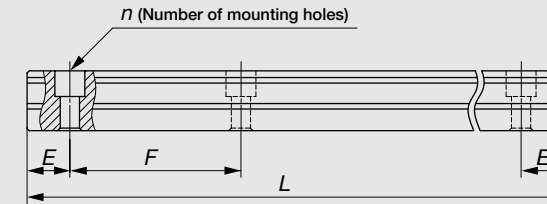

unit : mm

Model number	LRXD 10...SL	LRX 12...SL	LRX 15...SL	LRX 20...SL	LRX 25...SL	LRX 30...SL
Pitch of mounting holes <i>F</i>	25	40	60	60	60	80
<i>E</i>	12.5	20	30	30	30	40
Standard range of <i>E</i> <sup>(1)</sup>	incl.	5	5.5	7	8	9
	under	17.5	25.5	37	38	39
Maximum length <sup>(2)</sup>	850 (1 000)	1 000 (1 480)	1 200 (1 980)	1 200 (1 980)	1 200 (1 980)	1 200 (2 000)

Note<sup>(1)</sup> : Not applicable to the track rail with female threads for bellows (supplemental code "/J").

<sup>(2)</sup> : Track rails with the maximum lengths shown in parentheses can also be manufactured. Consult **IICO** for further information.

Remark : The above table shows representative model numbers and is also applicable to all stainless steel track rails in the same size.

## Rigidity of Linear Roller Way Super X (Reference Values)

Linear Roller Way Super X has the highest rigidity among all the Linear Way and Linear Roller Way series. Deflection due to elastic deformations at the contact area of the rolling element and in the structural members under external load is very small. Typical experimental data on the relations between the load and the deflection for various preload amounts and load directions are shown below as reference values.

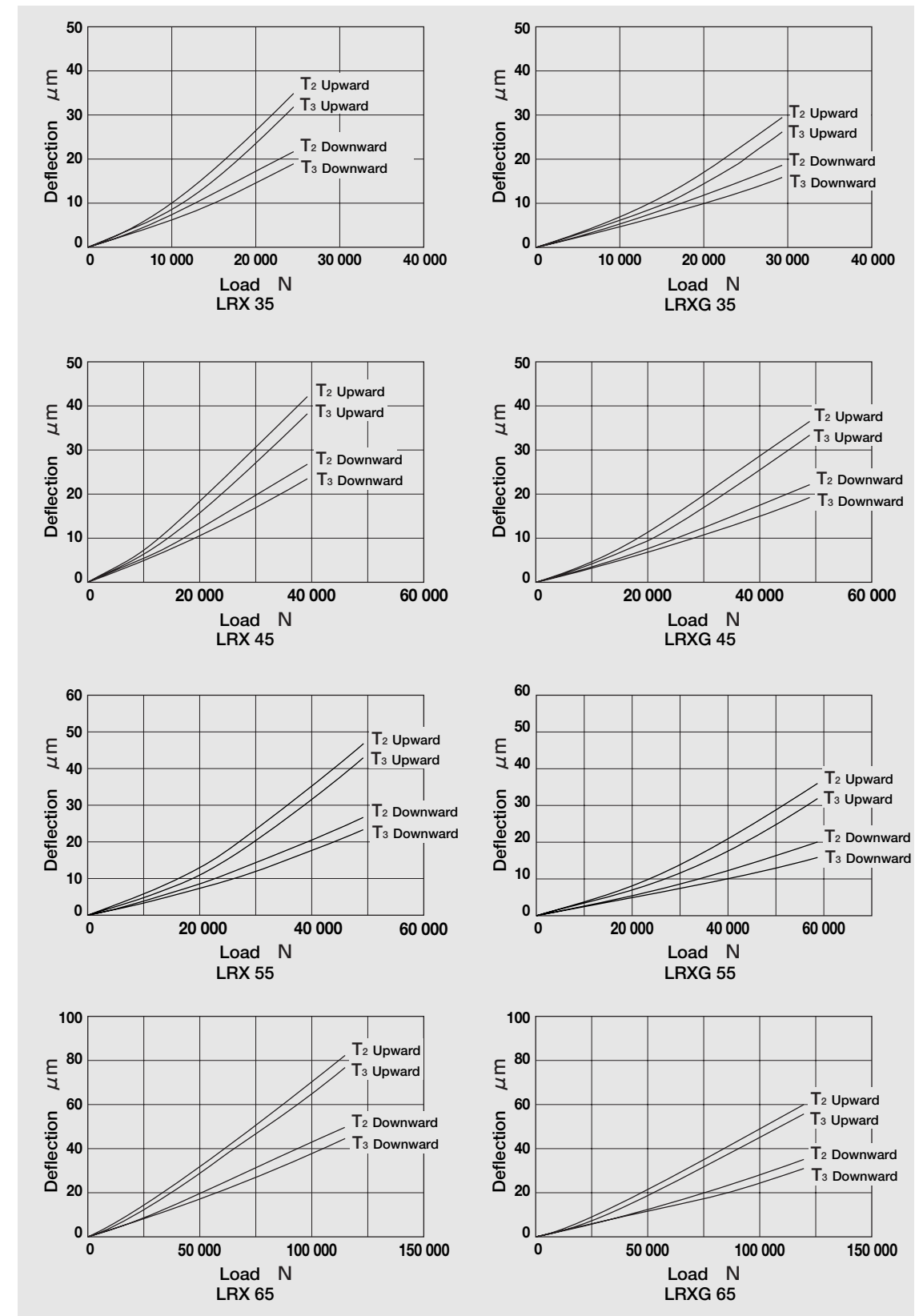
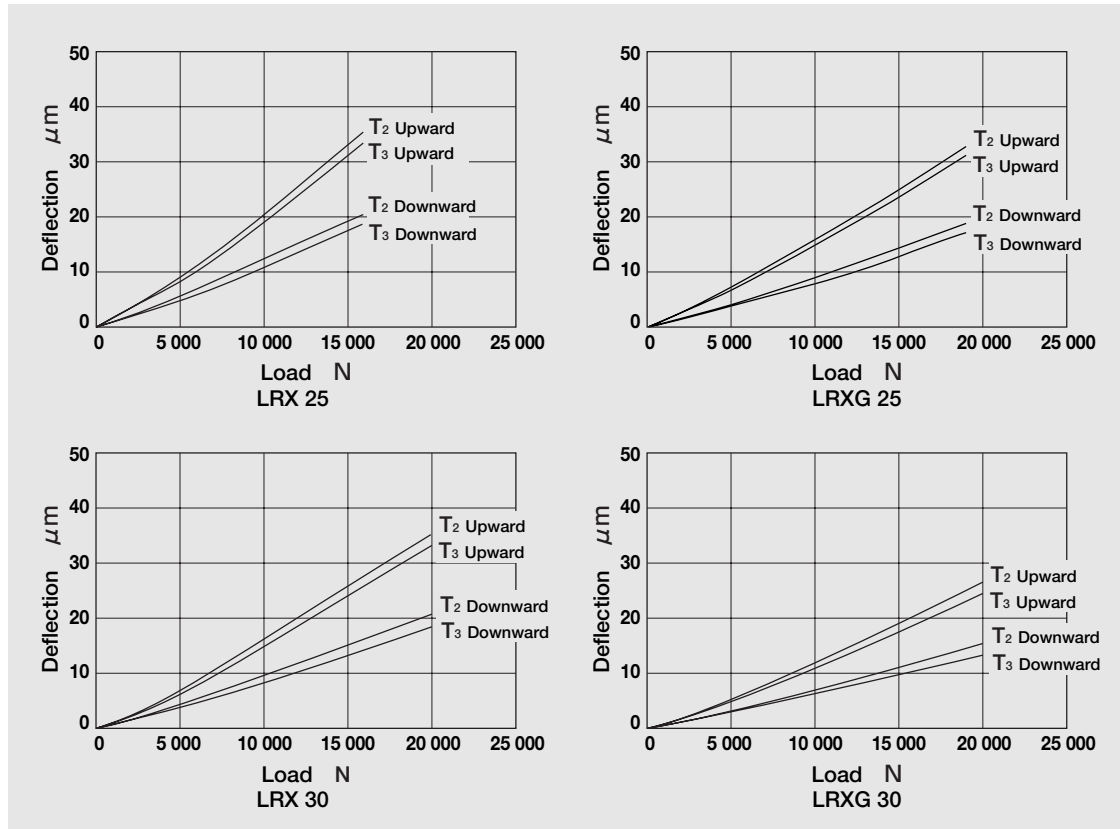
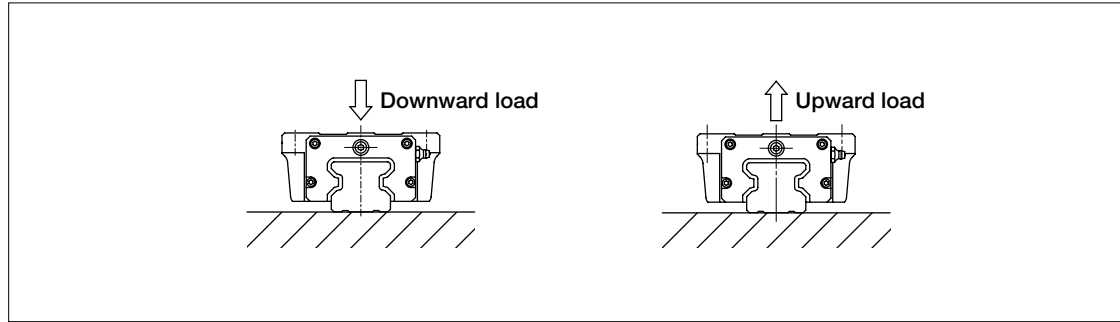



Flange type mounted from top/bottom  
LRXC, LRX, LRXG

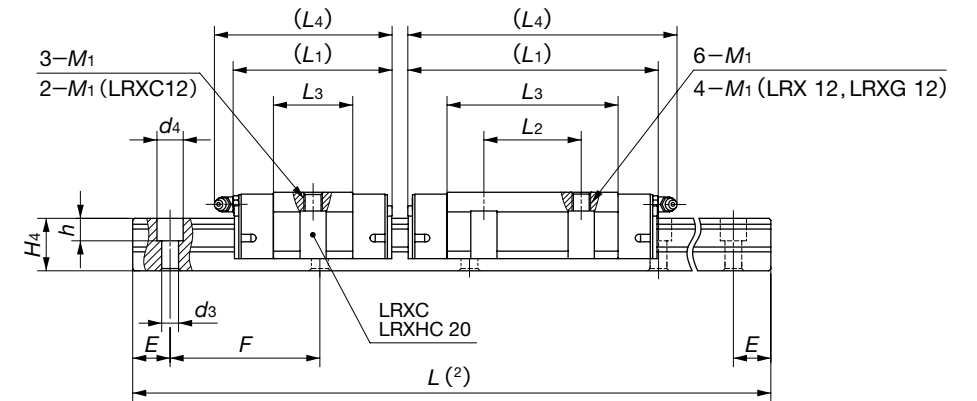
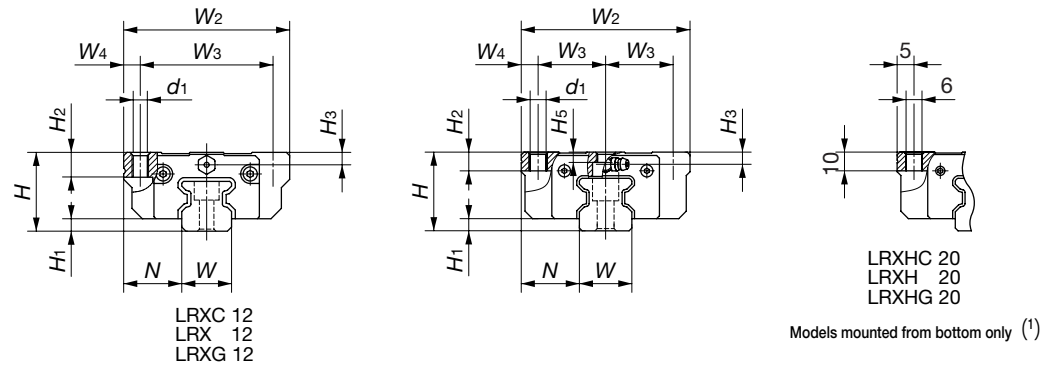

Model number	Interchangeable	Mass (Ref.)		Dimensions of assembly mm			Dimensions of slide unit mm										
		Slide unit kg	Track rail kg/m	H	H <sub>1</sub>	N	W <sub>2</sub>	W <sub>3</sub>	W <sub>4</sub>	L <sub>1</sub>	L <sub>2</sub>	L <sub>3</sub>	L <sub>4</sub>	d <sub>1</sub>	M <sub>1</sub>	H <sub>2</sub>	
LRXC 12	☆	0.058							37	—	14.8	40					
LRX 12	☆	0.092	0.92	19	3	14	40	32	4	47	15	25.3	50	3.4	M 4	6	
LRXG 12	☆	0.13								58		35.8	61				
LRXC 15	☆	0.13							52	—	24	55					
LRX 15	☆	0.20	1.65	24	4	16	47	19	4.5	68	30	40	71	4.4	M 5	7	
LRXG 15	☆	0.28								84		56	87				
LRXC 20 (1)	☆	0.29							66	—	31.6	74		(1)	(1)		
LRX 20 (1)	☆	0.44	2.73	30	5	21.5	63	26.5	5	86	40	51.6	94	—	M 6	10	
LRXG 20 (1)	☆	0.61								106		71.6	114				
LRXC 25	☆	0.44							74	—	36	83					
LRX 25	☆	0.67	3.59	36	6	23.5	70	28.5	6.5	98	45	60	107	7	M 8	10	
LRXG 25	☆	0.84								113		75	122				
LRXC 30	☆	0.78							85	—	42.4	95					
LRX 30	☆	1.20	5.01	42	6.5	31	90	36	9	113	52	70.4	123	8.5	M10	10	
LRXG 30	☆	1.58								134		91.4	144				

Note(1) : LRXC20, LRX20 and LRXG20 can be mounted from the upper side only. For mounting from the lower side, LRXHC20, LRXH20 and LRXHG20 which have the same dimensions as those of the above models can be used.

(2) : Track rail lengths are shown in Table 10.1 on page C-14.

(3) : The directions of basic dynamic load rating (C), basic static load rating (C<sub>0</sub>) and static moment rating (T<sub>0</sub>, T<sub>x</sub>, T<sub>y</sub>) are shown in the sketches below. The upper values in the T<sub>x</sub> and T<sub>y</sub> columns apply to one slide unit, and the lower values apply to two slide units in close contact.

Remark 1 : The mark ☆ indicates that interchangeable specification products are available.

2 : The appended track rail mounting bolts are hexagon socket head bolts of JIS B 1176 or equivalent.

3 : For grease nipple specifications, see page 99.

4 : A grease nipple mounting thread hole is provided on the left and right end plates respectively.

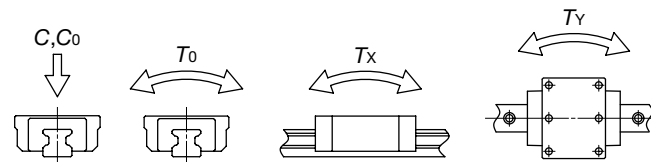

H <sub>3</sub>	H <sub>5</sub>	Dimensions of track rail mm							Mounting bolt for track rail mm Bolt size × length	Basic dynamic load rating <sup>(3)</sup> C N	Basic static load rating <sup>(3)</sup> C <sub>0</sub> N	Static moment rating <sup>(3)</sup>		
		W	H <sub>4</sub>	d <sub>3</sub>	d <sub>4</sub>	h	E	F				T <sub>0</sub> N·m	T <sub>x</sub> N·m	T <sub>y</sub> N·m
3	—	12	12	3.5	6	4.5	20	40	M3×12	3 900	6 090	46.3	16.3 170	16.3 170
										5 890	10 400	78.7	45.2 343	45.2 343
										7 710	14 600	111	88.6 581	88.6 581
3.5	3	15	16.5	4.5	8	6	30	60	M4×16	7 730	12 000	113	50.6 457	50.6 457
										11 500	20 000	188	136 942	136 942
										14 900	28 000	263	262 1 590	262 1 590
4	3.5	20	21	6	9.5	8.5	30	60	M5×20	16 100	26 400	341	150 1 260	150 1 260
										23 400	42 700	550	379 2 520	379 2 520
										30 100	58 900	760	713 4 200	713 4 200
5	5	23	24.5	7	11	9	30	60	M6×25	21 600	33 800	500	213 1 810	213 1 810
										32 100	56 300	833	573 3 800	573 3 800
										38 200	70 300	1 040	885 5 380	885 5 380
6.5	5.5	28	28	9	14	12	40	80	M8×28	29 200	44 600	808	329 2 740	329 2 740
										43 400	74 400	1 350	883 5 780	883 5 780
										53 200	96 700	1 750	1 470 8 740	1 470 8 740

Example of identification number of assembled set (For details, see "Identification number and specification".)

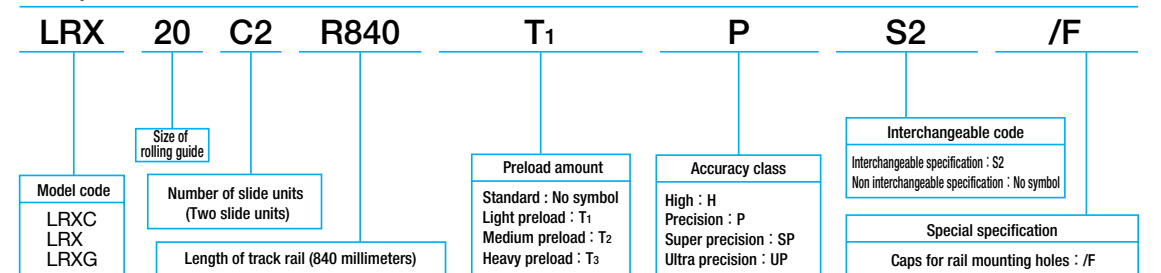

# IKO Linear Roller Way Super X : Flange type

Flange type mounted from top/bottom  
LRXC, LRX, LRXG

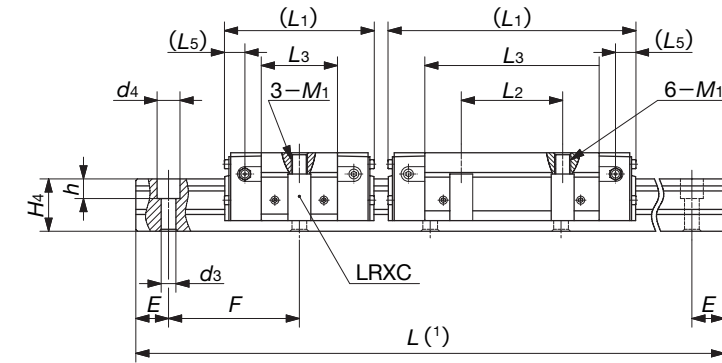
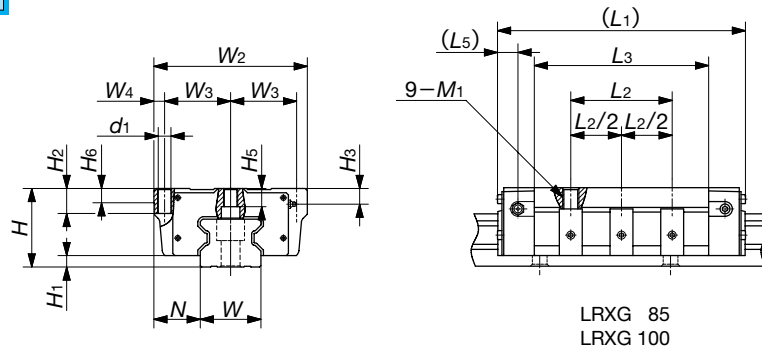

Model number	Interchangeable	Mass (Ref.)		Dimensions of assembly mm			Dimensions of slide unit mm										
		Slide unit kg	Track rail kg/m	H	H <sub>1</sub>	N	W <sub>2</sub>	W <sub>3</sub>	W <sub>4</sub>	L <sub>1</sub>	L <sub>2</sub>	L <sub>3</sub>	L <sub>5</sub>	d <sub>1</sub>	M <sub>1</sub>	H <sub>2</sub>	H <sub>3</sub>
LRXC 35	☆	1.13	6.88	48	6.5	33	100	41	9	92	—	46.6	12.5	8.5	M10	13	13
LRX 35	☆	1.76								124	62	78.6					
LRXG 35	☆	2.41								152	106.6						
LRXC 45	☆	2.11	10.8	60	8	37.5	120	50	10	114	—	59	17.5	10.5	M12	15	16
LRX 45	☆	3.26								154	80	99					
LRXG 45	☆	4.60								194	139						
LRXC 55	☆	3.49	14.1	70	9	43.5	140	58	12	136	—	72	20	12.5	M14	17	16
LRX 55	☆	5.42								184	95	120					
LRXG 55	☆	7.93								238	174						
LRXC 65	☆	7.18	22.6	90	12	53.5	170	71	14	181	—	95	26.6	14.5	M16	23	18
LRX 65	☆	11.5								245	110	159					
LRXG 65	☆	16.0								309	223						
LRX 85		25.4	36.7	110	16	65	215	92.5	15	323	140	232	27.5	17.8	M20	35	22
LRXG 85		32.7								395	200	304					
LRXG 100		43.0	43.2	120	15	75	250	110	15	362	200	262	29.7	17.8	M20	35	30

H <sub>5</sub>	H <sub>6</sub>	Dimensions of track rail mm							Mounting bolt for track rail mm Bolt size × length	Basic dynamic load rating <sup>(2)</sup> C N	Basic static load rating <sup>(2)</sup> C <sub>0</sub> N	Static moment rating <sup>(2)</sup>		
		W	H <sub>4</sub>	d <sub>3</sub>	d <sub>4</sub>	h	E	F				T <sub>0</sub> N·m	T <sub>X</sub> N·m	T <sub>Y</sub> N·m
7	—	34	32	9	14	12	40	80	M 8×35	39 500	60 000	1 300	506	506
										58 700	100 000	2 170	1 360	1 360
										74 200	135 000	2 930	2 440	2 440
11	—	45	38	14	20	17	52.5	105	M12×40	64 100	95 600	2 660	1 010	1 010
										95 400	159 000	4 430	2 700	2 700
										124 000	223 000	6 200	5 220	5 220
14	—	53	43	16	23	20	60	120	M14×45	99 700	149 000	4 830	1 880	1 880
										148 000	248 000	8 040	5 040	5 040
										198 000	359 000	11 700	10 400	10 400
18.5	—	63	56	18	26	22	75	150	M16×60	174 000	249 000	9 790	4 200	4 200
										260 000	415 000	16 300	11 300	11 300
										337 000	581 000	22 800	21 800	21 800
25.5	20	85	67	26.5	39	30	90	180	M24×70	440 000	753 000	38 900	29 500	29 500
										542 000	985 000	50 800	50 000	50 000
30.5	—	100	70	33	48	36	75	150	M30×80	498 000	821 000	49 700	35 800	35 800
													199 000	199 000

Note<sup>(1)</sup>: Track rail lengths are shown in Table 10.1 on page C-14.  
<sup>(2)</sup>: The directions of basic dynamic load rating (C), basic static load rating (C<sub>0</sub>) and static moment rating (T<sub>0</sub>, T<sub>X</sub>, T<sub>Y</sub>) are shown in the sketches below. The upper values in the T<sub>X</sub> and T<sub>Y</sub> columns apply to one slide unit, and the lower values apply to two slide units in close contact.  
 Remark 1: The mark ☆ indicates that interchangeable specification products are available.  
 2: The appended track rail mounting bolts are hexagon socket head bolts of JIS B 1176 or equivalent.  
 3: For grease nipple specifications, see page 99.  
 4: Three grease nipple mounting thread holes are provided on the left and right end plates respectively.

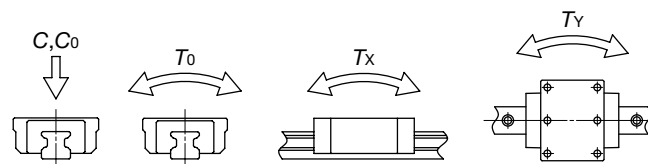

Example of identification number of assembled set (For details, see "Identification number and specification".)

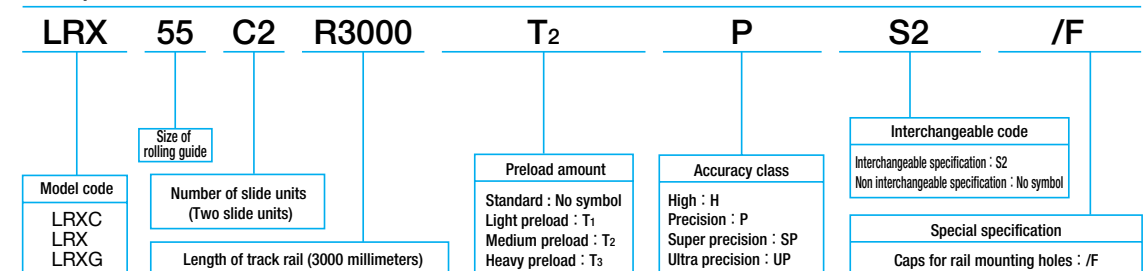

**Block type mounted from top**  
**LRXDC, LRXD, LRXDG**  
**LRXDC...SL** (Stainless steel made)  
**LRXD ...SL** (Stainless steel made)  
**LRXDG...SL** (Stainless steel made)

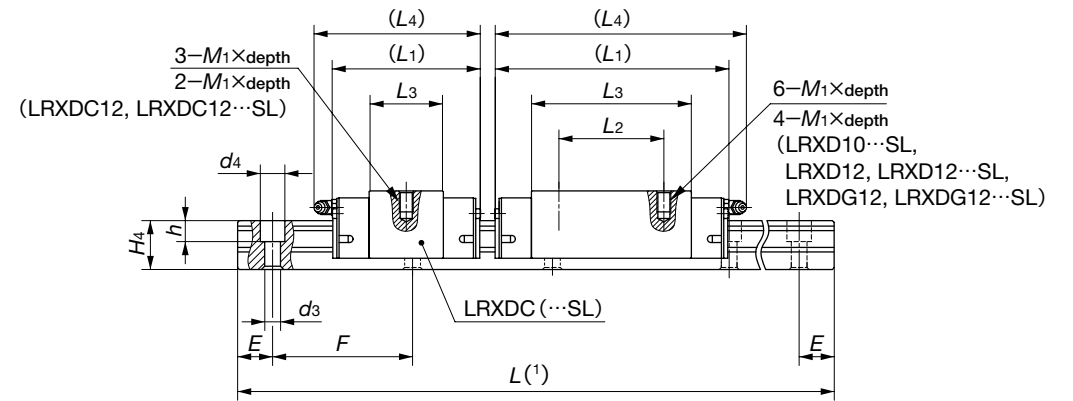
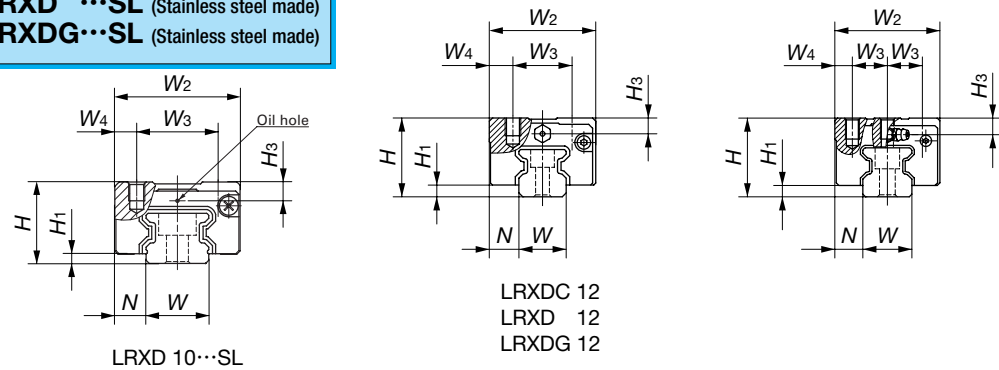

Model number	Interchangeable	Mass (Ref.)		Dimensions of assembly mm			Dimensions of slide unit mm								
		Slide unit kg	Track rail kg/m	H	H <sub>1</sub>	N	W <sub>2</sub>	W <sub>3</sub>	W <sub>4</sub>	L <sub>1</sub>	L <sub>2</sub>	L <sub>3</sub>	L <sub>4</sub>	M <sub>1</sub> ×depth	H <sub>3</sub>
LRXD 10...SL		0.028	0.48	13	1.5	5	20	13	3.5	34.5	12	21.5	—	M2.6×3	3
LRXDC 12	☆	0.045								37	—	14.8	40		
LRXDC 12...SL	☆														
LRXD 12	☆	0.072	0.92	20	3	7.5	27	15	6	47	15	25.3	50	M4 ×4.5	4
LRXD 12...SL	☆														
LRXDG 12	☆	0.097								58		35.8	61		
LRXDG 12...SL	☆														
LRXDC 15	☆	0.13								52	—	24	55		
LRXDC 15...SL	☆														
LRXD 15	☆	0.19	1.65	28	4	9.5	34	13	4	68	26	40	71	M4 ×8	7.5
LRXD 15...SL	☆														
LRXDG 15	☆	0.26								84		56	87		
LRXDG 15...SL	☆														

Dimensions of track rail mm							Mounting bolt for track rail mm Bolt size × length	Basic dynamic load rating <sup>(2)</sup> C N	Basic static load rating <sup>(2)</sup> C <sub>0</sub> N	Static moment rating <sup>(2)</sup>		
W	H <sub>4</sub>	d <sub>3</sub>	d <sub>4</sub>	h	E	F				T <sub>0</sub> N·m	T <sub>x</sub> N·m	T <sub>y</sub> N·m
10	8	3.5	6	3.5	12.5	25	M3×10	3 160	6 190	39.6	23.0 146	23.0 146
12	12	3.5	6	4.5	20	40	M3×12	5 890	10 400	78.7	45.2 343	45.2 343
								7 710	14 600	111	88.6 581	88.6 581
15	16.5	4.5	8	6	30	60	M4×16	7 730	12 000	113	50.6 457	50.6 457
								11 500	20 000	188	136 942	136 942
								14 900	28 000	263	262 1 590	262 1 590

Note(1) : Track rail lengths are shown in Table 10.1 on page C-14 and Table 10.2 on page C-15.  
 (2) : The directions of basic dynamic load rating (C), basic static load rating (C<sub>0</sub>) and static moment rating (T<sub>0</sub>, T<sub>x</sub>, T<sub>y</sub>) are shown in the sketches below. The upper values in the T<sub>x</sub> and T<sub>y</sub> columns apply to one slide unit, and the lower values apply to two slide units in close contact.  
 Remark 1 : The mark ☆ indicates that interchangeable specification products are available.  
 2 : The appended track rail mounting bolts are hexagon socket head bolts of JIS B 1176 or equivalent. For stainless steel type Linear Roller Way Super X, stainless steel bolts are appended.  
 3 : For grease nipple specifications, see page 99.  
 4 : A grease nipple mounting thread hole is provided on the left and right end plates respectively.

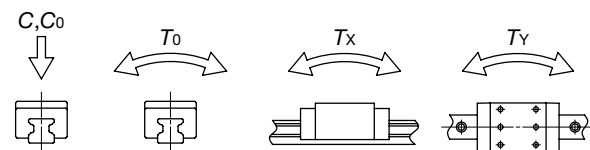

Example of identification number of assembled set (For details, see "Identification number and specification".)

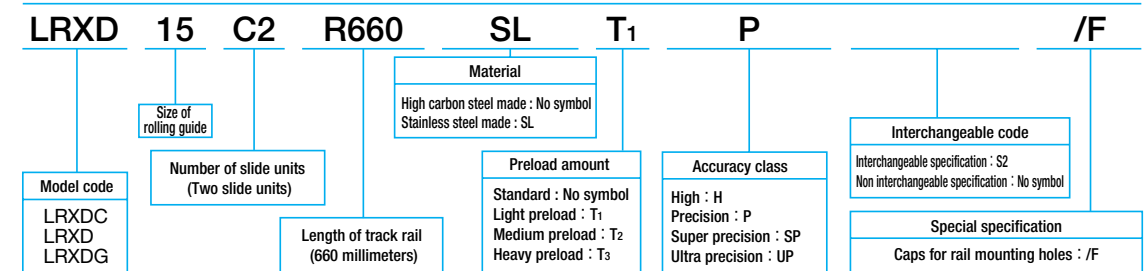

**Block type mounted from top**  
**LRXDC**  
**LRXD**  
**LRXDG**  
**LRXDC...SL** (Stainless steel made)  
**LRXD ...SL** (Stainless steel made)  
**LRXDG...SL** (Stainless steel made)

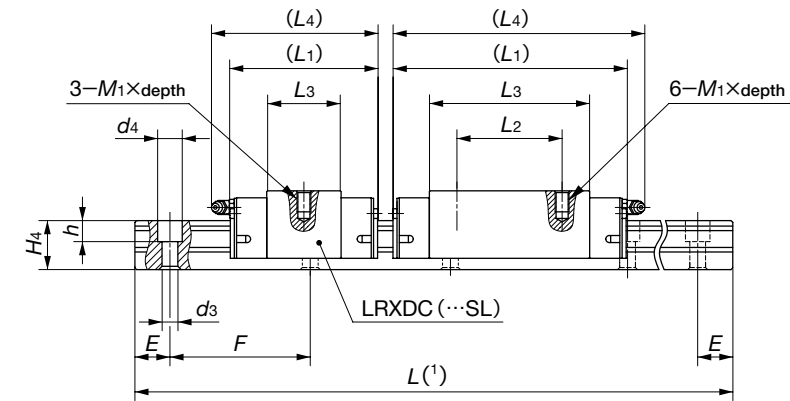
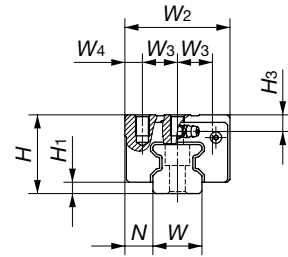

Model number	Interchangeable	Mass (Ref.)		Dimensions of assembly mm			Dimensions of slide unit mm								
		Slide unit kg	Track rail kg/m	H	H <sub>1</sub>	N	W <sub>2</sub>	W <sub>3</sub>	W <sub>4</sub>	L <sub>1</sub>	L <sub>2</sub>	L <sub>3</sub>	L <sub>4</sub>	M <sub>1</sub> ×depth	H <sub>3</sub>
LRXDC 20	☆	0.25	2.73	34	5	12	44	16	6	66	—	31.6	74	M5×8	8
LRXDC 20...SL	☆									86	36	51.6	94		
LRXD 20	☆									106	50	71.6	114		
LRXD 20...SL	☆									106	50	71.6	114		
LRXDC 25	☆	0.36	3.59	40	6	12.5	48	17.5	6.5	74	—	36	83	M6×12	9
LRXDC 25...SL	☆									98	35	60	107		
LRXD 25	☆									113	50	75	122		
LRXD 25...SL	☆									113	50	75	122		
LRXDC 30	☆	0.60	5.01	45	6.5	16	60	20	10	85	—	42.4	95	M8×12	9.5
LRXDC 30...SL	☆									113	40	70.4	123		
LRXD 30	☆									134	60	91.4	144		
LRXD 30...SL	☆									134	60	91.4	144		
LRXDC 30	☆	1.18	5.01	45	6.5	16	60	20	10	134	60	91.4	144	M8×12	9.5
LRXDC 30...SL	☆									134	60	91.4	144		
LRXD 30	☆									134	60	91.4	144		
LRXD 30...SL	☆									134	60	91.4	144		

Note(1) : Track rail lengths are shown in Table 10.1 on page C-14 and Table 10.2 on page C-15.

(2) : The directions of basic dynamic load rating (C), basic static load rating (C<sub>0</sub>) and static moment rating (T<sub>0</sub>, T<sub>x</sub>, T<sub>y</sub>) are shown in the sketches below. The upper values in the T<sub>x</sub> and T<sub>y</sub> columns apply to one slide unit, and the lower values apply to two slide units in close contact.

Remark 1 : The mark ☆ indicates that interchangeable specification products are available.

2 : The appended track rail mounting bolts are hexagon socket head bolts of JIS B 1176 or equivalent.

For stainless steel type Linear Roller Way Super X, stainless steel bolts are appended.

3 : For grease nipple specifications, see page 99.

4 : A grease nipple mounting thread hole is provided on the left and right end plates respectively.

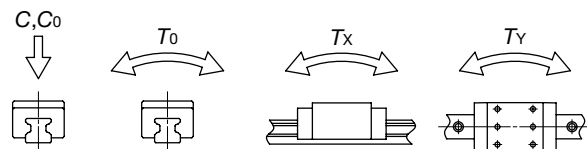

Dimensions of track rail mm							Mounting bolt for track rail mm Bolt size × length	Basic dynamic load rating <sup>(2)</sup> C N	Basic static load rating <sup>(2)</sup> C <sub>0</sub> N	Static moment rating <sup>(2)</sup>		
W	H <sub>4</sub>	d <sub>3</sub>	d <sub>4</sub>	h	E	F				T <sub>0</sub> N·m	T <sub>x</sub> N·m	T <sub>y</sub> N·m
20	21	6	9.5	8.5	30	60	M5×20	16 100	26 400	341	150	150
										550	379	379
										760	713	713
23	24.5	7	11	9	30	60	M6×25	21 600	33 800	500	213	213
										833	573	573
										1 040	885	885
28	28	9	14	12	40	80	M8×28	29 200	44 600	808	329	329
										1 350	883	883
										1 750	1 470	1 470

Example of identification number of assembled set (For details, see "Identification number and specification".)

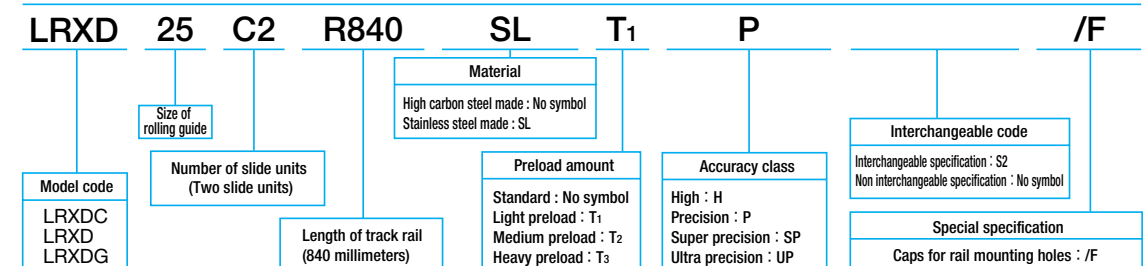

Block type mounted from the upper side  
LRXDC, LRXD, LRXDG

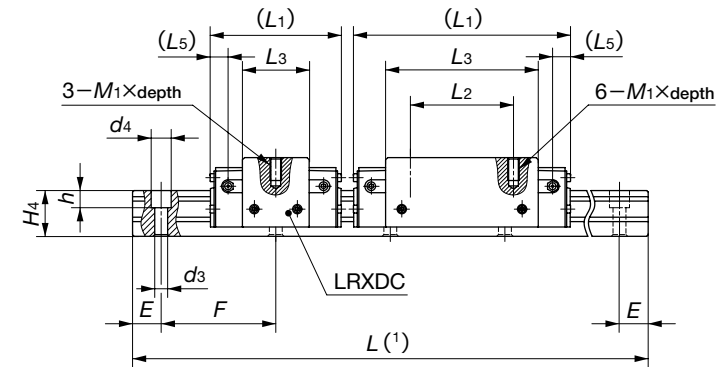
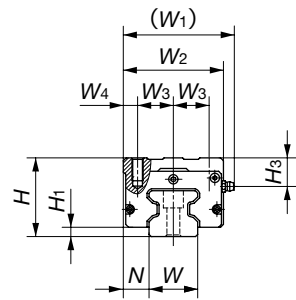

Model number	Interchangeable	Mass (Ref.)		Dimensions of assembly mm			Dimensions of slide unit mm								
		Slide unit kg	Track rail kg/m	H	H <sub>1</sub>	N	W <sub>1</sub>	W <sub>2</sub>	W <sub>3</sub>	W <sub>4</sub>	L <sub>1</sub>	L <sub>2</sub>	L <sub>3</sub>	L <sub>5</sub>	M <sub>1</sub> ×depth
LRXDC 35	☆	0.97	6.88	55	6.5	18	80	70	25	10	92	—	46.6	12.5	M 8×16
LRXD 35	☆	1.52									124	50	78.6		
LRXDG 35	☆	2.02									152	72	106.6		
LRXDC 45	☆	2.01	10.8	70	8	20.5	98	86	30	13	114	—	59	17.5	M10×20
LRXD 45	☆	3.13									154	60	99		
LRXDG 45	☆	4.29									194	80	139		
LRXDC 55	☆	3.17	14.1	80	9	23.5	112	100	37.5	12.5	136	—	72	20	M12×25
LRXD 55	☆	4.97									184	75	120		
LRXDG 55	☆	7.06									238	95	174		
LRXDC 65	☆	5.52	22.6	90	12	31.5	136	126	38	25	181	—	95	26.6	M16×25
LRXD 65	☆	8.70									245	70	159		
LRXDG 65	☆	12.1									309	120	223		

H <sub>3</sub>	Dimensions of track rail mm							Mounting bolt for track rail mm Bolt size × length	Basic dynamic load rating <sup>(2)</sup> C N	Basic static load rating <sup>(2)</sup> C <sub>0</sub> N	Static moment rating <sup>(2)</sup>		
	W	H <sub>4</sub>	d <sub>3</sub>	d <sub>4</sub>	h	E	F				T <sub>0</sub> N·m	T <sub>X</sub> N·m	T <sub>Y</sub> N·m
	20	34	32	9	14	12	40				80	M 8×35	39 500
26	45	38	14	20	17	52.5	105	M12×40	58 700	100 000	2 170	1 360 8 470	1 360 8 470
									74 200	135 000	2 930	2 440 13 800	2 440 13 800
26	53	43	16	23	20	60	120	M14×45	64 100	95 600	2 660	1 010 7 800	1 010 7 800
									95 400	159 000	4 430	2 700 16 800	2 700 16 800
18	63	56	18	26	22	75	150	M16×60	124 000	223 000	6 200	5 220 29 000	5 220 29 000
									99 700	149 000	4 830	1 880 14 400	1 880 14 400
									148 000	248 000	8 040	5 040 31 100	5 040 31 100
18	63	56	18	26	22	75	150	M16×60	174 000	249 000	9 790	4 200 32 200	4 200 32 200
									260 000	415 000	16 300	11 300 69 300	11 300 69 300
									337 000	581 000	22 800	21 800 120 000	21 800 120 000

Note<sup>(1)</sup>: Track rail lengths are shown in Table 10.1 on page C-14.

<sup>(2)</sup>: The directions of basic dynamic load rating (C), basic static load rating (C<sub>0</sub>) and static moment rating (T<sub>0</sub>, T<sub>X</sub>, T<sub>Y</sub>) are shown in the sketches below. The upper values in the T<sub>X</sub> and T<sub>Y</sub> columns apply to one slide unit, and the lower values apply to two slide units in close contact.

Remark 1: The mark ☆ indicates that interchangeable specification products are available.

- 2: The appended track rail mounting bolts are hexagon socket head bolts of JIS B 1176 or equivalent.
- 3: For grease nipple specifications, see page 99.
- 4: Three grease nipple mounting thread holes are provided on the left and right end plates respectively.

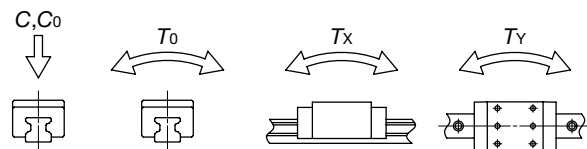

Example of identification number of assembled set (For details, see "Identification number and specification".)

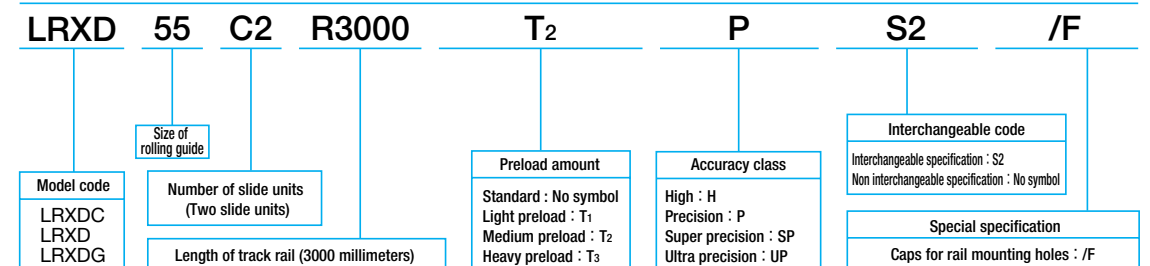

Compact block type mounted from top  
LRXSC, LRXS, LRXSG

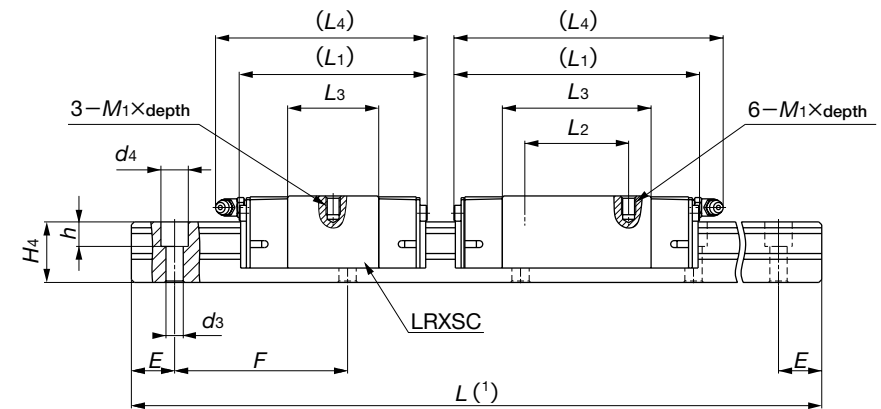
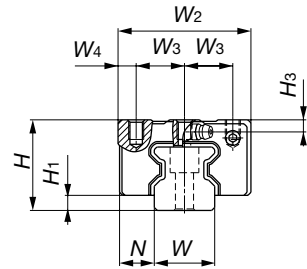

Model number	Interchangeable	Mass (Ref.)		Dimensions of assembly mm			Dimensions of slide unit mm							
		Slide unit kg	Track rail kg/m	H	H <sub>1</sub>	N	W <sub>2</sub>	W <sub>3</sub>	W <sub>4</sub>	L <sub>1</sub>	L <sub>2</sub>	L <sub>3</sub>	L <sub>4</sub>	M <sub>1</sub> ×depth <sup>(2)</sup>
LRXSC 15	☆	0.099	1.65	24	4	9.5	34	13	4	52	—	24	55	M4× 5.5
LRXS 15	☆	0.15								68	26	40	71	
LRXSG 15	☆	0.21								84	56	87		
LRXSC 20	☆	0.21	2.73	30	5	12	44	16	6	66	—	31.6	74	M5× 6.5
LRXS 20	☆	0.31								86	36	51.6	94	
LRXSG 20	☆	0.42								106	50	71.6	114	
LRXSC 25	☆	0.30	3.59	36	6	12.5	48	17.5	6.5	74	—	36	83	M6× 9
LRXS 25	☆	0.47								98	35	60	107	
LRXSG 25	☆	0.57								113	50	75	122	
LRXSC 30	☆	0.54	5.01	42	6.5	16	60	20	10	85	—	42.4	95	M8×11
LRXS 30	☆	0.83								113	40	70.4	123	
LRXSG 30	☆	1.05								134	60	91.4	144	

H <sub>3</sub>	Dimension of track rail mm								Mounting bolt for track rail mm Bolt size × length	Basic dynamic load rating <sup>(3)</sup> C N	Basic static load rating <sup>(3)</sup> C <sub>0</sub> N	Static rated moment <sup>(3)</sup>		
	W	H <sub>4</sub>	d <sub>3</sub>	d <sub>4</sub>	h	E	F	T <sub>0</sub> N·m				T <sub>X</sub> N·m	T <sub>Y</sub> N·m	
3.5	15	16.5	4.5	8	6	30	60	M4×16	7 730	12 000	113	50.6	50.6	
												136	136	
												457	457	
4	20	21	6	9.5	8.5	30	60	M5×20	14 900	28 000	263	262	262	
												1 590	1 590	
												150	150	
5	23	24.5	7	11	9	30	60	M6×25	21 600	33 800	500	1 260	1 260	
												379	379	
												2 520	2 520	
6.5	28	28	9	14	12	40	80	M8×28	30 100	58 900	760	713	713	
												4 200	4 200	
												213	213	
6.5	28	28	9	14	12	40	80	M8×28	29 200	44 600	808	213	213	
												1 810	1 810	
												573	573	
6.5	28	28	9	14	12	40	80	M8×28	32 100	56 300	833	3 800	3 800	
												885	885	
												5 380	5 380	
6.5	28	28	9	14	12	40	80	M8×28	38 200	70 300	1 040	329	329	
												2 740	2 740	
												883	883	
6.5	28	28	9	14	12	40	80	M8×28	43 400	74 400	1 350	5 780	5 780	
												1 470	1 470	
												8 740	8 740	

Note<sup>(1)</sup>: Track rail lengths are shown in Table 10.1 on page C-14.  
<sup>(2)</sup>: Recommended insertion depth for mounting slide unit are shown in Table 9 on page C-13.  
<sup>(3)</sup>: The directions of basic dynamic load rating (C), basic static load rating (C<sub>0</sub>) and static moment rating (T<sub>0</sub>, T<sub>X</sub>, T<sub>Y</sub>) are shown in the sketches below. The upper values in the T<sub>X</sub> and T<sub>Y</sub> columns apply to one slide unit, and the lower values apply to two slide units in close contact.  
**Remark 1**: The mark ☆ indicates that interchangeable specification products are available.  
**2**: The appended track rail mounting bolts are hexagon socket head bolts of JIS1176 or equivalent.  
**3**: For grease nipple specification, see page 99.  
**4**: A grease nipple mounting thread holes are provided on the left and right end plates respectively.

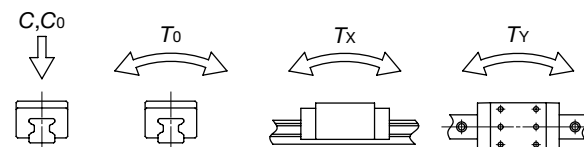

Example of identification number of assembled set (For details, see "Identification number and specification".)

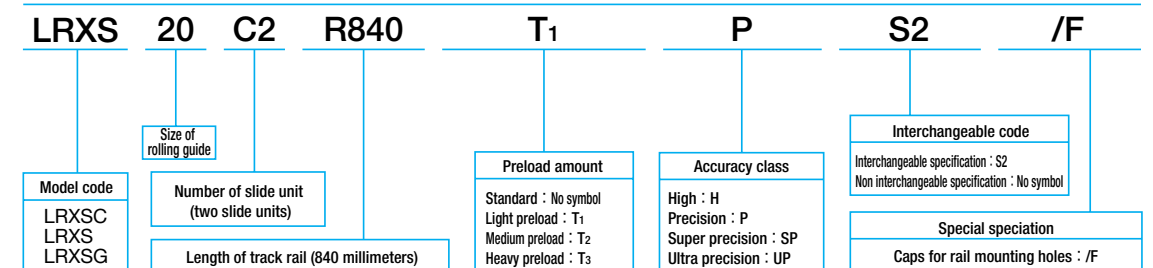

# Linear Ball Spline



LINEAR BALL SPLINE

Description of Linear Ball Spline.....	D-2
Linear Ball Spline G.....	D-28
Block type Linear Ball Spline.....	D-46
Stroke Ball Spline LS.....	D-54

## Features of Linear Ball Spline

**IKO** Linear Ball Spline is a linear motion rolling guide which achieves endless linear motion of an external cylinder along a spline shaft. As steel balls make rolling contact with the spline grooves, radial loads as well as rotating torque can be received. This product is most suitable for mechanisms that perform linear motion while transmitting rotating torque. The spline grooves have almost the same radius of curvature as that of steel balls, and can receive a large load. This product has a large load capacity and will be useful for achieving compact design of machines and equipment.

### 1 Interchangeable

The dimensions of spline shafts and external cylinders (or slide units) of the interchangeable specification are individually controlled, so that the spline shafts and external cylinders (or slide units) can be combined, added or exchanged freely. (Linear Ball Spline G series and Block type Linear Ball Spline series)

### 2 Wide variations

Size variations range from a very small size with shaft diameter of 2 mm to larger sizes up to 50 mm. Three types of external cylinders (including one slide unit type) are also available: standard type, flange type and block type. These products can be selected to meet the requirements for each application.

### 3 Compact design with high rigidity

Large diameter steel balls are arranged in two rows and in four point contact with the raceways, achieving compact design with high rigidity. (Linear Ball Spline G series and Block type Linear Ball Spline series)

### 4 High positioning accuracy

By applying a suitable preload, clearance in the rotational direction is eliminated. So high positioning accuracy in the rotational direction can be obtained.

### 5 Smooth motion with low friction

The steel ball re-circulation was thoroughly analyzed, resulting in an optimal design of re-circulation route through end caps. High speed operation as well as smooth motion with low friction can be achieved.

## Series of Linear Ball Spline

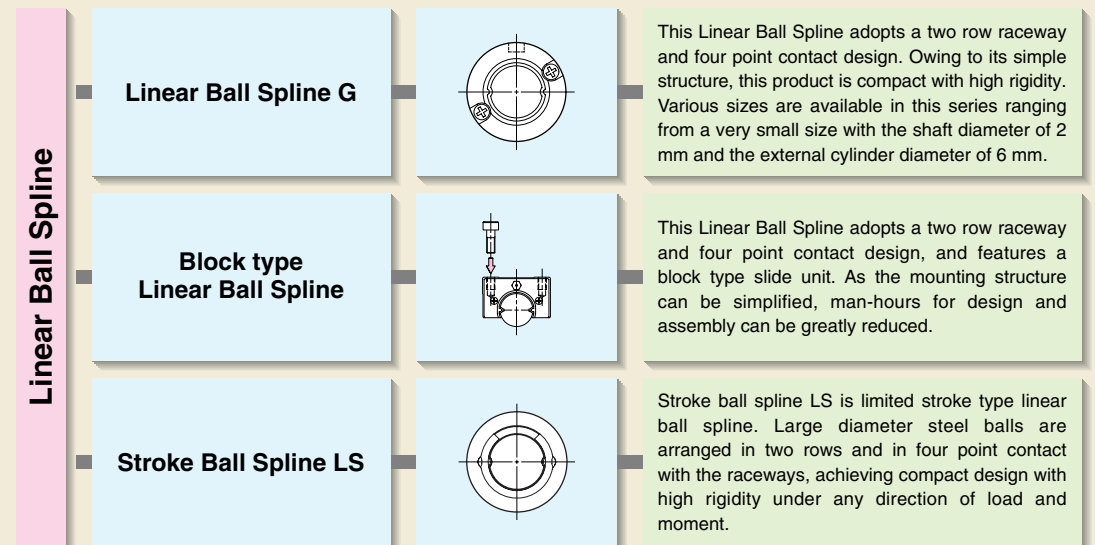

### Series and size variation

Size	Linear Ball Spline G	Block type Linear Ball Spline	Stroke Ball Spline LS
2	○	—	—
3	○	—	—
4	○	—	○
5	○	—	○
6	○	○	○
8	○	○	—
10	○	○	—
12	○	—	—
13	—	○	—
15	○	—	—
16	—	○	—
20	○	○	—
25	○	○	—
30	○	—	—
40	○	—	—
50	—	—	—

Remark : For the details of applicable specifications and sizes, see the description of each series.



## Interchangeable Specification

**IKO** Linear Ball Spline include interchangeable specification products. The spline shafts and the external cylinders (or the slide units) of this specification can be handled separately and can be assembled to make a set as required.

The interchangeable specification guides are produced with the original precision manufacturing technology, making the most of the **IKO** guide designs: namely, the simple two-row raceway and four-point contact ball design. The dimensional accuracy of both external cylinders (or slide units) and spline shafts is strictly controlled to achieve the interchangeability of higher standard.

**Interchangeable**

A new product selection system is offered, in which external cylinders (or slide units) and spline shafts can be selected separately, as and when required !!

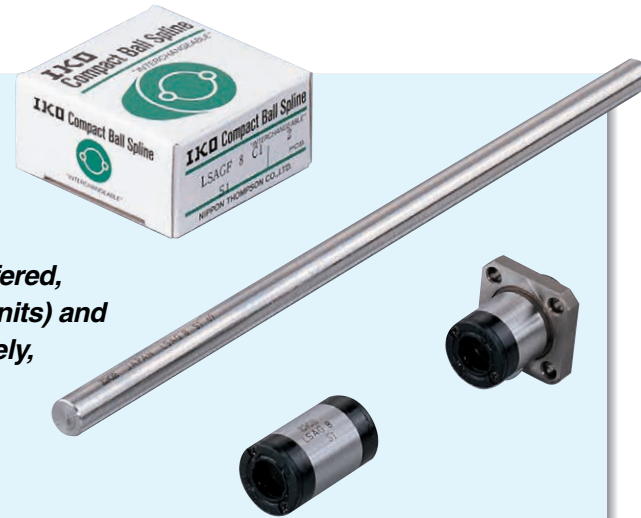

### Wide range of variations

The models of Linear Ball Spline G for which the interchangeable specification is applicable are indicated by an asterisk (☆) in the table of dimensions of each series.

All models of Block type Linear Ball Spline are interchangeable specification products.

#### Linear Ball Spline G

(page D-28 to page D-45)

**8 types and 56 models**

#### Block type Linear Ball Spline

(page D-46 to page D-53)

**3 types and 17 models**

### Features of interchangeable specification products [1]

#### Interchangeable external cylinder, Interchangeable slide unit

Various types of external cylinders with different shapes and lengths and solid shafts and hollow shafts are prepared. All of these external cylinders and spline shafts can be freely combined.

#### Linear Ball Spline G

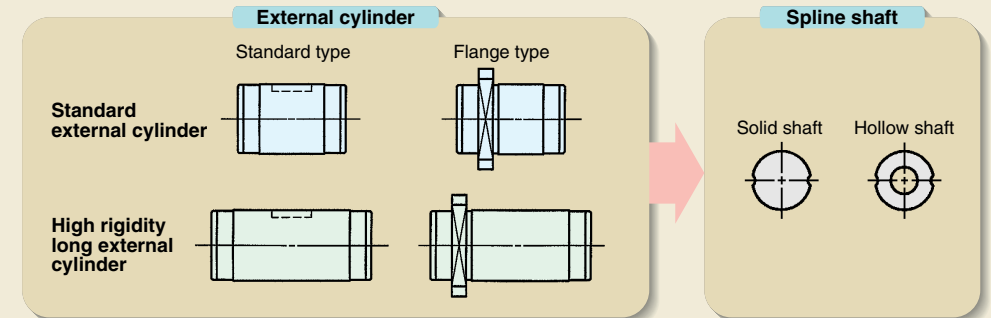

#### Block type Linear Ball Spline

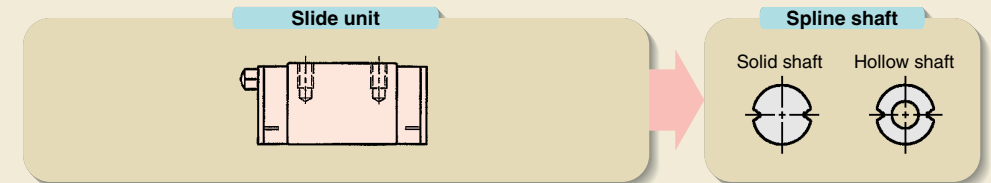

### Features of interchangeable specification products [2]

#### Interchangeable with high accuracy

Two accuracy classes, Ordinary and High are prepared for the interchangeable specification products so that these products can be used for applications requiring high running accuracy.

### Features of interchangeable specification products [3]

#### Interchangeable with preload

High accuracy dimensional control owing to a simple structure has made it possible to realize the interchangeability among preloaded external cylinders (or slide units).

In the interchangeable specification products, light preload type is prepared so that these products can be used for applications requiring one step higher rigidity.

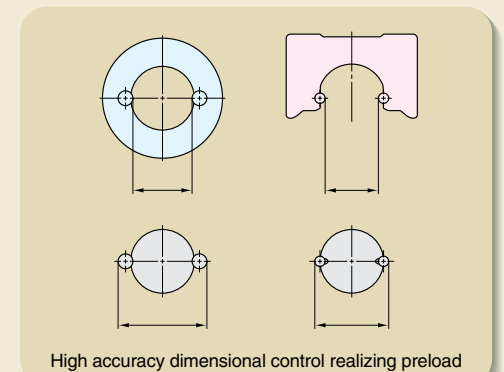

## Identification Number

The identification number of **IKO** Linear Ball Spline consists of a model code, a size, a part code, a material symbol, a preload symbol, a classification symbol, an interchangeable code and any supplemental codes. Examples of identification number are shown below. For details of specifications, see the description of each series.

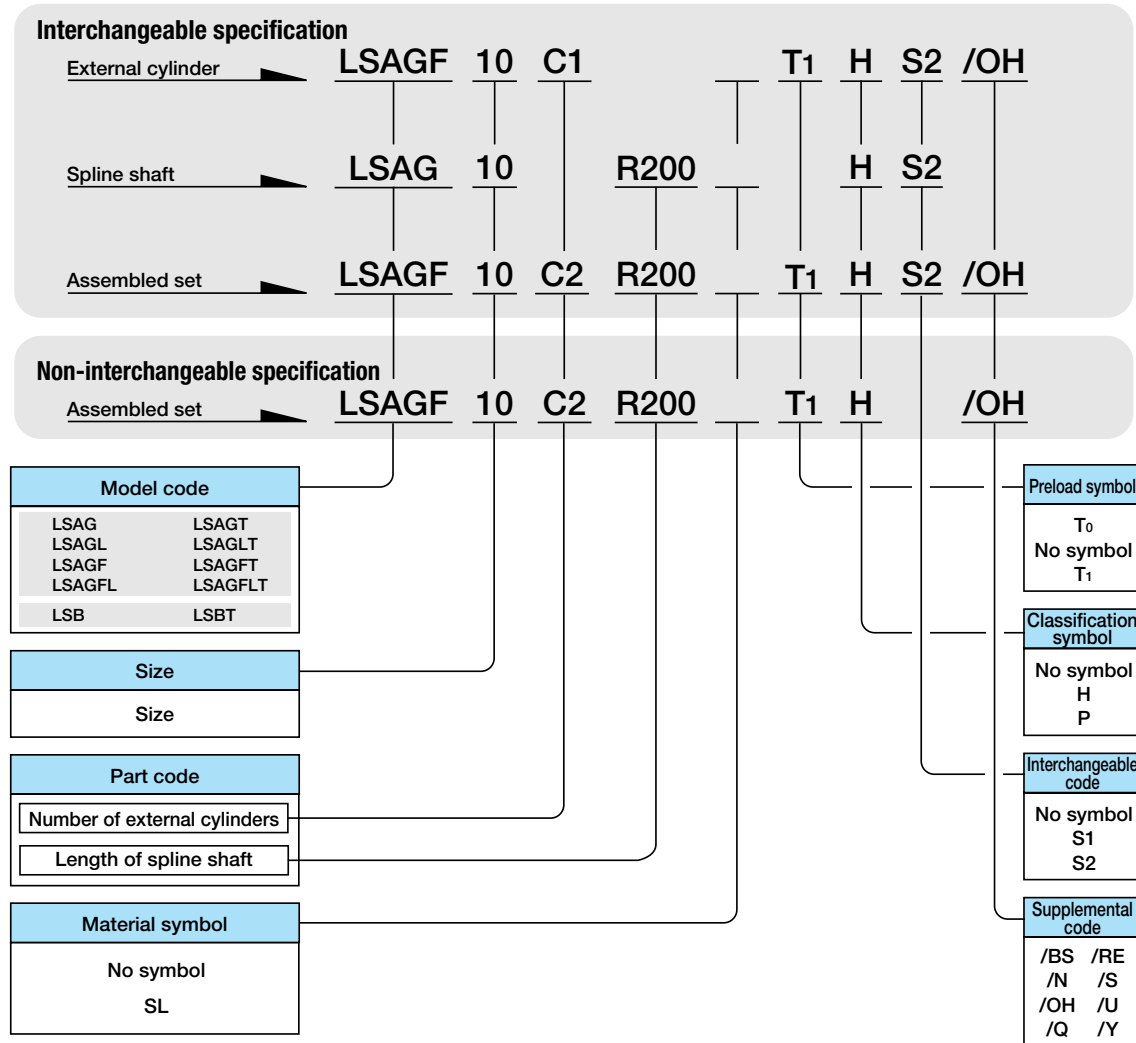

## For Ordering

When ordering assembled sets of Linear Ball Spline, indicate the number of sets which is always represented by the number of spline shafts. For ordering the external cylinders and spline shafts of interchangeable specification separately, indicate the number of external cylinders and the number of spline shafts, respectively. Examples of ordering are shown below.

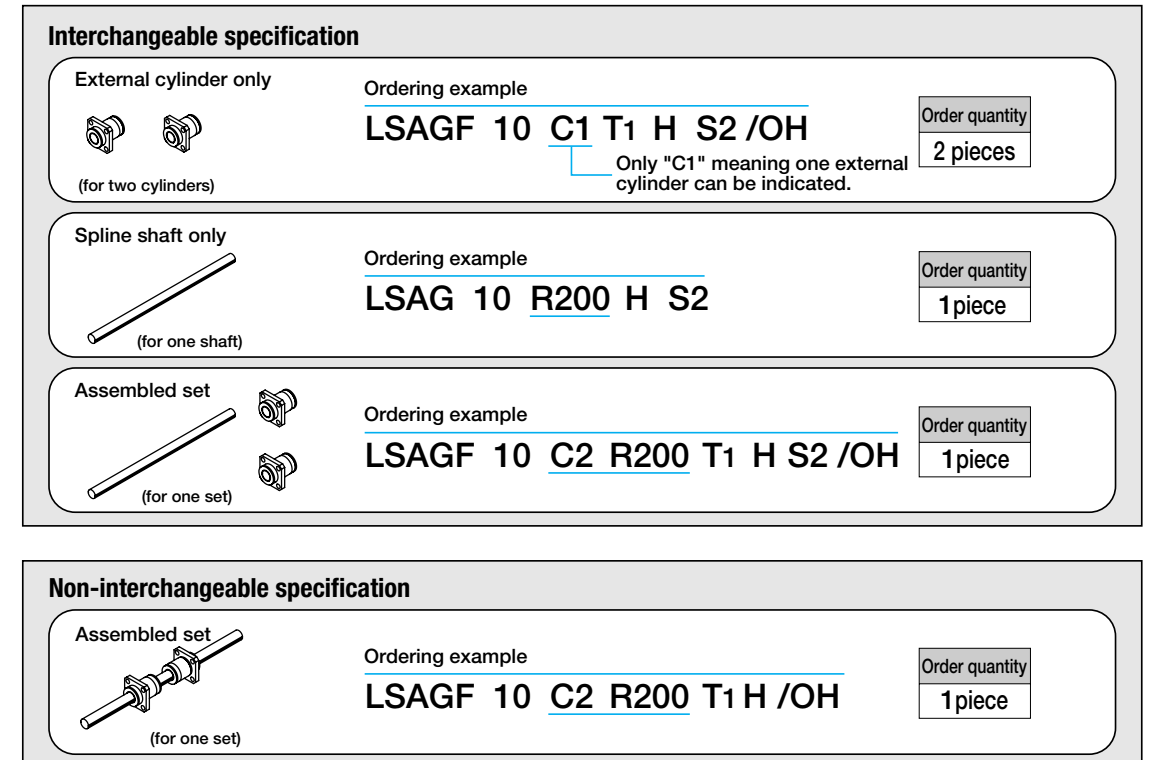

## Load Rating

The load ratings of **IKO** Linear Ball Spline are defined for downward load. Summarized descriptions of load ratings are given below. For details of load rating definitions and load calculation, see "General description".

### Basic dynamic load rating $C$

The basic dynamic load rating is defined as the constant load both in direction and magnitude under which a group of identical Linear Ball Splines are individually operated and 90% of the units in the group can travel  $50 \times 10^3$  meters free from material damage due to rolling contact fatigue.

### Basic static load rating $C_0$

The basic static load rating is defined as the static load that gives a prescribed constant contact stress at the center of the contact area between the rolling element and raceway receiving the maximum load.

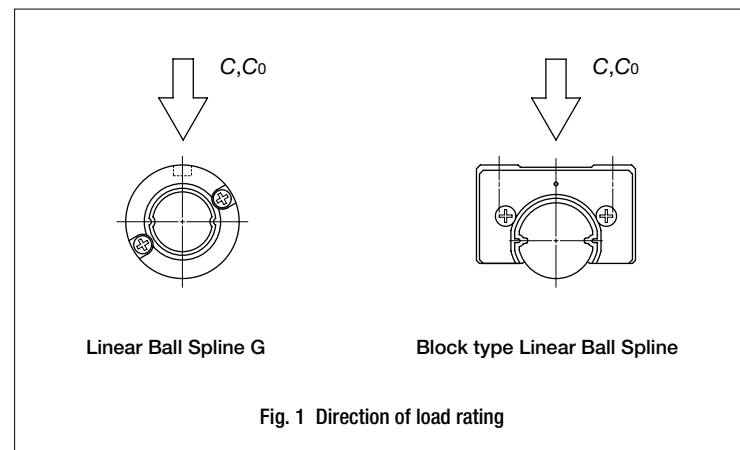

### Dynamic torque rating $T$

The dynamic torque rating is defined as the constant torque both in direction and magnitude under which a group of identical Linear Ball Splines are individually operated and 90% of the units in the group can travel  $50 \times 10^3$  meters free from material damage due to rolling contact fatigue.

### Static torque rating $T_0$ and static moment rating $T_x, T_y$

The static torque rating or the static moment rating is defined as the static torque or moment load that gives a prescribed constant contact stress at the center of the contact area between the rolling element and raceway receiving the maximum load when a torque or a moment is loaded.

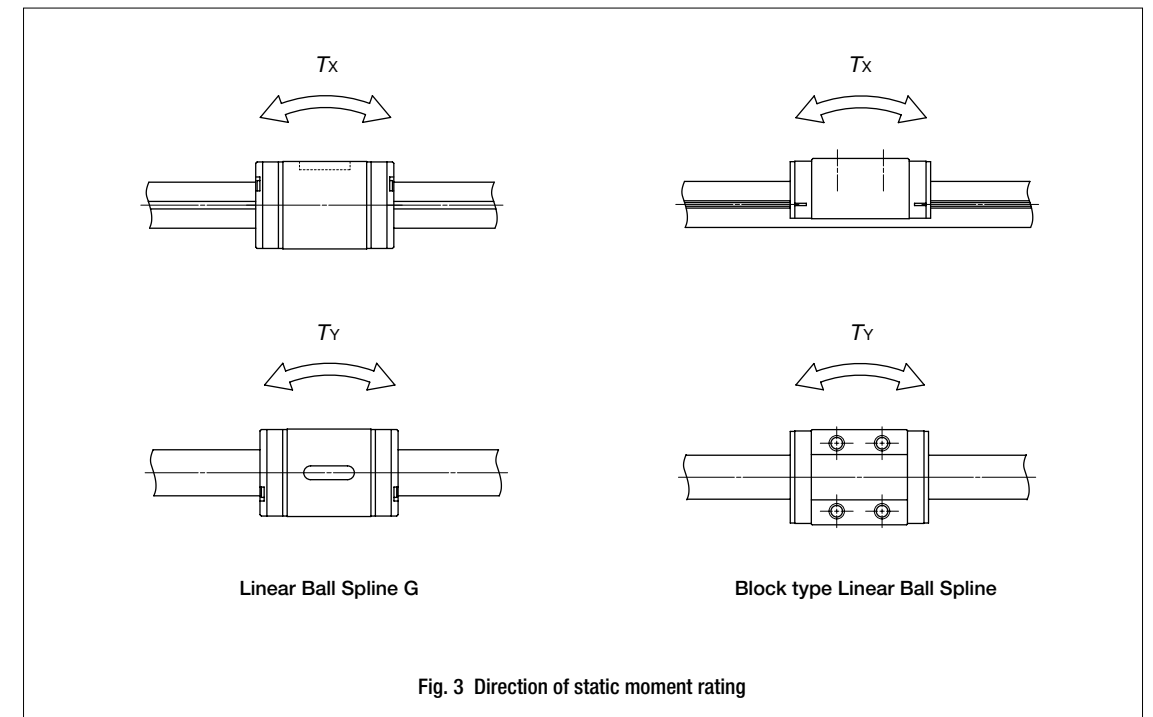
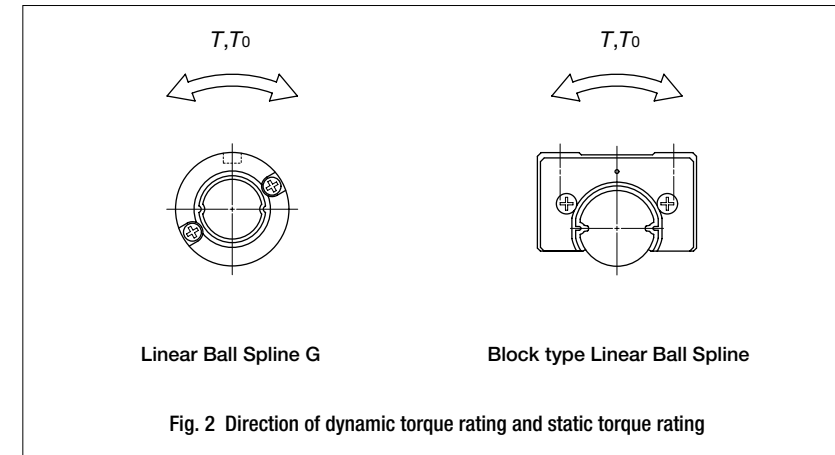

## ● Load direction and load rating

Since the load ratings of **IKO** Linear Ball Spline given in the table of dimensions are for downward load, they must be corrected for the load direction for upward or lateral load. The corrected basic dynamic load ratings and basic static load ratings are shown in Table 1.

Table 1 Load ratings corrected for the load direction

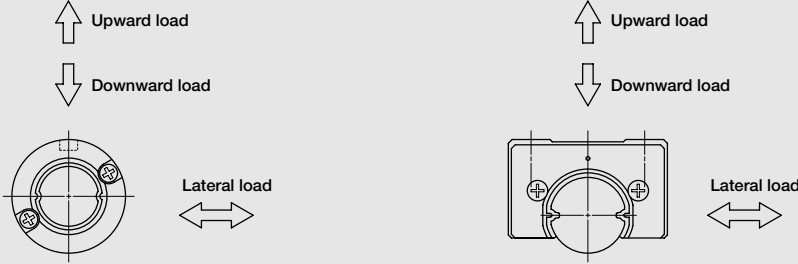

Load rating and load direction	Series and size	Dynamic load rating			Static load rating		
		Load direction			Load direction		
		Downward	Upward	Lateral	Downward	Upward	Lateral
Linear Ball Spline G	2~12	$C$	$C$	$1.47C$	$C_0$	$C_0$	$1.73C_0$
	15~50	$C$	$C$	$1.13C$	$C_0$	$C_0$	$1.19C_0$
Block type Linear Ball Spline	6~20	$C$	$C$	$0.88C$	$C_0$	$C_0$	$0.84C_0$
	25	$C$	$C$	$C$	$C_0$	$C_0$	$C_0$
Stroke Ball Spline LS	4~ 6	$C$	$C$	$1.47C$	$C_0$	$C_0$	$1.73C_0$

## Accuracy

Three classes of accuracy, Ordinary, High, and Precision are specified for **IKO** Linear Ball Spline. Table 2 summarizes applicable classes for each series, and Tables 3 to 5 show accuracy of each series. For details of applicable classes, see the description of each series. For the accuracy of series other than those shown in Table 2, consult **IKO** for further information.

Table 2 Accuracy class

Classification (Symbol)	Ordinary (No symbol)	High (H)	Precision (P)
Series			
Linear Ball Spline G	☆	☆	○
Block type Linear Ball Spline	☆	☆	—

Remark : The mark ☆ indicates that it is also applicable to interchangeable specification products.

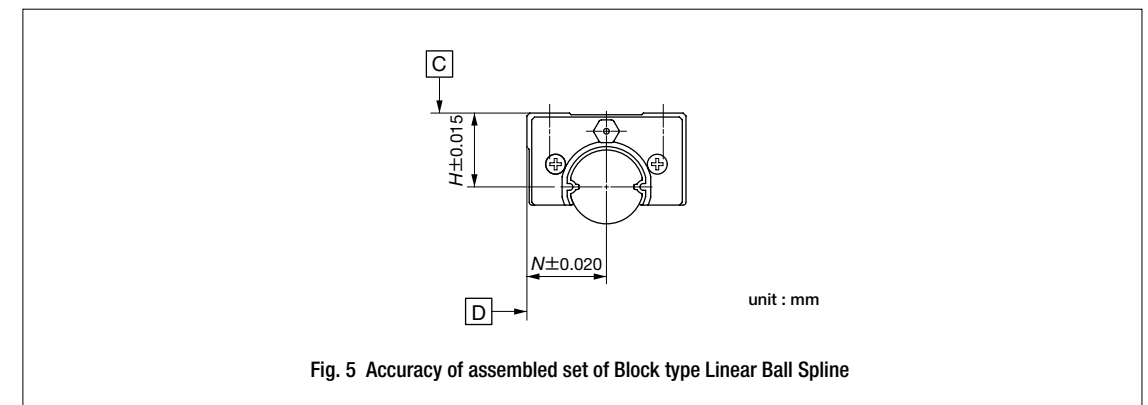
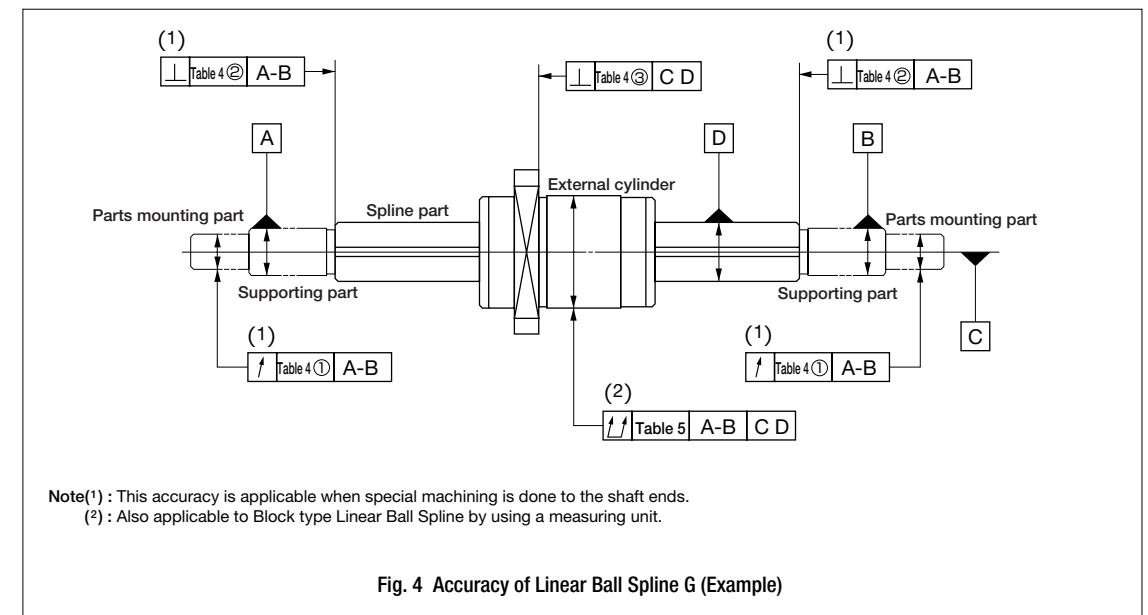

Table 3 Twist of grooves with respect to effective length of the spline part unit :  $\mu\text{m}$

Accuracy class	Ordinary (No symbol)	High (H)	Precision (P)
Allowable value	33	13	6

Remark : The values are applicable to any length of 100 mm over the effective length of the spline part.

Table 4 Accuracy of each part of Linear Ball Spline G unit :  $\mu\text{m}$

Model number	Relative to axial line of supporting part of spline shaft						③ Perpendicularity of mounting surface of flange relative to axial line of spline shaft		
	① Radial runout of periphery of parts mounting part			② Perpendicularity of spline part end face			Ordinary (No symbol)	High (H)	Precision (P)
	Ordinary (No symbol)	High (H)	Precision (P)	Ordinary (No symbol)	High (H)	Precision (P)			
LSAG 2	33	14	8	22	9	6	27	11	8
LSAG 3	33	14	8	22	9	6	27	11	8
LSAG 4	33	14	8	22	9	6	27	11	8
LS 4	—	—	8	—	—	6	—	—	—
LSAG 5	33	14	8	22	9	6	27	11	8
LS 5	—	—	8	—	—	6	—	—	—
LSAG 6	33	14	8	22	9	6	27	11	8
LS 6	—	—	8	—	—	6	—	—	—
LSAG 8	33	14	8	22	9	6	27	11	8
LSAG 10	41	17	10	22	9	6	33	13	9
LSAG 12	41	17	10	22	9	6	33	13	9
LSAG 15	46	19	12	27	11	8	33	13	9
LSAG 20	46	19	12	27	11	8	33	13	9
LSAG 25	53	22	13	33	13	9	39	16	11
LSAG 30	53	22	13	33	13	9	39	16	11
LSAG 40	62	25	15	39	16	11	46	19	13
LSAG 50	62	25	15	39	16	11	—	—	—

Remark : The above table shows representative model numbers, but is applicable to all models. However, the accuracy of ① and ② is applicable when special machining is done to the shaft ends. The accuracy of ③ is applicable to LSAGF(T) and LSAGFL(T).

Table 5 Total radial runout of axial line of spline shaft unit :  $\mu\text{m}$

Overall length of spline shaft mm		LSAG 2 LSAG 3 LSAG 4 LSAG 5 LSAG 6 LSAG 8			LSB 6 LSB 8			LSAG 10 LSAG 12			LSB 10 LSB 13			LSAG 15 LSAG 20			LSB 16 LSB 20		
		Ordinary (No symbol)	High (H)	Precision (P)	Ordinary (No symbol)	High (H)	Precision (P)	Ordinary (No symbol)	High (H)	Precision (P)	Ordinary (No symbol)	High (H)	Precision (P)	Ordinary (No symbol)	High (H)	Precision (P)			
—	200	72	46	26	59	36	20	56	34	18									
200	315	133	89	57	83	54	32	71	45	25									
315	400	185	126	82	103	68	41	83	53	31									
400	500	236	163	108	123	82	51	95	62	38									
500	630	—	—	—	151	102	65	112	75	46									
630	800	—	—	—	190	130	85	137	92	58									
800	1 000	—	—	—	—	—	—	170	115	75									

Overall length of spline shaft mm		LSAG 25 LSAG 30			LSB 25			LSAG 40 LSAG 50		
		Ordinary (No symbol)	High (H)	Precision (P)	Ordinary (No symbol)	High (H)	Precision (P)	Ordinary (No symbol)	High (H)	Precision (P)
—	200	53	32	18	53	32	16			
200	315	58	39	21	58	36	19			
315	400	70	44	25	63	39	21			
400	500	78	50	29	68	43	24			
500	630	88	57	34	74	47	27			
630	800	103	68	42	84	54	32			
800	1 000	124	83	52	97	63	38			
1 000	1 250	151	102	65	114	76	47			

Remark : The above table shows representative model numbers, but is applicable to all models.

Overall length of spline shaft mm		LS 4 LS 5 LS 6		
		Ordinary (No symbol)	High (H)	Precision (P)
—	200	—	—	26
200	300	—	—	57

Table 6 Measuring methods of accuracy

Item	Measuring methods	Illustrations of measuring method
Twist of grooves with respect to effective length of the spline shaft (See Table 3.)	Fix and support the spline shaft. Then apply a torsional moment on the external cylinder (or the measuring unit) in a suitable direction before placing a dial gage probe in a perpendicular direction to the spline shaft and against the side face of the sunk key attached on the external cylinder. Measure the runout when the external cylinder and the gage have traveled together 100 millimeters on any effective part of the spline shaft. However, the gage should be applied as near as possible to the outer periphery of the external cylinder.	
(1) Radial runout of periphery of parts mounting part relative to axial line of supporting part of spline shaft (See Table 4 ①.)	While supporting the spline shaft at its supporting parts, place dial gage probes to the outer peripheral faces of the parts mounting parts, and measure the runout from one rotation of the spline shaft.	
(1) Perpendicularity of spline end face relative to axial line of supporting part of spline shaft (See Table 4 ②.)	While supporting the spline shaft at its supporting parts and at one spline shaft end, place a dial gage probe to the spline end face and measure the runout from one rotation of the spline shaft.	
Perpendicularity of mounting surface of flange relative to axial line of spline shaft (See Table 4 ③.)	While supporting the spline shaft at both center holes and at the outer peripheral face of the spline shaft adjacent to the external cylinder, and while fixing the external cylinder to the spline shaft, place a dial gage probe to the mounting surface of the flange of the external cylinder and measure the perpendicularity from runout caused by one rotation of the spline shaft.	

Total radial runout of axial line of spline shaft (See Table 5.)	While supporting the spline shaft at its supporting parts or at both center holes, place a dial gage probe to the external peripheral face of the external cylinder (or measuring unit), and measure the runout at several positions in the axial direction while turning the spline shaft one rotation. Use the maximum value.	
--	---	--

Note(1) : This accuracy is applicable when special machining is done to the shaft ends.

## Preload

The average amount of preload for **IKO** Linear Ball Spline is shown in Table 7. A summary of applicable preload types is shown in Table 8. For details, see the description of each series.

Table 7 Preload amount

Preload type	Item	Symbol	Preload amount N	Application
Clearance		T <sub>0</sub>	0 (1)	• Very smooth motion
Standard		(No symbol)	0 (2)	• Smooth and precise motion
Light preload		T <sub>1</sub>	0.02C <sub>0</sub>	• Minimum vibration • Load is evenly balanced. • Smooth and precise motion

Note(1) : Zero or minimal amount of clearance  
 (2) : Zero or minimal amount of preload  
 Remark : C<sub>0</sub> means the basic static load rating.

Table 8 Applicable preload types

Series	Preload (Symbol)	Clearance (T <sub>0</sub> )	Standard (No symbol)	Light preload (T <sub>1</sub> )
Linear Ball Spline G		○	☆	☆
Block type Linear Ball Spline		—	☆	☆
Stroke Ball Spline LS		—	—	○

Remark : The mark ☆ indicates that it is also applicable to interchangeable specification products.

## Special Specifications

**IKO** Linear Ball Splines of the special specifications shown in Table 9 are available. In some cases, special specifications may not be applicable. For details, see the description of each series. When a special specification is required, add the applicable supplemental code to the end of the identification number. When a combination of several special specifications is required, arrange their supplemental codes in alphabetical order.

Table 9 Special specifications for Linear Ball Spline

Special specification	Supplemental code	Linear Ball Spline G	Block type Linear Ball Spline
Stainless steel end caps	BS	○	—
No end seal	N	☆	☆
With an oil hole	OH	☆	—
Capillary plates	Q	☆	—
Seals for special environment	RE	○	—
Spline shaft in stainless steel	S	○	—
With under seals	U	—	☆
Specified grease	Y	○	—

Remark 1 : The mark ☆ indicates that it is also applicable to interchangeable specification products.  
2 : For details of special specifications applicable to each series and their combinations, see the description of each series.

### With stainless steel end caps /BS

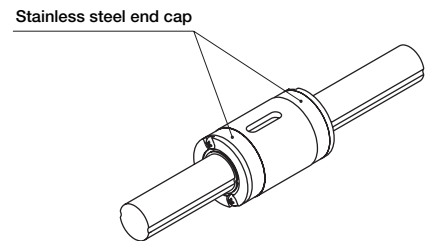

The standard synthetic resin end caps are replaced with stainless steel end caps, keeping the total length of external cylinder unchanged.

### No end seal /N

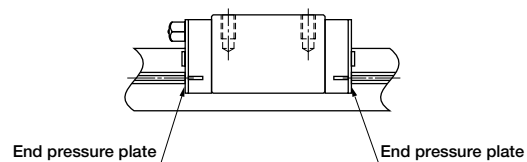

End seals at both ends of external cylinder or slide unit are replaced by end pressure plates (not in contact with the spline shaft) to reduce frictional resistance. This specification is not effective for dust protection.

### With an oil hole /OH



An oil hole is provided on the external cylinder of Linear Ball Spline G. For dimensions, see the description of each series.

### Capillary plate /Q

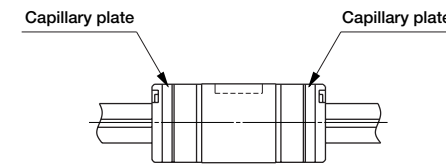

The capillary plate is assembled inside the end seal of the external cylinder. It is impregnated with lubricant so that re-lubrication interval can be made longer. For the total length of the external cylinder with capillary plate, see the description of each series.

### Spline shaft in stainless steel /S

The material of solid spline shaft of Linear Ball Spline G is changed to stainless steel. The load rating will be obtained by multiplying the load rating for the high carbon steel spline shaft by a factor of 0.8.

### With under seals /U

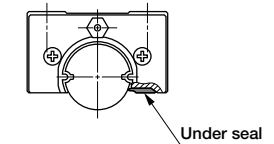

To prevent foreign substances intruding from the lower side of Block type Linear Ball Spline, seals are provided on the bottom faces of side unit.

### Seal for special environment /RE

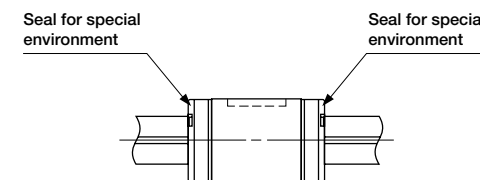

The standard end seals are changed to seals for special environment that can be used at high temperature, keeping the total length of external cylinder unchanged.

### Specified grease /YCG/YCL/YBR/YAF/YNG

The type of pre-packed grease can be changed by a supplemental code.

- ① /YCG  
**IKO** Low Dust Generation Grease for Clean Environment CG2 is pre-packed.
- ② /YCL  
**IKO** Low Dust Generation Grease for Clean Environment CGL is pre-packed.
- ③ /YBR  
MOLYCOTE BR2 Plus Grease (Dow Corning) is pre-packed.
- ④ /YAF  
**IKO** Anti-Fretting Corrosion Grease is Pre-packed.
- ⑤ /YNG  
No grease is pre-packed.

## Lubrication and Dust Protection

**IKO** Linear Ball Spline is most generally lubricated with grease, which provides easy lubrication control. A grease nipple for grease replenishment is provided on the slide unit of Block type Linear Ball Spline. Parts such as piping joints are also available, and can be delivered if required.

**IKO** Linear Ball Spline is provided with special rubber seals for dust protection. But, if a large amount of fine contaminants are present, or if large particles of foreign matter may fall on the spline shaft, it is recommended to provide bellows and other protective covers.

The size 2, 3, 4 models and Stroke Ball Spline LS are not provided with seals.

When requiring the size 3 and 4 models with seals, consult **IKO** for further information.

### Pre-packed grease

A high quality lithium-soap base grease shown in Table 10 is pre-packed in **IKO** Linear Ball Spline. For the interval and amount of grease replenishment, see "General description".

Table 10 Pre-packed grease

Series	Pre-packed grease
Linear Ball Spline G	ALVANIA EP GREASE 2 (SHELL)
Block type Linear Ball Spline	MULTEMP PS No.2 (KYODO YUSHI)

### Parts for lubrication

The slide unit of Block type Linear Ball Spline is provided with a grease nipple or oil hole for grease replenishment. Table 11 shows applicable parts for lubrication.

However, Linear Ball Spline G is not provided with a grease nipple or oil hole. For re-lubrication of this type, apply grease directly to the raceways of the spline shaft.

Table 11 Parts for lubrication

Series	Model code	Size	Grease nipple	
			Type	Applicable supply nozzle type
Block type Linear Ball Spline	LSB	6 8 10	Oil hole	Miniature greaser
		13 16 20	A-M3	A-5120V A-5240V B-5120V B-5240V
		25	A-M4	A-5120V A-5240V B-5120V B-5240V

Remark : The above table shows representative model codes, but is applicable to all models.  
When "Oil hole" is described in the grease nipple column, an oil hole shown in Table 12 is provided in place of a grease nipple.

### Oil hole

Some models of Block type Linear Ball Spline are provided with an oil hole as shown in Table 12. (See also Table 11.) For grease replenishment, use a syringe type dispenser. The specially prepared miniature greaser is also available. For specifications of the miniature greaser, see page 101.

Table 12 Oil hole

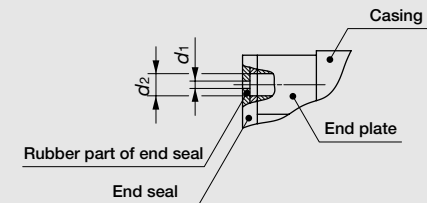

Series name	Size	Oil hole	
		$d_1$	$d_2$
Block type Linear Ball Spline	6 8	0.5	1.2
	10	0.5	1.5

unit : mm



## ● Grease nipple and supply nozzle

Table 13 shows the specifications of grease nipples and applicable types of supply nozzles. For the specifications of supply nozzles, see page 97.

Type	Grease nipple Shape and dimension	Type	Applicable supply nozzle Shape
A-M3		A-5120V A-5240V B-5120V B-5240V	Straight type 
A-M4			Straight type with angle 

## Precautions for Use

### External cylinder fit

The normal fit between the external cylinder of Linear Ball Spline G and housing hole is the transition fit (J7). The clearance fit (H7) can be used, when the requirement for accuracy and rigidity is not very strict.

### Standard mounting examples of Linear Ball Spline G

Fig. 6 shows the standard mounting examples of the external cylinder of Linear Ball Spline G. To prevent the rotation of the external cylinders of LSAG2, LSAG3 and LSAG(T)4, an M1.2 to M1.6 screw for LSAG2, an M1.6 to M2 screw for LSAG3 and an M2 to M2.5 screw for LSAG(T)4 are set to the countersink provided on each cylinder. Avoid deforming the external cylinder when tightening the screw.

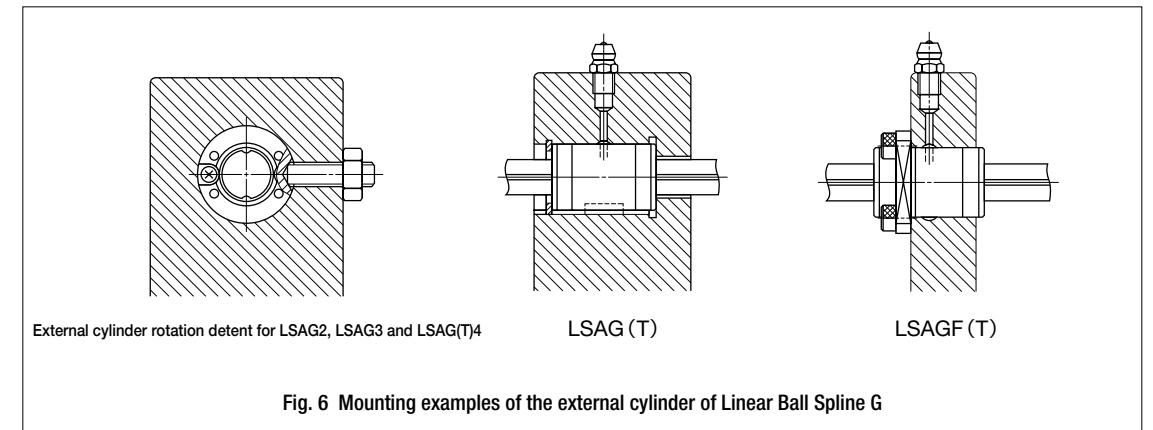

### Reference mounting surface of Block type Linear Ball Spline

To mount Block type Linear Ball Spline, correctly fit the reference mounting surface of the slide unit to the reference mounting surface of the table, and then fix them tightly. The slide unit reference mounting surface of Block type Linear Ball Spline is always the side surface opposite to the **IKO** mark. (See Fig. 7.)

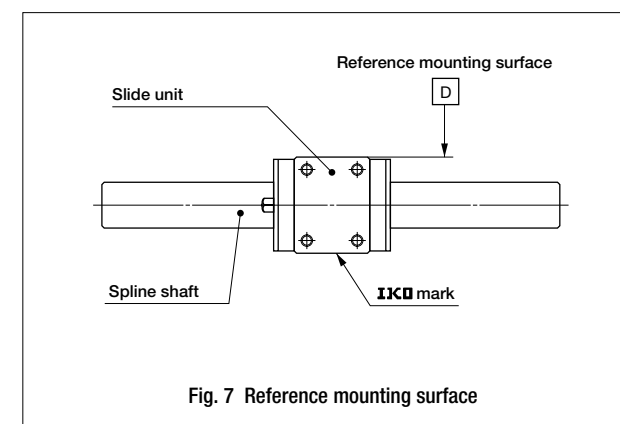

## Standard mounting example of Block type Linear Ball Spline

The outer peripheral surface of the spline shaft, and the reference mounting surface D and mounting surface C of the slide unit of Block type Linear Ball Spline are accurately finished by grinding as shown in Fig. 8. Stable and high accuracy linear motion can be obtained by finishing the mating mounting surfaces of machines or equipment with high accuracy and correctly mounting the Linear Ball Spline on these surfaces. It is recommended to make a relieved fillet at the corner of the mating reference mounting surface as shown in Table 14. Table 14 shows the recommended shoulder height of the mating reference mounting surface.

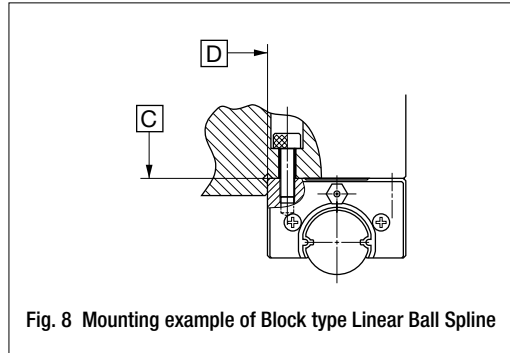
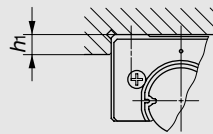

Fig. 8 Mounting example of Block type Linear Ball Spline

Table 14 Shoulder height of the mating reference mounting surface of Block type Linear Ball Spline

unit : mm

Model number	Shoulder height $h_1$
LSB 6	2
LSB 8	2.5
LSB 10	3
LSB 13	3.5
LSB 16	4
LSB 20	5
LSB 25	6



Remark : The above table shows representative model numbers, but is applicable to all models.

## Mounting example of Stroke Ball Spline LS

### ① Additional machining of spline shaft

The high carbon steel spline shaft is hardened by induction hardening. When additional machining on the shaft end is needed, make sure that the maximum diameter of the shaft end machining part does not exceed the dimension  $d_1$  shown in the dimension tables. Spline shafts with special end shapes can be prepared upon request. Consult **IKO** for further information.

### ② Operating temperature

The maximum ambient temperature 120°C. In case of continuously operation, ambient temperature should not exceed 100°C.

### ③ Caution in the operation

Stroke length should be within effective stroke length in dimension table.

Cage creeping may occur under unsteady high-speed operation and/or moment load condition. A full length of stroking is necessary to correct cage position in periodical operation interval.

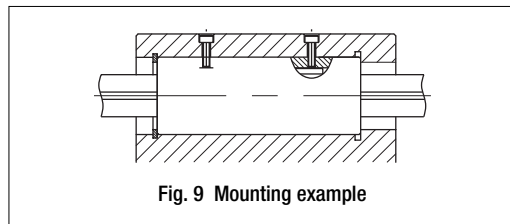

Fig. 9 Mounting example

## Additional machining of spline shaft end

The high carbon steel spline shaft is hardened by induction hardening. When additional machining on the shaft end is needed, make sure that the maximum diameter of the shaft end machining part does not exceed the dimension  $d_1$  shown in the table of dimensions. Spline shafts with special end shapes can be prepared upon request. Consult **IKO** for further information.

## Multiple external cylinders or slide units in close distance

When using multiple external cylinders or slide units in close distance to each other, actual load may be greater than the calculated load depending on the accuracy of the mounting surfaces and the reference mounting surfaces of the machine. It is suggested in such cases to assume a greater load than the calculated load.

For Linear Ball Spline G, the key grooves of the external cylinders are aligned before delivery, when two or more external cylinders are assembled on a single spline shaft and two or more keys are used to fix the external cylinders in the rotational direction.

For Block type Linear Ball Spline, dimensional variations of  $H$  and  $N$  among a set can be specified upon request. Consult **IKO** for further information.

## Arrangement of flange type external cylinders of Linear Ball Spline G (Non-interchangeable specification)

Multiple flange type external cylinders of non-interchangeable Linear Ball Spline G are arranged as shown in Table 15. Other arrangements are also available. Consult **IKO** for further information.

Table 15 Arrangement of flange type external cylinders of Linear Ball Spline G (Non-interchangeable specification)

Number of external cylinders	Arrangement of external cylinders
1	
2	
3	
4	
5	
6	

## Operating temperature

The maximum operating temperature is 120°C and a continuous operation is possible at temperatures up to 100°C. When the temperature exceeds 100°C, consult **IKO**.

In case of "With capillary plates" of special specification, operate below 80°C.

## Precautions for Mounting

### When mounting multiple sets at the same time

- Interchangeable specification product  
Assemble an external cylinder (or a slide unit) and a spline shaft with the same interchangeable code ("S2" and "S2").
- Non-interchangeable specification product  
Use an assembly of external cylinder and spline shaft as delivered without changing the combination.

### Assembling an external cylinder (or a slide unit) and a spline shaft

- Assembling Linear Ball Spline G  
When assembling the external cylinder on the spline shaft, correctly fit the grooves of the external cylinder to the grooves of the spline shaft and move the external cylinder gently in parallel direction. Rough handling will result in seal damage or dropping of steel balls.  
Non-interchangeable specification products are already assembled so as to provide the best accuracy when the external cylinder **IKO** mark and the spline shaft **IKO** mark face the same direction. (See Fig. 10.) So make sure not to change the assembly direction.

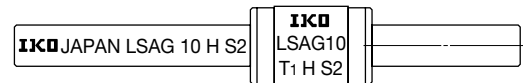

Fig. 10 Assembly direction of the external cylinder of Linear Ball Spline G

- Assembling Block type Linear Ball Spline LS  
When assembling the slide unit on the spline shaft, handle them with care to prevent steel balls from falling out.
- Assembling an external cylinder and a spline shaft  
When assembling the external cylinder on the spline shaft, correctly fit grooves of the external cylinder to the grooves of the spline shaft and move the external cylinder gently in parallel direction. Rough handling will result in dropping steel balls.  
The cage must be located in the middle position. After assemble the external cylinder to a spline shaft, push the spline shaft forward until the cage contacts to end part of external cylinder. Furthermore, push the spline shaft until a half of the maximum stroke length and return it by the same length. Then the location of the cage can be located in the middle.  
Products are assembled to provide the best accuracy when **IKO** marks of external cylinder and spline shaft face the same direction. (See Fig. 11.)



Fig. 11 Assembly direction of the external cylinder

### Mounting the external cylinder of Linear Ball Spline G and Stroke Ball Spline LS

When press-fitting the external cylinder of Linear Ball Spline G to the housing, assemble them correctly using a press and a suitable jig fixture, etc. (See Fig. 12, 13.)

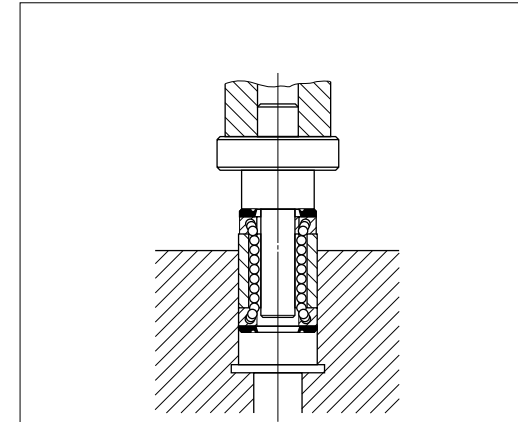

Fig. 12 Press-fitting of external cylinder of Linear Ball Spline G

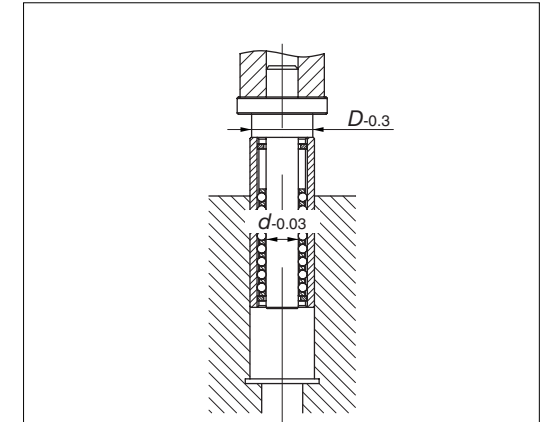

Fig. 13 Press-fitting of the external cylinder

### Tightening torque of fixing bolts

The standard torque values for Block type Linear Ball Spline fixing bolts are shown in Table 16. When machines or equipment are subjected to severe vibration, shock, large fluctuating load, or moment load, the bolts should be tightened with a torque 1.2 to 1.5 times larger than the standard torque values shown. When the mating member material is cast iron or aluminum, tightening torque should be reduced in accordance with the strength characteristics of the material.

Table 16 Tightening torque

Bolt size	Tightening torque N·m	
	Carbon steel bolt (strength division 12.9)	Stainless steel bolt (property division A2-70)
M2 × 0.4	0.49	0.31
M3 × 0.5	1.7	1.1
M4 × 0.7	4.0	—
M5 × 0.8	7.9	—
M6 × 1	13.3	—

# Linear Ball Splines

Description of each series and Table of dimensions



## Linear Ball Spline G

Page D-28 to D-45



## Block type Linear Ball Spline

Page D-46 to D-53

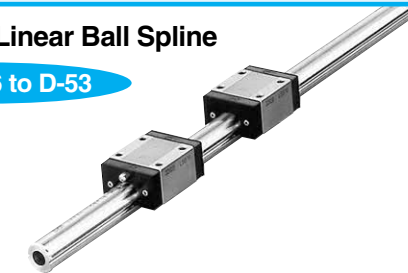

## Stroke Ball Spline LS

Page D-54 to D-59

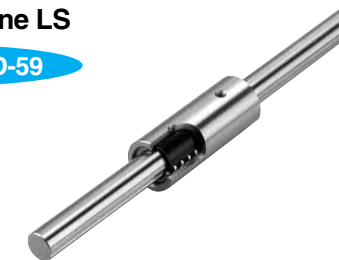

In the table of dimensions, standard products are referred to using identification numbers marked with  . The identification numbers marked with   refer to our semi-standard products.

# Linear Ball Spline G

## LSAG/LSAGF

**IICO** Linear Ball Spline G is a linear motion rolling guide which achieves endless linear motion of an external cylinder along a spline shaft. Two rows of steel balls are arranged in four point contact with the raceways. Stable high accuracy and rigidity are ensured in operations even under fluctuating loads with changing direction and magnitude or complex loads. Owing to its simple design, this product is very compact.

### Interchangeable

Linear Ball Spline G includes interchangeable specification products. The dimensions of external cylinders and spline shafts of this specification are individually controlled, so that the external cylinders and spline shafts can be combined, added or exchanged freely.

### Length of external cylinder

External cylinders of both standard type and flange type are available in two different lengths: standard and high rigidity long. They can be selected for wide applications.

### Solid shaft and hollow shaft

Two types of spline shaft, the solid shaft and the hollow shaft are available for selection suitable for each application.

### Standard type and flange type

External cylinders are available in two different shapes: the standard type (cylindrical shape) and the flange type.

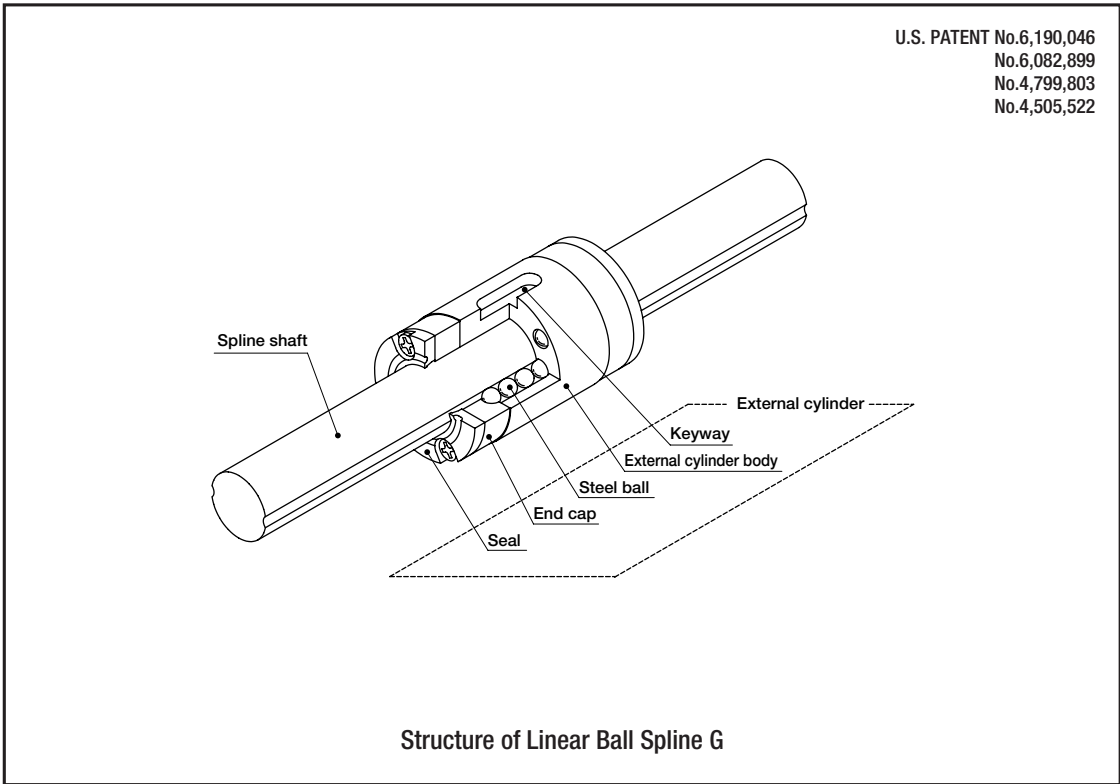

## Linear Ball Spline G series

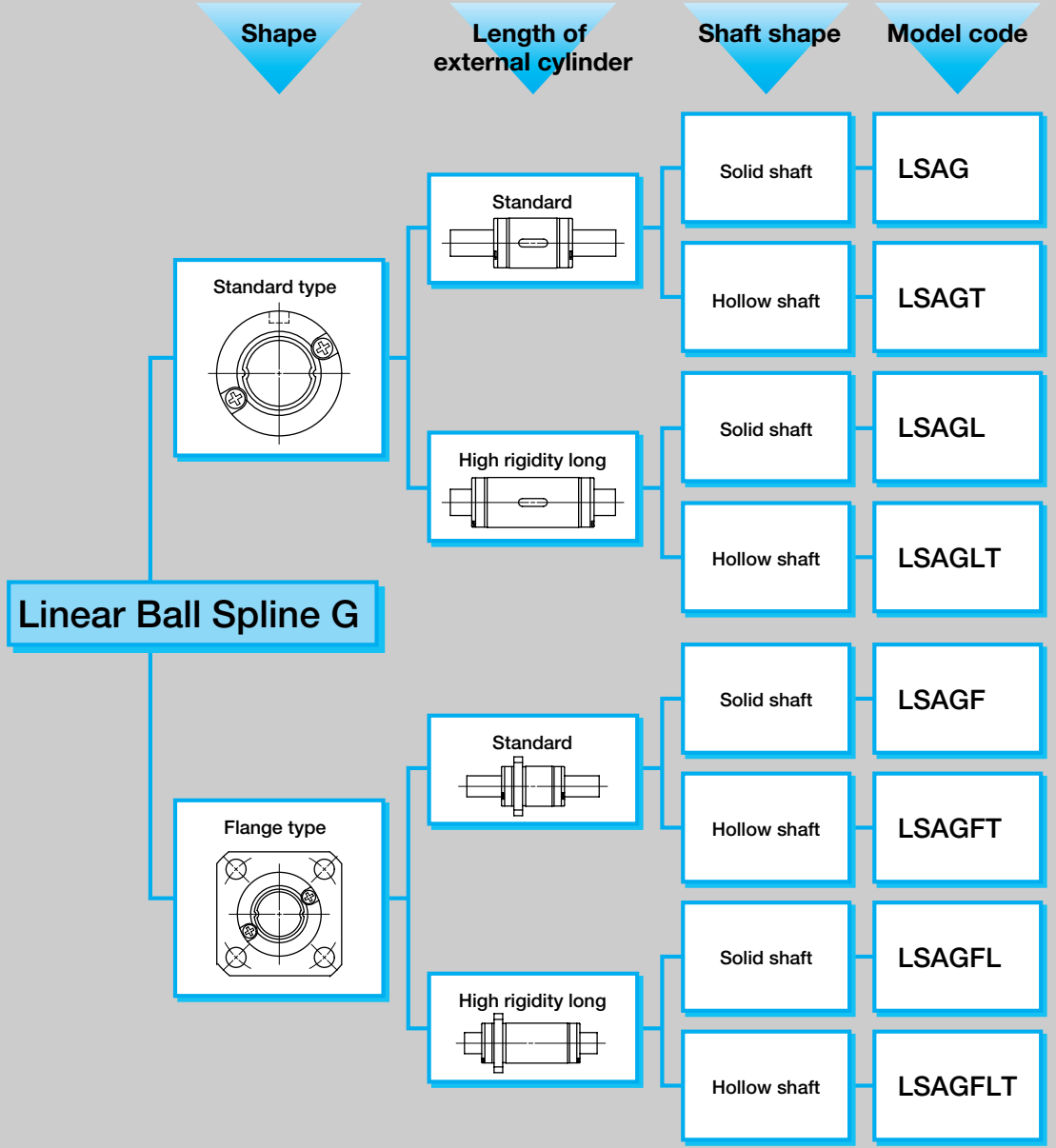

## ● Identification number and specification

The specification of Linear Ball Spline G is indicated by the identification number, consisting of a model code, a size, a part code, a preload symbol, a classification symbol, an interchangeable code and any supplemental codes. For details of each specification, see page D-6.

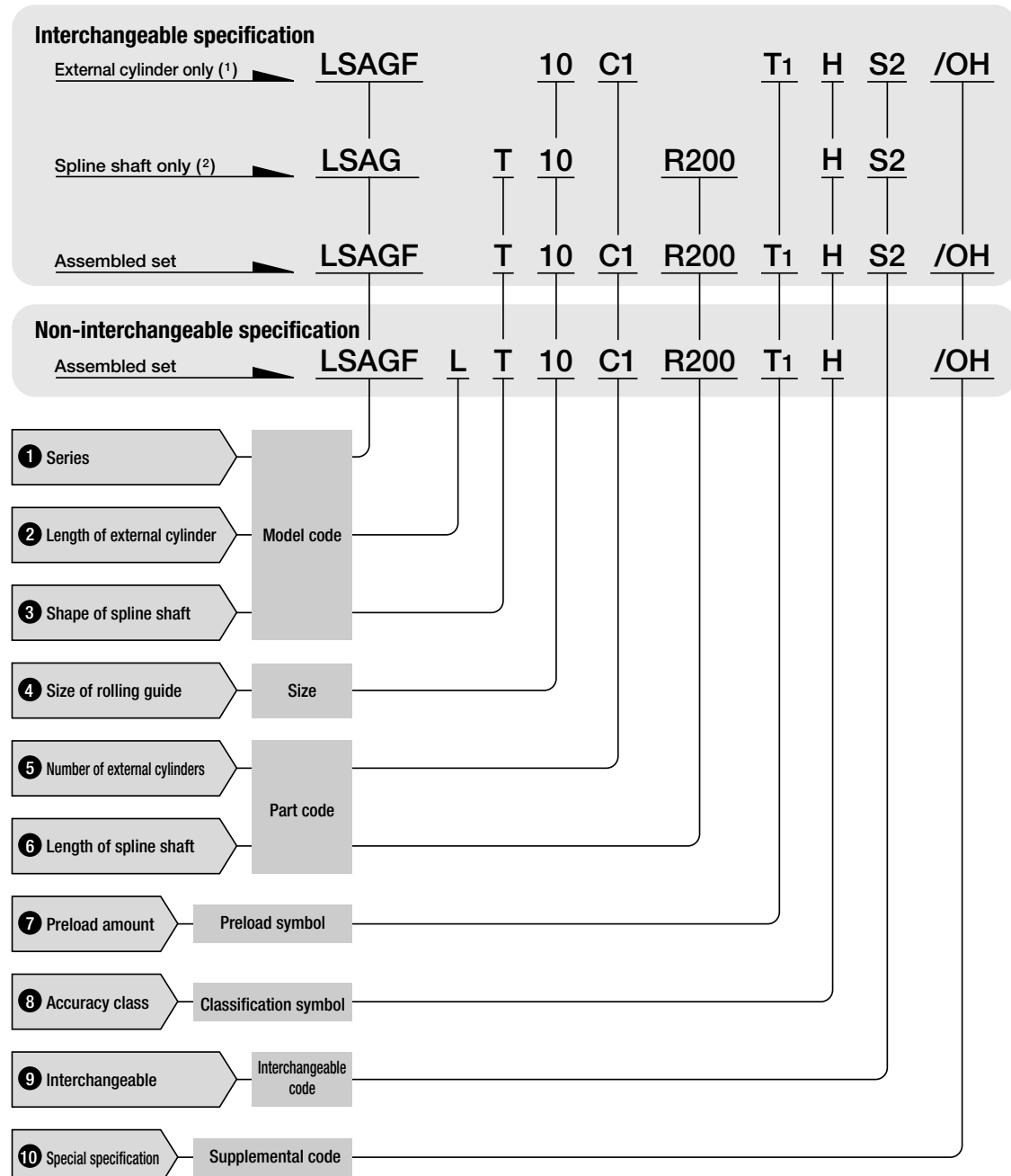

Note(1) : For the model code of a single external cylinder of interchangeable specification, indicate "LSAG" (standard type) or "LSAGF" (flange type) regardless of the spline shaft type to be combined.

(2) : For the model code of a single spline shaft of interchangeable specification, indicate "LSAG" (solid shaft) or "LSAGT" (hollow shaft) regardless of the external cylinder type to be combined.

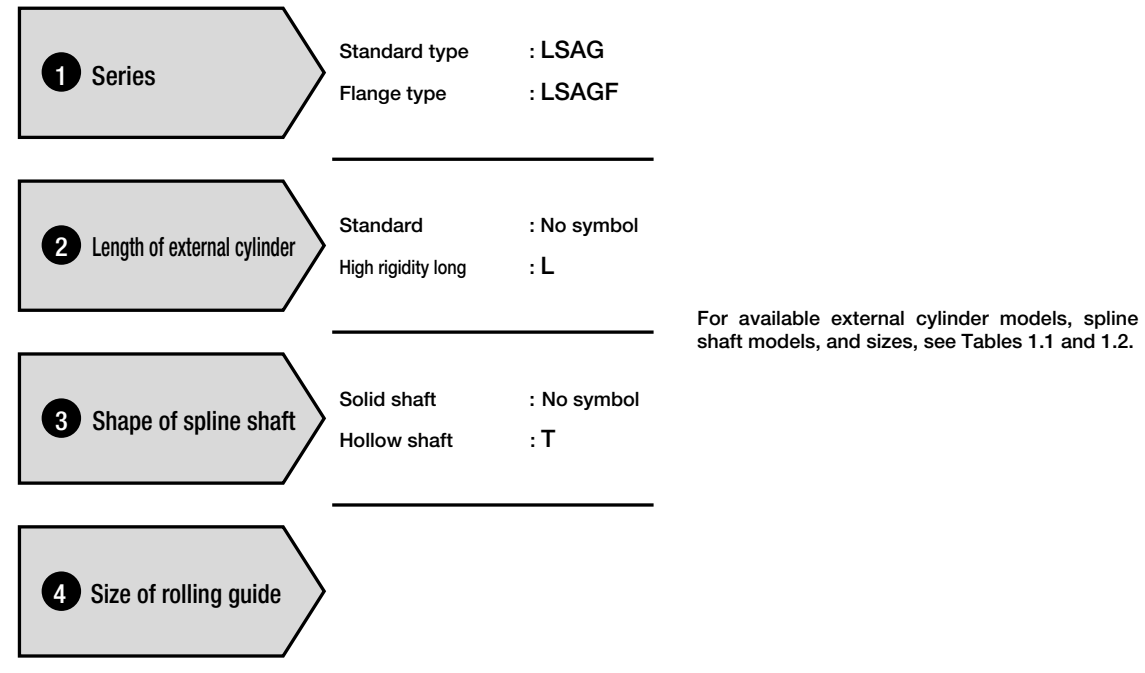

Table 1.1 Models and sizes of Linear Ball Spline G standard type

Model Size	Standard		High rigidity long	
	Solid shaft LSAG	Hollow shaft LSAGT	Solid shaft LSAGL	Hollow shaft LSAGLT
2	○	—	—	—
3	○	—	—	—
4	○	○	—	—
5	☆	☆	☆	☆
6	☆	☆	☆	☆
8	☆	☆	☆	☆
10	☆	☆	☆	☆
12	☆	☆	☆	☆
15	☆	—	☆	—
20	☆	—	☆	—
25	☆	—	☆	—
30	☆	—	☆	—
40	○	—	—	—
50	○	—	—	—

Remark : The mark ☆ indicates that interchangeable specification products are available.

Table 1.2 Models and sizes of Linear Ball Spline G flange type

Model Size	Standard		High rigidity long	
	Solid shaft LSAGF	Hollow shaft LSAGFT	Solid shaft LSAGFL	Hollow shaft LSAGFLT
2	○	—	—	—
3	○	—	—	—
4	○	○	—	—
5	☆	☆	☆	☆
6	☆	☆	☆	☆
8	☆	☆	☆	☆
10	☆	☆	☆	☆
12	☆	☆	☆	☆
15	☆	—	☆	—
20	☆	—	☆	—
25	☆	—	☆	—
30	☆	—	☆	—
40	○	—	—	—

Remark : The mark ☆ indicates that interchangeable specification products are available.

**5** Number of external cylinders

Assembled set : C○  
 External cylinder : C1  
 For an assembled set, indicate the number of external cylinders assembled on one spline shaft. For an external cylinder, only "C1" can be indicated.

**6** Length of spline shaft

Assembled set : R○  
 Spline shaft : R○  
 Indicate the length of spline shaft in mm. For standard and maximum lengths, see the table of dimensions.

**7** Preload amount

Clearance : T0  
 Standard : No symbol  
 Light preload : T1  
 Specify this item for an assembled set or a single external cylinder. For applicable preload amount, see Table 2. For details of preload amount, see page D-15.

**8** Accuracy class

Ordinary : No symbol  
 High : H  
 Precision : P  
 For applicable accuracy, see Table 3. In case of interchangeable specification products, assemble external cylinders and spline shafts of the same class. For details of accuracy, see page D-11.

Table 2 Applicable preload types

Size	Preload type (Symbol)		
	Clearance (T0)	Standard (No symbol)	Light preload (T1)
2	○	○	—
3	○	○	—
4	○	○	—
5	—	☆	☆
6	—	☆	☆
8	—	☆	☆
10	—	☆	☆
12	—	☆	☆
15	—	☆	☆
20	—	☆	☆
25	—	☆	☆
30	—	☆	☆
40	—	○	○
50	—	○	○

Remark : The mark ☆ indicates that it is also applicable to interchangeable specification products.

Table 3 Applicable accuracy classes

Size	Accuracy class (Symbol)		
	Ordinary (No symbol)	High (H)	Precision (P)
2	○	○	○
3	○	○	○
4	○	○	○
5	☆	☆	○
6	☆	☆	○
8	☆	☆	○
10	☆	☆	○
12	☆	☆	○
15	☆	☆	○
20	☆	☆	○
25	☆	☆	○
30	☆	☆	○
40	○	○	○
50	○	○	○

Remark : The mark ☆ indicates that it is also applicable to interchangeable specification products.

**9 Interchangeable code**

Select group 1 : S1  
Select group 2 : S2

Specify this item for interchangeable specification products. Assemble external cylinders and spline shafts with the same interchangeable code. Performance and accuracy of "S1" group and "S2" group are the same.

**10 Special specification**

For applicable special specifications, see Table 4. When several special specifications are combined, see Table 5. For details of special specifications, see page D-16.

Table 4 Special specifications

Special specifications	Supplemental code	Assembled set	External cylinder only	Spline shaft only	Dimension
With stainless steel end plates	BS	○ (1)	—	—	
No end seal	N	☆ (2)	☆	—	
Oil hole	OH	☆ (3)	☆ (3)	—	See Table 6.1 and 6.2.
Capillary plates	Q	☆ (4)	☆ (4)	—	See Table 7.
Seal for special environment	RE	○ (1)	—	—	
Spline shaft in stainless steel	S	○ (5)(6)	—	—	
Specified grease	Y	○ (1)	—	—	

Note(1) : Applicable to size 5, 6, 8, 10, 12 and 15 models.  
 (2) : Not applicable to size 2, 3 and 4 models.  
 (3) : Not applicable to size 2 models.  
 (4) : Applicable to size 5, 6, 8, 10 and 12 models.  
 (5) : Not applicable to size 2, 3, 4, 40 and 50 models.  
 (6) : Not applicable to the hollow shaft.

Remark : In the table, the mark ☆ indicates that it is also applicable to interchangeable specification products.

Table 5 Combination of special specifications

N	○						
OH	○	☆					
Q	○	☆	☆				
RE	○	—	○	○			
S	○	○	○	○	○		
Y	○	○	○	—	○	○	
	BS	N	OH	Q	RE	S	

Remark 1 : The mark ☆ indicates that it is also applicable to interchangeable specification products.  
 2 : In the table, the mark — indicates that this combination cannot be made.  
 3 : When several special specifications are required, arrange the supplemental codes alphabetically.

Table 6.1 Location and diameter of oil hole for standard type external cylinder (Supplemental code /OH)

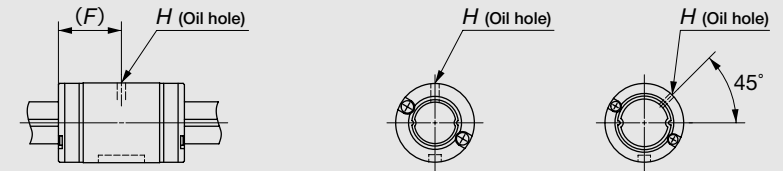

LSAG 40 unit : mm

Model number	F	H	Model number	F	H
LSAG 3	5	1.2	LSAG 15	20	2
LSAG 4	6	1.5	LSAG 20	25	3
LSAG 5	9		LSAG 25	30	
LSAG 6	10.5		LSAG 30	35	
LSAG 8	12.5		LSAG 40	50	
LSAG 10	15	2	LSAG 50	—	—
LSAG 12	17.5		—	—	—

Model number	F	H	Model number	F	H
—	—	—	LSAGL 15	32.5	2
—	—	—	LSAGL 20	35.5	3
LSAGL 5	13	1.5	LSAGL 25	42	
LSAGL 6	15		LSAGL 30	49	
LSAGL 8	18.5		—	—	—
LSAGL 10	23.5	2	—	—	—
LSAGL 12	27		—	—	—

Remark : Also applicable to assembled sets of LSAGT and LSAGLT.

Table 6.2 Location and diameter of oil hole for flange type external cylinder (Supplemental code /OH)

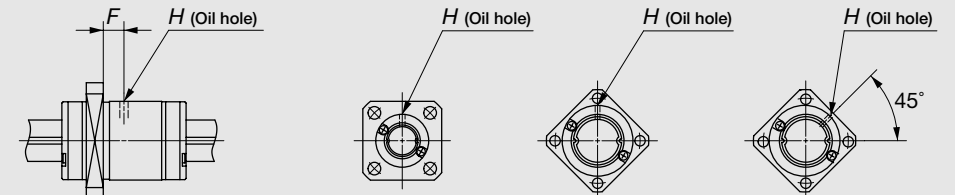

LSAGF (L) 30 LSAGF 40 unit : mm

Model number	F	H	Model number	F	H
LSAGF 3	2.1	1.2	LSAGF 12	7.5	2
LSAGF 4	2.8	1.5	LSAGF 15	9	
LSAGF 5	2.8		LSAGF 20	11	3
LSAGF 6	3.5		LSAGF 25	13	
LSAGF 8	3.5		LSAGF 30	14	
LSAGF 10	5	2	LSAGF 40	23.4	—

  

Model number	F	H	Model number	F	H
—	—	—	LSAGFL 12	17	2
—	—	—	LSAGFL 15	21.4	
LSAGFL 5	5.8	1.5	LSAGFL 20	21.5	3
LSAGFL 6	8		LSAGFL 25	25	
LSAGFL 8	9.5		LSAGFL 30	28	
LSAGFL 10	13.3	2	—	—	—

Remark : Also applicable to assembled sets of LSAGFT and LSAGFLT.



Table 7 External cylinder with Capillary plates (Supplemental code /Q)

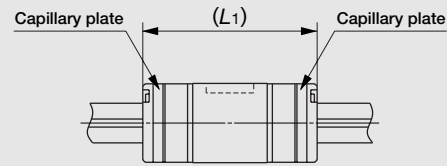

Model number	L1	Model number	L1
LSAG 5	24	LSAG 10	38
LSAGL 5	32	LSAGL 10	55
LSAG 6	27	LSAG 12	43
LSAGL 6	36	LASGL 12	62
LSAG 8	33		
LASGL 8	45		

### Moment of inertia of sectional area and section modulus of spline shaft

Moment of inertia of sectional area and section modulus of the spline shaft are shown in Table 8.

Table 8 Moment of inertia of sectional area and section modulus of spline shaft

Size	Moment of inertia of sectional area mm <sup>4</sup>		Section modulus mm <sup>3</sup>	
	Solid shaft	Hollow shaft	Solid shaft	Hollow shaft
2	0.60	—	0.65	—
3	3.6	—	2.5	—
4	12	12	6	6
5	29	29	12	12
6	61	61	21	21
8	190	190	49	49
10	470	460	95	94
12	990	960	170	160
15	1 590	—	240	—
20	5 110	—	570	—
25	12 100	—	1 080	—
30	25 400	—	1 890	—
40	91 000	—	4 930	—
50	223 000	—	9 660	—

### Dimensions of key

The keys shown in Table 9 are appended to Linear Ball Spline G standard type. However, no keys are appended to LSAG2, LSAG3, LSAG4 and LSAGT4. For details of fixing, see page D-21.

Table 9 Dimensions of key

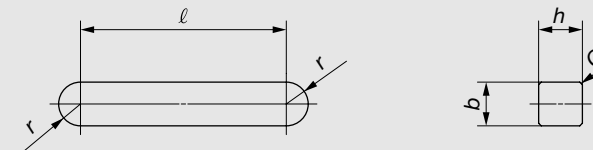

unit : mm

Model number	b	Tolerance	h	Tolerance	l	r	C
LSAG 5	2	+0.016 +0.006	2	0 -0.025	3.8	1	0.16~0.25
LSAG 6			2.5		5.8	1.25	
LSAG 8	3	3	7.8	1.5			
LSAG 10	3	3	11.8	1.5			
LSAG 12	3.5	+0.024 +0.012	3.5	0 -0.030	16	1.75	0.25~0.4
LSAG 15	4		4		21.5	2	
LSAG 20	5	5	23.5	2.5			
LSAG 25	7	+0.030 +0.015	7	0 -0.036	27.5	3.5	0.4 ~0.6
LSAG 30	10		8		44.3	5	
LSAG 40	15	+0.036 +0.018	10		34.3	7.5	

Remark : The above table shows representative model numbers but is applicable to all standard types of the same size.

# IKO Linear Ball Spline G : Standard type

LSAG • LSAGT • LSAGL • LSAGLT

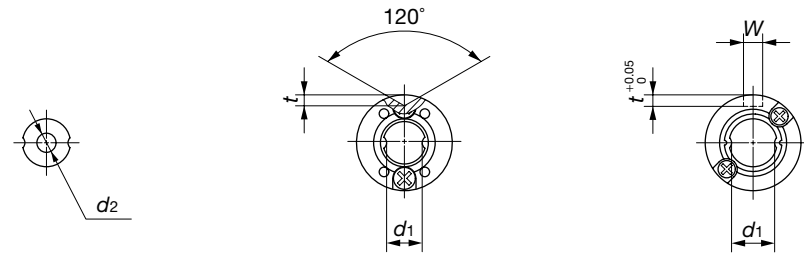

LSAG 2  
LSAGT 3  
LSAGL(T) 4

Bore dia. of hollow shaft

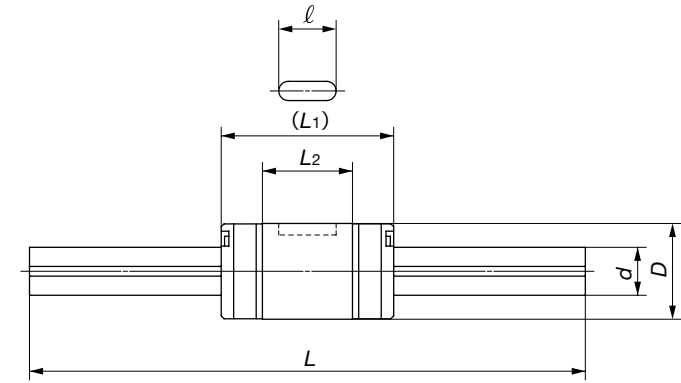

Model number	Interchangeable	Mass (Ref.) g		Dimensions and tolerances of external cylinder mm							
		External cylinder	Spline shaft (per 100 mm)	D	Tolerance	L <sub>1</sub>	L <sub>2</sub>	W	Tolerance	t	ℓ
LSAG 2(1)		1.0	2.3	6	$\begin{matrix} 0 \\ -0.008 \end{matrix}$	8.5	4.7	—	—	0.7	—
LSAG 3(1)		2.1	5.4	7	$\begin{matrix} 0 \\ -0.009 \end{matrix}$	10	5.9	—	—	0.8	—
LSAG 4(1)		2.5	9.6	8	$\begin{matrix} 0 \\ -0.009 \end{matrix}$	12	7.9	—	—	1	—
LSAGT 4(1)			8.2								
LSAG 5	☆	4.8	14.9	10	$\begin{matrix} 0 \\ -0.009 \end{matrix}$	18	9.4	2	$\begin{matrix} +0.014 \\ 0 \end{matrix}$	1.2	6
LSAGT 5	☆		12.4								
LSAGL 5	☆	7.9	14.9			26	16.9	2	$\begin{matrix} +0.014 \\ 0 \end{matrix}$	1.2	8
LSAGLT 5	☆		12.4								
LSAG 6	☆	8.9	19	12	$\begin{matrix} 0 \\ -0.011 \end{matrix}$	21	12.4	2	$\begin{matrix} +0.014 \\ 0 \end{matrix}$	1.2	8
LSAGT 6	☆		16.5								
LSAGL 6	☆	14.5	19			30	21.4	2	$\begin{matrix} +0.014 \\ 0 \end{matrix}$	1.2	8
LSAGLT 6	☆		16.5								
LSAG 8	☆	15.9	39	15	$\begin{matrix} 0 \\ -0.011 \end{matrix}$	25	14.6	2.5	$\begin{matrix} +0.014 \\ 0 \end{matrix}$	1.5	8.5
LSAGT 8	☆		33								
LSAGL 8	☆	26.5	39			37	26.6	2.5	$\begin{matrix} +0.014 \\ 0 \end{matrix}$	1.5	8.5
LSAGLT 8	☆		33								

Note(1) : No seals are attached.

(2) : Dimension d<sub>1</sub> indicates the maximum diameter when machining is done at the shaft ends.

(3) : This length is the standard length. Spline shafts in other length are also available. Simply indicate the necessary length of spline shaft in mm in the identification number.

(4) : The directions of basic dynamic load rating (C), basic static load rating (C<sub>0</sub>), dynamic torque rating (T) and static torque/moment rating (T<sub>0</sub>, T<sub>x</sub>, T<sub>y</sub>) are shown in the sketches below.

The upper values in the T<sub>x</sub> and T<sub>y</sub> columns apply to one external cylinder, and the lower values apply to two external cylinders in close contact.

Remark : The mark ☆ indicates that interchangeable specification products are available.

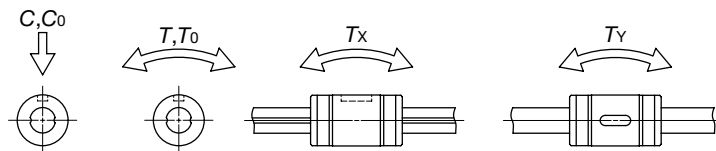

Dimensions and tolerance of spline shaft mm						Basic dynamic load rating <sup>(4)</sup>	Basic static load rating <sup>(4)</sup>	Dynamic torque rating <sup>(4)</sup>	Static torque rating <sup>(4)</sup>	Static moment rating <sup>(4)</sup>	
d	Tolerance	d <sub>1</sub> <sup>(2)</sup>	d <sub>2</sub>	L <sup>(3)</sup>	Maximum length	C	C <sub>0</sub>	T	T <sub>0</sub>	T <sub>x</sub>	T <sub>y</sub>
2	$\begin{matrix} 0 \\ -0.010 \end{matrix}$	1.2	—	50 100	100	222	237	0.28	0.30	0.22 1.6	0.39 2.9
3	$\begin{matrix} 0 \\ -0.010 \end{matrix}$	2.2	—	100 150	150	251	285	0.45	0.51	0.31 1.9	0.53 3.3
4	$\begin{matrix} 0 \\ -0.012 \end{matrix}$	3.2	—	100 150	200	303	380	0.70	0.87	0.52 2.9	0.90 5.0
			1.5								
5	$\begin{matrix} 0 \\ -0.012 \end{matrix}$	4.2	—	100 150	200	587	641	1.8	1.9	1.0 7.9	1.8 13.6
			2								
			—								
6	$\begin{matrix} 0 \\ -0.012 \end{matrix}$	5.2	—	150 200	300	711	855	2.5	3.0	1.7 11.7	3.0 20.3
			2								
			—								
8	$\begin{matrix} 0 \\ -0.015 \end{matrix}$	7	—	150 200	500	1 190	1 330	5.5	6.2	3.3 22.0	5.6 38.1
			3								
			—								
			250								
8	$\begin{matrix} 0 \\ -0.015 \end{matrix}$	7	—	150 200	500	1 800	2 470	8.4	11.5	10.3 56.3	17.8 97.5
			3								

Example of identification number of assembled set (For details, see "Identification number and specification".)

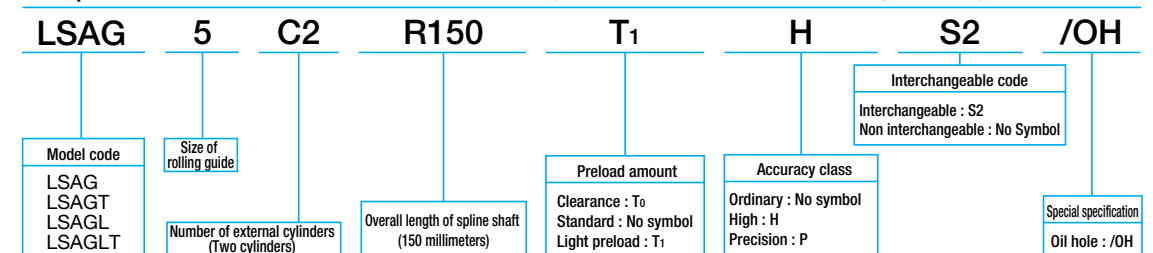

# IKO Linear Ball Spline G : Standard type

LSAG • LSAGT • LSAGL • LSAGLT



Bore dia. of hollow shaft

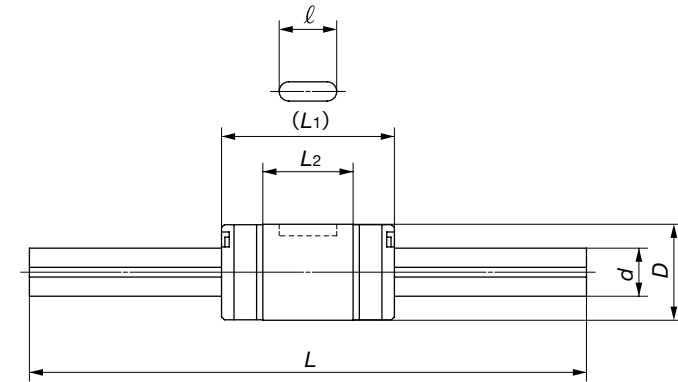

Model number	Interchangeable	Mass (Ref.) g		Dimensions and tolerances of external cylinder mm								d	Tolerance
		External cylinder	Spline shaft (per 100 mm)	D	Tolerance	L <sub>1</sub>	L <sub>2</sub>	W	Tolerance	t	l		
LSAG 10	☆	31.5	60.5	19	0 -0.013	30	18.2	3	+0.014 0	1.8	11	10	0 -0.015
LSAGT 10	☆		51										
LSAGL 10	☆	56.5	60.5	19	0 -0.013	47	34.9	3	+0.014 0	1.8	11	10	0 -0.015
LSAGLT 10	☆		51										
LSAG 12	☆	44	87.5	21	0 -0.013	35	23	3	+0.014 0	1.8	15	12	0 -0.018
LSAGT 12	☆		66										
LSAGL 12	☆	76.8	87.5	21	0 -0.013	54	42	3	+0.014 0	1.8	15	12	0 -0.018
LSAGLT 12	☆		66										
LSAG 15	☆	59.5	111	23	0 -0.013	40	27	3.5	+0.018 0	2	20	13.6	0 -0.018
LSAGL 15	☆	110											
LSAG 20	☆	130	202	30	0 -0.016	50	33	4	+0.018 0	2.5	26	18.2	0 -0.021
LSAGL 20	☆	198											
LSAG 25	☆	220	310	37	0 -0.016	60	39.2	5	+0.018 0	3	29	22.6	0 -0.021
LSAGL 25	☆	336											
LSAG 30	☆	430	450	45	0 -0.016	70	43	7	+0.022 0	4	35	27.2	0 -0.021
LSAGL 30	☆	634											
LSAG 40		760	808	60	0 -0.019	100	70.8	10	+0.022 0	4.5	55	37.2	0 -0.025
LSAG 50		1 140	1 320	75	0 -0.019	100	66.4	15	+0.027 0	5	50	46.6	0 -0.025

Note(1) : Dimension  $d_1$  indicates the maximum diameter when machining is done at the shaft ends.  
 (2) : This length is the standard length. Spline shafts in other length are also available. Simply indicate the necessary length of spline shaft in the identification number.  
 (3) : The directions of basic dynamic load rating (C), basic static load rating (C<sub>0</sub>), dynamic torque rating (T) and static torque/moment rating (T<sub>0</sub>, T<sub>x</sub>, T<sub>y</sub>) are shown in the sketches below.  
 The upper values in the T<sub>x</sub> and T<sub>y</sub> columns apply to one external cylinder, and the lower values apply to two external cylinders in close contact.  
 Remark : The mark ☆ indicates that interchangeable specification products are available.

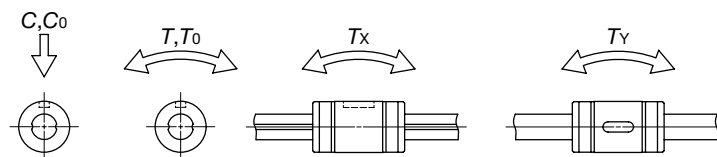

Dimensions and tolerance of spline shaft mm				Basic dynamic load rating <sup>(3)</sup>	Basic static load rating <sup>(3)</sup>	Dynamic torque rating <sup>(3)</sup>	Static torque rating <sup>(3)</sup>	Static moment rating <sup>(3)</sup>			
d <sub>1</sub> <sup>(1)</sup>	d <sub>2</sub>	L <sup>(2)</sup>		C	C <sub>0</sub>	T	T <sub>0</sub>	T <sub>x</sub>	T <sub>y</sub>		
				N	N	N·m	N·m	N·m	N·m		
8.9	—	200	300	600	1 880	2 150	10.9	12.5	7.0	12.1	
	4								41.5	71.9	
	—								22.7	39.3	
10.9	—	200	300	400	800	2 180	2 690	14.8	18.3	10.6	18.3
	6									59.1	102
	—									32.2	55.7
11.6	—	200	300	400	1 000	4 180	6 070	31.3	45.6	27.8	33.2
	—									152	181
	—									94.0	112
15.7	—	300	400	500	1 000	6 600	9 040	66.0	90.4	48.6	58.0
	—									288	343
	—									127	151
19.4	—	300	400	500	1 200	11 200	14 300	139	178	92.8	111
	—									551	656
	—									229	273
23.5	—	400	500	600	1 200	15 400	19 400	231	292	147	176
	—									874	1 040
	—									364	434
33.5	—	400	500	600	1 200	21 300	31 600	320	474	1 900	2 260
	—									364	434
	—									1 940	2 310
42.0	—	400	500	600	1 200	28 300	36 100	707	904	389	464
	—									2 300	2 740
	—									2 300	2 740

Example of identification number of assembled set (For details, see "Identification number and specification".)

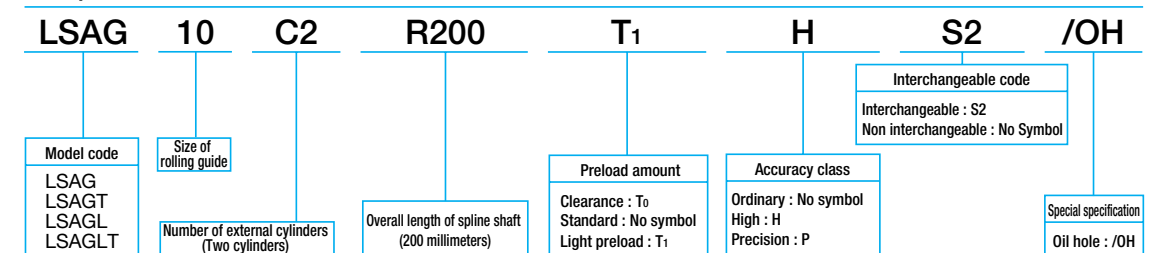

1N=0.102kgf=0.2248lbs.  
1mm=0.03937inch

# IKO Linear Ball Spline G : Flange type

LSAGF • LSAGFT • LSAGFL • LSAGFLT

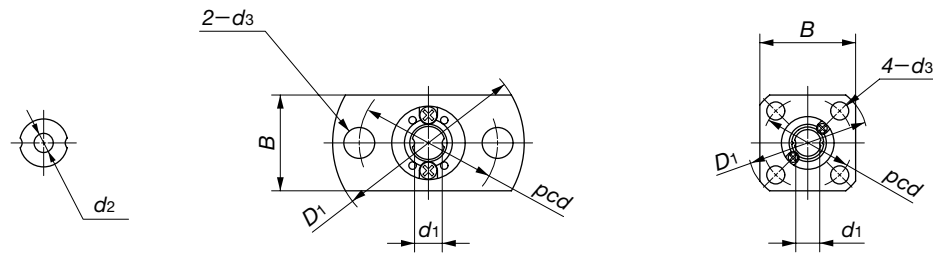

Bore dia. of hollow shaft

LSAGF 2  
LSAGFT 3  
LSAGFL(T) 4

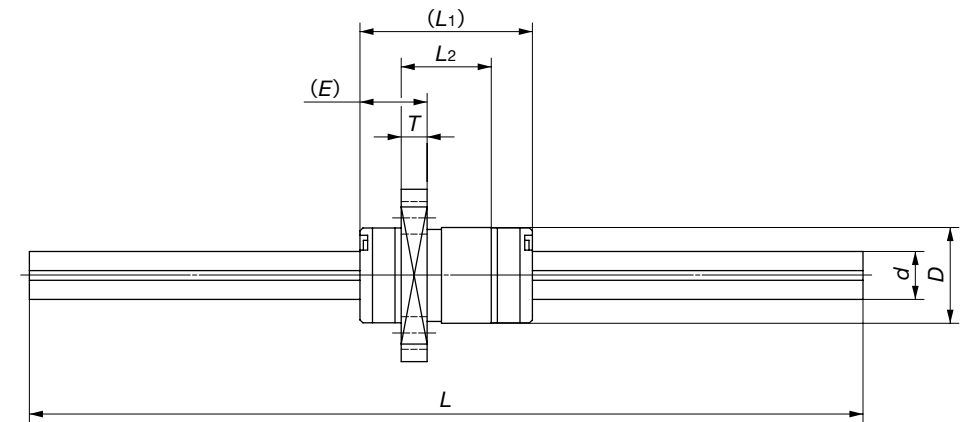

Model number	Interchangeable	Mass (Ref.) g		Dimensions and tolerance of external cylinder mm									
		External cylinder	Spline shaft (per 100 mm)	D	Tolerance	L <sub>1</sub>	L <sub>2</sub>	D <sub>1</sub>	B	E	T	pcd	d <sub>3</sub>
LSAGF 2 <sup>(1)</sup>		1.9	2.3	6	$\begin{matrix} 0 \\ -0.008 \end{matrix}$	8.5	4.7	15.5	8	3.4	1.5	11	2.4
LSAGF 3 <sup>(1)</sup>		3.7	5.4	7	$\begin{matrix} 0 \\ -0.009 \end{matrix}$	10	5.9	18	9	4	1.9	13	2.9
LSAGF 4 <sup>(1)</sup>		5.1	9.6	8	$\begin{matrix} 0 \\ -0.009 \end{matrix}$	12	7.9	21	10	4.6	2.5	15	3.4
LSAGFT 4 <sup>(1)</sup>			8.2										
LSAGF 5	☆	8.9	14.9	10	$\begin{matrix} 0 \\ -0.009 \end{matrix}$	18	9.4	23	18	7	2.7	17	3.4
LSAGFT 5	☆		12.4										
LSAGFL 5	☆	12	14.9	26	16.9	21	12.4	25	20	7	2.7	19	3.4
LSAGFLT 5	☆		12.4										
LSAGF 6	☆	13.9	19	12	$\begin{matrix} 0 \\ -0.011 \end{matrix}$	21	12.4	25	20	7	2.7	19	3.4
LSAGFT 6	☆		16.5										
LSAGFL 6	☆	19.5	19	30	21.4	25	12.4	25	20	7	2.7	19	3.4
LSAGFLT 6	☆		16.5										
LSAGF 8	☆	23.5	39	15	$\begin{matrix} 0 \\ -0.011 \end{matrix}$	25	14.6	28	22	9	3.8	22	3.4
LSAGFT 8	☆		33										
LSAGFL 8	☆	34.1	39	37	26.6	25	14.6	28	22	9	3.8	22	3.4
LSAGFLT 8	☆		33										

Note<sup>(1)</sup> : No seals are attached.

<sup>(2)</sup> : Dimension d<sub>1</sub> indicates the maximum diameter when machining is done at the shaft ends.

<sup>(3)</sup> : This length is the standard length. Spline shafts in other length are also available. Simply indicate the necessary length of spline shaft in mm in the identification number.

<sup>(4)</sup> : The directions of basic dynamic load rating (C), basic static load rating (C<sub>0</sub>), dynamic torque rating (T) and static torque/moment rating (T<sub>0</sub>, T<sub>x</sub>, T<sub>y</sub>) are shown in the sketches below.

The upper values in the T<sub>x</sub> and T<sub>y</sub> columns apply to one external cylinder, and the lower values apply to two external cylinders in close contact.

Remark : The mark ☆ indicates that interchangeable specification products are available.

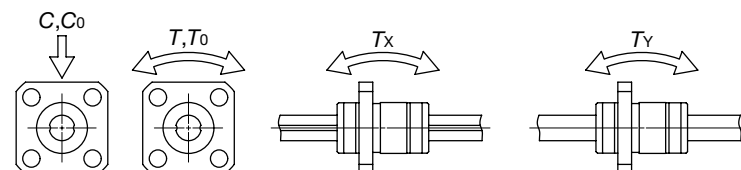

Dimensions and tolerance of spline shaft mm						Basic dynamic load rating <sup>(4)</sup>	Basic static load rating <sup>(4)</sup>	Dynamic torque rating <sup>(4)</sup>	Static torque rating <sup>(4)</sup>	Static moment rating <sup>(4)</sup>							
d	Tolerance	d <sub>1</sub> <sup>(2)</sup>	d <sub>2</sub>	L <sup>(3)</sup>	Maximum length	C	C <sub>0</sub>	T	T <sub>0</sub>	T <sub>x</sub>	T <sub>y</sub>						
						N	N	N·m	N·m	N·m	N·m						
2	$\begin{matrix} 0 \\ -0.010 \end{matrix}$	1.2	—	50 100	100	222	237	0.28	0.30	0.22 1.6	0.39 2.9						
3	$\begin{matrix} 0 \\ -0.010 \end{matrix}$	2.2	—	100 150	150	251	285	0.45	0.51	0.31 1.9	0.53 3.3						
4	$\begin{matrix} 0 \\ -0.012 \end{matrix}$	3.2	—	100 150	200	303	380	0.70	0.87	0.52 2.9	0.90 5.0						
			1.5		150												
5	$\begin{matrix} 0 \\ -0.012 \end{matrix}$	4.2	—	100 150	200	587	641	1.8	1.9	1.0 7.9	1.8 13.6						
			2									879	1 180	2.6	3.5	3.2 19.3	5.5 33.4
			—														
6	$\begin{matrix} 0 \\ -0.012 \end{matrix}$	5.2	—	150 200	300	711	855	2.5	3.0	1.7 11.7	3.0 20.3						
			2									1 030	1 500	3.6	5.2	5.0 27.6	8.6 47.8
			—														
8	$\begin{matrix} 0 \\ -0.015 \end{matrix}$	7	—	150 200 250	500	1 190	1 330	5.5	6.2	3.3 22.0	5.6 38.1						
			3		1 800							2 470	8.4	11.5	10.3 56.3	17.8 97.5	
			—														
			3														

Example of identification number of assembled set (For details, see "Identification number and specification".)

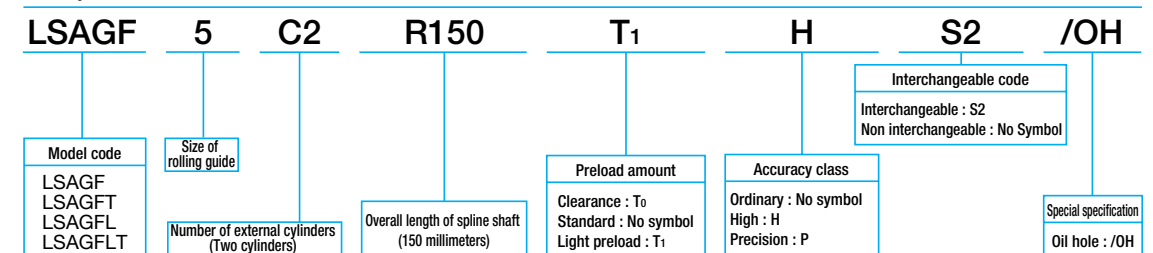

# IKO Linear Ball Spline G : Flange type

LSAGF • LSAGFT • LSAGFL • LSAGFLT

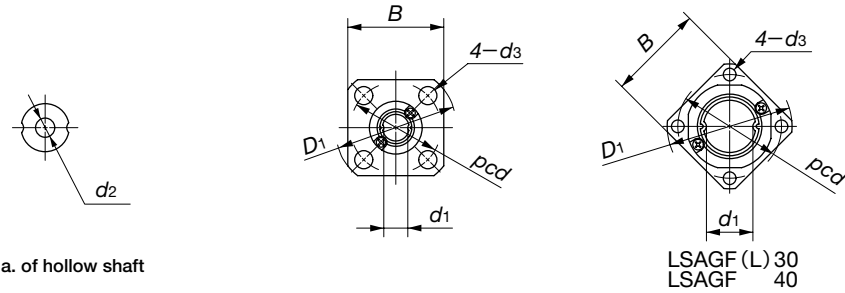

Bore dia. of hollow shaft

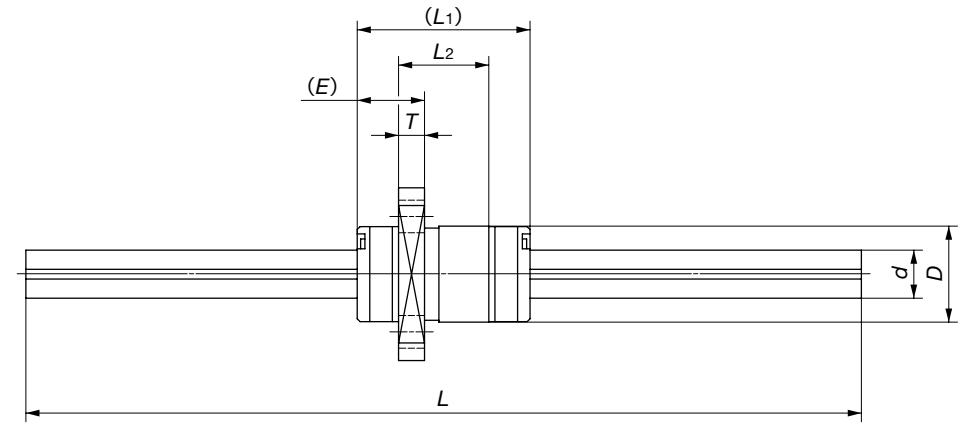

Model number	Interchangeable	Mass (Ref.) g		Dimensions and tolerance of external cylinder mm											
		External cylinder	Spline shaft (per 100 mm)	D	Tolerance	L <sub>1</sub>	L <sub>2</sub>	D <sub>1</sub>	B	E	T	pcd	d <sub>3</sub>	d	Tolerance
LSAGF 10	☆	45	60.5	19	0 -0.013	30	18.2	36	28	10	4.1	28	4.5	10	0 -0.015
LSAGFT 10	☆		51			47	34.9								
LSAGFL 10	☆	70.1	60.5	21	0 -0.013	35	23	38	30	10	4	30	4.5	12	0 -0.018
LSAGFLT 10	☆		51			54	42								
LSAGF 12	☆	59	87.5	23	0 -0.013	40	27	40	31	11	4.5	32	4.5	13.6	0 -0.018
LSAGFT 12	☆		66			65	52								
LSAGFL 12	☆	91.8	87.5	30	0 -0.016	50	33	46	35	14	5.5	38	4.5	18.2	0 -0.021
LSAGFLT 12	☆		66			71	54								
LSAGF 15	☆	77	111	37	0 -0.016	60	39.2	57	43	17	6.6	47	5.5	22.6	0 -0.021
LSAGFL 15	☆		128			84	63.2								
LSAGF 20	☆	150	202	45	0 -0.016	70	43	65	50	21	7.5	54	6.6	27.2	0 -0.021
LSAGFL 20	☆		218			98	71								
LSAGF 25	☆	255	310	60	0 -0.019	100	70.8	93	73	26.6	12	73	9	37.2	0 -0.025
LSAGFL 25	☆		371			98	71								
LSAGF 30	☆	476	450	60	0 -0.019	100	70.8	93	73	26.6	12	73	9	37.2	0 -0.025
LSAGFL 30	☆		680			98	71								
LSAGF 40	☆	962	808	60	0 -0.019	100	70.8	93	73	26.6	12	73	9	37.2	0 -0.025

Note(1) : Dimension d<sub>1</sub> indicates the maximum diameter when machining is done at the shaft ends.

(2) : This length is the standard length. Spline shafts in other length are also available. Simply indicate the necessary length of spline shaft in mm in the identification number.

(3) : The directions of basic dynamic load rating (C), basic static load rating (C<sub>0</sub>), dynamic torque rating (T) and static torque/moment rating (T<sub>0</sub>, T<sub>x</sub>, T<sub>y</sub>) are shown in the sketches below.

The upper values in the T<sub>x</sub> and T<sub>y</sub> columns apply to one external cylinder, and the lower values apply to two external cylinders in close contact.

Remark : The mark ☆ indicates that interchangeable specification products are available.

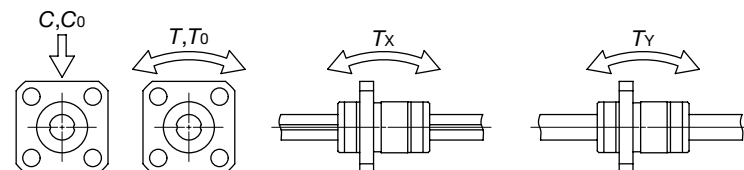

Dimensions and tolerance of spline shaft mm				Basic dynamic load rating <sup>(3)</sup> C N	Basic static load rating <sup>(3)</sup> C <sub>0</sub> N	Dynamic torque rating <sup>(3)</sup> T N·m	Static torque rating <sup>(3)</sup> T <sub>0</sub> N·m	Static moment rating <sup>(3)</sup>		
d <sub>1</sub> <sup>(1)</sup>	d <sub>2</sub>	L <sup>(2)</sup>						Maximum length	T <sub>x</sub> N·m	T <sub>y</sub> N·m
8.9	—	200	300	600	1 880	2 150	10.9	12.5	7.0	12.1
	4								41.5	71.9
	—								22.7	39.3
4	115	200								
10.9	—	200	300	400	2 180	2 690	14.8	18.3	10.6	18.3
	6								59.1	102
	—								32.2	55.7
6	157	272								
11.6	—	200	300	400	4 180	6 070	31.3	45.6	27.8	33.2
	—								152	181
15.7	—	300	400	500	6 600	9 040	66.0	90.4	94.0	112
	—								449	535
19.4	—	300	400	500	9 270	15 100	92.7	151	48.6	58.0
	—								288	343
23.5	—	400	500	600	11 200	14 300	139	178	127	151
	—								620	738
33.5	—	400	500	600	15 400	19 400	231	292	92.8	111
	—								551	656
33.5	—	400	500	600	21 300	31 600	320	474	229	273
	—								1 190	1 420
33.5	—	400	500	600	15 400	19 400	231	292	147	176
	—								874	1 040
33.5	—	400	500	600	21 300	31 600	320	474	364	434
	—								1 900	2 260
33.5	—	400	500	600	21 300	31 600	426	632	364	434
	—								1 940	2 310

Example of identification number of assembled set (For details, see "Identification number and specification".)

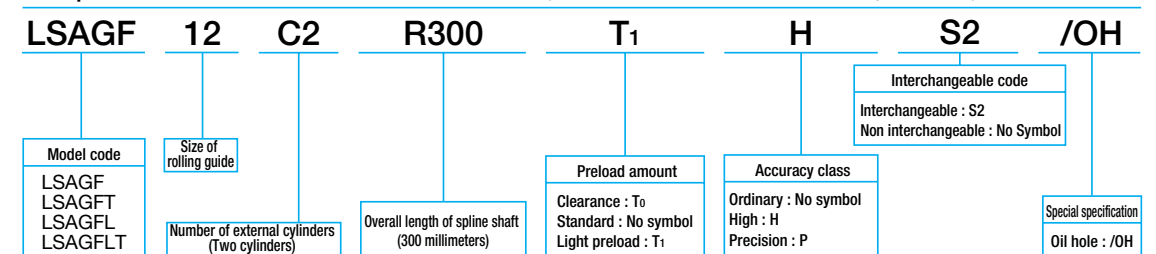

# Block type Linear Ball Spline

LSB

**IICO** Block type Linear Ball Spline is a linear motion rolling guide, featuring a slide unit which performs endless linear motion along a spline shaft. Two rows of steel balls are arranged in four point contact with the raceways. This design ensures stable high accuracy and rigidity in operations even under fluctuating loads with changing direction and magnitude or complex loads.

## Interchangeable

All models in this series are interchangeable specification products. The dimensions of slide units and spline shafts are individually controlled, so that the spline shafts and slide units can be combined, added or exchanged freely.

## Stainless steel type

The stainless steel type has excellent corrosion resistance and is most suitable for machines and equipment used in clean environments, for example, medical equipment, measuring instruments, and semiconductor manufacturing equipment.

## Easy mounting

The slide unit is provided with threaded mounting holes for easy mounting on machines or equipment with bolts.

## Hollow shaft

In high carbon steel type, hollow shafts are also available in addition to solid shafts. The hollow shafts are suitable for applications in which piping, wiring or ventilation is needed.

U.S. PATENT No.5,490,729  
No.4,505,522

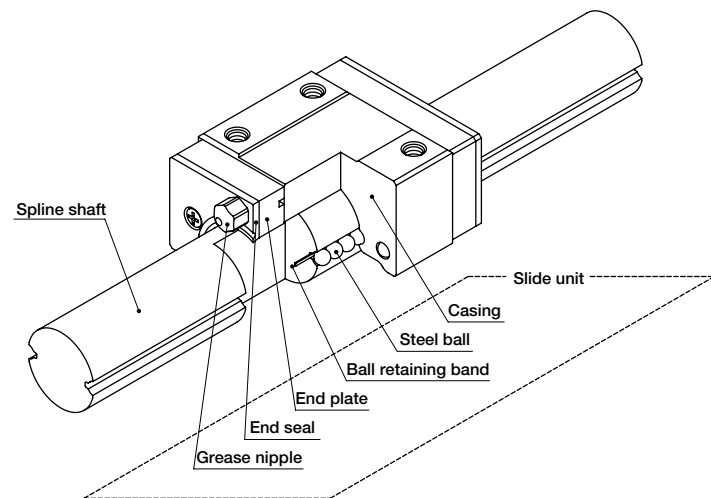

Structure of Block type Linear Ball Spline

## Block type Linear Ball Spline series

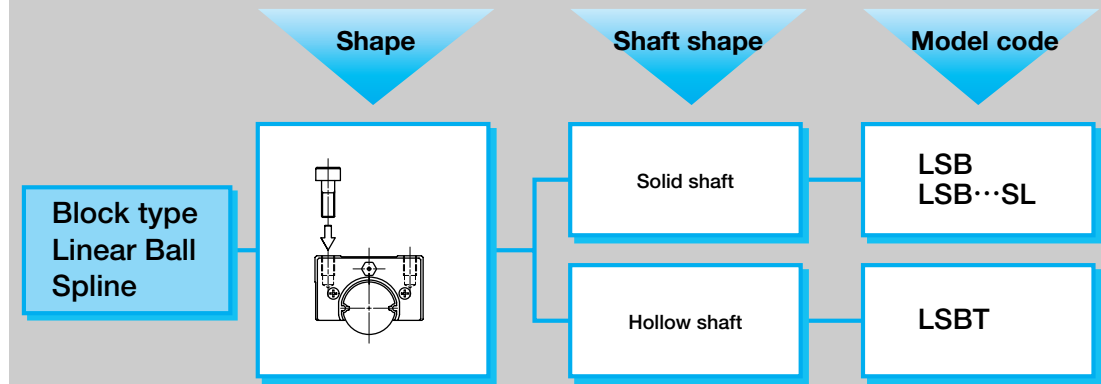

Remark : Models with "SL" are stainless steel type.

## Identification number and specification

The specification of Block type Linear Ball Spline is indicated by the identification number, consisting of a model code, a size, a part code, a material symbol, a preload symbol, a classification symbol, an interchangeable code and any supplemental codes. For details of each specification, see page D-6.

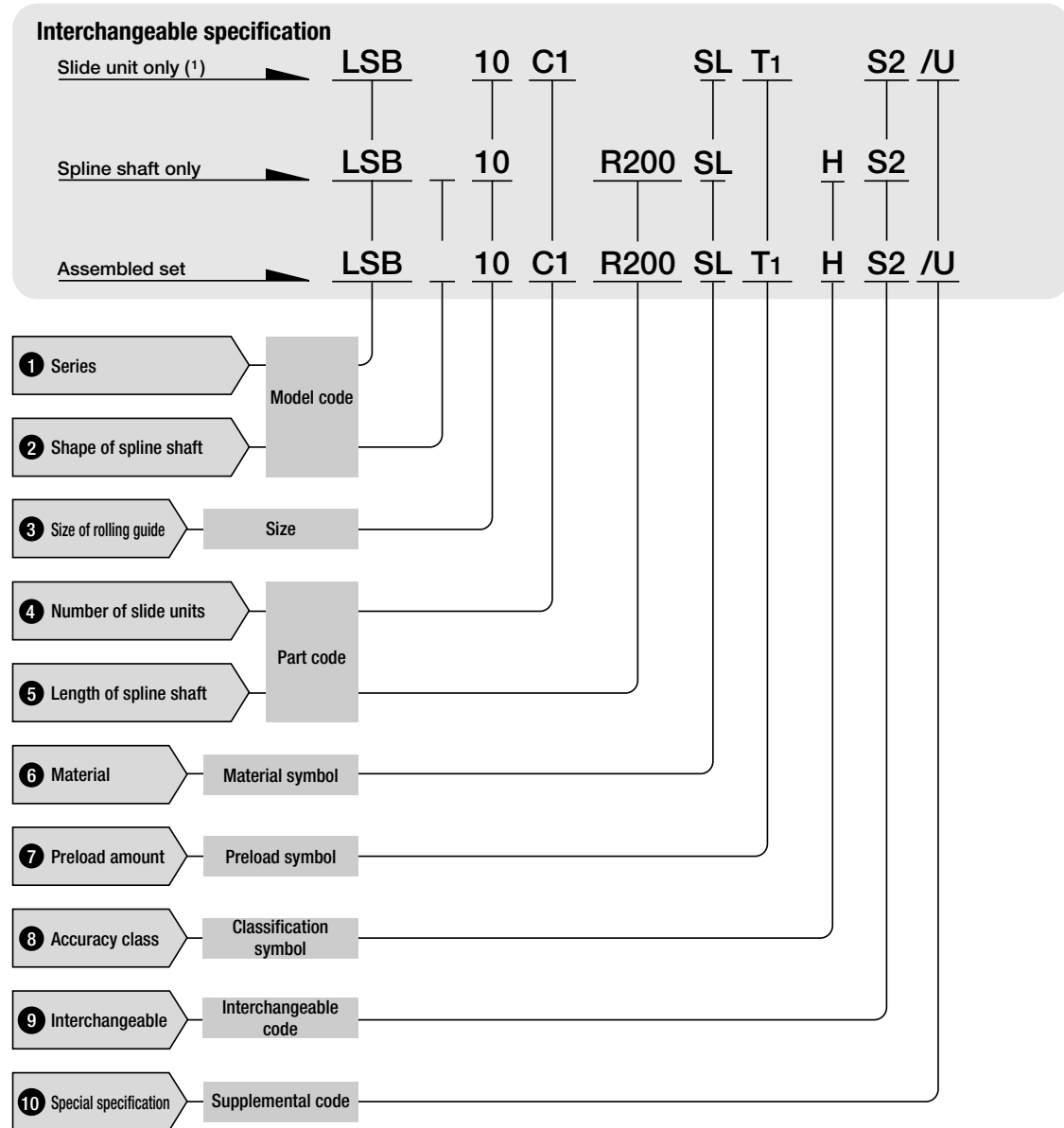

Note(1) : For the model code of a single slide unit, indicate "LSB" regardless of the spline shaft type to be combined.

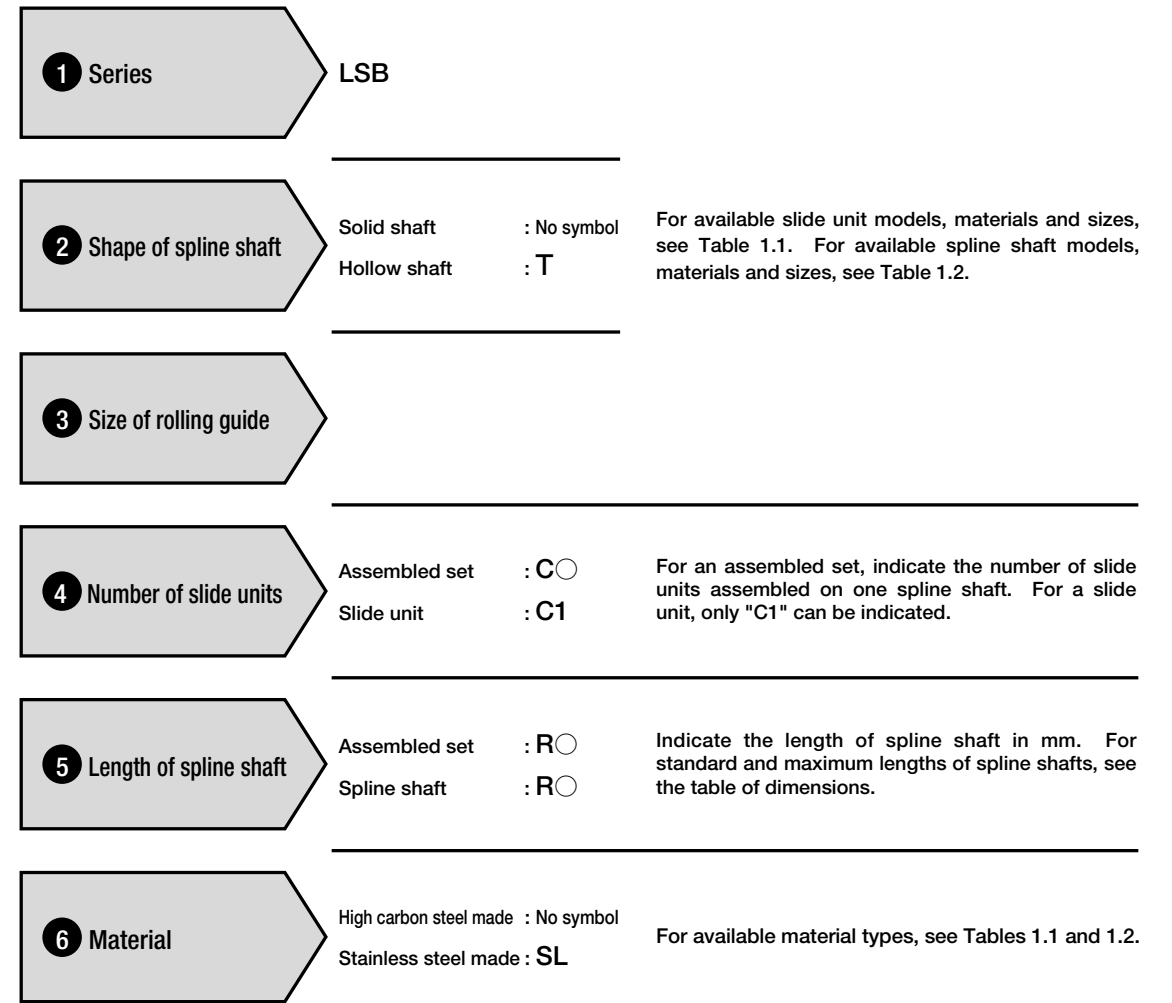

Table 1.1 Models and sizes of slide unit of Block type Linear Ball Spline

Size	Model	High carbon steel made	Stainless steel made
		LSB...C1...S1 LSB...C1...S2	LSB...C1 SL...S1 LSB...C1 SL...S2
6		—	☆
8		—	☆
10		—	☆
13		☆	—
16		☆	—
20		☆	—
25		☆	—

Remark : For the slide units of size 6, 8, and 10 models, only the stainless steel type is available. If high carbon steel type is specified in the identification number of assembled set, only the spline shaft will be high carbon steel type.

Table 1.2 Models and sizes of spline shaft of Block type Linear Ball Spline

Size	Model	High carbon steel made		Stainless steel made
		Solid shaft LSB...R...S1 LSB...R...S2	Hollow shaft LSBT...R...S1 LSBT...R...S2	Solid shaft LSB...R SL...S1 LSB...R SL...S2
6		☆	☆	☆
8		☆	☆	☆
10		☆	☆	☆
13		☆	☆	—
16		☆	☆	—
20		☆	☆	—
25		☆	☆	—

**7 Preload amount**

Standard : No symbol Specify this item for an assemble set or a single slide unit. For applicable preload types, see Table 2. For details of preload amount, see page D-15.  
 Light preload : T1

Table 2 Applicable preload types

Size	Standard (No symbol)	Light preload (T1)
6	☆	—
8	☆	☆
10	☆	☆
13	☆	☆
16	☆	☆
20	☆	☆
25	☆	☆

**8 Accuracy class**

Ordinary : No symbol Specify this item for an assemble set or a single spline shaft. For details of accuracy, see page D-11.  
 High : H

**9 Interchangeable code**

Select group 1 : S1 Assemble slide units and spline shafts with the same interchangeable code.  
 Select group 2 : S2 Performance and accuracy of "S1" group and "S2" group are the same.

**10 Special specification**

For applicable special specifications, see Table 3. For details of special specifications, see page D-16.

Table 3 Special specifications of Block type Linear Ball Spline

Special specification	Supplemental code
No end seal	N
With under seals	U

Remark 1 : Applicable to a single slide unit and an assembled set.  
 2 : "No end seal" and "With under seals" cannot be combined.

**Moment of inertia of sectional area and section modulus of spline shaft**

Moment of inertia of sectional area and section modulus of the spline shaft are shown in Table 4.

Table 4 Moment of inertia of sectional area and section modulus of spline shaft

Size	Moment of inertia of sectional area mm <sup>4</sup>		Section modulus mm <sup>3</sup>	
	Solid shaft	Hollow shaft	Solid shaft	Hollow shaft
6	55	54	19	19
8	170	170	44	43
10	440	420	90	87
13	1 220	1 160	190	180
16	2 830	2 630	360	340
20	7 110	6 620	730	680
25	17 600	15 100	1 440	1 230



## LSB • LSBT

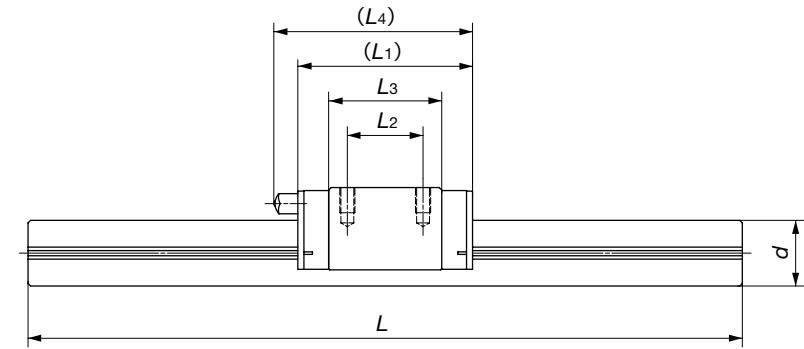
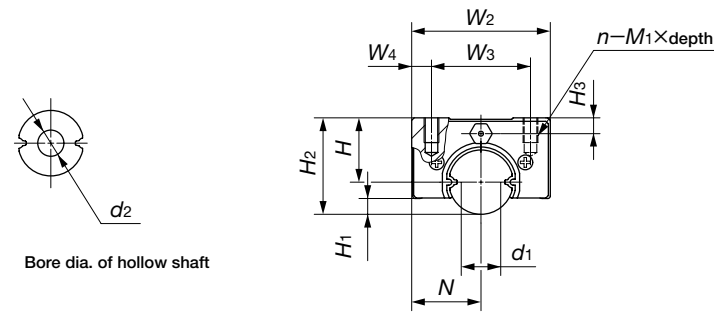

Model number	Interchangeable	Mass (Ref.) g		Dimensions of assembly mm				Dimensions of slide unit mm								
		Slide unit	Spline shaft (per 100 mm)	H	H <sub>1</sub>	H <sub>2</sub>	N	W <sub>2</sub>	W <sub>3</sub>	W <sub>4</sub>	L <sub>1</sub>	L <sub>2</sub>	L <sub>3</sub>	L <sub>4</sub>	n-M <sub>1</sub> ×depth	H <sub>3</sub>
LSB 6	☆	7.6	21.2	6	1.1	9	6.5	13	8	2.5	19	—	12.5	—	2-M2×3	1.5
LSBT 6	☆		18.8													
LSB 6...SL	☆		21.2													
LSB 8	☆	18	37.6	8	1.3	12	9	18	12	3	25	8	15.6	—	4-M3×3	1.5
LSBT 8	☆		32.1													
LSB 8...SL	☆		37.6													
LSB 10	☆	34	59.7	10	1.9	15	10.5	21	15	3	31	10	21.2	—	4-M3×4	2.5
LSBT 10	☆		49.8													
LSB 10...SL	☆		59.7													
LSB 13	☆	62	100	13	3.2	19.5	14	28	20	4	35	15	22.4	40	4-M3×5	3.2
LSBT 13	☆		77.9													
LSB 16	☆	112	152	16	4.2	24	16.5	33	25	4	43	20	28.8	48	4-M4×6	4
LSBT 16	☆		113													
LSB 20	☆	215	240	20	5.8	30	20	40	30	5	53	25	37.3	58	4-M5×10	5
LSBT 20	☆		178													
LSB 25	☆	403	376	25	6	37.5	26	52	40	6	67	30	41.8	70	4-M6×12	6
LSBT 25	☆		237													

Dimensions and tolerance of spline shaft mm						Basic dynamic load rating <sup>(4)</sup> C N	Basic static load rating <sup>(4)</sup> C <sub>0</sub> N	Dynamic torque rating <sup>(4)</sup> T N·m	Static torque rating <sup>(4)</sup> T <sub>0</sub> N·m	Static moment rating <sup>(4)</sup>	
d	Tolerance <sup>(1)</sup>	d <sub>1</sub> <sup>(2)</sup>	d <sub>2</sub>	L <sup>(3)</sup>	Maximum length					T <sub>x</sub> N·m	T <sub>y</sub> N·m
6	0 -0.012	3.7	2	150 200	300	612	1 130	1.8	3.4	2.4	2.0
										13.3	11.2
8	0 -0.015	5	3	150 200 250	500	1 200	1 960	4.8	7.8	4.9	4.1
					400					31.4	26.3
					500					3.9	6.3
						963	1 570	3.9	6.3	25.1	21.1
10	0 -0.015	6.9	4	200 300	600	1 610	2 860	8.1	14.3	9.4	7.9
										55.0	46.2
13	0 -0.018	9	6	200 300 400	800	2 960	4 450	19.2	28.9	16.0	13.4
										99.9	83.8
16	0 -0.018	11.4	8	200 300 400	1 000	4 390	6 730	35.1	53.9	30.8	25.9
										183	153
20	0 -0.021	15	10	300 400 500 600	1 000	5 830	9 420	58.3	94.2	54.6	45.8
										310	260
25	0 -0.021	19.3	15	300 400 500 600 800	1 200	9 360	13 900	122	181	99.2	99.2
										587	587

Note(1) : Not applicable to the hollow shaft (LSBT).

(2) : Dimension d<sub>1</sub> indicates the maximum diameter when machining is done at the shaft ends.

(3) : This length is the standard length. Spline shafts in other length are also available. Simply indicate the necessary length of spline shaft in mm in the identification number.

(4) : The directions of basic dynamic load rating (C), basic static load rating (C<sub>0</sub>), dynamic torque rating (T) and static torque/moment rating (T<sub>0</sub>, T<sub>x</sub>, T<sub>y</sub>) are shown in the sketches below.

The upper values in the T<sub>x</sub> and T<sub>y</sub> columns apply to one slide unit, and the lower values apply to two slide units in close contact.

Remark 1 : All Block type Linear Ball Splines are interchangeable specification products.

2 : Models LSB6, LSBT6, LSB6...SL, LSB8, LSBT8, LSB8...SL, LSB10, LSBT10 and LSB10...SL are provided with an oil hole.

For grease nipple and oil hole specifications, see page D-19.

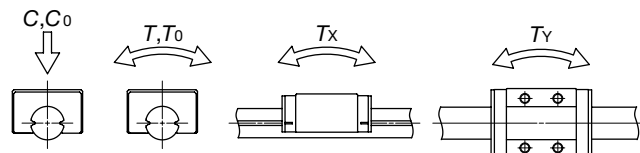

Example of identification number of assembled set (For details, see "Identification number and specification".)

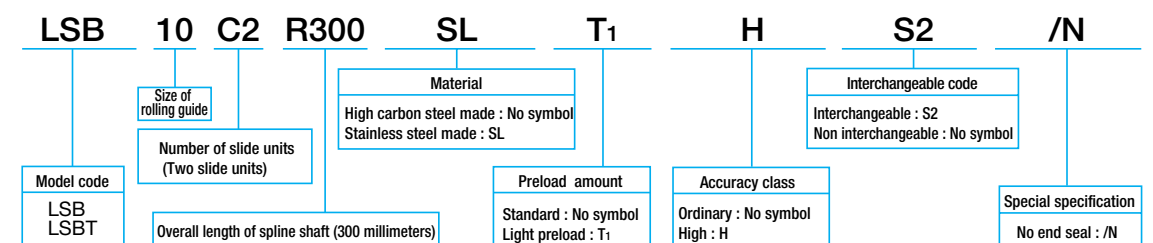

# Structure of Stroke Ball Spline

## LS

**IICO** Stroke Ball Spline LS is limited stroke type linear ball spline. Large diameter steel balls are arranged in two rows and in four point contact with the raceways, achieving compact design with high rigidity under any direction of load and moment.

### Unprecedented smoothness

Precise ball retainer is incorporated and non-circulation structure provide superior low friction even in the vertical operation.

### Compact design with high rigidity

Large diameter steel balls are arranged in two rows and in four point contact with the raceways, achieving compact design with high rigidity under any direction of load and moment.

### Superior positioning accuracy

By applying suitable preload, clearance in the rotational direction is eliminated. So high positioning accuracy in the rotational direction has been obtained.

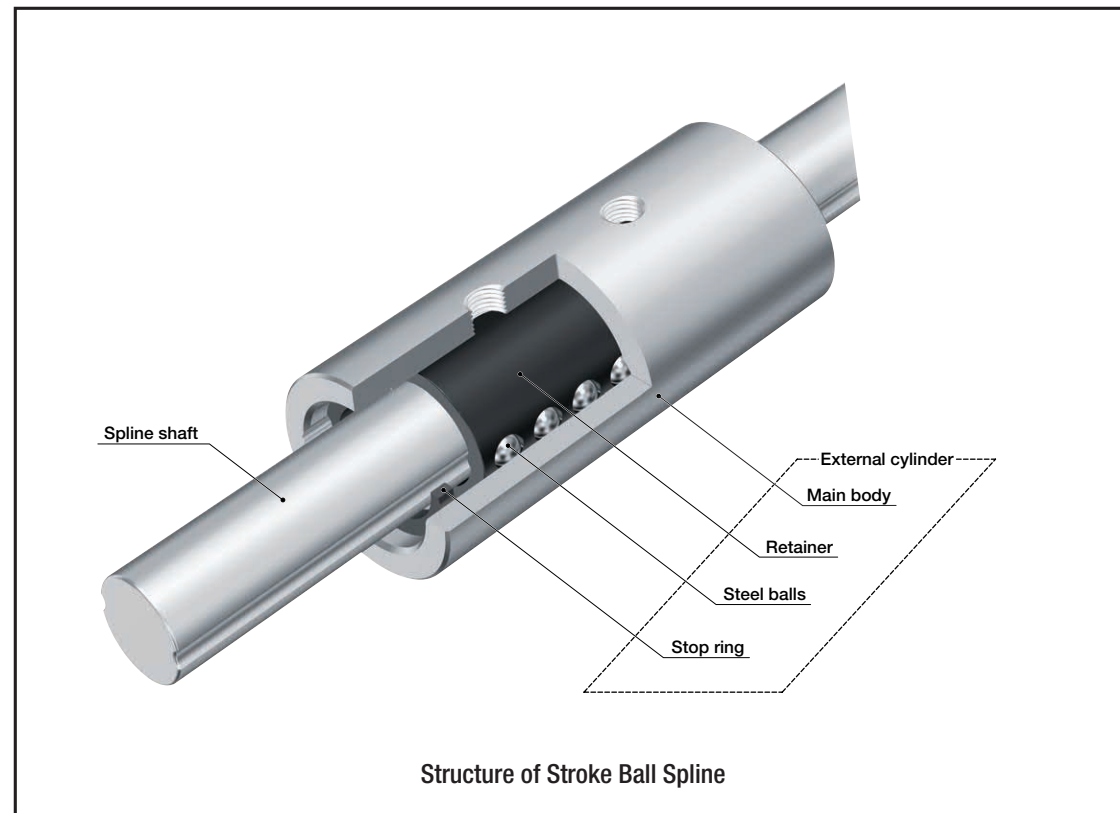

## Stroke Ball Spline LS series

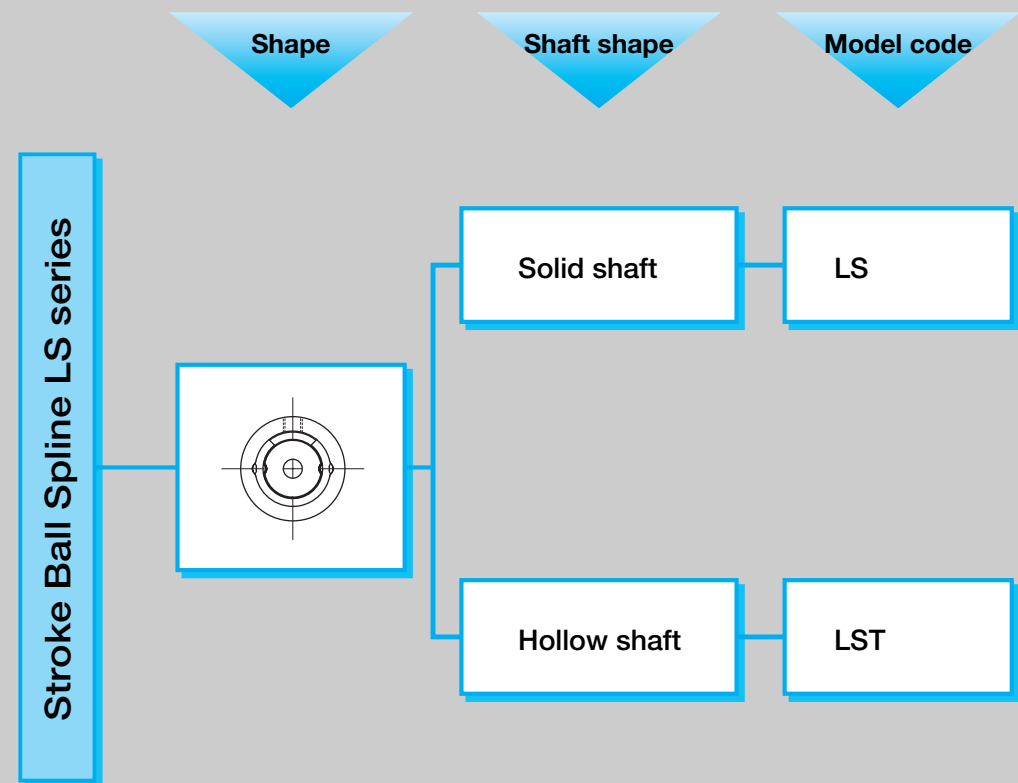

## Identification Number

Identification numbers of IICO Stroke Ball Spline LS series consist of a model code, a size, a part code, a preload symbol, a classification symbol, and supplemental codes.

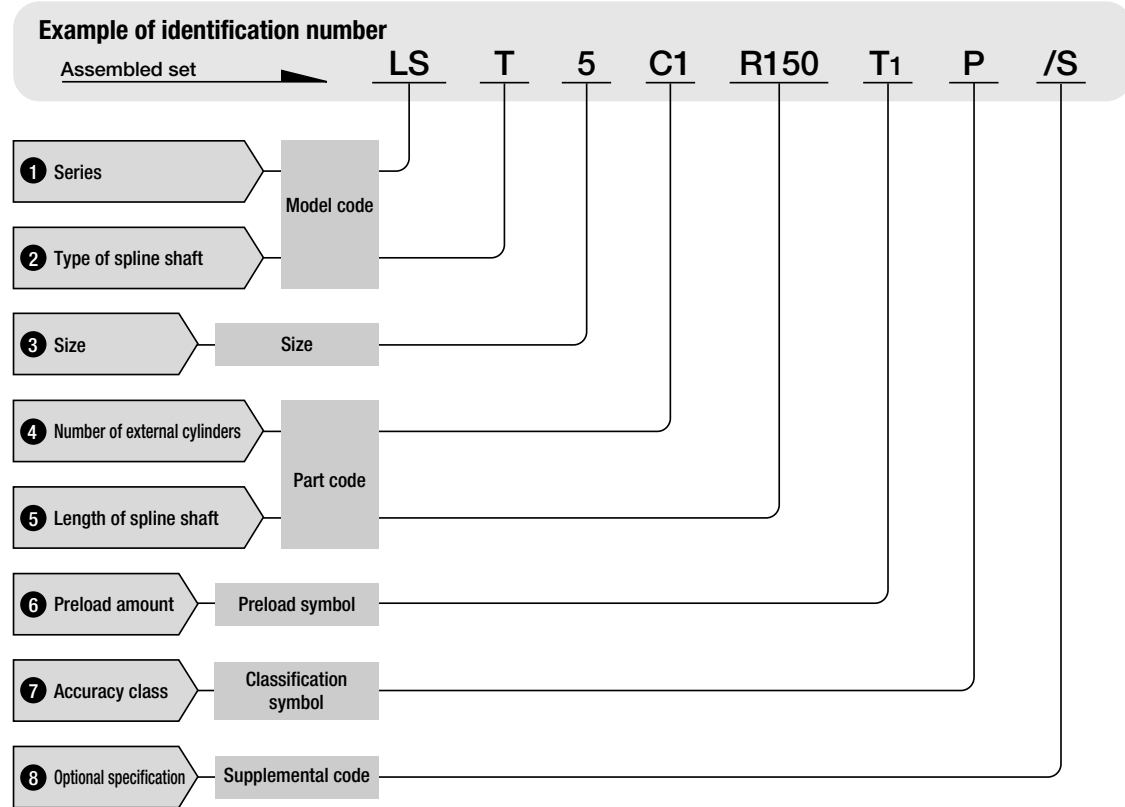

**1 Series** Stroke Ball Spline LS

**2 Type of spline shaft**  
 Solid shaft : No symbol  
 Hollow shaft : T

**3 Size** 4, 5, 6

Table 1 Models and sizes of Stroke Ball Spline

Size	Type	Solid shaft	Hollow shaft
		LS	LST
4		○	○
5		○	○
6		○	○

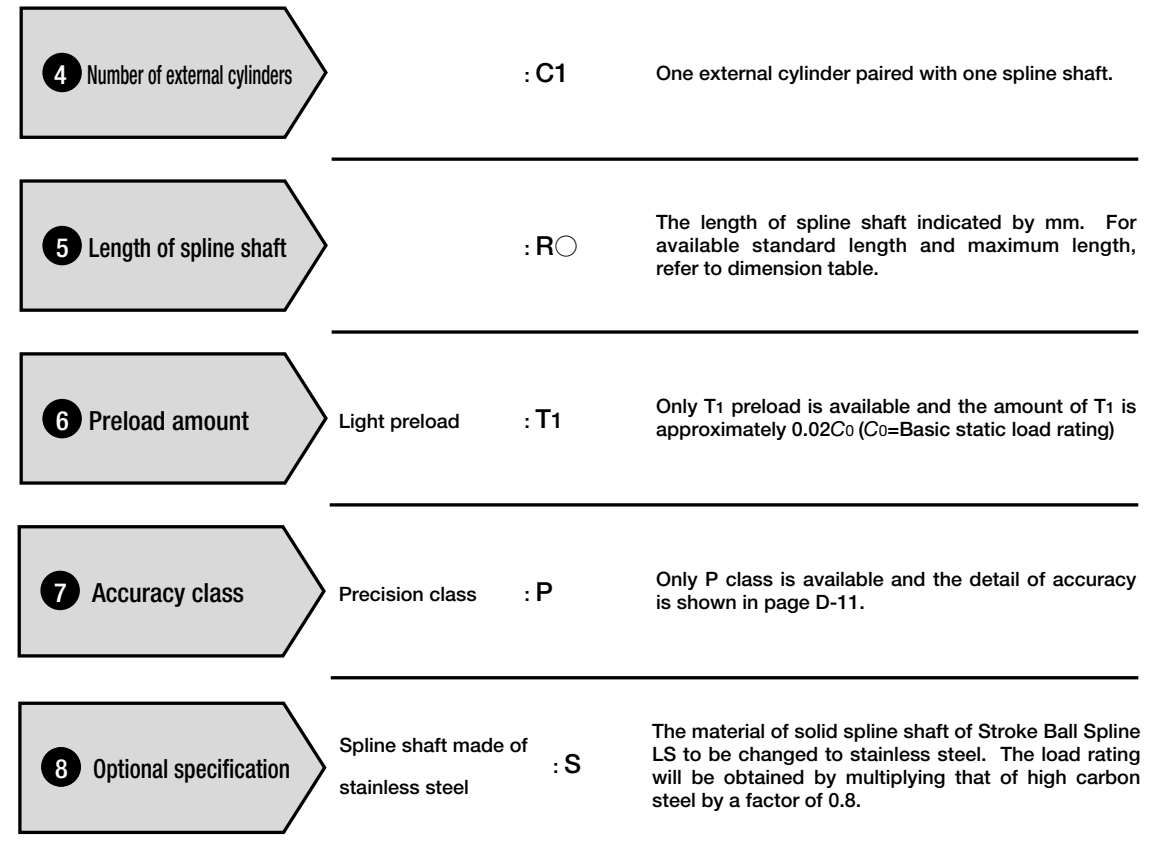

Table 2 Special specifications

Special specifications	Supplemental code	Assembled set
Spline shaft in stainless steel	S	○(1)

Note(1) : Applicable to size 5, 6 hollow shaft.

## Spline Shaft

Moment of inertia of sectional area and section modulus of the spline shaft are shown in Table 3.

Table 3 Moment of inertia of sectional area and section modulus

Model number	Moment of inertia of sectional area mm <sup>4</sup>		Section modulus mm <sup>3</sup>	
	Solid shaft	Hollow shaft	Solid shaft	Hollow shaft
LS 4	12	12	6	6
LS 5	29	29	12	12
LS 6	61	61	21	21

LS • LST

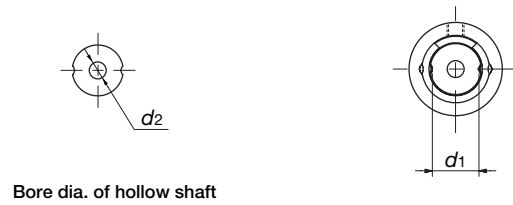

Bore dia. of hollow shaft

Model number	Mass (Ref.) g		Dimension and tolerance of external cylinder mm						Dimension and tolerance of spline shaft mm			
	External cylinder	Spline shaft (per 100 mm)	D	Tolerance	L <sub>1</sub>	L <sub>2</sub>	M	Maximum depth of thread	d	Tolerance	d <sub>1</sub> <sup>(1)</sup>	d <sub>2</sub>
LS 4	5.7	9.6	8	0 -0.009	24	10	M2	1.3	4	0 -0.012	3.2	-
LST 4		8.6										1.5
LS 5	8.9	14.9	10	0 -0.009	27	12	M2	1.4	5	0 -0.012	4.2	-
LST 5		12.4										2
LS 6	10.9	19	11	0 -0.011	29	15	M2	1.4	6	0 -0.012	5.2	-
LST 6		16.5										2

Note<sup>(1)</sup>: Dimension  $d_1$  indicates the maximum diameter when machining is done at the spline shaft ends.  
<sup>(2)</sup>: Lengths indicated are standard lengths. Spline shafts in different lengths are also available. Simply indicate the necessary length of spline shaft (mm) in the identification number.  
<sup>(3)</sup>: The directions of dynamic load rating (C), basic static load rating (C<sub>0</sub>), dynamic torque rating (T) and static torque/moment rating (T<sub>0</sub>, T<sub>x</sub>, and T<sub>y</sub>) are shown in the sketches below.  
 Remark: Grease is not pre-packed. Initial lubrication with grease or oil is necessary before the operation.

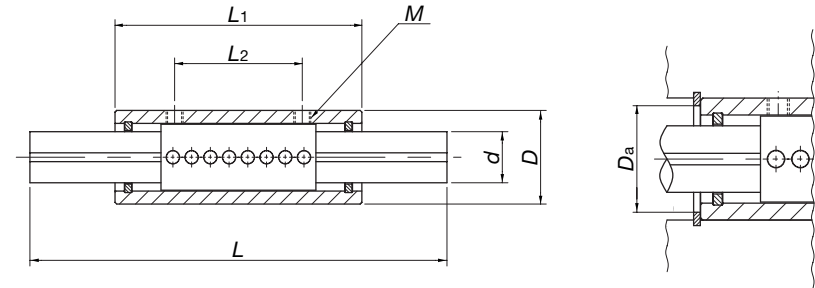
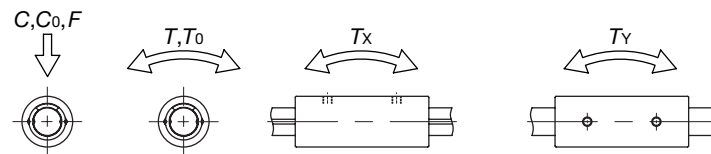

L <sup>(2)</sup>	Maximum length	Effective stroke length mm	Maximum stroke length mm	Mounting dimension D <sub>a</sub> mm	Basic dynamic load rating <sup>(3)</sup> C N	Basic static load rating <sup>(3)</sup> C <sub>0</sub> N	Allowable load <sup>(3)</sup> F N	Dynamic torque rating <sup>(3)</sup> T N·m	Static torque rating <sup>(3)</sup> T <sub>0</sub> N·m	Static moment rating <sup>(3)</sup>	
										T <sub>x</sub> N·m	T <sub>y</sub> N·m
100 150	200	10	13.2	5	285	380	127	0.66	0.87	0.88	1.5
	150										
100 150	200	10	14	7	616	748	249	1.8	2.2	2.0	3.5
	150 200										

Example of identification number of assembled set (For details, see "Identification number and specification".)

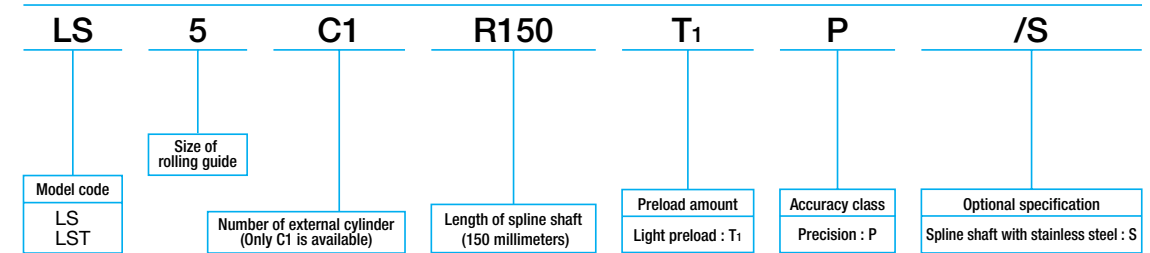



# Crossed Roller Ways

Description of each series and Table of dimensions

E

## Anti-Creep Cage Crossed Roller Way

Page E-2 to E-17



## Anti-Creep Cage Crossed Roller Way Unit

Page E-18 to E-25



## Crossed Roller Way

Page E-26 to E-71

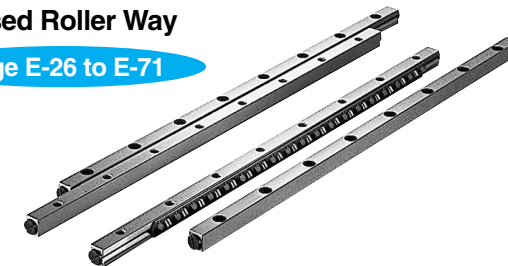

## Crossed Roller Way Unit

Page E-72 to E-89



In the table of dimensions, standard products are referred to using identification numbers marked with  . The identification numbers marked with   refer to our semi-standard products.

# Anti-Creep Cage Crossed Roller Way

## CRWG

**IKO** Anti-Creep Cage Crossed Roller Way is the product with a cage creep proof function using a rack and pinion mechanism originated from **IKO** Crossed Roller Way, featuring smooth linear motion with super high accuracy.

### Reliable running performance

Perfect solution for cage creeping problems by a built in rack and pinion mechanism as an **IKO** original design.

### Freedom in mounting

This series is reliable for applications such as a vertical axis for which the existing Crossed Roller Way is not easy to use.

### Applicable to high-speed operation

Any corrective operation for cage creeping is not necessary even for a long-time operation.

### Interchangeable in dimensions

It has full interchangeability with the existing Crossed Roller Way in mounting dimension. Since the series has the same external dimensions to those of the existing Crossed Roller Way and can be easily replaced without any modification on the machine or equipment using the existing Crossed Roller Way.

### Energy-saving in operation

Any corrective operation for cage creeping is not necessary even for a long-time operation.

### Smooth operation

Precisely finished raceways are combined with roller cages, in which the length of super precise roller is accurately controlled to avoid skewing. Very smooth linear motion with very little frictional resistance and free from stick-slip can be achieved.

### Easy mounting

The mounting holes of the ways are female thread holes with a counter bore. So the mounting method is flexible, allowing the ways to be mounted either by inserted through the holes prepared on machines. Mounting structure can be designed freely.

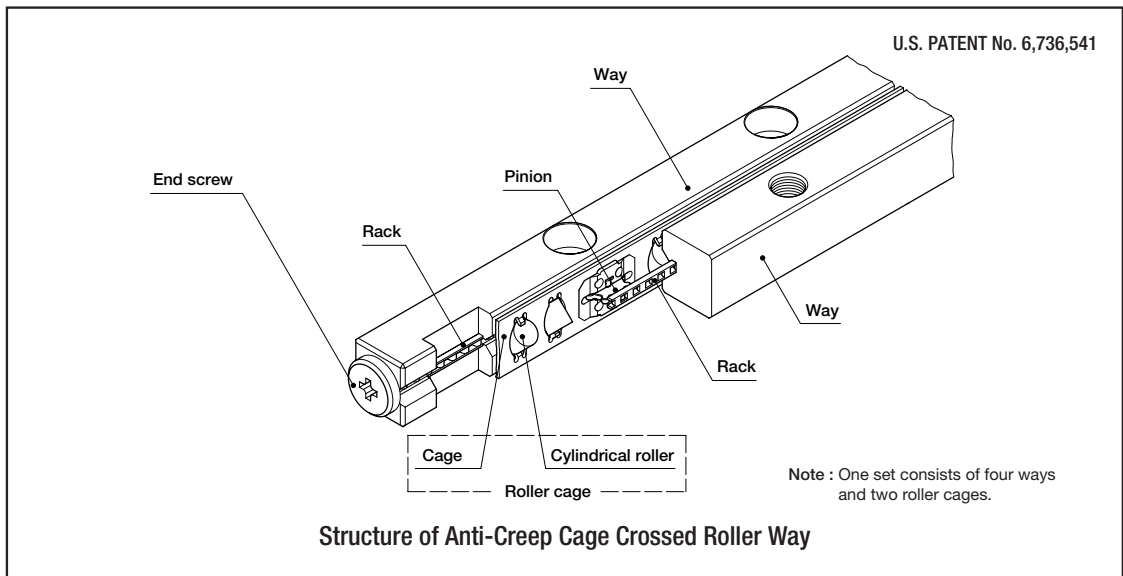

## Anti-Creep Cage Crossed Roller Way series

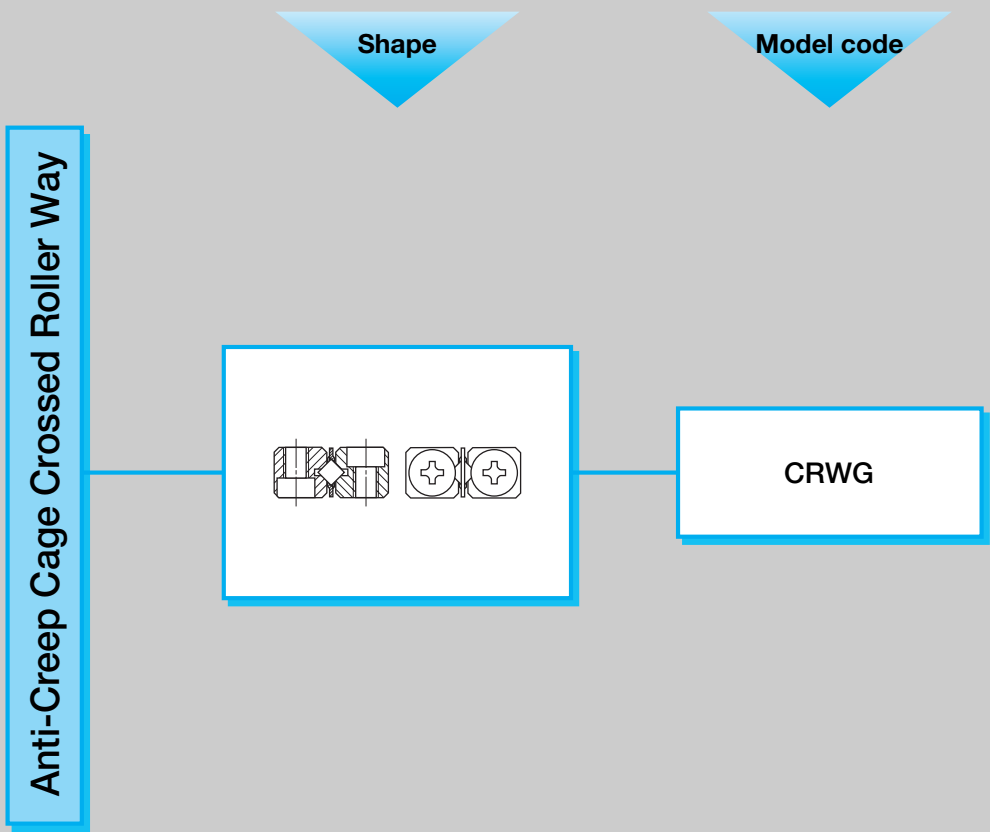

## Identification number and specification

The specification of Anti-Creep Cage Crossed Roller Way is indicated by the identification number. Indicate each specification by using a model code, size, part code, classification symbol, and supplemental codes. The ordering unit is a set of the combination of four ways and two roller cages.

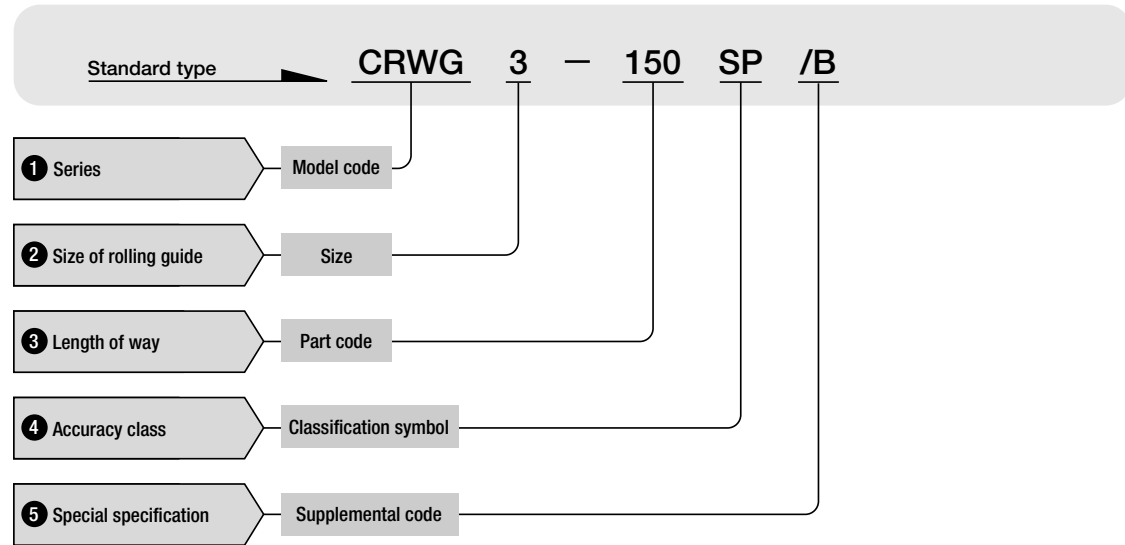

### 1 Series

Standard type : CRWG

### 2 Size

Applicable type and size are shown in Table 1.

Table 1 Type and size

Size	Type	Carbon steel
2		○
3		○
4		○
6		○

### 3 Length of way

The length of way is indicated in millimeters. For applicable way lengths, please refer Table1.

Table 1 Length of way

Model number	Length of way mm								
	CRWG 2	30	45	60	75	90	105	120	135
CRWG 3	50	75	100	125	150	175	200	225	250
CRWG 4	80	120	160	200	240	280	320	—	—
CRWG 6	100	150	200	250	300	350	—	—	—

### 4 Accuracy class

Standard : No symbol  
 Super precision : SP  
 For the allowable values of parallelism of the raceway to the reference mounting surface, see Fig.1.

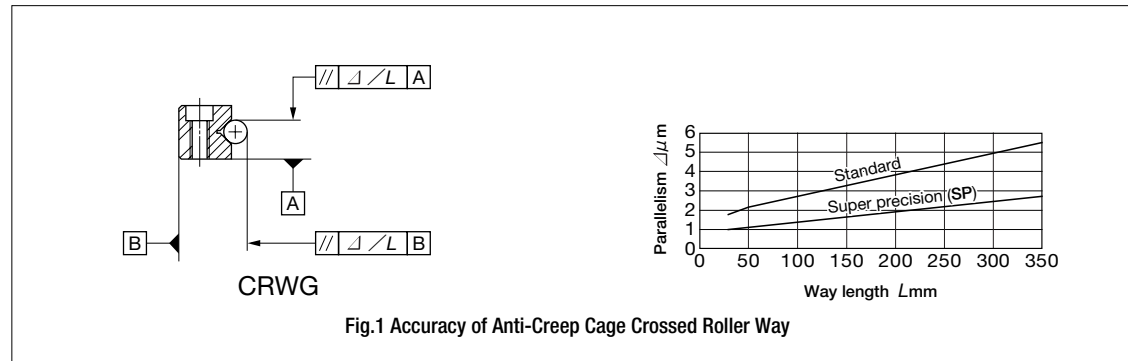



5 Special specification

Detail of special specification of Crossed Roller Way is shown below. Indicate any specification by adding the supplemental code to the end of the identification number.

Special mounting screw /B

The way on the preload adjustment side is moved when the preload is adjusted. There should be some allowance for movement between the way fixing screw and the mounting hole. When such allowance cannot be provided or when the fixing screw is installed from the way side as shown in Fig. 2, it is convenient to use the attached special mounting screws.

This special mounting screw is also available when the positional accuracy of the mounting holes and female thread of the machine on which the fixed side ways are mounted is not sufficient.

Table 2 Dimensions of special mounting screws

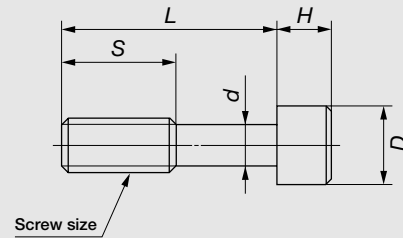

unit : mm

Size of CRWG	Screw size	d	D	H	L	S
3	M 3	2.3	5	3	12	5
4	M 4	3.1	6	4	15	6
6	M 5	3.9	8	5	20	8

Remark : Not applicable to size2

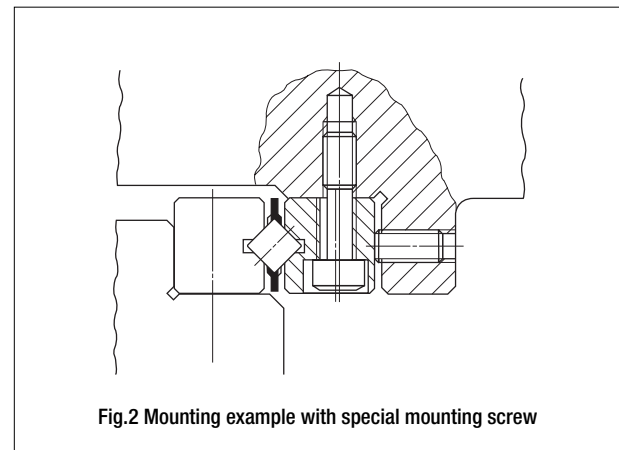

Load Rating and Allowable Load

For the load rating and allowable load of Anti-Creep Cage Crossed Roller Way, values for a downward load provided when a combination of four ways and two roller cages is used in parallel are indicated. An outline of them is described below.

The load ratings and allowable load of Anti-Creep Cage Crossed Roller Way are designed for equal load capacity in downward, upward, and lateral directions.

Basic dynamic load rating C

The basic dynamic load rating is defined as a constant load both in direction and magnitude under which a group of identical Crossed Roller Way are individually operated and 90% of those in the group can travel 100 x 10<sup>3</sup> meters free from material damage due to rolling contact fatigue.

Basic static load rating C<sub>0</sub>

The basic static load rating is defined as the static load that gives a prescribed constant contact stress at the center of the contact area between a rolling element and raceways receiving the maximum load.

Allowable load F

The allowable load is a load under which the sum of elastic deformations of the rolling element and the raceways in the contact area subjected to the maximum contact stress is small enough to guarantee accuracy and smooth rolling movement.

Therefore, where very smooth and highly accurate linear motion is required, make sure to use an Anti-Creep Cage Crossed Roller Way well within the allowable load values.

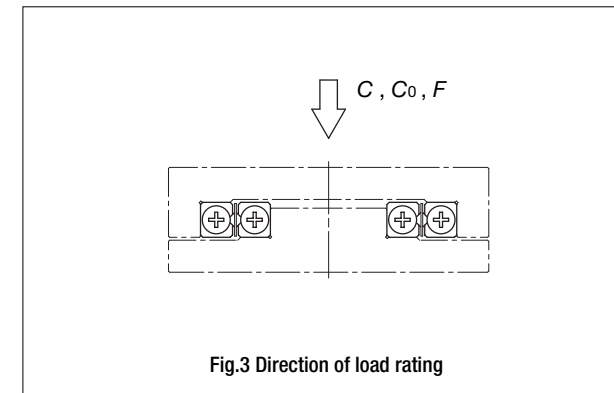

## Lubrication and dust protection

Oil or grease is used as a lubricant for Anti-Creep Cage Crossed Roller Way. Oil is generally used for high speed or low friction operation. On the other hand, grease is used when operating speed is low. In case of grease lubrication, good quality lithium-soap base grease is recommended. When operation speed is low and load is light, coat the raceways with grease before use and rubricate periodically. Structure show in Fig.4 makes the lubrication easy.

Anti-Creep Cage Crossed Roller Way is finished in production very accurately. If harmful foreign materials such as dust or chips enter inside the ways, this will shorten the life or lower the accuracy. With the object of preventing external harmful foreign materials such as dust, chips and water from entering inside, it is recommended to install a non-contact-type labyrinth seal shown in Fig. 5 or a contact type wiper seal shown in Fig. 6 on both side faces.

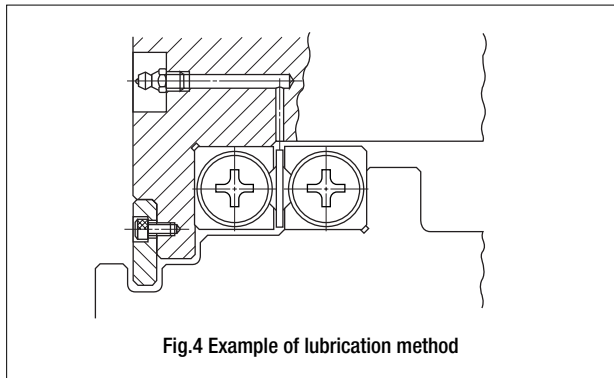

Fig.4 Example of lubrication method

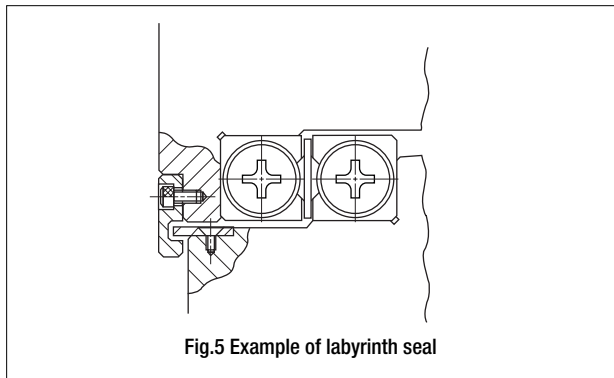

Fig.5 Example of labyrinth seal

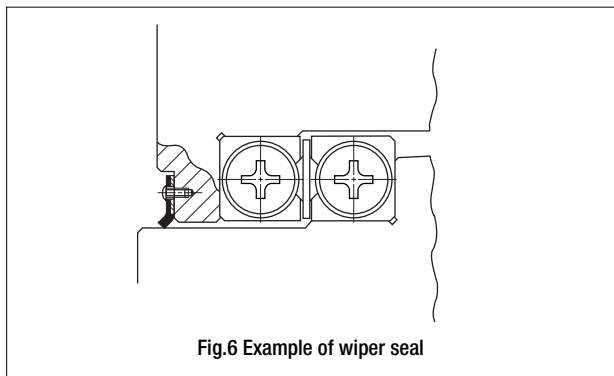

Fig.6 Example of wiper seal

## Precautions for use

### 1 Specifications of Anti-Creep Cage Crossed Roller Way

Check whether the operating characteristics of the selected Anti-Creep Cage Crossed Roller Way are suitable for the application of the machine or equipment.

### 2 Handling of Anti-Creep Cage Crossed Roller Way

Anti-Creep Cage Crossed Roller Ways are finished in production very accurately, so handle carefully. A pinion is assembled in the roller cage. If the cage is dropped or handled roughly, the pinion may come off. As cutting off the cage may cause the pinion coming off or damage to the pinion mounting part, so please avoid cutting off the cage.

A rack is assembled in the way and fixed its position with the end screws. When assembling, the rack may come out from the way by removing the end screws.

### 3 Accuracy of the mounting part

The general configuration of mating mounting surfaces for Anti-Creep Cage Crossed Roller Way is shown Fig. 7.

Accuracy of the mating mounting surfaces are, in general, as shown in Table 3. The accuracy of the mating mounting surfaces directly affects the operating accuracy and performance of Anti-Creep Cage Crossed Roller Way. If very precise operating accuracy is required, higher accuracy of mating mounting surfaces than the values shown in Table 3 may be needed.

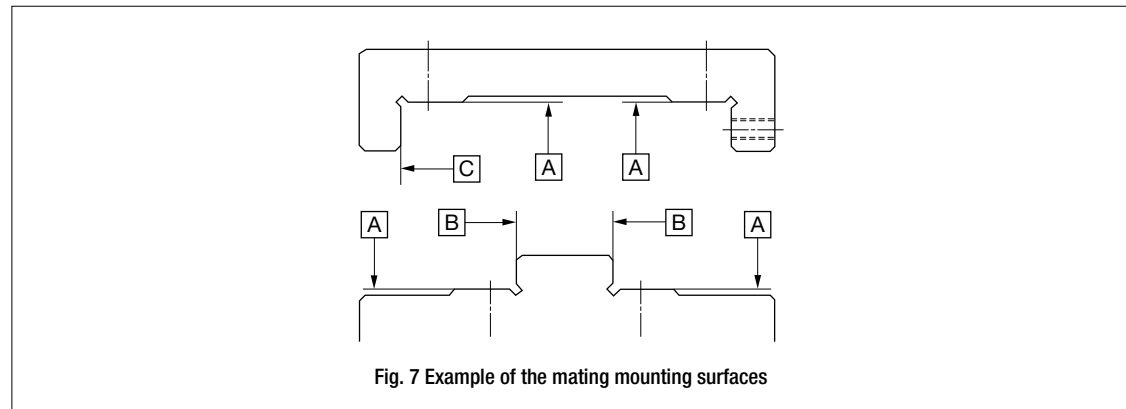

Fig. 7 Example of the mating mounting surfaces

Table 3 Accuracy of mating mounting surfaces

<p><b>A</b> surface</p>	<ul style="list-style-type: none"> <li>This accuracy directly affects the operating accuracy.</li> <li>Flatness of <b>A</b> surface (four places) should be equal or nearly equal to the value of parallelism in Fig. 1 on page E-5.</li> </ul>
<p><b>B</b> and <b>C</b> surfaces</p>	<ul style="list-style-type: none"> <li>Flatness</li> <li>Flatness of these surfaces directly affects preload.</li> <li>The value of flatness should be equal or nearly equal to the value of parallelism in Fig. 1 on page E-51.</li> <li>Squareness</li> <li>Squareness to <b>A</b> surface affects the rigidity of assembled unit in the preload direction.</li> <li>Consequently, a high accuracy finish is necessary.</li> </ul>

#### 4 Shape of the mounting part

It is recommended to make a relieved fillet at the corner of the mating mounting surfaces as shown in Fig.8. Allow a clearance of 0.5 mm or more between the way and the mating material of the other side.

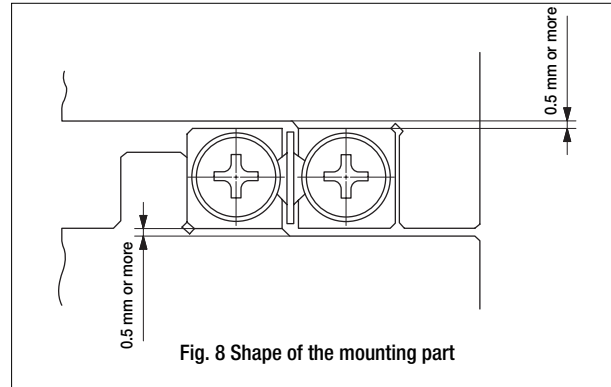

Fig. 8 Shape of the mounting part

#### 5 Preload method

Preload adjusting screws are generally used for setting preload, as shown in Fig.9. The size of the preload adjusting screws are the same as that of the mounting screws for the ways. The position of the preload adjusting screws is at the same position as the mounting screws of the ways. For centering, use half of way height H.

Preload amounts differ according to the application of machine or equipment. Excessive preloads deteriorate life and often damage the raceways. Therefore, zero or minimal preload is recommended in general. If accuracy and rigidity are important, a setting plate as shown in Fig.10.1 or a tapered jib as shown in Fig.10.2 may be used.

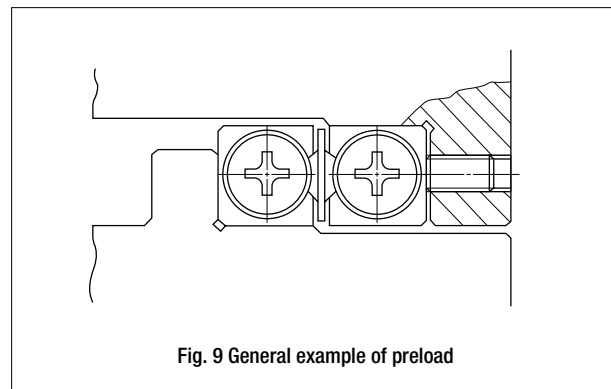

Fig. 9 General example of preload

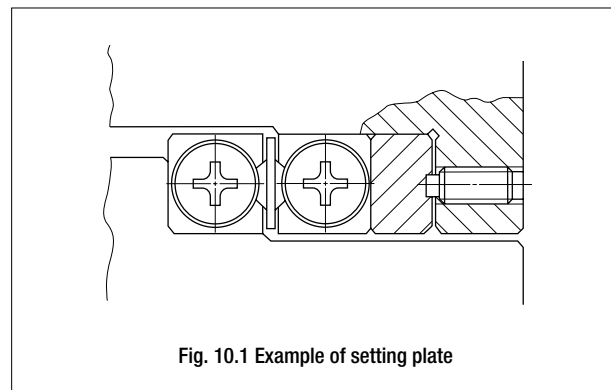

Fig. 10.1 Example of setting plate

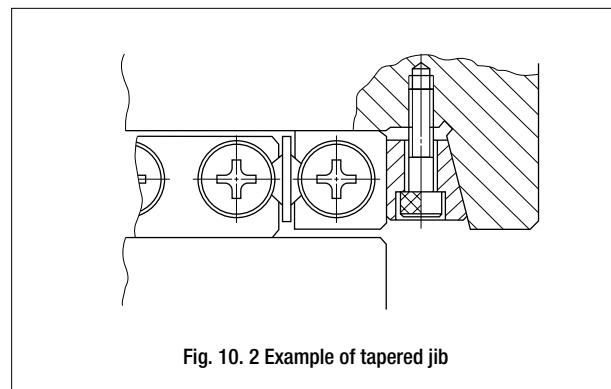

Fig. 10.2 Example of tapered jib

#### 6 Maximum operating temperature

Anti-Creep Cage Crossed Roller Way contains synthetic resin parts. Accordingly, the maximum operating temperature is 120°C. In case of continuous operation, operating temperature should not exceed 100°C.

#### 7 Maximum speed

The operating speed of Anti-Creep Cage Crossed Roller Way should not exceed 30m/min.

#### 8 Tightening torque of mounting screws

Tightening torque of mounting screws is shown in Table 4. If vibration or shock is large, or moment load is applied, it is recommended to tighten the screws to about 1.3 times the values shown in Table 5. If vibration and shock are not present and high operating accuracy is needed, a lower tightening torque than the values shown in Table 4 is suggested. In this case, adhesive or lock-screws may be used to prevent any subsequent loosening of the mounting screws.

Table 4 Tightening torque of screws

Screw size	Tightening torque
	N·m
M2×0.4	0.23
M3×0.5	1.4
M4×0.7	3.2
M5×0.8	6.3
M6×1	10.7

Remark : If the screw sizes on table side and bed side are different, use the tightening torque of the smaller screw size for both screws.

# Mounting

A general method of Anti-Cage Creep Crossed Roller Way is shown in Fig.11. The general procedure is as follows.

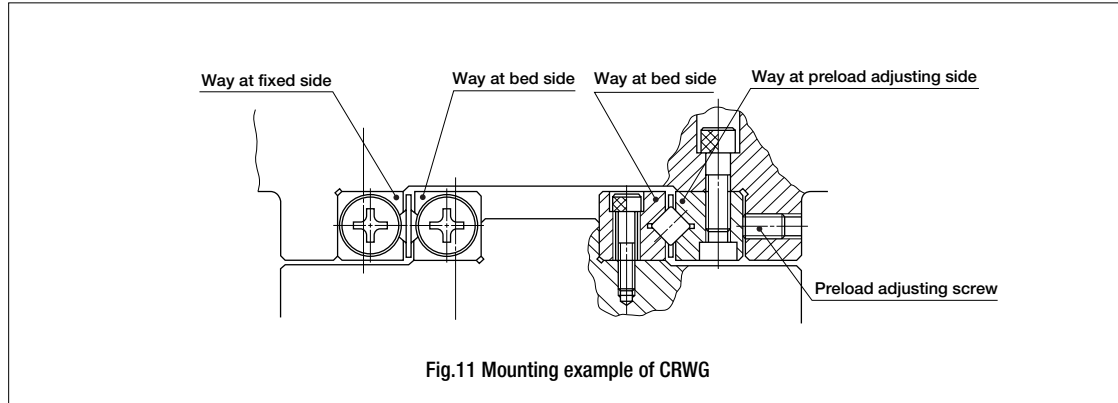

Fig.11 Mounting example of CRWG

## 1 Preparation for mounting

- CRWG is delivered as an individual package containing four ways and two roller cages. The ways in each package are not interchangeable with ways in other packages, so do not mix them.
- Separate the end screws or end stoppers and wash the ways with a clean cleaning agent. After cleaning, apply rust preventing oil or lubricating oil.

## 2 Cleaning of mounting surfaces of table and bed

- Remove burrs and blemishes from mounting surfaces of table and bed with an oil-stone, etc. During this process, also pay attention to the corner grooves of the mounting surfaces.
- Wipe off dust with clean cloth and apply rust preventive oil or lubricating oil.

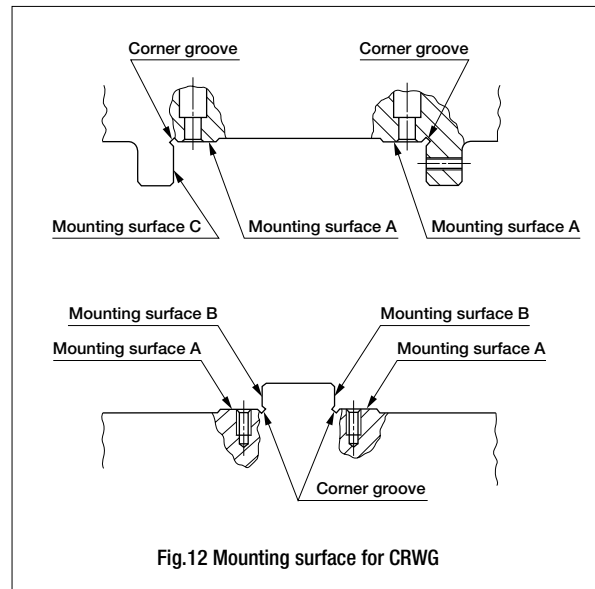

Fig.12 Mounting surface for CRWG

## 3 Mounting of ways at bed side (Fig.13)

- After fitting mounting surface of ways onto the mating mounting surfaces of bed, temporarily tighten the mounting screws with uniform tightening torque.
- After closely fitting the ways to B surfaces (See Fig.12), tighten mounting screws uniformly to the prescribed tightening torque.
- If high accuracy is required, tighten the mounting screws uniformly to the prescribed tightening torque while checking the parallelism of the two ways along the overall way length.
- General tightening torque of mounting screws is shown in Table 4 on page E-57.

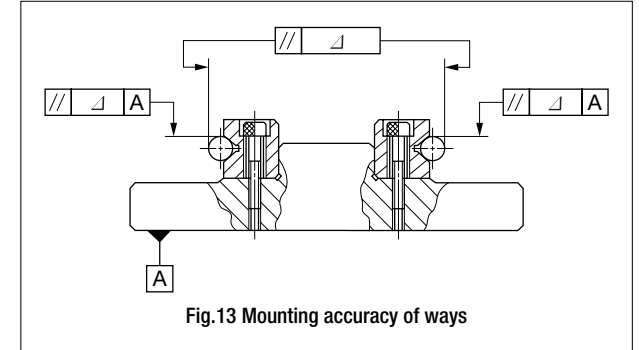

Fig.13 Mounting accuracy of ways

## 4 Mounting of ways at table side (Fig.14)

- After fitting the mounting surfaces of the way at the fixed side to the mating mounting surfaces of table, temporarily tighten the mounting screws at the fixed side with uniform tightening torque.
- After closely fitting the way at the fixed side to C surface, tighten the mounting screws at the fixed side uniformly to the prescribed tightening torque.
- Loosen the preload adjusting screws and temporarily tighten the mounting screws of the way at adjusting side with uniform and light tightening torque.

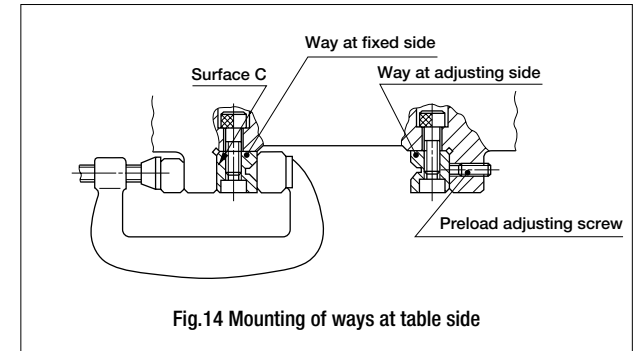

Fig.14 Mounting of ways at table side

## 5 Assembling of table and bed

- Remove end screws from the way at table side and way at the bed-side in the side to which the cylindrical rollers with a retainer are inserted. (See Fig.15.1)

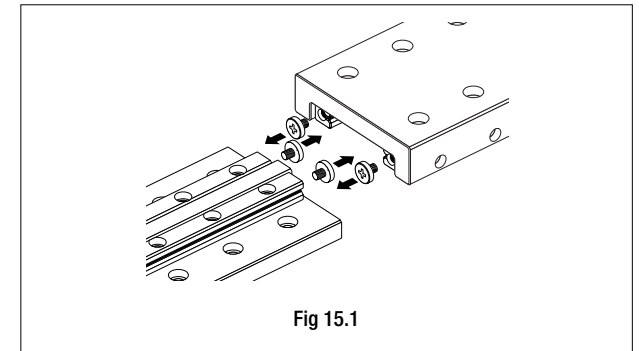

Fig 15.1

- Place the cylindrical rollers with a retainer on the way at bed-side with the center of the pinion gear in the center of the retainer engaged with the end of the rack gear of the way. (See Fig.15.2) Do not bend the retainer.

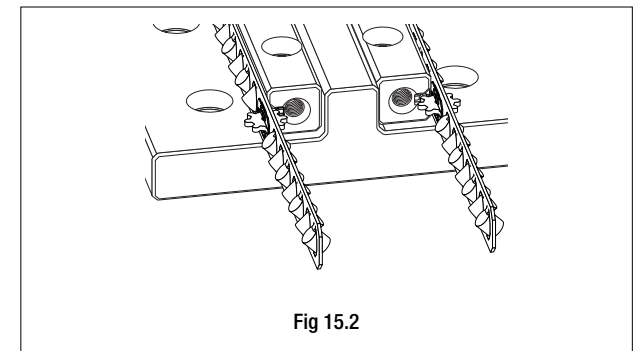

Fig 15.2

- Engage the end of the rack gear of the way at table side with the pinion gear while adjusting the longitudinal and traverse positions of the way at table-side and pushing the retainer to secure. Do not give any excessive force to the cage. (See Fig.15.3)

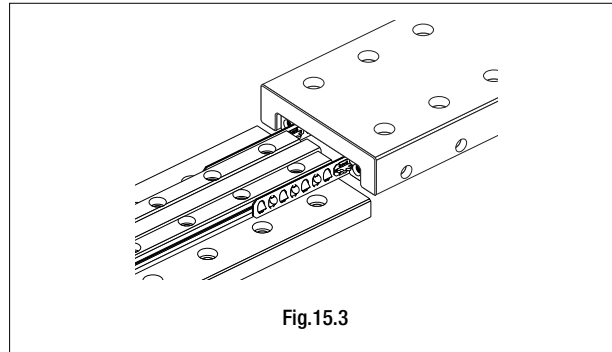

Fig.15.3

- Slide the table on the base. Do not apply any offset load to the rack gear and the pinion gear and do not deform the cage. Check and make sure the rack gear is over the end of the way. If the rack gear is over the end of the way, gently push the rack gear into the way while moving the table at a little stroke. (See Fig.15.4)

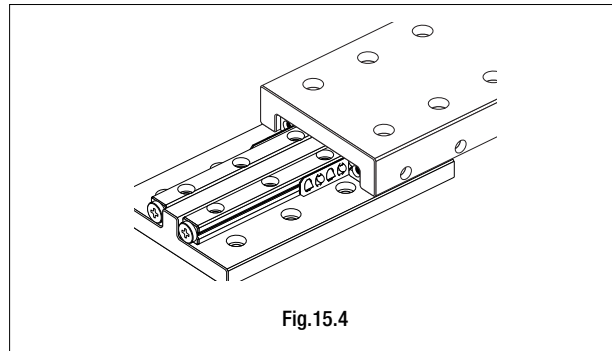

Fig.15.4

- Slide the table to the center of the stroke and tighten the end screws. (See Fig.15.5)

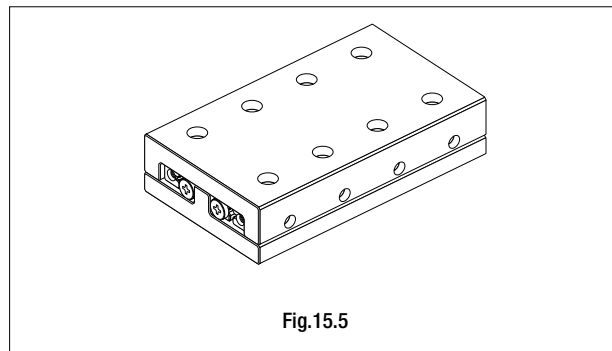

Fig.15.5

- Gently move the table at a full stroke and make sure that the cylindrical roller at each end of the retainer does not hit the end screw of the track base within the stroke. If the roller hits the retainer end, repeat the above steps from the first. (See Fig.15.6)

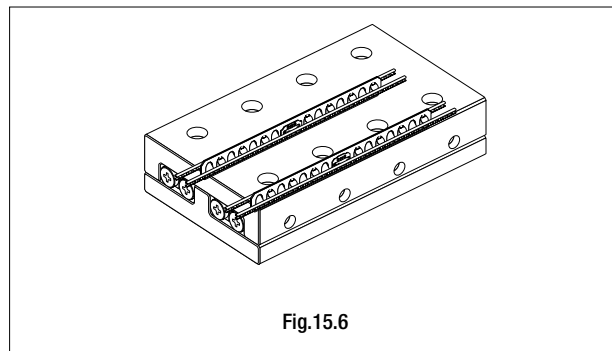

Fig.15.6

After checking the stroke movement, adjust the preload, check the slide movement of the table and check the accuracy. With this, the mounting procedure of the CRWG crossed roller way is completed.

### 6 Preload adjustment

- Preload adjustment is done only when mounting screws for the way at the adjusting side are temporarily tightened.
- Preload adjustment is started from the adjusting screw at the center of the way length, proceeding alternately to the left and right.
- While checking the clearance (deflection) at the side surface of table, tighten each amount, then repeat the same process applying a higher tightening torque until a dial gauge indicates zero-clearance. (No more change in deflection) Record the tightening torque of the adjusting screws at zero-clearance.
- When adjusting the screws close to the end of the way, gradually stroke the table and ensure that the roller cage is positioned at the adjusting screws.
- Using the above process, the internal clearance becomes zero or minimal amount of preload, but the preload amount is not uniform along the way length. Therefore, repeat the same process and tighten all adjusting screws uniformly to the recorded tightening torque.

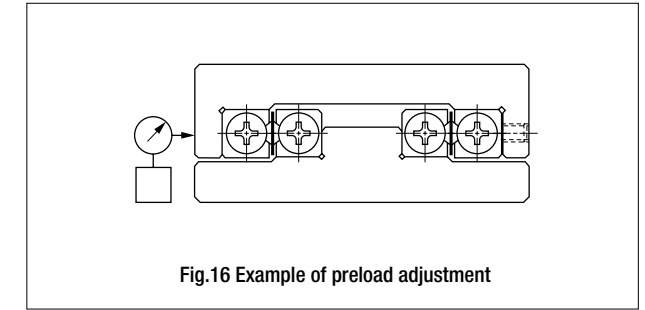

Fig.16 Example of preload adjustment

### 7 Final fixing of the way at adjusting side

- The mounting screws have been tightened lightly to a uniform torque. Similar to the adjustment of the preload adjusting screws, temporarily tighten the mounting screws at the adjusting side to a slightly lower tightening torque than the prescribed value. Start from the center screw of the way length and proceed alternately to the left and right.
- When tightening the mounting screws close to the end of the way, gradually stroke the table and ensure that the roller cage is positioned at the mounting screw.
- Finally, tighten all mounting screws at the adjusting side uniformly to the prescribed torque similar to the adjustment of the preload adjusting screws.

### 8 Final checking (Fig.17)

- Stroke the table gradually till its full stroke length, ensuring that the stroke is smooth and quiet.
- Check the operating accuracy by measuring the upper and side faces of table with a dial gauge.

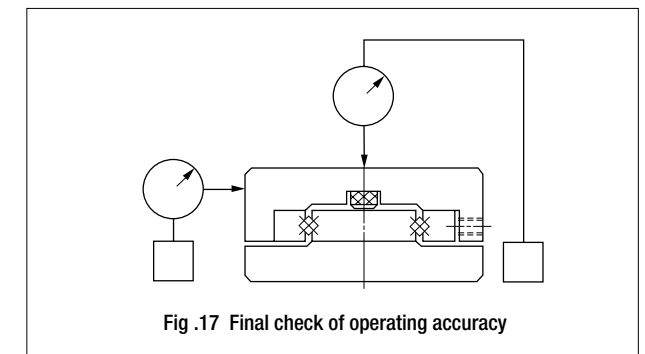
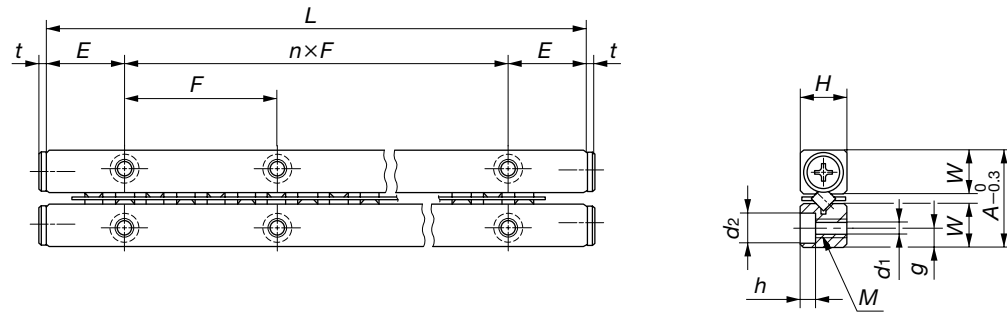

Fig.17 Final check of operating accuracy

## CRWG



Model number	Mass (Ref.)		Boundary dimensions				Nominal dimensions mm										
	Way <sup>(1)</sup> g	Roller cage <sup>(2)</sup> g	A	H	L (n×F)	E	Dw	R	Z	p	e						
CRWG 2- 30	6.53	0.38	12	6	30 (1×15)	7.5	2	25.6	4	4	2.8						
CRWG 2- 45	9.53	0.72			45 (2×15)			41.6	8								
CRWG 2- 60	12.5	0.88			60 (3×15)			49.6	10								
CRWG 2- 75	15.5	1.22			75 (4×15)			65.6	14								
CRWG 2- 90	18.5	1.39			90 (5×15)			73.6	16								
CRWG 2-105	21.5	1.72			105 (6×15)			89.6	20								
CRWG 2-120	24.5	1.89			120 (7×15)			97.6	22								
CRWG 2-135	27.5	2.22			135 (8×15)			113.6	26								
CRWG 2-150	30.5	2.39			150 (9×15)			121.6	28								
CRWG 3- 50	22.8	1.69			18			8	50 (1×25)			12.5	3	42	6	5	3.5
CRWG 3- 75	33.3	2.71	75 (2×25)	62		10											
CRWG 3-100	43.8	3.72	100 (3×25)	82		14											
CRWG 3-125	54.4	4.74	125 (4×25)	102		18											
CRWG 3-150	64.9	5.75	150 (5×25)	122		22											
CRWG 3-175	75.4	6.77	175 (6×25)	142		26											
CRWG 3-200	85.9	7.78	200 (7×25)	162		30											
CRWG 3-225	96.4	8.80	225 (8×25)	182		34											
CRWG 3-250	107	9.81	250 (9×25)	202		38											
CRWG 4- 80	59.6	9.70	22	11		80 (1×40)	20		4	73	8			7	5		
CRWG 4-120	88.0	12.0			120 (2×40)	101		12									
CRWG 4-160	116	14.3			160 (3×40)	129		16									
CRWG 4-200	145	16.7			200 (4×40)	157		20									
CRWG 4-240	173	20.1			240 (5×40)	199		26									
CRWG 4-280	201	22.5			280 (6×40)	227		30									
CRWG 4-320	230	24.8			320 (7×40)	255		34									
CRWG 6-100	147	12.0			31	15		100 (1×50)		25	6	75	6			9	6
CRWG 6-150	216	22.6						150 (2×50)				129	12				
CRWG 6-200	285	29.7						200 (3×50)				165	16				
CRWG 6-250	353	36.8	250 (4×50)	201			20										
CRWG 6-300	422	43.9	300 (5×50)	237			24										
CRWG 6-350	491	51.0	350 (6×50)	273			28										

Note<sup>(1)</sup>: The value shows the mass of one piece of way.  
<sup>(2)</sup>: The value shows the mass of one roller cage.  
<sup>(3)</sup>: Direction of basic dynamic load rating (C), basic static load rating (C<sub>0</sub>) and allowable load (F) is shown in below.

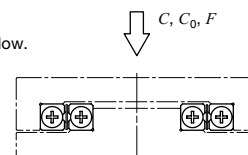

Mounting dimensions							Maximum stroke length mm	Basic dynamic load rating <sup>(3)</sup> C N	Basic static load rating <sup>(3)</sup> C <sub>0</sub> N	Allowable load <sup>(2)</sup> F N	Model number
W	g	M	d <sub>1</sub>	d <sub>2</sub>	h	t					
5.5	2.5	M3	2.55	4.4	2	1.5	9	913	1 180	392	CRWG 2- 30
							7	1 570	2 350	783	CRWG 2- 45
							21	1 860	2 940	979	CRWG 2- 60
							19	2 420	4 110	1 370	CRWG 2- 75
							33	2 680	4 700	1 570	CRWG 2- 90
							31	3 190	5 880	1 960	CRWG 2-105
							45	3 440	6 460	2 150	CRWG 2-120
							43	3 910	7 640	2 550	CRWG 2-135
							57	4 150	8 230	2 740	CRWG 2-150
							8.3	3.5	M4	3.3	6
23	4 080	6 090	2 030	CRWG 3- 75							
33	5 300	8 530	2 840	CRWG 3-100							
43	6 440	11 000	3 660	CRWG 3-125							
53	7 530	13 400	4 470	CRWG 3-150							
63	8 570	15 800	5 280	CRWG 3-175							
73	9 580	18 300	6 090	CRWG 3-200							
83	10 600	20 700	6 910	CRWG 3-225							
93	11 500	23 200	7 720	CRWG 3-250							
10	4.5	M5	4.3	7.5	4.1	2					
							38	9 180	14 100	4 700	CRWG 4-120
							62	11 500	18 800	6 270	CRWG 4-160
							86	13 700	23 500	7 830	CRWG 4-200
							82	16 700	30 600	10 200	CRWG 4-240
							106	18 700	35 300	11 800	CRWG 4-280
							129	20 600	40 000	13 300	CRWG 4-320
							48	11 200	13 800	4 610	CRWG 6-100
							40	19 300	27 700	9 230	CRWG 6-150
							68	24 100	36 900	12 300	CRWG 6-200
96	28 700	46 100	15 400	CRWG 6-250							
124	33 000	55 400	18 500	CRWG 6-300							
151	37 200	64 600	21 500	CRWG 6-350							

### Example of identification number

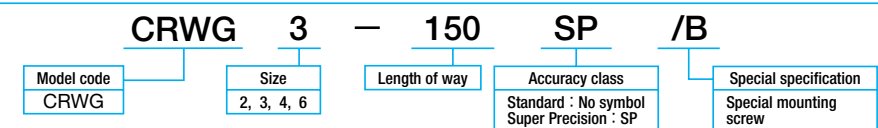

1N=0.102kgf=0.2248lbs.  
1mm=0.03937inch

U.S. PATENTED

# Anti-Creep Cage Crossed Roller Way Unit

## CRWUG

**IKO** Anti-Creep Cage Crossed Roller Way Unit is the product with a cage creep proof function using a rack and pinion mechanism originated from **IKO** Crossed Roller Way, featuring smooth linear motion with super high accuracy.

### Freedom in mounting

This series is reliable for applications such as a vertical axis where Crossed Roller Way Unit may have chances of cage creep.

### Interchangeable in dimensions

CRWUG are dimensionally interchangeable to **IKO** Crossed Roller Way Unit. Since they have the same external dimensions to those of the existing Crossed Roller Way Unit, existing Crossed Roller Way Unit can be replaced without any modification.

### High-speed operation

Any corrective operation for cage creep is not necessary even for a longtime operation. Energy saving in the operation is possible.

### Smooth and accurate operation

Combination of precisely finished raceways and non-recirculating cages with super high precision rollers provides superbly smooth motion with very high accuracy.

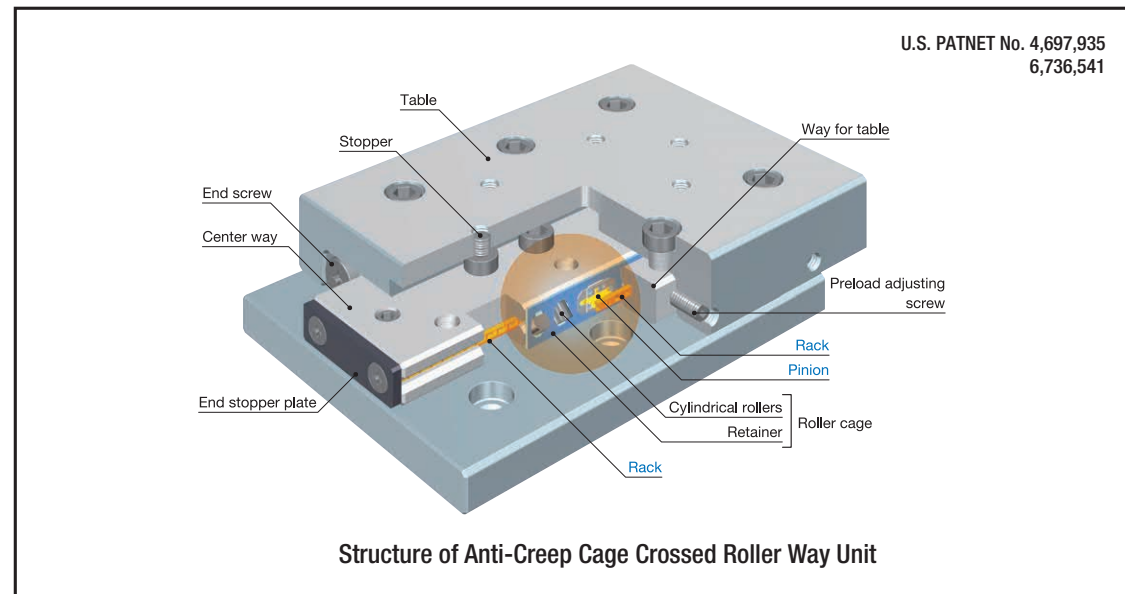

## Anti-Creep Cage Crossed Roller Way Unit series

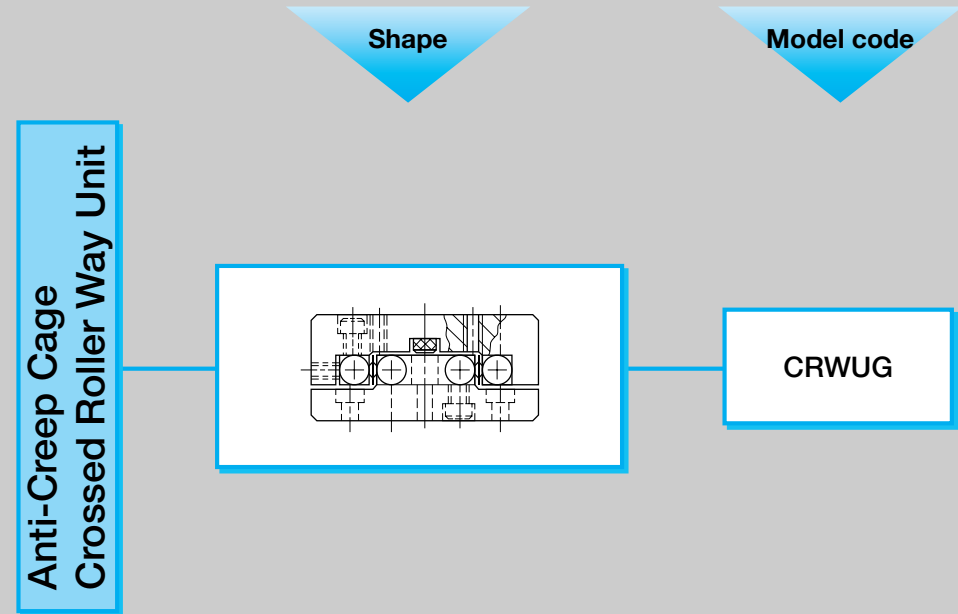

## ● Identification Number of Anti-Creep Cage Crossed Roller Way Unit

The specification of Anti-Creep Cage Crossed Roller Way Unit is indicated by the model number. Indicate each specification by using a model code and size.

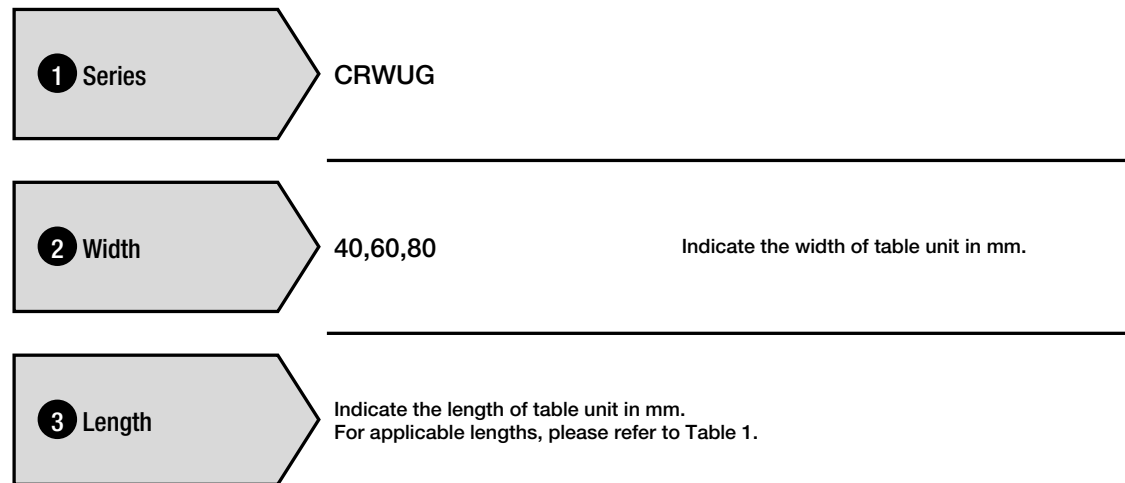
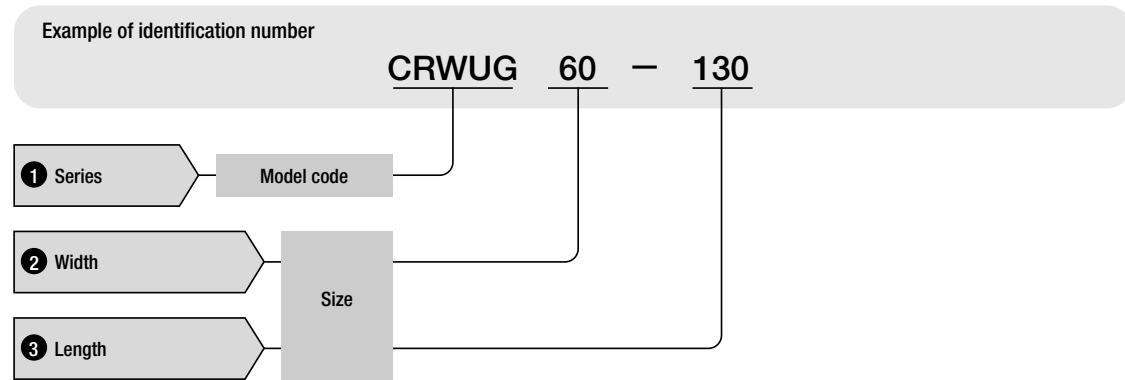

Table 1 Length of table unit

Model number	Length mm						
<b>CRWUG 40</b>	35	50	65	80	95	110	125
<b>CRWUG 60</b>	55	80	105	130	155	—	—
<b>CRWUG 80</b>	85	125	165	205	—	—	—

## Load Rating and Allowable Load

Summarized descriptions of load ratings of Anti-Creep Cage Crossed Roller Way Unit are given below. For details of load rating definitions and load calculations, see "General description". The load ratings for upward and lateral loads of Anti-Creep Cage Crossed Roller Way Unit are the same as those for downward load.

### ● Basic dynamic load rating $C$

The basic dynamic load rating is defined as the constant load both in direction and magnitude under which a group of identical Anti-Creep Cage Crossed Roller Way Units are individually operated and 90% of the units in the group can travel  $100 \times 10^3$  meters free from material damage due to rolling contact fatigue.

### ● Basic static load rating $C_0$

The basic static load rating is defined as the static load that gives a prescribed constant contact stress at the center of the contact area between the rolling element and raceway receiving the maximum load.

### ● Allowable load $F$

The allowable load is a load under which the sum of elastic deformations of the rolling element and the raceway in the contact area subjected to the maximum contact stress is small enough to guarantee accuracy and smooth rolling movement. Therefore, when very smooth and highly accurate linear motion is required, make sure that the applied load on Anti-Creep Cage Crossed Roller Way Unit is well within the allowable load value.

### ● Static moment rating $T_0$

The static moment rating is defined as the static moment load that gives a prescribed constant contact stress at the center of the contact area between the rolling element and raceway receiving the maximum load when a moment is loaded.

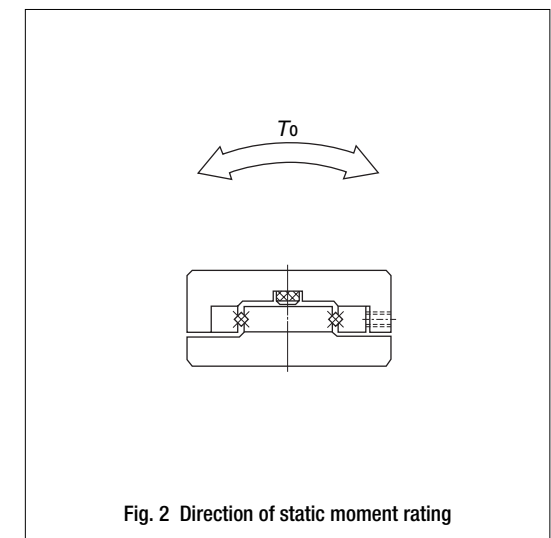
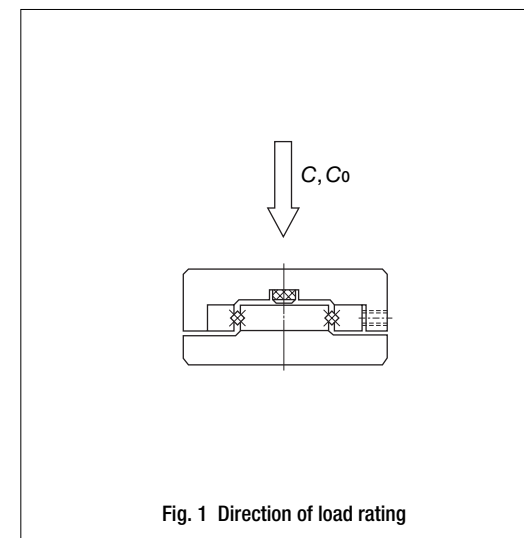



## Accuracy

The accuracy of Anti-Creep Cage Crossed Roller Way Unit is shown in Table 2.

Parallelism at the table center shows the difference between the maximum and the minimum of table height when the table is stroked.

Parallelism at table side shows the difference between the maximum and the minimum of measured values at the table side (opposite to adjusting side) when the table is stroked.

The standard height tolerance of the unit is  $\pm 0.1$  mm. If several units are used on the same mounting surface and the height of those units require a limited height variation, units with a height variation of less than 0.01 mm among the several units to be used on the same mounting surface can be supplied on request.

If a special accuracy other than those shown in Table 2 is required, consult **IKO**.

Table 2 Accuracy of Anti-Creep Cage Crossed Roller Way Unit

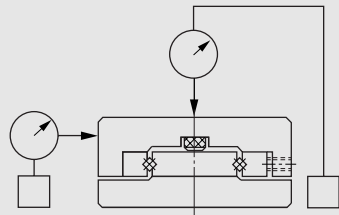

unit :  $\mu\text{m}$

Unit length mm		Parallelism at table center	Parallelism at table side
over	incl.		
—	50	2	4
50	100	2	5
100	160	3	6
160	310	3	7

## Precautions for Mounting and Use

### 1 Specifications of product

Check if the operating characteristics of the selected Anti-Creep Cage Crossed Roller Way Unit are suitable for the application of the machine or equipment.

### 2 Handling

Anti-Creep Cage Crossed Roller Way Unit are finished in production very accurately, so handle carefully. A pinion is assembled in the roller cage. If the cage is dropped or handled roughly, the pinion may come off. As cutting off the cage may cause the pinion coming off or damage to the pinion mounting part, so please avoid cutting off the cage. A rack is assembled in the way and fixed its position with the and screws. When assembling, the rack may come out from the way by removing the and screws.

### 3 Preload re-adjustment

Preload of Anti-Creep Cage Crossed Roller Way Unit is adjusted to zero or minimal amount of preload in the delivery.

- Preload adjustment is done only when mounting screws for the way at the adjusting side are temporarily tightened lightly.
- Preload adjustment is started from the adjusting screw at the center of the way length, proceeding alternately to the left and right.
- While checking the clearance (deflection) at the side surface of table, tighten each amount, then repeat the same process applying a higher tightening torque until a dial gauge indicates zero-clearance. (No more change in deflection) Record the tightening torque of the adjusting screws at zero-clearance.
- When adjusting the screws close to the end of the way, gradually stroke the table and ensure that the roller cage is positioned at the adjusting screws.
- Using the above process, the internal clearance becomes zero or minimal amount of preload, but the preload amount is not uniform along the way length. Therefore, repeat the same process tighten all adjusting screws uniformly to the recorded tightening torque.

Fig. 3 Example of preload adjustment

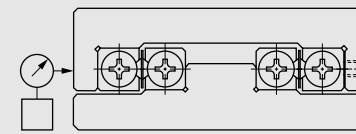

### 4 Maximum operating temperature

Anti-Creep Cage Crossed Roller Way Unit contains synthetic resin parts. Accordingly, the maximum operating temperature is 120°C.

In case of continuous operation, operating temperature should not exceed 100°C.

### 5 Maximum speed

The operating speed of Anti-Creep Cage Crossed Roller Way Unit should not exceed 30m/min.

### 6 Tightening torque of mounting screws

Tightening torque of mounting screws is shown in Table 3. If vibration or shock is large, or moment load is applied, it is recommended to tighten the screws by about 1.3 times the values shown in Table 3. If vibration and shock are not present and high operating accuracy is needed, a lower tightening torque than the values shown in Table 3 is suggested. In this case, adhesive or lock-screws may be used to prevent any subsequent loosening of the mounting screws.

Table 3 Tightening torque of screws

Screw size	Tightening torque N·m
M2 ×0.4	0.23
M3 ×0.5	1.4
M4 ×0.7	3.2
M5 ×0.8	6.3
M6 ×1	10.7

Remark : If the screw sizes on table side and bed side are different, use the tightening torque of the smaller screw size for both screws.

## CRWUG

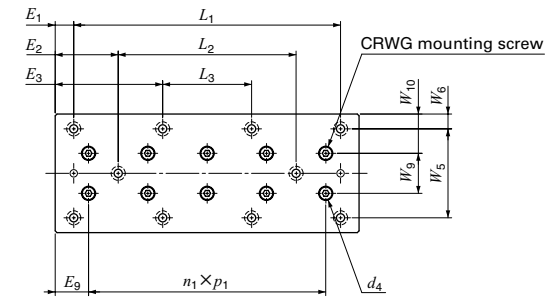
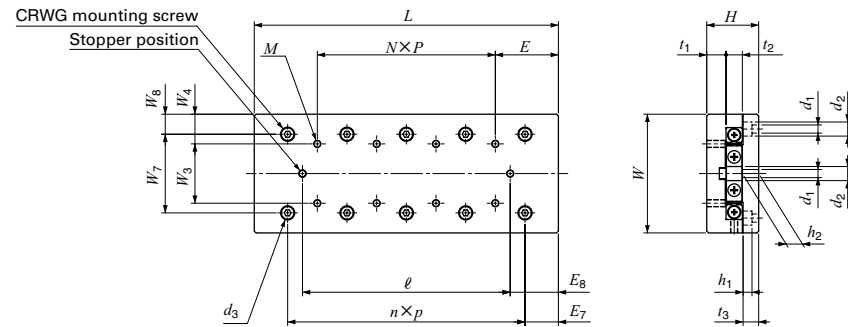

Model number	Mass (Ref.) Kg	Boundary dimensions mm							Nominal dimensions mm												
		W Tolerance	H Tolerance	L	t1	t2	t3	Maximum stroke length	Table				Bed								
								W3	W4	N x P	E	M	W5	W6	L1	E1	L2	E2	L3	E3	d1
CRWUG 40- 35	0.21			35	8	6	6.5	18		—					25		—	—	—		
CRWUG 40- 50	0.30			50				30		1 x 15					40		—	—	—		
CRWUG 40- 65	0.36			65				40		2 x 15					55		—	—	—		
CRWUG 40- 80	0.47	40 ±0.1	21 ±0.1	80	7	8	5.5	50	15	3 x 15	17.5	M3	30	5	70	5.0	—	—	40	20	3.5
CRWUG 40- 95	0.53			95				60		4 x 15					85		—	—	55	20	
CRWUG 40-110	0.63			110				70		5 x 15					100		—	—	70	20	
CRWUG 40-125	0.70			125				80		6 x 15					115		—	—	85	20	
CRWUG 60- 55	0.67			55				30		—					35		—	—	—		
CRWUG 60- 80	0.99			80				45		1 x 25					60		—	—	—		
CRWUG 60-105	1.28	60 ±0.1	28 ±0.1	105	10.5	8	9	60	25	2 x 25	27.5	M4	40	10	85	10.0	—	—	—		4.5
CRWUG 60-130	1.57			130				75		3 x 25					110		—	—	—		
CRWUG 60-155	1.86			155				90		4 x 25					135		85	35	—		
CRWUG 80- 85	1.78			85				50		—					40		—	—	—		
CRWUG 80-125	2.56	80 ±0.1	35 ±0.1	125	13	11	10.5	75	40	1 x 40	42.5	M5	60	10	80	22.5	—	—	—		5.5
CRWUG 80-165	3.34			165				105		2 x 40					120		—	—	—		
CRWUG 80-205	4.12			205				135		3 x 40					160		—	—	80	62.5	

Note(1) : Directions of basic dynamic load rating (C) , basic static load rating (C<sub>0</sub>) , allowable load (F) and static moment rating (T<sub>0</sub>) are shown in below.

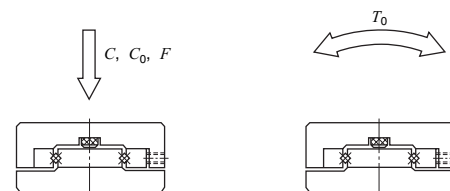

d2	h1	h2	Stopper and CRWUG mounting dimension mm													Basic dynamic load rating(1) C N	Basic static load rating(1) C <sub>0</sub> N	Allowable load(1) F N	Static moment rating(1) T <sub>0</sub> N·m	Model number
			W7	W8	n x p	E7	d3	ℓ	E8	W9	W10	n1 x p1	E9	d4						
6	3.2	6	25.5	7.25	1 x 15	10	6	29	3	6.5	—	20	1 x 15	10	6	913	1 180	392	10.6	CRWUG 40- 35
					1 x 25	12.5	41	4.5	2 x 15				10	2 000		2 440	813	17.7	CRWUG 40- 50	
					1 x 25	20	51	7	2 x 15				17.5	2 000		2 440	813	17.7	CRWUG 40- 65	
					2 x 25	15	61	9.5	4 x 15				10	3 430		4 880	1 630	35.3	CRWUG 40- 80	
					2 x 25	22.5	71	12	4 x 15				17.5	2 740		3 660	1 220	26.5	CRWUG 40- 95	
					3 x 25	17.5	81	14.5	5 x 15				17.5	4 080		6 090	2 030	44.2	CRWUG 40-110	
7.5	4.5	9.5	40	10	1 x 25		44	5.5	7.5	17	21.5	1 x 25		7.5	2 000	2 440	813	35.3	CRWUG 60- 55	
					2 x 25		59	10.5				2 x 25			3 430	4 880	1 630	70.7	CRWUG 60- 80	
					3 x 25	15	74	15.5				3 x 25	15		4 700	7 310	2 440	106	CRWUG 60-105	
					4 x 25		89	20.5				4 x 25			5 300	8 530	2 840	124	CRWUG 60-130	
					5 x 25		104	25.5				5 x 25			6 440	11 000	3 660	159	CRWUG 60-155	
9.5	6	11	54	13	1 x 40		64	10.5	9.5	27	26.5	1 x 40		9.5	5 350	7 050	2 350	145	CRWUG 80- 85	
					2 x 40		89	18				2 x 40			7 960	11 800	3 920	241	CRWUG 80-125	
					3 x 40		119	23				3 x 40			9 180	14 100	4 700	289	CRWUG 80-165	
					4 x 40		149	28				4 x 40			11 500	18 800	6 270	385	CRWUG 80-205	

### Example of identification number

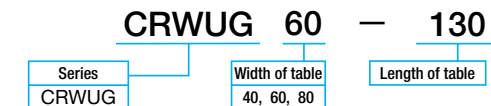

# Crossed Roller Way

## CRW/CRWM

**IKO** Crossed Roller Way is a linear motion rolling guide in which a roller cage is incorporated between two ways with V-shaped raceways. As the cylindrical rollers are alternately crossed, Crossed Roller Way can receive loads in any direction and can achieve very smooth linear motion with very high accuracy.

Wide variations in size are available for selections suitable for each application.

### Standard type and module type

Two types are available: the standard type and the module type. In the standard type four ways and two roller cages are used as one set, while in the module type two inner ways are integrated into a single piece.

### Very smooth operation

Precisely finished raceways are combined with roller cages, in which the length of super precise rollers is accurately controlled to avoid skewing. Very smooth linear motion with very little frictional resistance and free from stick-slip can be achieved.

### High carbon chromium bearing steel type and stainless steel type

Standard types include high carbon chromium bearing steel type and stainless steel type.

### Easy mounting

The mounting holes of the ways are female thread holes with a counter bore. So the mounting method is flexible, allowing the ways to be mounted either by using the female threads of the ways together with bolts inserted through the holes prepared on machines or by using the female threads prepared on machines. Mounting structure can be designed freely.

Two inner ways of module type are integrated into a single piece. The mounting structure can be made simple and, furthermore, as errors from extra machining of the mounting parts can be avoided, accuracy of linear motion can be improved.

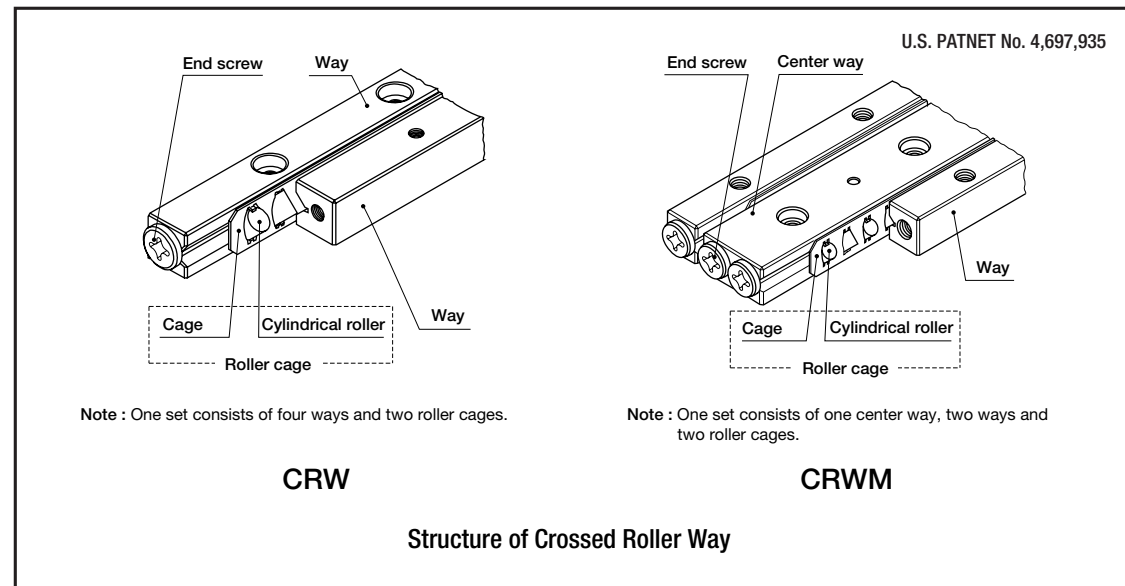

## Crossed Roller Way series

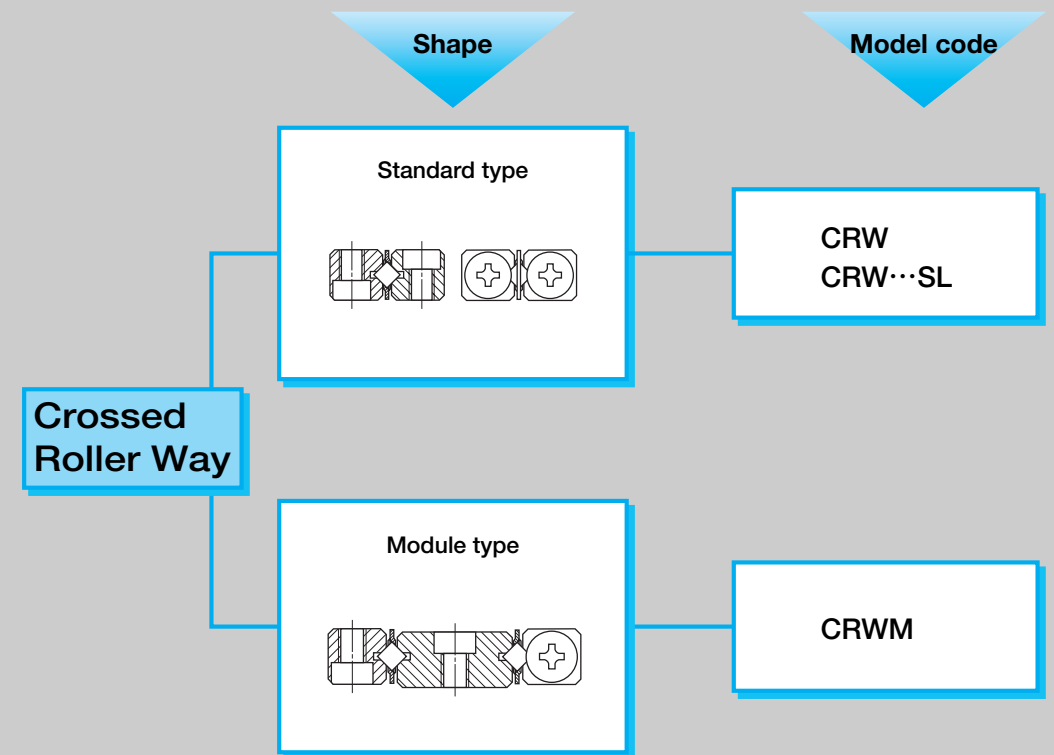

Remark : Models with "SL" are stainless steel type.

## ● Identification number and specification

The specification of Crossed Roller Way is indicated by the identification number, consisting of a model code, a size, a part code, a material symbol, a classification symbol and any supplemental codes.

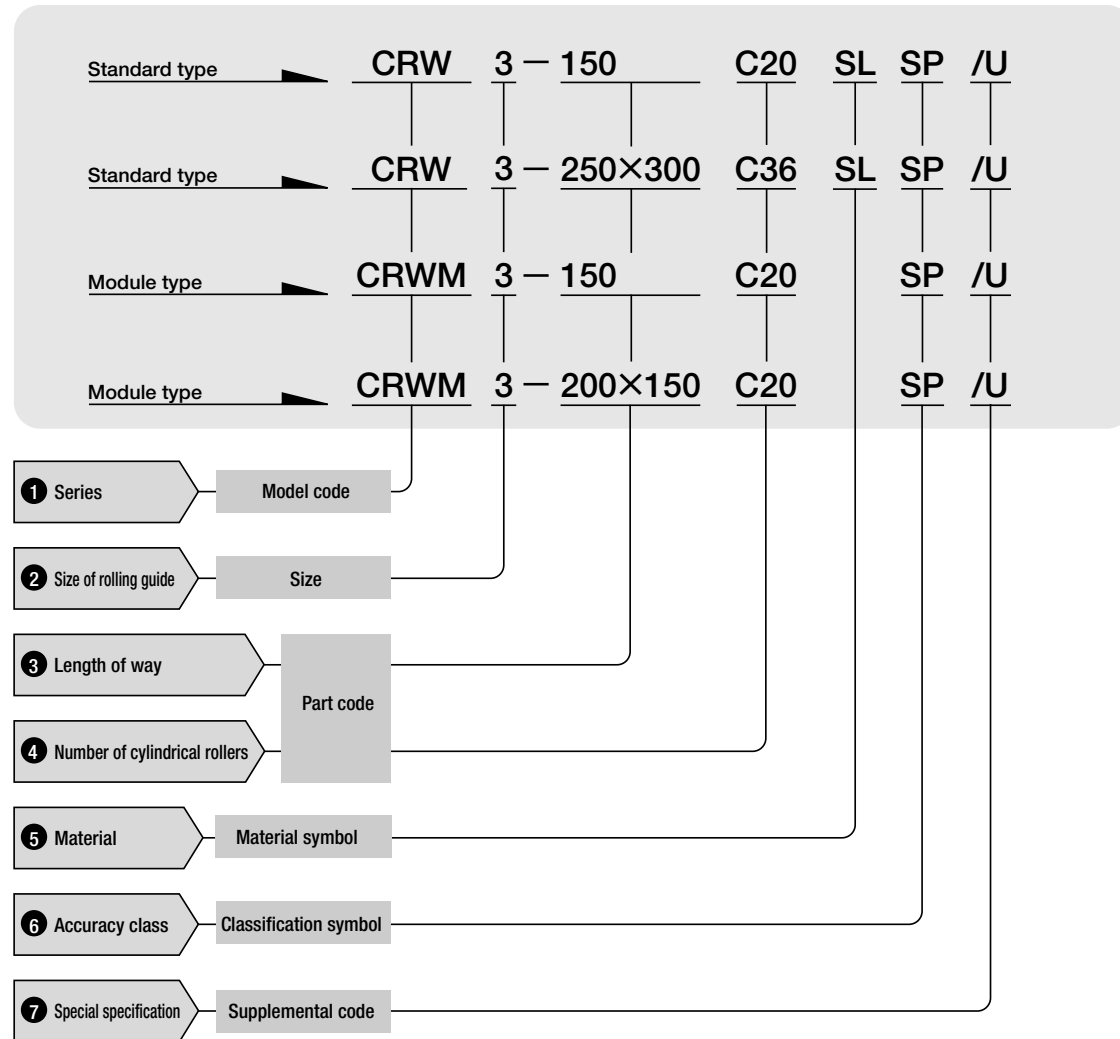

Standard type : CRW  
Module type : CRWM

For available models and sizes, see Table 1.

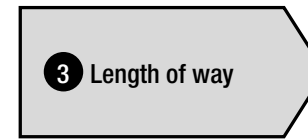
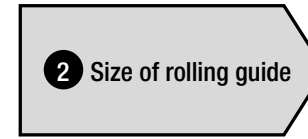

○  
○×○

Indicate the length of way in mm. Ways with different lengths can be combined. For the lengths of ways, see the table of dimensions. To indicate a combination of ways with different lengths, see "Combination of way lengths".

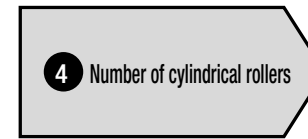

No symbol  
C○

The number of cylindrical rollers incorporated in one cage is indicated. When this number is not indicated, the number of cylindrical rollers shown in the table of dimensions are incorporated in one cage.

### Combination of way lengths

#### Combination for the standard type

One set consists of two short ways and two long ways together with two roller cages. As standard, the number of rollers in one cage is the number of rollers for the shorter of the two way lengths shown in the dimension tables. If a different number of rollers is required, indicate it in the identification number.

Example

CRW 6 - 300 × 400 C24

24 pcs. of rollers incorporated in one cage  
Long way length : 400 mm  
Short way length : 300 mm

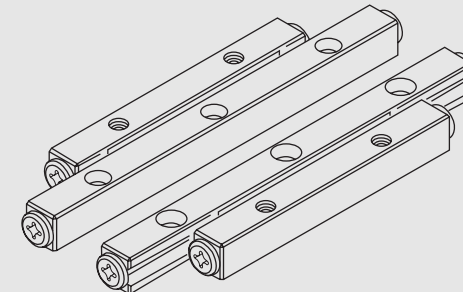

#### Combination for the module type

One set consists of one center way, two ways together with two roller cages. As standard, the number of rollers in one cage is the number of rollers for the shorter of the two way lengths shown in the dimension tables. If a different number of rollers is required, indicate it in the identification number.

Example

CRWM 3 - 200 × 150 C20

20 pcs. of rollers incorporated in one cage  
Way length : 150 mm  
Center way length : 200 mm

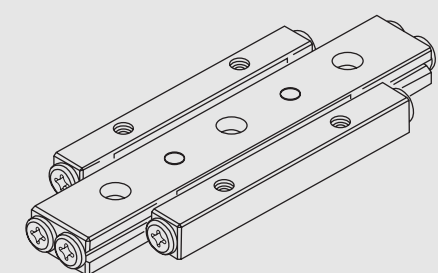

**5 Material**

High carbon steel made : No symbol  
 Stainless steel made : **SL** For applicable material types, see Table 1.

**Table 1 Types and sizes**

Size	Type	Standard type		Module type
		High carbon steel made	Stainless steel made	High carbon steel made
1		○	○	○
2		○	○	○
3		○	○	○
4		○	○	○
6		○	○	—
9		○	—	—
12		○	—	—
15		○	—	—
18		○	—	—
24		○	—	—

**6 Accuracy class**

Standard : No symbol For the allowable values of parallelism of the raceway to the reference mounting surface and of parallelism between two raceways of CRWM, see Fig. 1.  
 Super precision : **SP**

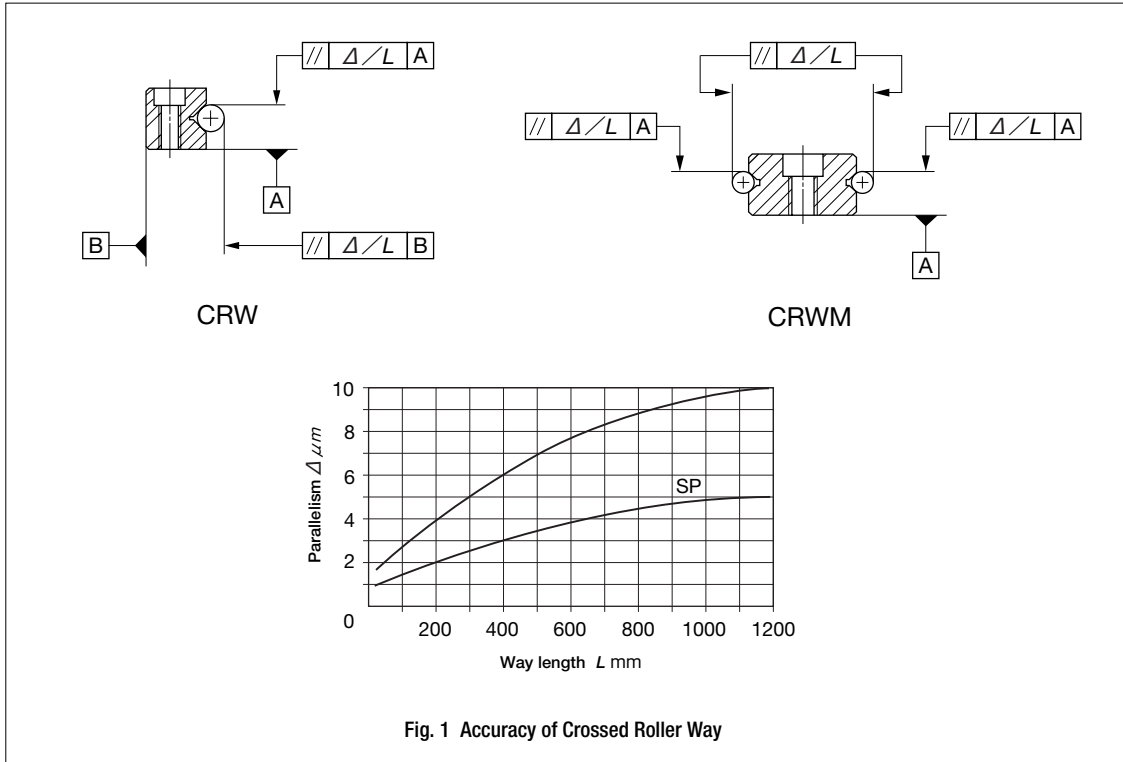

**7 Special specification**

For applicable special specifications, see Table 2.  
 When several special specifications are required, see Table 3.  
 For details of special specifications, see page E-32.

**Table 2 Special specifications**

Special specification	Supplemental code	Standard type		Module type
		High carbon steel made	Stainless steel made	High carbon steel made
Special mounting screws	<b>B</b>	○ <sup>(1)</sup>	—	○ <sup>(1)</sup>
High rigidity roller cage	<b>M</b>	○ <sup>(2)</sup>	○ <sup>(2)</sup>	—
End stopper SA	<b>SA</b>	○ <sup>(3)</sup>	○ <sup>(3)</sup>	○ <sup>(3)</sup>
End stopper SB	<b>SB</b>	○ <sup>(3)</sup>	○ <sup>(3)</sup>	○ <sup>(3)</sup>
Wiper seal	<b>U</b>	○ <sup>(3)</sup>	○ <sup>(3)</sup>	○ <sup>(3)</sup>

Note<sup>(1)</sup> : Not applicable to size 1 and 2 models.  
<sup>(2)</sup> : Not applicable to size 1, 2, 3 and 4 models.  
<sup>(3)</sup> : Not applicable to size 1 models.

**Table 3 Combinations of special specifications**

M	○			
SA	○	○		
SB	○	○	—	
U	○	○	—	—
	B	M	SA	SB

Remark 1 : In the table, the mark — indicates that this combination can not be made.  
 2 : When several special specifications are required, arrange the supplemental codes alphabetically.

## Special specifications

Details of special specifications of Crossed Roller Way are shown below. Indicate any specification by adding the supplemental code to the end of the identification number.

### Special mounting screws /B

Since the way at the adjusting side moves when the preload is set, some clearance between the mounting screw and the mounting hole is necessary. However, if sufficient clearance can not be provided or if the mounting screw is fixed from the way side to the table as shown in Fig. 2, special mounting screws may be needed.

Further, if the positioning accuracy of mounting holes in table or bed are not good, special screws can also be used. The special mounting screws are delivered as appended parts upon request, but available in carbon steel type only.

Table 4 Dimensions of special mounting screws

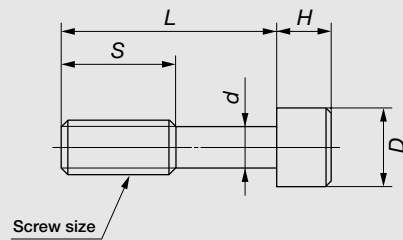

unit : mm

Size	Screw size	d	D	H	L	S
3	M 3	2.3	5	3	12	5
4	M 4	3.1	6	4	15	6
6	M 5	3.9	8	5	20	8
9	M 6	4.6	8.5	6	30	12
12	M 8	6.2	11.5	8	40	17
15	M10	7.9	14	10	45	16
18	M12	9.6	16	12	50	19
24	M14	11.2	19.5	14	70	26

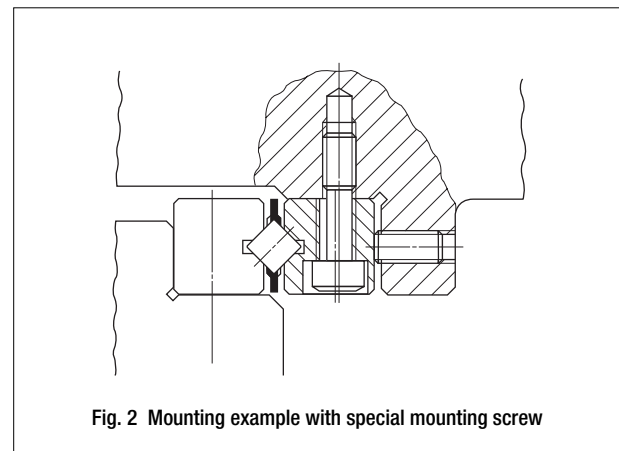

### High rigidity roller cage /M

High rigidity cages made of copper alloy, which are suitable for use in vertical applications, are optionally available. This cage is designed to prevent rollers from falling out in one direction. (See Fig. 3.)

For vertical usage, it is recommended to use this cage together with the end stopper SB.

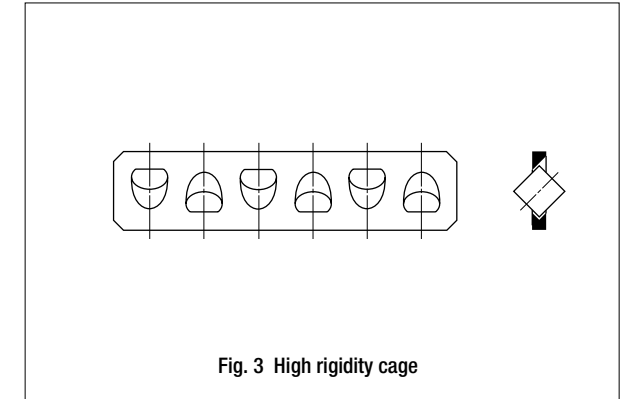

### End stopper SA /SA

When the cage is stroked frequently or subjected to vibration or unevenly distributed load, the cage position may shift while in operation. It is recommended, in such cases, to replace the end screw with the end stopper SA.

Size 1 models are assembled with stoppers similar to the SA end stopper as standard.

Table 5 Dimensions of end stopper SA

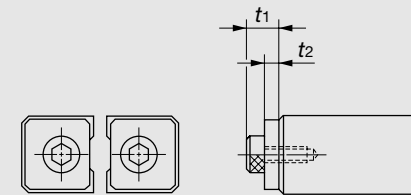

unit : mm

Size	t <sub>1</sub>	t <sub>2</sub>	Size	t <sub>1</sub>	t <sub>2</sub>
2	4.5	2	12	11	5
3	5	2	15	14	6
4	7	3	18	14	6
6	8	3	24	16	6
9	10	4			

## End stopper SB /SB

When the high rigidity cage is used on a vertical axis, the end screw is replaced with the end stopper SB to limit the stroking of the cage at the way end.

The end stopper SB can not be mounted on all ends of the ways in the assembly. Fig. 4 shows the standard mounting arrangement. The mounting arrangement can be changed by loosening screws and resetting the end stoppers.

Table 6 Dimensions of end stopper SB

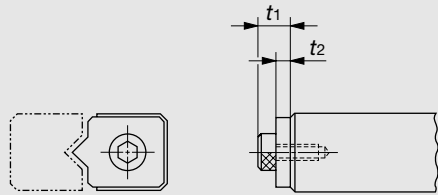

unit : mm					
Size	$t_1$	$t_2$	Size	$t_1$	$t_2$
2	4.5	2	12	11	5
3	5	2	15	14	6
4	7	3	18	14	6
6	8	3	24	16	6
9	10	4			

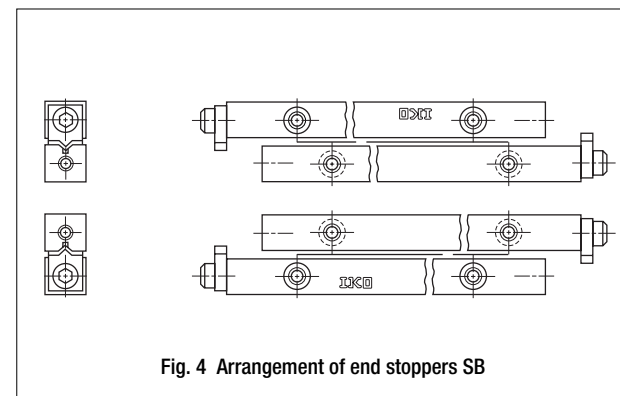

Fig. 4 Arrangement of end stoppers SB

## Wiper seal /U

The end screw is replaced with the wiper seal to prevent foreign particles from intruding into the raceways. The wiper seal also serves as the end stopper providing the same function as the end stopper SB.

The wiper seal cannot be mounted on every way end. Fig. 5 shows the standard mounting arrangement. The mounting arrangement can be changed by loosening screws and resetting the wiper seals.

Table 7 Dimensions of wiper seal

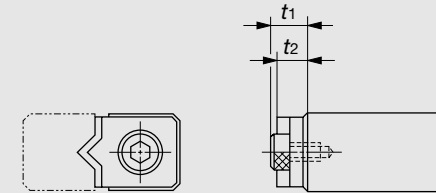

unit : mm					
Size	$t_1$	$t_2$	Size	$t_1$	$t_2$
2	4.5	4	12	11	8.5
3	5	4	15	14	11
4	7	6	18	14	11
6	8	6	24	16	11
9	10	7.5			

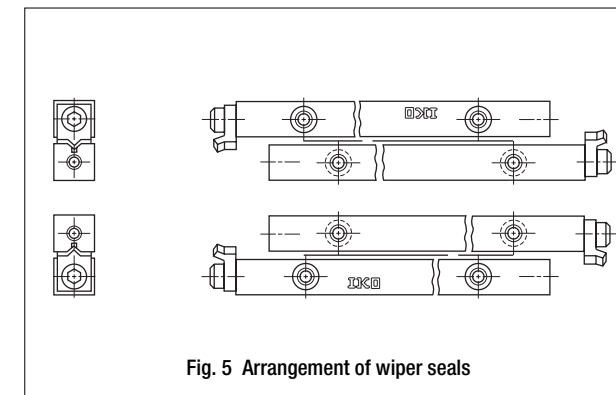

Fig. 5 Arrangement of wiper seals

# Load Rating and Allowable Load

Summarized descriptions of load ratings of Crossed Roller Way are given below. For details of load rating definitions and load calculations, see "General description".

## Basic dynamic load rating *C*

The basic dynamic load rating is defined as the constant load both in direction and magnitude under which a group of identical Crossed Roller Ways are individually operated and 90% of the units in the group can travel 100 x 10<sup>3</sup> meters free from material damage due to rolling contact fatigue.

## Basic static load rating *C<sub>0</sub>*

The basic static load rating is defined as the static load that gives a prescribed constant contact stress at the center of the contact area between the rolling element and raceway receiving the maximum load.

## Allowable load *F*

The allowable load is a load under which the sum of elastic deformations of the rolling element and the raceway in the contact area subjected to the maximum contact stress is small enough to guarantee accuracy and smooth rolling movement. Therefore, when very smooth and highly accurate linear motion is required, make sure that the applied load is well within the allowable load value.

## Calculation of load ratings and allowable load

In Crossed Roller Way, the number of cylindrical rollers sharing a load differs according to the load direction. Therefore, it is necessary to obtain load ratings and allowable load for each direction. The basic dynamic load rating *C<sub>u</sub>*, basic static load rating *C<sub>0u</sub>* and allowable load *F<sub>u</sub>* shown in the table of dimensions indicate values per one roller. The basic dynamic load rating *C*, basic static load rating *C<sub>0</sub>* and allowable load *F* of Crossed Roller Way are obtained from the formulae shown in Tables 8.1 and 8.2.

Table 8.1 Calculation formulae for load ratings and allowable loads of CRW

Load condition	Upward/downward load (1)	Lateral load
Basic dynamic load rating <i>C<sub>N</sub></i>	$C_r = \left\{ \left( \frac{Z}{2} - 1 \right) 2p \right\}^{1/36} \left( \frac{Z}{2} \right)^{3/4} C_{0U} \dots (1)$	$C_a = \left\{ \left( \frac{Z}{2} - 1 \right) 2p \right\}^{1/36} \left( \frac{Z}{2} \right)^{3/4} 2^{7/9} C_{0U} \dots (4)$
Basic static load rating <i>C<sub>0</sub></i>	$C_{0r} = \left( \frac{Z}{2} \right) C_{0U} \dots (2)$	$C_{0a} = 2 \left( \frac{Z}{2} \right) C_{0U} \dots (5)$
Allowable load <i>F</i>	$F_r = \left( \frac{Z}{2} \right) F_U \dots (3)$	$F_a = 2 \left( \frac{Z}{2} \right) F_U \dots (6)$
Meaning of symbols	<i>C<sub>r</sub></i> : Basic dynamic load rating for upward / downward load, N <i>C<sub>a</sub></i> : Basic dynamic load rating for lateral load, N <i>C<sub>0r</sub></i> : Basic static load rating for upward / downward load, N <i>C<sub>0a</sub></i> : Basic static load rating for lateral load, N <i>F<sub>r</sub></i> : Allowable load for upward / downward load, N <i>F<sub>a</sub></i> : Allowable load rating for lateral load, N <i>Z</i> : Number of cylindrical rollers incorporated in one roller cage (Disregard any decimal for <i>Z</i> /2) <i>p</i> : Pitch between cylindrical rollers, mm <i>C<sub>U</sub></i> : Basic dynamic load rating per one roller, N <i>C<sub>0U</sub></i> : Basic static load rating per one roller, N <i>F<sub>U</sub></i> : Allowable load per one roller, N	

Note(1) : When using one set of CRW type (four ways and two roller cages) in parallel in this load direction, use formulae (7), (8) and (9) in Table 8.2.

Table 8.2 Calculation formulae for load ratings and allowable loads of CRWM

Load condition	Upward/downward load	Lateral load
Basic dynamic load rating <i>C<sub>N</sub></i>	$C_r = \left\{ \left( \frac{Z}{2} - 1 \right) 2p \right\}^{1/36} \left( \frac{Z}{2} \right)^{3/4} 2^{7/9} C_{0U} \dots (7)$	$C_a = \left\{ \left( \frac{Z}{2} - 1 \right) 2p \right\}^{1/36} \left( \frac{Z}{2} \right)^{3/4} 2^{7/9} C_{0U} \dots (10)$
Basic static load rating <i>C<sub>0</sub></i>	$C_{0r} = 2 \left( \frac{Z}{2} \right) C_{0U} \dots (8)$	$C_{0a} = 2 \left( \frac{Z}{2} \right) C_{0U} \dots (11)$
Allowable load <i>F</i>	$F_r = 2 \left( \frac{Z}{2} \right) F_U \dots (9)$	$F_a = 2 \left( \frac{Z}{2} \right) F_U \dots (12)$
Meaning of symbols	<i>C<sub>r</sub></i> : Basic dynamic load rating for upward / downward load, N <i>C<sub>a</sub></i> : Basic dynamic load rating for lateral load, N <i>C<sub>0r</sub></i> : Basic static load rating for upward / downward load, N <i>C<sub>0a</sub></i> : Basic static load rating for lateral load, N <i>F<sub>r</sub></i> : Allowable load for upward / downward load, N <i>F<sub>a</sub></i> : Allowable load rating for lateral load, N <i>Z</i> : Number of cylindrical rollers incorporated in one roller cage (Disregard any decimal for <i>Z</i> /2) <i>p</i> : Pitch between cylindrical rollers, mm <i>C<sub>U</sub></i> : Basic dynamic load rating per one roller, N <i>C<sub>0U</sub></i> : Basic static load rating per one roller, N <i>F<sub>U</sub></i> : Allowable load per one roller, N	



# Selection of Specification

When selecting the specification of Crossed Roller Way, stroke length and number of rollers should be considered as well as the accuracy, load ratings and allowable load.

## ● Stroke length and number of rollers

Stroke length of Crossed Roller Way is related to the way length and number of rollers in a roller cage, etc. Therefore, selection procedure is as follows while considering the operating stroke length and applied loads.

### ① Calculation of way length

Way length is generally more than 1.5 times of operating stroke length and is obtained from the following formula.

$$L \geq 1.5S \quad \dots\dots\dots(10)$$

where,  $L$ : Way length, mm  
 $S$ : Operating stroke length, mm

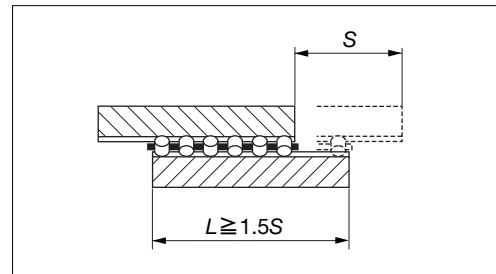

### ② Calculation of maximum stroke length

It is suggested that the operating stroke length is 80% or less of the maximum stroke length. The maximum stroke length is obtained from the following formula.

$$S_1 \geq \frac{1}{0.8} S \quad \dots\dots\dots(11)$$

where,  $S_1$ : Maximum stroke length, mm  
 $S$ : Operating stroke length, mm

### ③ Calculation of cage length and number of rollers

Cage length is determined by the way length and maximum stroke length. In calculation of cage length, the calculation method is different according to the specification of end screws, end stoppers, etc.

#### (1) With standard end screws or end stoppers SA (except size 1 models)

The distance between rollers at both ends in one cage is that way length minus half of maximum stroke length as in the following formula.

$$L_R = L - \frac{S_1}{2} \quad \dots\dots\dots(12)$$

where,  $L_R$ : Allowable distance between rollers at both ends in one cage, mm  
 $L$ : Way length, mm  
 $S_1$ : Maximum stroke length, mm

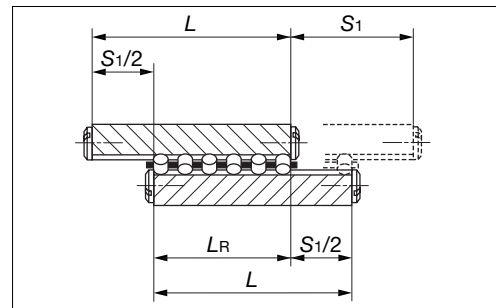

Number of rollers in one cage is obtained from the following formula.

$$Z = \frac{L_R - D_w}{p} + 1 \quad \dots\dots\dots(13)$$

where,  $Z$ : Number of rollers in one cage (Disregard any decimal.)  
 $L_R$ : Allowable distance between rollers at both ends in one cage, mm  
 $D_w$ : Roller diameter (See dimension tables.), mm  
 $p$ : Roller pitch (See dimension tables.), mm

#### (2) In case of size 1 models

Stroke length is limited by the cage and end stoppers. The cage length is obtained from the following formula.

$$R = L - \frac{S_1}{2} \quad \dots\dots\dots(14)$$

where,  $R$ : Allowable cage length, mm  
 $L$ : Way length, mm  
 $S_1$ : Maximum stroke length, mm

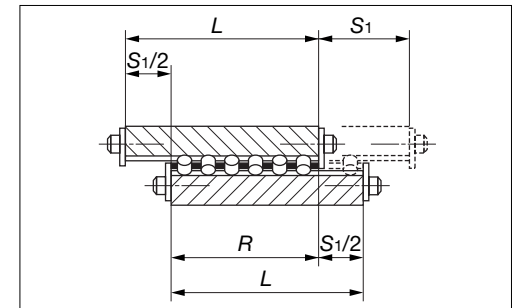

Number of rollers in one cage is obtained from the following formula.

$$Z = \frac{R - 2e}{p} + 1 \quad \dots\dots\dots(15)$$

where,  $Z$ : Number of rollers in one cage (Disregard any decimal.)  
 $R$ : Allowable cage length, mm  
 $e$ : End dimension of cage (See dimension tables.), mm  
 $p$ : Roller pitch (See dimension tables.), mm

#### (3) With end stoppers SB or wiper seals

Stroke length is limited by the cage and end stoppers or wiper seals. The cage length is obtained from the following formula.

$$R = L - t_2 - S_1 \quad \dots\dots\dots(16)$$

where,  $R$ : Allowable cage length, mm  
 $L$ : Way length, mm  
 $S_1$ : Maximum stroke length, mm  
 $t_2$ : Thickness of end stopper SB or wiper seal, mm (See Table 6 on page E-34 or Table 7 on page E-35.)

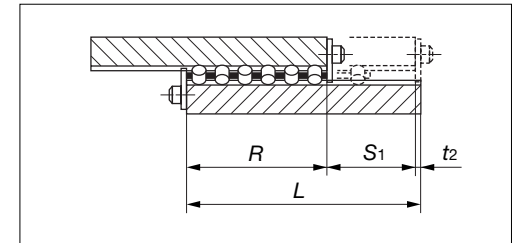

The number of rollers in a roller cage is obtained from formula (15) in the same way as size 1 models.

## ● Calculation example

Model..... CRW 6

Applied load.....  $P = 7000 \text{ N}$

Stroke length.....  $S = 195 \text{ mm}$

For parallel use of Crossed Roller Ways under the above specified conditions (See Fig. 12 on page E-45.), select the suitable specification.

### ① Calculation of way length

From formula (10), way length  $L$  is;

$$L \geq 1.5S = 1.5 \times 195 = 292.5$$

Therefore, standard way length  $L = 300 \text{ mm}$  is selected from dimension tables.

### ② Calculation of maximum stroke length

From formula (11), maximum stroke length  $S_1$  is;

$$S_1 \geq \frac{1}{0.8} S = \frac{1}{0.8} \times 195 \doteq 244$$

From formula (12), allowable distance between rollers at both ends in one cage  $L_R$  is;

$$L_R = L - \frac{S_1}{2} = 300 - \frac{244}{2} = 178$$

### ③ Calculation of number of rollers

From formula (13), number of rollers in one cage is;  
( $D_w = 6 \text{ mm}$  and  $p = 9 \text{ mm}$  from dimension tables)

$$Z = \frac{L_R - D_w}{p} + 1 = \frac{178 - 6}{9} + 1 \doteq 20.1$$

Therefore, number of rollers  $Z = 20$  in one cage is obtained by disregarding any decimal.

### ④ Calculation of allowable load

From formula (9) in Table 8.2 on page E-13, allowable load  $F$  in parallel usage is;  
(allowable load per one roller  $F_U = 764 \text{ N}$  from dimension tables)

$$F = 2 \left( \frac{Z}{2} \right) F_U = 2 \left( \frac{20}{2} \right) \times 769 = 15380$$

In the calculation result, the allowable load  $F$  is larger than the applied load  $P = 7000 \text{ N}$ . Therefore, this model can be used within the allowable load. If the applied load exceeds the calculated allowable load, it is necessary to consider increasing the way length and number of rollers, or to select a model with larger diameter rollers.

### ⑤ Determination of specification

As a result of the above calculations, CRW 6-300 with 20 rollers is suitable.  
The selected model number is CRW 6-300 C20.

## Lubrication and Dust Protection

Oil or grease is used as a lubricant for Crossed Roller Way. Oil is generally used for high speed or low friction operation. On the other hand, grease is used when operating speed is low. In case of grease lubrication, a good quality lithium-soap base grease is recommended. When operation speed is low and load is light, coat the raceways with grease before use and relubricate periodically. Structure shown in Fig. 6 makes the relubrication easy.

Crossed Roller Ways are finished very accurately. However, if dust or foreign particles intrude, life and accuracy will be adversely affected. In order to prevent the intrusion of dust, dirt, water, etc., it is recommended to use non-contact type shields (labyrinth seal) as shown in Fig. 7 or contact type wiper seals shown in Fig. 8 at the outside of installed unit.

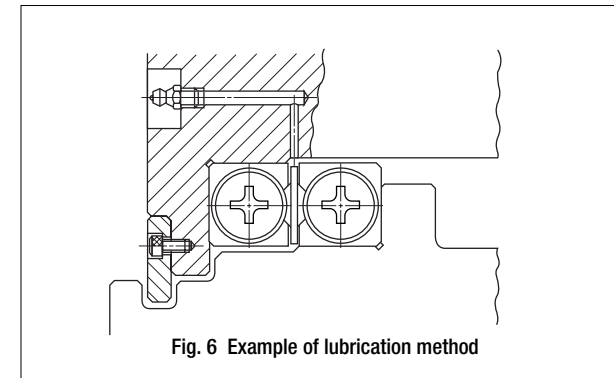

Fig. 6 Example of lubrication method

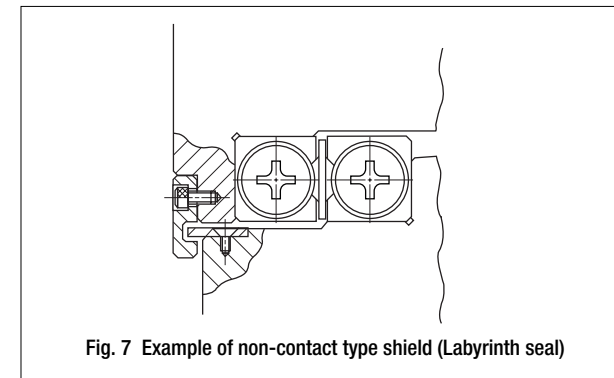

Fig. 7 Example of non-contact type shield (Labyrinth seal)

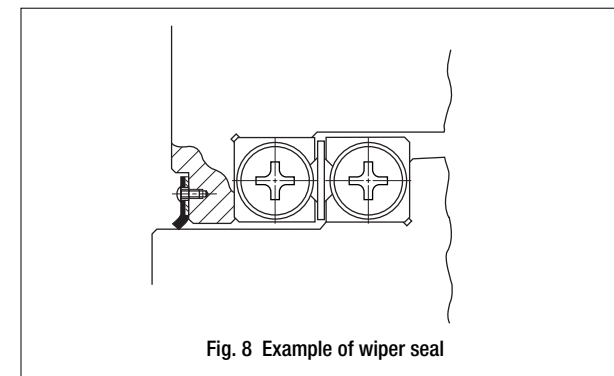

Fig. 8 Example of wiper seal

# Precautions for Use

## 1 Specification of Crossed Roller Way

Check whether the specification of selected Crossed Roller Way meets the requirements for the application of the machine or equipment.

## 2 Handling of Crossed Roller Way

Crossed Roller Way is a high precision product, so handle it with care. The cage can be modified by cutting it to the required cage length. When cutting, do not deform the cage.

## 3 Accuracy of mating mounting surfaces

The general configurations of mating mounting surfaces for CRW and CRWM are shown in Figs. 9.1 and 9.2, respectively.

Accuracy of the mating mounting surfaces is, in general, as shown in Table 9. The accuracy of mating mounting surfaces directly affects the operating accuracy and performance of Crossed Roller Way. If very high operating accuracy is required, higher accuracy of mating mounting surfaces than the values shown in Table 9 may be needed.

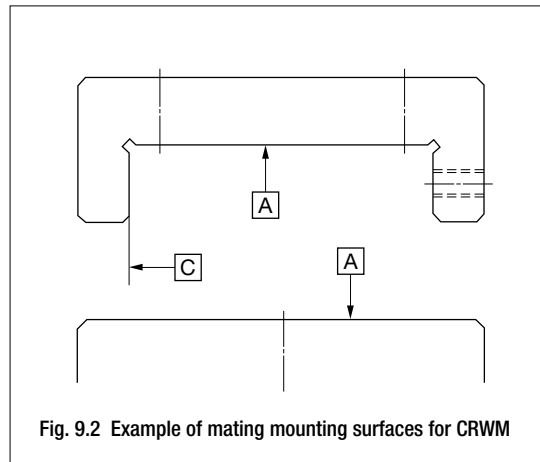
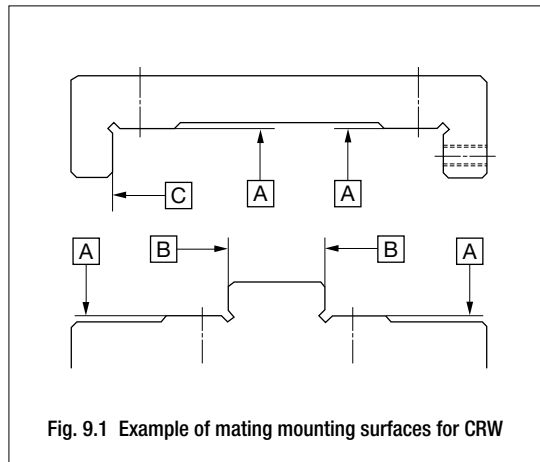

## 4 Preload method

Preload adjusting screws are generally used for setting preload, as shown in Fig. 10. The size of the preload adjusting screws are the same as that of the mounting screws for the ways. The position of the preload adjusting screws is at the same position as the mounting screws of the ways. For centering, use half of way height  $H$ .

Preload amounts differ according to the application of machine or equipment. Excessive preloads deteriorate life and often damage the raceways. Therefore, zero or minimal preload is recommended in general. If accuracy and rigidity are important, a setting plate as shown in Fig. 11.1 or a tapered jib as shown in Fig. 11.2 may be used.

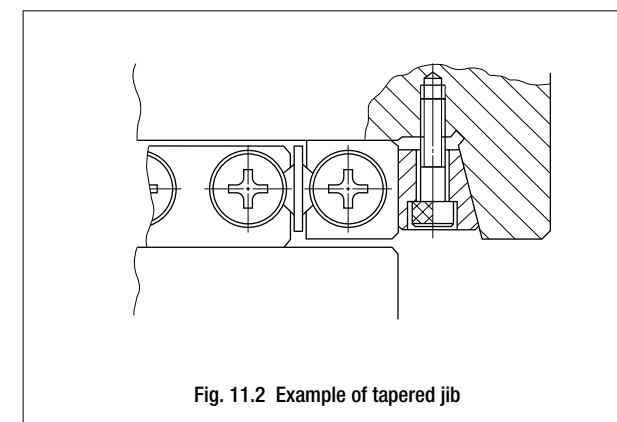
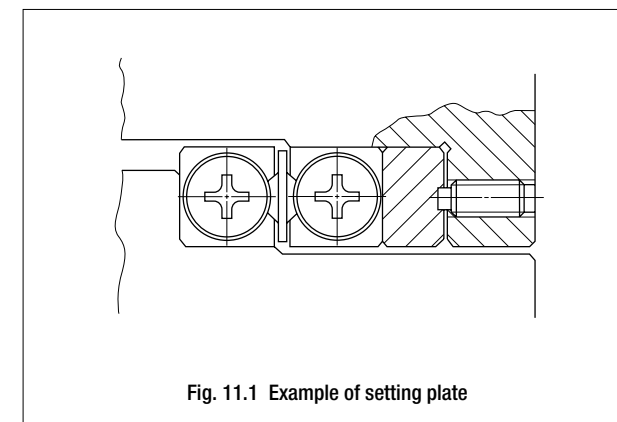
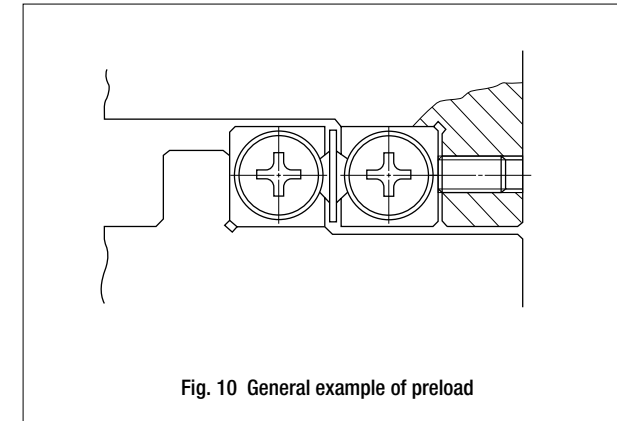

Table 9 Accuracy of mating mounting surfaces

<p><b>A</b> surface</p>	<ul style="list-style-type: none"> <li>This accuracy directly affects the operating accuracy.</li> <li>Flatness of <b>A</b> surface (four places) should be equal or nearly equal to the value of parallelism in Fig. 1 on page E-5.</li> </ul>
<p><b>B</b> and <b>C</b> surfaces</p>	<ul style="list-style-type: none"> <li>Flatness</li> <li>Flatness of these surfaces directly affects preload. The value of flatness should be equal or nearly equal to the value of parallelism in Fig. 1 on page E-6.</li> <li>Squareness</li> <li>Squareness to <b>A</b> surface affects the rigidity of assembled unit in the preload direction. Consequently, a high accuracy finish is necessary.</li> </ul>

5 Crossed Roller Way does not contain synthetic resin parts and can be operated at high temperatures. But, when the temperature exceeds 100°C, consult **IKO**.

6 The operating speed of Crossed Roller Way should not exceed 30 m/min.

7 Tightening torque of mounting screws

Tightening torque of mounting screws is shown in Table 10. If vibration or shock is large, or moment load is applied, it is recommended to tighten the screws to about 1.3 times the values shown in Table 10. If vibration and shock are not present and high operating accuracy is needed, a lower tightening torque than the values shown in Table 10 is suggested. In this case, adhesive or lock-screws may be used to prevent any subsequent loosening of the mounting screws.

**Table 10 Tightening torque of screws**

Screw size	Tightening torque N·m
M 2×0.4	0.23
M 3×0.5	1.4
M 4×0.7	3.2
M 5×0.8	6.3
M 6×1	10.7
M 8×1.25	25.6
M10×1.5	50.1
M12×1.75	86.5
M14×2	137
M16×2	211

Remark : If the screw sizes on table side and bed side are different, use the tightening torque of the smaller screw size for both screws.

Mounting

Mounting of CRW

A general method for mounting CRW is shown in Fig. 12. The general procedure is as follows.

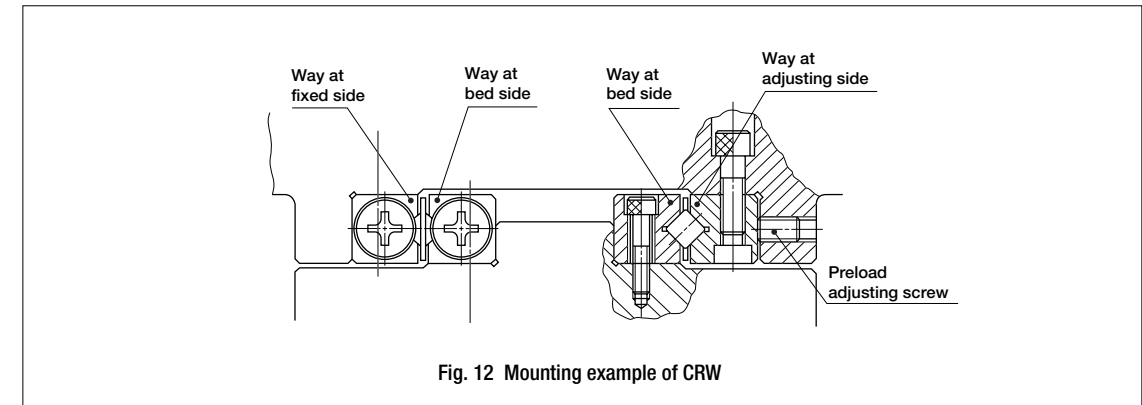

1 Preparation for mounting

- CRW is delivered as an individual package containing four ways and two roller cages. The ways in each package are not interchangeable with ways in other packages, so do not mix them.
- Separate the end screws or end stoppers and wash the ways with a clean cleaning agent. After cleaning, apply rust preventive oil or lubricating oil.

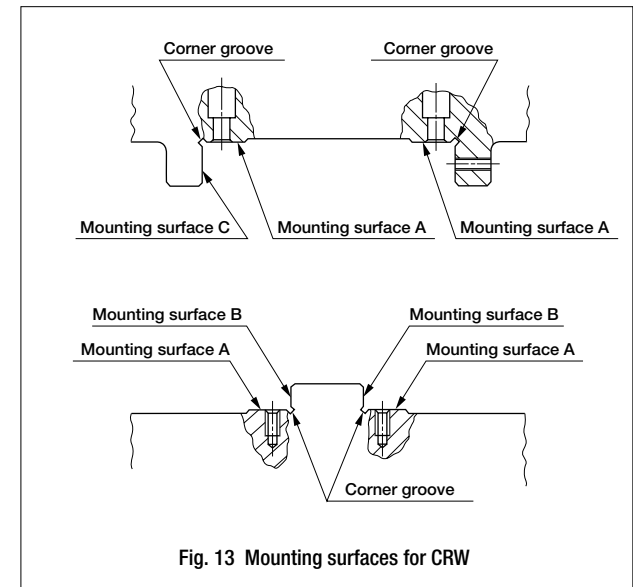

2 Cleaning of mounting surfaces of table and bed

- Remove burrs and blemishes from mounting surfaces of table and bed with an oil-stone, etc. During this process, also pay attention to the corner grooves of the mounting surfaces.
- Wipe off dust with clean cloth and apply rust preventive oil or lubricating oil.

**3 Mounting of ways at bed side (Fig. 14)**

- After fitting the mounting surfaces of ways onto the mating mounting surfaces of bed, temporarily tighten the mounting screws with uniform tightening torque.
- After closely fitting the ways to B surfaces (See Fig. 13.), tighten the mounting screws uniformly to the prescribed tightening torque.
- If high accuracy is required, tighten the mounting screws uniformly to the prescribed tightening torque while checking the parallelism of the two ways along the overall way length.
- General tightening torque of mounting screws is shown in Table 10 on page E-20.

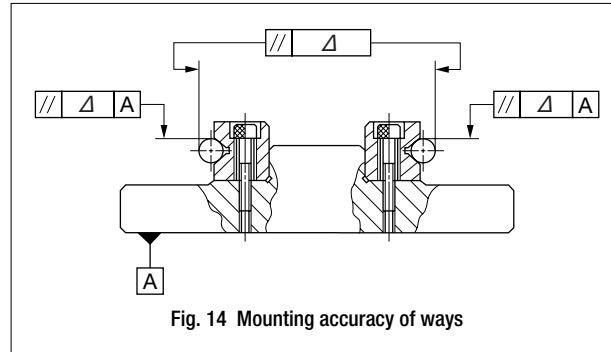

Fig. 14 Mounting accuracy of ways

**4 Mounting of ways at table side (Fig. 15)**

- After fitting the mounting surfaces of the way at the fixed side to the mating mounting surfaces of table, temporarily tighten the mounting screws at the fixed side with uniform tightening torque.
- After closely fitting the way at the fixed side to C surface, tighten the mounting screws at the fixed side uniformly to the prescribed tightening torque.
- Loosen the preload adjusting screws and temporarily tighten the mounting screws of the way at adjusting side with uniform and light tightening torque.

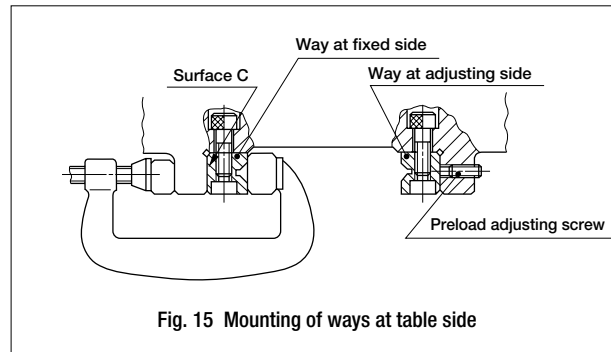

Fig. 15 Mounting of ways at table side

**5 Assembling of table and bed (Fig. 16)**

- Adjust the positions of table and bed in height and width directions in order to insert roller cages between the ways at table side and bed side.
- Insert the roller cages gradually and gently until the cages position roughly at the center of way length. In this process, do not deform the cages.
- Assemble end screws or end stoppers.
- Push the table to the preload adjusting side, and temporarily tighten the preload adjusting screws until the clearance at raceways is near zero.
- Gently stroke the table its full stroke length to position the roller cage at the center of the stroke.

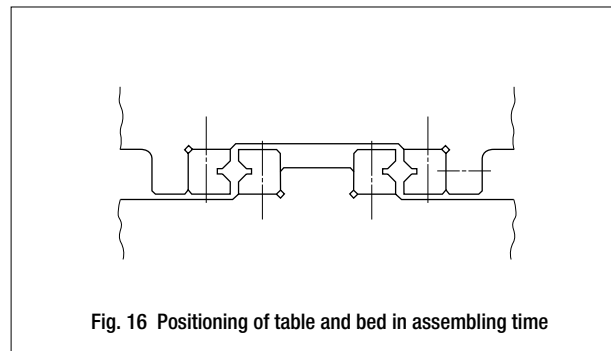

Fig. 16 Positioning of table and bed in assembling time

**6 Preload adjustment (Fig. 17)**

- Preload adjustment is done only when mounting screws for the way at the adjusting side are temporarily tightened.
- Preload adjustment is started from the adjusting screw at the center of the way length, proceeding alternately to the left and right.
- While checking the clearance (deflection) at the side face of table, tighten each adjusting screw lightly to a uniform amount, then repeat the same process applying a higher tightening torque until a dial gauge indicates zero-clearance (no more change in deflection). Record the tightening torque of the adjusting screws at zero-clearance.
- When adjusting the screws close to the end of the way, gradually stroke the table and ensure that the roller cage is positioned at the adjusting screw.
- Using the above process, the internal clearance becomes zero or minimal preload, but the preload amount is not uniform along the way length. Therefore, repeat the same process and tighten all adjusting screws uniformly to the recorded tightening torque.

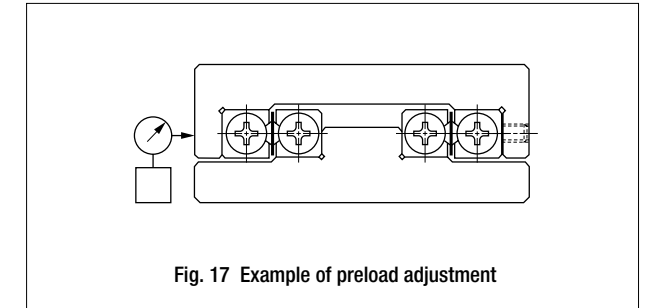

Fig. 17 Example of preload adjustment

**7 Final fixing of way at adjusting side**

- The mounting screws have been tightened lightly to a uniform torque. Similar to the adjustment of the preload adjusting screws, temporarily tighten the mounting screws at the adjusting side to a slightly lower tightening torque than the prescribed value. Start from the center screw of the way length and proceed alternately to the left and right.
- When tightening the mounting screws close to the end of the way, gradually stroke the table and ensure that the roller cage is positioned at the mounting screw.
- Finally, tighten all mounting screws at the adjusting side uniformly to the prescribed torque similar to the adjustment of the preload adjusting screws.

**8 Final check (Fig. 18)**

- Stroke the table gradually its full stroke length, ensuring that the stroke is smooth and quiet.
- Check the operating accuracy by measuring the upper and side faces of table with a dial gauge.

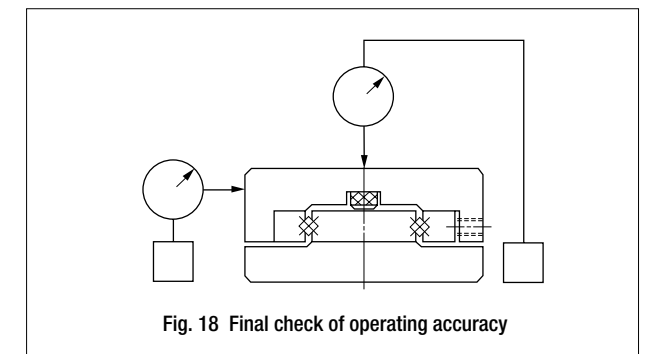

Fig. 18 Final check of operating accuracy

## ● Mounting of CRWM

A general mounting example of CRWM is shown in Fig. 19. The general mounting procedure is as follows.

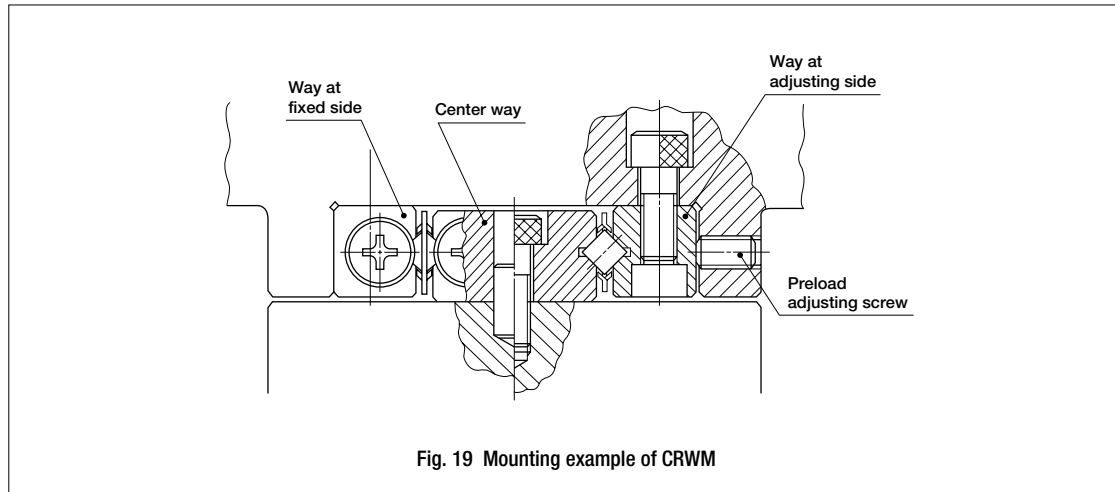

Fig. 19 Mounting example of CRWM

### ① Preparation for mounting

- CRWM is delivered as an individual package containing one center way, two side ways and two roller cages. The ways in each package are not interchangeable with ways in other packages, so do not mix them.
- Separate the end screws or end stoppers and wash the ways with a clean cleaning agent. After cleaning, apply rust preventive oil or lubricating oil.

### ② Cleaning of mounting surfaces on table and bed

- Use the same procedure as that for CRW.

### ③ Mounting of center way (Fig. 20)

- Roughly position the center way to the mounting surface of bed and lightly tighten the mounting screws.
- Temporarily tighten the mounting screws with uniform tightening torque while adjusting the position of the center way by checking the parallelism between the datum surface in the operating direction and the raceways of the center way with a dial gauge.
- Finally, tighten all mounting screws uniformly to the prescribed torque.

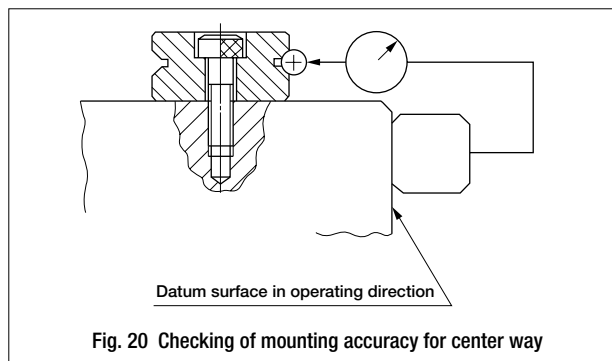

Fig. 20 Checking of mounting accuracy for center way

### ④ Drilling for dowel pin hole (Fig. 21)

- If dowel pins are needed to fix the center way to the bed, drill holes to the bed through the dowel pin holes of the center way while assembling the center way on the bed and locating the drill tool to dowel pin holes near the way ends. The holes for dowel pins in the center way are manufactured to H7 tolerance. Therefore, the holes in bed should have the same tolerance.
- Hole diameters and their tolerances are shown in the dimension tables.
- Remove any drilling chips and, if necessary, wash again the table assembly. If the table assembly of the machine is large, first disassemble the center way. Then wash the table and the center way individually before re-assembly.
- Insert dowel pins and check the parallelism between the datum surface in the operating direction and the raceways of the center way.

### ⑤ Mounting of way at table side

- Use the same procedure as that for CRW.

### ⑥ Assembling of table and bed

- Use the same procedure as that for CRW.

### ⑦ Preload adjustment

- Use the same procedure as that for CRW.

### ⑧ Final fixing of way at adjusting side

- Use the same procedure as that for CRW.

### ⑨ Final check

- Use the same procedure as that for CRW.

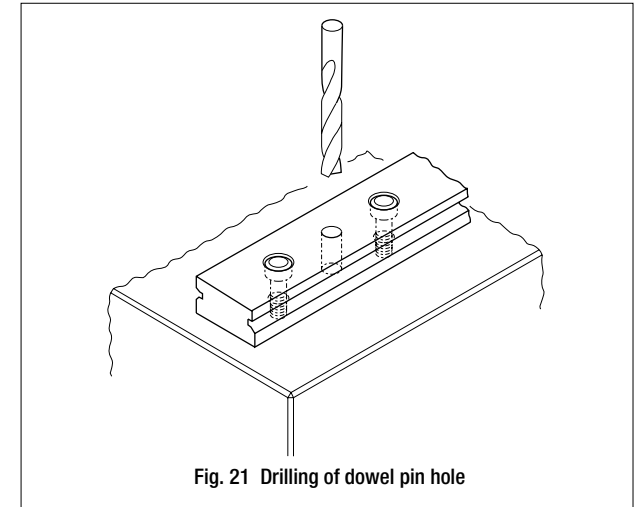

Fig. 21 Drilling of dowel pin hole

## ● Match marks of CRWM

Ways of CRWM have match marks so that they can be assembled with the best operating results. When assembling ways, the match marks on the way end should be positioned at the same end as shown in Fig. 22.

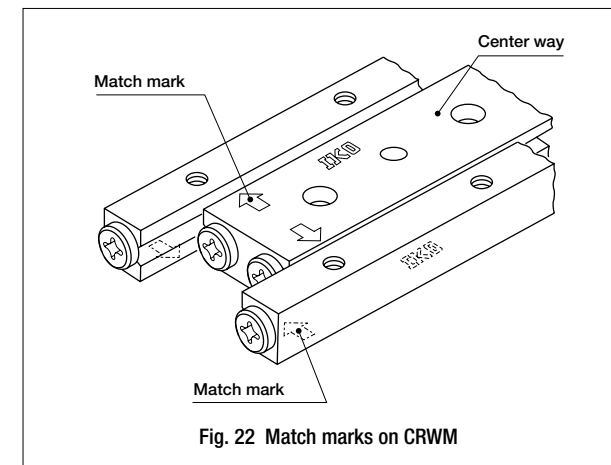
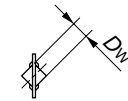
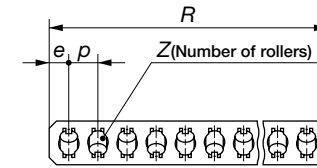
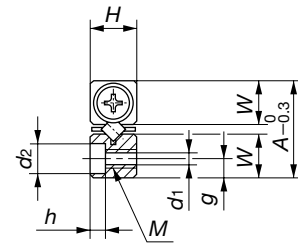
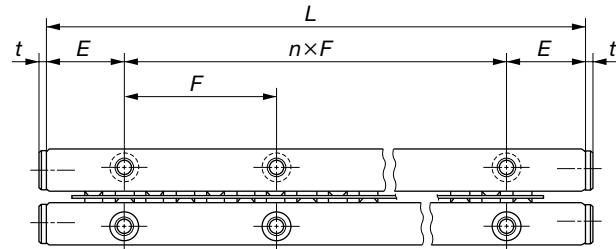

Fig. 22 Match marks on CRWM

Standard type  
**CRW**  
**CRW ...SL** (Stainless steel made)



Model number	Mass (Ref.)		Boundary dimensions				Dimensions of roller cage		Basic dynamic load rating Cu <sup>(3)</sup> N	Basic static load rating C <sub>0u</sub> <sup>(3)</sup> N	Allowable load Fu <sup>(3)</sup> N
	Way <sup>(1)</sup> kg/m	Roller cage <sup>(2)</sup> g	A	H	L (n×F)	E	Dw	R			
CRW 1- 20	0.12	0.38	8.5	4	20 ( 1×10)	5	1.5	16.5	125	120	39.8
CRW 1- 20 SL											
CRW 1- 30					30 ( 2×10)			25.5			
CRW 1- 30 SL											
CRW 1- 40					40 ( 3×10)			31.5			
CRW 1- 40 SL											
CRW 1- 50					50 ( 4×10)			37.5			
CRW 1- 50 SL											
CRW 1- 60					60 ( 5×10)			43.5			
CRW 1- 60 SL											
CRW 1- 70					70 ( 6×10)			52.5			
CRW 1- 70 SL											
CRW 1- 80	80 ( 7×10)	61.5									
CRW 1- 80 SL											

Note<sup>(1)</sup> : This value shows mass per one meter for individual way.  
<sup>(2)</sup> : This value shows mass of one roller cage in which ten rollers are incorporated.  
<sup>(3)</sup> : This value shows load per one roller.

Nominal dimensions mm										Basic dynamic load rating Cu <sup>(3)</sup> N	Basic static load rating C <sub>0u</sub> <sup>(3)</sup> N	Allowable load Fu <sup>(3)</sup> N
Z	p	e	W	g	M	d <sub>1</sub>	d <sub>2</sub>	h	t			
5												
8												
10												
12	3	2.25	3.9	1.8	M2	1.65	3	1.4	1.7	125	120	39.8
14												
17												
20												

Standard type  
**CRW**  
**CRW ...SL** (Stainless steel made)

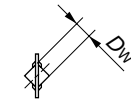
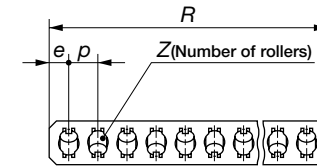
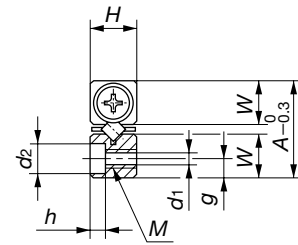
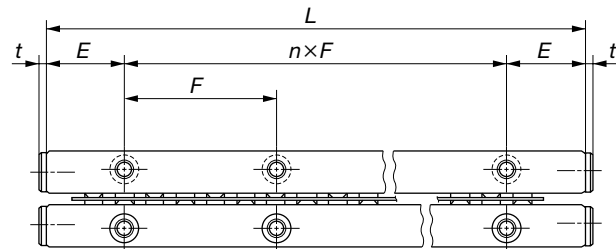

Model number	Mass (Ref.)		Boundary dimensions				Dimensions of roller cage		Basic dynamic load rating Cu <sup>(3)</sup> N	Basic static load rating C0u <sup>(3)</sup> N	Allowable load Fu <sup>(3)</sup> N
	Way <sup>(1)</sup> kg/m	Roller cage <sup>(2)</sup> g	A	H	L (n×F)	E	Dw	R			
CRW 2- 30	0.24	0.98	12	6	30 ( 1×15)	7.5	2	29.6	293	294	97.9
CRW 2- 30 SL											
CRW 2- 45					45 ( 2×15)			41.6			
CRW 2- 45 SL											
CRW 2- 60					60 ( 3×15)			53.6			
CRW 2- 60 SL											
CRW 2- 75					75 ( 4×15)			65.6			
CRW 2- 75 SL											
CRW 2- 90					90 ( 5×15)			77.6			
CRW 2- 90 SL											
CRW 2-105					105 ( 6×15)			89.6			
CRW 2-105 SL											
CRW 2-120					120 ( 7×15)			101.6			
CRW 2-120 SL											
CRW 2-135					135 ( 8×15)			113.6			
CRW 2-135 SL											
CRW 2-150					150 ( 9×15)			125.6			
CRW 2-150 SL											
CRW 2-165	165 (10×15)	137.6									
CRW 2-165 SL											
CRW 2-180	180 (11×15)	149.6									
CRW 2-180 SL											

Z	Nominal dimensions mm									Basic dynamic load rating Cu <sup>(3)</sup> N	Basic static load rating C0u <sup>(3)</sup> N	Allowable load Fu <sup>(3)</sup> N
	p	e	W	g	M	d1	d2	h	t			
7										293	294	97.9
10												
13												
16												
19												
22	4	2.8	5.5	2.5	M3	2.55	4.4	2	1.5			
25												
28												
31												
34												
37												

Note<sup>(1)</sup> : This value shows mass per one meter for individual way.  
<sup>(2)</sup> : This value shows mass of one roller cage in which ten rollers are incorporated.  
<sup>(3)</sup> : This value shows load per one roller.



Standard type  
**CRW**  
**CRW ...SL** (Stainless steel made)

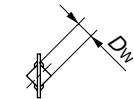
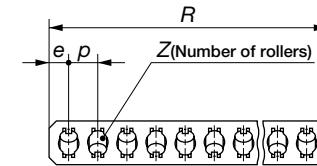
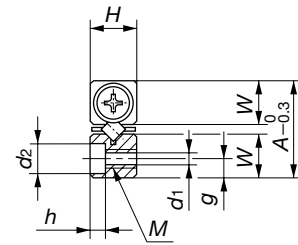
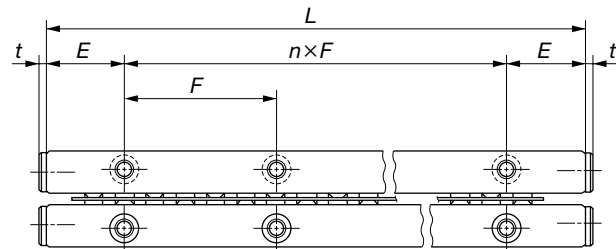

Model number	Mass (Ref.)		Boundary dimensions				Dimensions of roller cage						
	Way <sup>(1)</sup> kg/m	Roller cage <sup>(2)</sup> g	A	H	L (n×F)	E	Dw	R					
CRW 3- 50	0.50	2.96	18	8	50 ( 1×25)	12.5	3	42					
CRW 3- 50 SL					75 ( 2×25)			62					
CRW 3- 75					100 ( 3×25)			82					
CRW 3- 75 SL					125 ( 4×25)			102					
CRW 3-100					150 ( 5×25)			122					
CRW 3-100 SL					175 ( 6×25)			142					
CRW 3-125					200 ( 7×25)			162					
CRW 3-125 SL					225 ( 8×25)			182					
CRW 3-150					250 ( 9×25)			202					
CRW 3-150 SL					275 (10×25)			222					
CRW 3-175					300 (11×25)			242					
CRW 3-175 SL													
CRW 3-200													
CRW 3-200 SL													
CRW 3-225													
CRW 3-225 SL													
CRW 3-250													
CRW 3-250 SL													
CRW 3-275													
CRW 3-275 SL													
CRW 3-300													
CRW 3-300 SL													

Z	Nominal dimensions mm										Basic dynamic load rating Cu <sup>(3)</sup> N	Basic static load rating C0u <sup>(3)</sup> N	Allowable load Fu <sup>(3)</sup> N	
	p	e	W	g	M	d1	d2	h	t					
8														
12														
16														
20														
24														
28	5	3.5	8.3	3.5	M4	3.3	6	3.1	2		638	609	203	
32														
36														
40														
44														
48														

Note<sup>(1)</sup> : This value shows mass per one meter for individual way.  
<sup>(2)</sup> : This value shows mass of one roller cage in which ten rollers are incorporated.  
<sup>(3)</sup> : This value shows load per one roller.

Standard type  
**CRW**  
**CRW ...SL** (Stainless steel made)

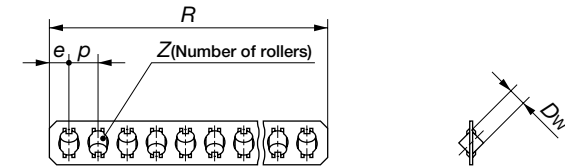
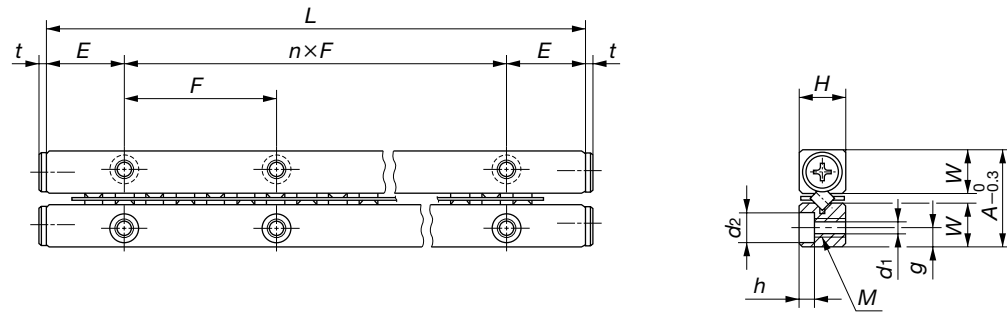

Model number	Mass (Ref.)		Boundary dimensions				Dimensions of roller cage		Basic dynamic load rating Cu <sup>(3)</sup> N	Basic static load rating C0u <sup>(3)</sup> N	Allowable load Fu <sup>(3)</sup> N
	Way <sup>(1)</sup> kg/m	Roller cage <sup>(2)</sup> g	A	H	L (n x F)	E	Dw	R			
CRW 4- 80	0.82	6.91	22	11	80 ( 1 x 40)	20	4	73	1 230	1 180	392
CRW 4- 80 SL					80 ( 1 x 40)			73			
CRW 4-120					120 ( 2 x 40)			101			
CRW 4-120 SL					120 ( 2 x 40)			101			
CRW 4-160					160 ( 3 x 40)			136			
CRW 4-160 SL					160 ( 3 x 40)			136			
CRW 4-200					200 ( 4 x 40)			164			
CRW 4-200 SL					200 ( 4 x 40)			164			
CRW 4-240					240 ( 5 x 40)			199			
CRW 4-240 SL					240 ( 5 x 40)			199			
CRW 4-280					280 ( 6 x 40)			227			
CRW 4-280 SL					280 ( 6 x 40)			227			
CRW 4-320					320 ( 7 x 40)			262			
CRW 4-320 SL					320 ( 7 x 40)			262			
CRW 4-360					360 ( 8 x 40)			297			
CRW 4-360 SL					360 ( 8 x 40)			297			
CRW 4-400					400 ( 9 x 40)			325			
CRW 4-400 SL					400 ( 9 x 40)			325			
CRW 4-440	440 (10 x 40)	360									
CRW 4-440 SL	440 (10 x 40)	360									
CRW 4-480	480 (11 x 40)	388									
CRW 4-480 SL	480 (11 x 40)	388									

Z	Nominal dimensions mm										Basic dynamic load rating Cu <sup>(3)</sup> N	Basic static load rating C0u <sup>(3)</sup> N	Allowable load Fu <sup>(3)</sup> N	
	p	e	W	g	M	d1	d2	h	t	R				
10														
14														
19														
23														
28														
32	7	5	10	4.5	M5	4.3	7.5	4.1	2					
37														
42														
46														
51														
55														

Note<sup>(1)</sup> : This value shows mass per one meter for individual way.  
<sup>(2)</sup> : This value shows mass of one roller cage in which ten rollers are incorporated.  
<sup>(3)</sup> : This value shows load per one roller.

Standard type  
**CRW**  
**CRW ...SL** (Stainless steel made)

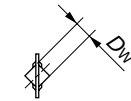
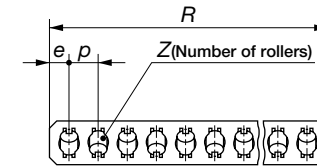
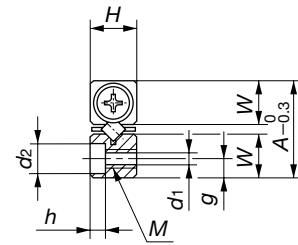
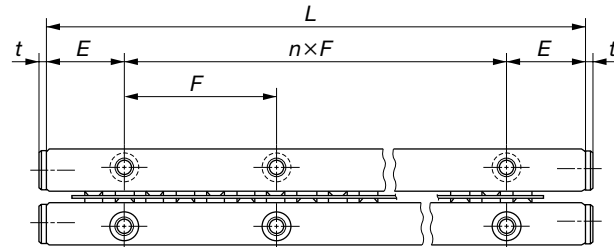

Model number	Mass (Ref.)		Boundary dimensions				Dimensions of roller cage		
	Way <sup>(1)</sup> kg/m	Roller cage <sup>(2)</sup> g	A	H	L (n×F)	E	Dw	R	
CRW 6-100	1.57	20.3	31	15	100 ( 1×50)	25	6	84	
CRW 6-100 SL									
CRW 6-150									
CRW 6-150 SL									
CRW 6-200									
CRW 6-200 SL									
CRW 6-250									
CRW 6-250 SL									
CRW 6-300									
CRW 6-300 SL									
CRW 6-350									
CRW 6-350 SL									
CRW 6-400									
CRW 6-400 SL									
CRW 6-450									
CRW 6-450 SL									
CRW 6-500									
CRW 6-500 SL									
CRW 6-550									
CRW 6-550 SL									
CRW 6-600									
CRW 6-600 SL									

Z	Nominal dimensions mm									Basic dynamic load rating Cu <sup>(3)</sup> N	Basic static load rating C0u <sup>(3)</sup> N	Allowable load Fu <sup>(3)</sup> N
	p	e	W	g	M	d1	d2	h	t			
9										2 570	2 310	769
14												
18												
23												
27												
31	9	6	14	6	M6	5.3	9.5	5.2	3			
36												
40												
45												
49												
54												

Note<sup>(1)</sup> : This value shows mass per one meter for individual way.  
<sup>(2)</sup> : This value shows mass of one roller cage in which ten rollers are incorporated.  
<sup>(3)</sup> : This value shows load per one roller.

## Standard type CRW

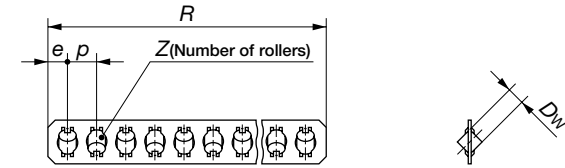
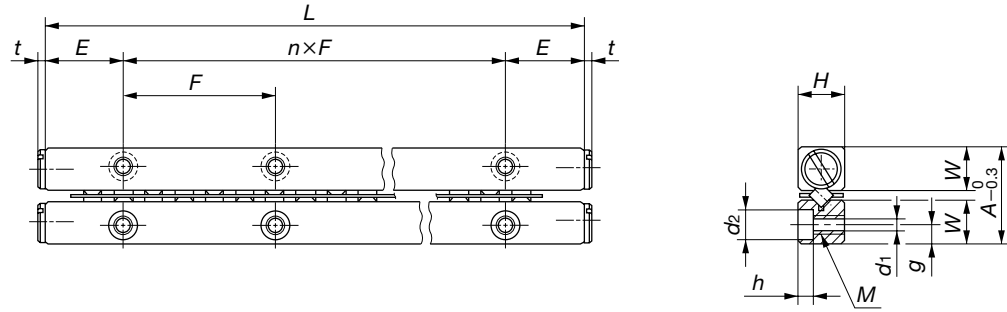

Model number	Mass (Ref.)		Boundary dimensions				Dimensions of roller cage		Basic dynamic load rating Cu <sup>(3)</sup> N	Basic static load rating CoU <sup>(3)</sup> N	Allowable load Fu <sup>(3)</sup> N
	Way <sup>(1)</sup> kg/m	Roller cage <sup>(2)</sup> g	A	H	L (n×F)	E	Dw	R			
CRW 9- 200	3.3	64.8	44	22	200 ( 1×100)	50	9	173	7 190	6 600	2 200
CRW 9- 300					300 ( 2×100)			257			
CRW 9- 400					400 ( 3×100)			327			
CRW 9- 500					500 ( 4×100)			411			
CRW 9- 600					600 ( 5×100)			495			
CRW 9- 700					700 ( 6×100)			565			
CRW 9- 800					800 ( 7×100)			649			
CRW 9- 900					900 ( 8×100)			733			
CRW 9-1000					1 000 ( 9×100)			817			
CRW 9-1100					1 100 (10×100)			887			
CRW 9-1200					1 200 (11×100)			971			
CRW 12- 200	5.57	146	58	28	200 ( 1×100)	50	12	168	14 700	13 600	4 540
CRW 12- 300					300 ( 2×100)			258			
CRW 12- 400					400 ( 3×100)			330			
CRW 12- 500					500 ( 4×100)			420			
CRW 12- 600					600 ( 5×100)			492			
CRW 12- 700					700 ( 6×100)			564			
CRW 12- 800					800 ( 7×100)			654			
CRW 12- 900					900 ( 8×100)			726			
CRW 12-1000					1 000 ( 9×100)			816			
CRW 12-1100					1 100 (10×100)			888			
CRW 12-1200					1 200 (11×100)			978			

Nominal dimensions mm										Basic dynamic load rating Cu <sup>(3)</sup> N	Basic static load rating CoU <sup>(3)</sup> N	Allowable load Fu <sup>(3)</sup> N
Z	p	e	W	g	M	d1	d2	h	t			
12	14	9.5	20.2	9	M 8	6.8	10.5	6.2	3	7 190	6 600	2 200
18												
23												
29												
35												
40												
46												
52												
58												
63												
69												
9	18	12	26.9	12	M10	8.5	13.5	8.2	3	14 700	13 600	4 540
14												
18												
23												
27												
31												
36												
40												
45												
49												
54												

Note<sup>(1)</sup> : This value shows mass per one meter for individual way.  
<sup>(2)</sup> : This value shows mass per one roller cage in which ten rollers are incorporated.  
<sup>(3)</sup> : This value shows load per one roller.

## Standard type CRW

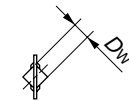
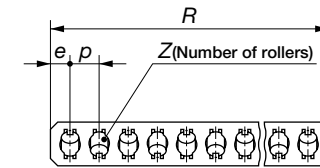
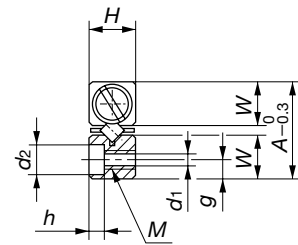
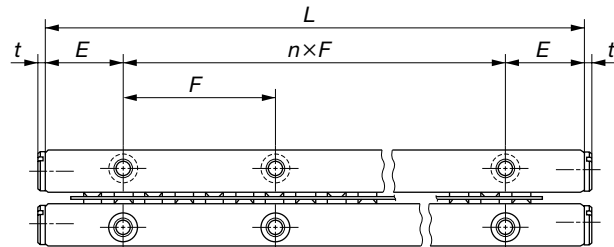

Model number	Mass (Ref.)		Boundary dimensions				Dimensions of roller cage		Basic dynamic load rating Cu <sup>(3)</sup> N	Basic static load rating CoU <sup>(3)</sup> N	Allowable load Fu <sup>(3)</sup> N
	Way <sup>(1)</sup> kg/m	Roller cage <sup>(2)</sup> g	A	H	L (n×F)	E	Dw	R			
CRW 15- 300	8.75	273	71	36	300 ( 2×100)	50	15	261	23 800	21 900	7 300
CRW 15- 400					400 ( 3×100)			330			
CRW 15- 500					500 ( 4×100)			422			
CRW 15- 600					600 ( 5×100)			491			
CRW 15- 700					700 ( 6×100)			583			
CRW 15- 800					800 ( 7×100)			652			
CRW 15- 900					900 ( 8×100)			744			
CRW 15-1000					1 000 ( 9×100)			813			
CRW 15-1100					1 100 (10×100)			905			
CRW 15-1200					1 200 (11×100)			974			
CRW 18- 300					11.3			447			
CRW 18- 400	400 ( 3×100)	346									
CRW 18- 500	500 ( 4×100)	430									
CRW 18- 600	600 ( 5×100)	514									
CRW 18- 700	700 ( 6×100)	570									
CRW 18- 800	800 ( 7×100)	654									
CRW 18- 900	900 ( 8×100)	738									
CRW 18-1000	1 000 ( 9×100)	822									
CRW 18-1100	1 100 (10×100)	906									
CRW 18-1200	1 200 (11×100)	990									

Note<sup>(1)</sup>: This value shows mass per one meter for individual way.  
<sup>(2)</sup>: This value shows mass of one roller cage in which ten rollers are incorporated.  
<sup>(3)</sup>: This value shows load per one roller.

Nominal dimensions mm										Basic dynamic load rating Cu <sup>(3)</sup> N	Basic static load rating CoU <sup>(3)</sup> N	Allowable load Fu <sup>(3)</sup> N
Z	p	e	W	g	M	d1	d2	h	t			
11	23	15.5	33	14	M12	10.5	16.5	10.2	5	23 800	21 900	7 300
14												
18												
21												
25												
28												
32												
35												
39												
42												
9												
12												
15												
18												
20												
23												
26												
29												
32												
35												

## Standard type CRW

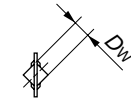
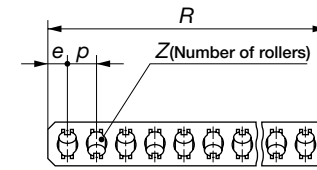
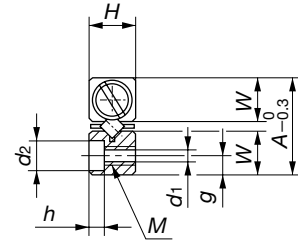
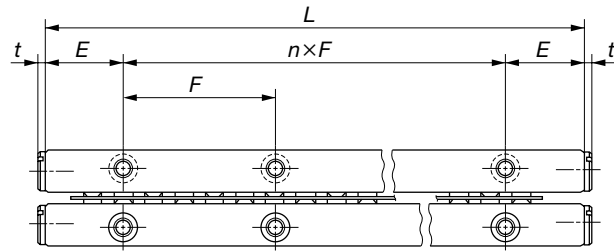

Model number	Mass (Ref.)		Boundary dimensions		Dimensions of roller cage			
	Way <sup>(1)</sup> kg/m	Roller cage <sup>(2)</sup> g	A	H	L (n×F)	E	Dw	R
CRW 24- 400	20.6	1 060	110	55	400 ( 3×100)	50	24	336
CRW 24- 500					500 ( 4×100)			408
CRW 24- 600					600 ( 5×100)			516
CRW 24- 700					700 ( 6×100)			588
CRW 24- 800					800 ( 7×100)			660
CRW 24- 900					900 ( 8×100)			732
CRW 24-1000					1 000 ( 9×100)			840
CRW 24-1100					1 100 (10×100)			912
CRW 24-1200					1 200 (11×100)			984

Note<sup>(1)</sup> : This value shows mass per one meter for individual way.  
<sup>(2)</sup> : This value shows mass of one roller cage in which ten rollers are incorporated.  
<sup>(3)</sup> : This value shows load per one roller.

Nominal dimensions mm										Basic dynamic load rating Cu <sup>(3)</sup> N	Basic static load rating CoU <sup>(3)</sup> N	Allowable load Fu <sup>(3)</sup> N
Z	p	e	W	g	M	d1	d2	h	t			
9	36	24	51.5	24	M16	14.5	22.5	14.2	5	69 600	63 500	21 200
11												
14												
16												
18												
20												
23												
25												
27												

**Module type  
CRWM**

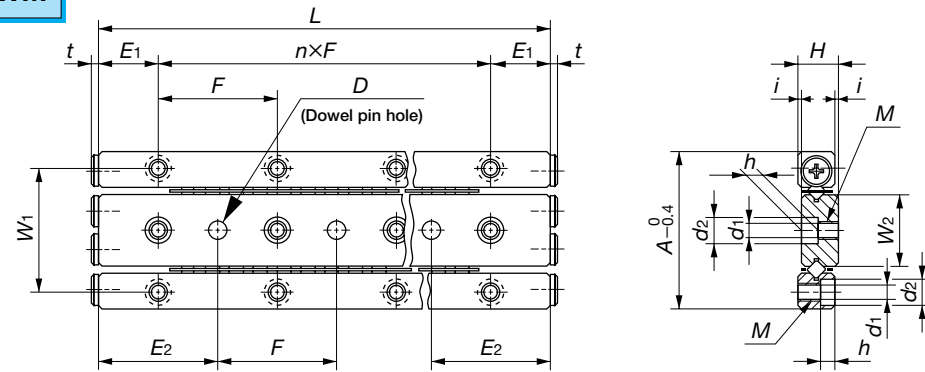

Model number	Mass (Ref.)		Boundary dimensions		Dimensions of roller cage					Basic dynamic load rating Cu <sup>(3)</sup> N	Basic static load rating C <sub>0</sub> u <sup>(3)</sup> N	Allowable load Fu <sup>(3)</sup> N		
	Way <sup>(1)</sup> kg/m	Roller cage <sup>(2)</sup> g	A	H	L (n×F)	i	Dw	R	Z					
CRWM 1- 20	0.49	0.38	17	4.5	20 ( 1×10)	0.5	1.5	16.5	5	+0.010 0	1.7	125	120	39.8
CRWM 1- 30					30 ( 2×10)			25.5	8					
CRWM 1- 40					40 ( 3×10)			31.5	10					
CRWM 1- 50					50 ( 4×10)			37.5	12					
CRWM 1- 60					60 ( 5×10)			43.5	14					
CRWM 1- 70					70 ( 6×10)			52.5	17					
CRWM 1- 80					80 ( 7×10)			61.5	20					
CRWM 2- 30	0.99	0.98	24	6.5	30 ( 1×15)	0.5	2	29.6	7	+0.010 0	1.5	293	294	97.9
CRWM 2- 45					45 ( 2×15)			41.6	10					
CRWM 2- 60					60 ( 3×15)			53.6	13					
CRWM 2- 75					75 ( 4×15)			65.6	16					
CRWM 2- 90					90 ( 5×15)			77.6	19					
CRWM 2-105					105 ( 6×15)			89.6	22					
CRWM 2-120					120 ( 7×15)			101.6	25					
CRWM 2-135					135 ( 8×15)			113.6	28					
CRWM 2-150					150 ( 9×15)			125.6	31					
CRWM 2-165					165 (10×15)			137.6	34					
CRWM 2-180					180 (11×15)			149.6	37					

Note(1) : This value shows mass per one set of ways (one center way and two side ways) per one meter.  
 (2) : This value shows mass of one roller cage in which ten rollers are incorporated.  
 (3) : This value shows load per one roller.

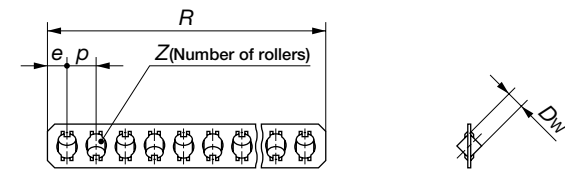

Nominal dimensions and tolerances mm														Basic dynamic load rating Cu <sup>(3)</sup> N	Basic static load rating C <sub>0</sub> u <sup>(3)</sup> N	Allowable load Fu <sup>(3)</sup> N
Mounting dimensions		Boundary dimensions														
p	e	W <sub>1</sub>	W <sub>2</sub>	E <sub>1</sub>	E <sub>2</sub>	M	d <sub>1</sub>	d <sub>2</sub>	h	D	Tolerance	t				
3	2.25	13.4	7.8	5	10	M2	1.65	3	1.4	2	+0.010 0	1.7	125	120	39.8	
4	2.8	19	11	7.5	15	M3	2.55	4.4	2	3	+0.010 0	1.5	293	294	97.9	

**Module type  
CRWM**

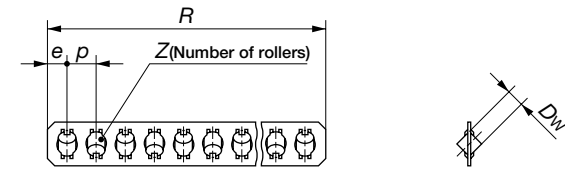
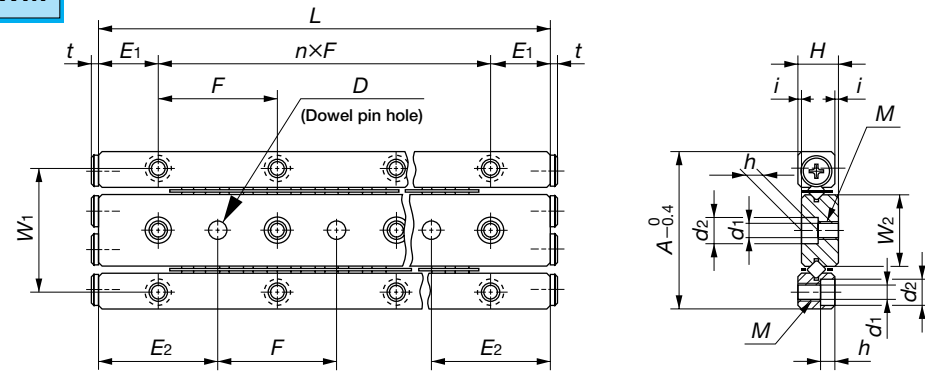

Model number	Mass (Ref.)		Boundary dimensions					Dimensions of roller cage		
	Way <sup>(1)</sup> kg/m	Roller cage <sup>(2)</sup> g	A	H	L (n×F)	i	Dw	R	Z	
CRWM 3- 50	1.99	2.96	36	8.5	50 ( 1×25)	0.5	3	42	8	
CRWM 3- 75					75 ( 2×25)			62	12	
CRWM 3-100					100 ( 3×25)			82	16	
CRWM 3-125					125 ( 4×25)			102	20	
CRWM 3-150					150 ( 5×25)			122	24	
CRWM 3-175					175 ( 6×25)			142	28	
CRWM 3-200					200 ( 7×25)			162	32	
CRWM 3-225					225 ( 8×25)			182	36	
CRWM 3-250					250 ( 9×25)			202	40	
CRWM 3-275					275 (10×25)			222	44	
CRWM 3-300					300 (11×25)			242	48	
CRWM 4- 80	3.28	6.91	44	11.5	80 ( 1×40)	0.5	4	73	10	
CRWM 4-120					120 ( 2×40)			101	14	
CRWM 4-160					160 ( 3×40)			136	19	
CRWM 4-200					200 ( 4×40)			164	23	
CRWM 4-240					240 ( 5×40)			199	28	
CRWM 4-280					280 ( 6×40)			227	32	
CRWM 4-320					320 ( 7×40)			262	37	
CRWM 4-360					360 ( 8×40)			297	42	
CRWM 4-400					400 ( 9×40)			325	46	
CRWM 4-440					440 (10×40)			360	51	
CRWM 4-480	480 (11×40)	388	55							

Nominal dimensions and tolerances mm														Basic dynamic load rating Cu <sup>(3)</sup> N	Basic static load rating CoU <sup>(3)</sup> N	Allowable load Fu <sup>(3)</sup> N
p	e	W1	W2	E1	E2	M	d1	d2	h	D	Tolerance	t				
5	3.5	29	16.6	12.5	25	M4	3.3	6	3.1	4	+0.012 0	2	638	609	203	
7	5	35	20	20	40	M5	4.3	7.5	4.1	5	+0.012 0	2	1 230	1 180	392	

Note<sup>(1)</sup> : This value shows mass per one set of ways (one center way and two side ways) per one meter.  
<sup>(2)</sup> : This value shows mass of one roller cage in which ten rollers are incorporated.  
<sup>(3)</sup> : This value shows load per one roller.



**Module type  
CRWM**

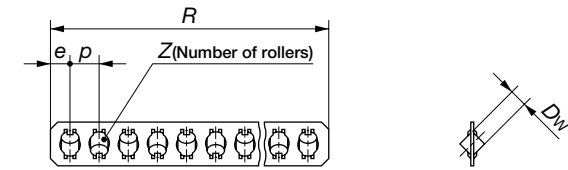
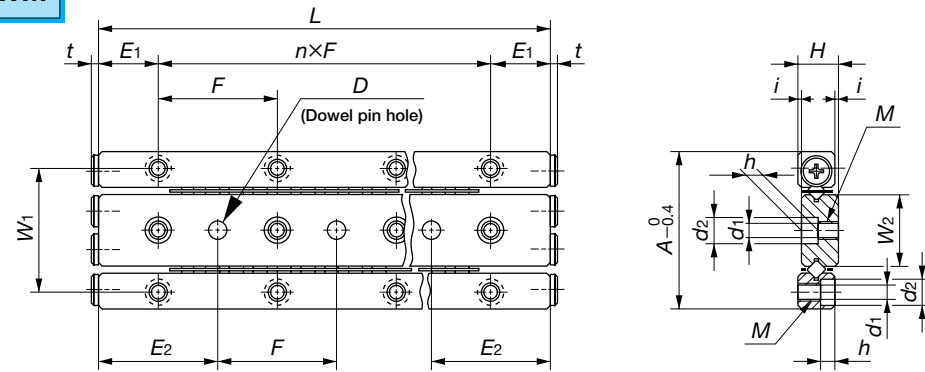

Model number	Mass (Ref.)		Boundary dimensions				Dimensions of roller cage			
	Way <sup>(1)</sup> kg/m	Roller cage <sup>(2)</sup> g	A	H	L (n×F)	i	Dw	R	Z	
CRWM 4- 80A	3.96	6.91	48	12.5	80 ( 1×40)	0.5	4	73	10	
CRWM 4-120A					120 ( 2×40)			101	14	
CRWM 4-160A					160 ( 3×40)			136	19	
CRWM 4-200A					200 ( 4×40)			164	23	
CRWM 4-240A					240 ( 5×40)			199	28	
CRWM 4-280A					280 ( 6×40)			227	32	
CRWM 4-320A					320 ( 7×40)			262	37	
CRWM 4-360A					360 ( 8×40)			297	42	
CRWM 4-400A					400 ( 9×40)			325	46	
CRWM 4-440A					440 (10×40)			360	51	
CRWM 4-480A	480 (11×40)	388	55							

Note<sup>(1)</sup> : This value shows mass per one set of ways (one center way and two side ways) per one meter.  
<sup>(2)</sup> : This value shows mass of one roller cage in which ten rollers are incorporated.  
<sup>(3)</sup> : This value shows load per one roller.

Nominal dimensions and tolerances mm														Basic dynamic load rating Cu <sup>(3)</sup> N	Basic static load rating CoU <sup>(3)</sup> N	Allowable load Fu <sup>(3)</sup> N
p	e	W1	W2	E1	E2	M	d1	d2	h	D	Tolerance	t				
7	5	38	22	20	40	M5	4.3	8	4.1	5	+0.012 0	2	1 230	1 180	392	

# Crossed Roller Way Unit

## CRWU

**IKO** Crossed Roller Way Unit is a linear motion rolling guide unit for limited stroke linear motion, incorporating **IKO** Crossed Roller Way CRW in a table and bed of high rigidity which are finished by grinding. Elastic deformation under load is small in all directions and very smooth linear motion with high rigidity is obtained. Wide variations in size are available for selections suitable for each application.

### High accuracy

A one-piece center way is mounted on a bed of simple configuration which avoids any potential errors from machining and assembled with side ways mounted on a table, achieving linear motion of stable high accuracy.

### High rigidity

Integrated design is applied to component parts as well as the table and bed to provide maximum rigidity. The assembled unit consequently demonstrates low elastic deformation against loads in any direction and performs with very high rigidity.

### Smooth operation

A one-piece center way which avoids any potential processing and mounting errors is combined with super precise cylindrical rollers. So very smooth linear motion free from stick-slip can be obtained.

### A variety of available models and sizes

Crossed Roller Way Unit is available in three types. In addition, many different sizes in each type are provided to meet diverse dimensional requirements of machines and equipment.

### Easy mounting

Mounting surfaces of the table and bed are precisely finished by grinding. Female threads in the table and counterbored mounting holes in the bed are prepared for easy assembling. Crossed Roller Way Unit is delivered from the factory with a finely adjusted preload in order to maintain high operating accuracy, rigidity and long life. Therefore, by assembling Crossed Roller Way Unit into machines or equipment, a precise and durable linear motion mechanism can be easily obtained.

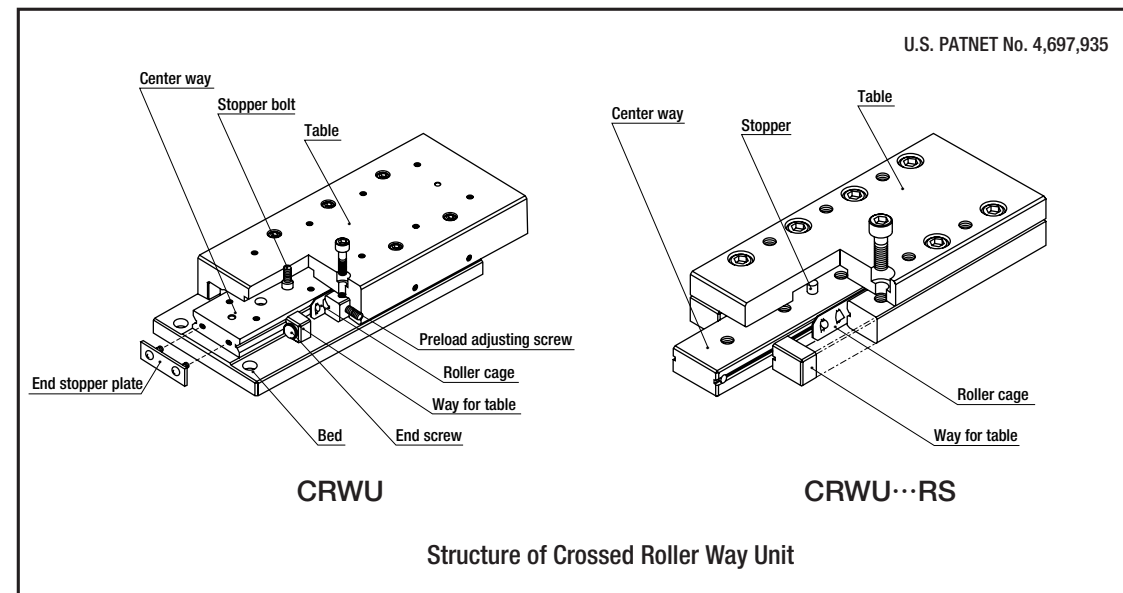

## Crossed Roller Way Unit series

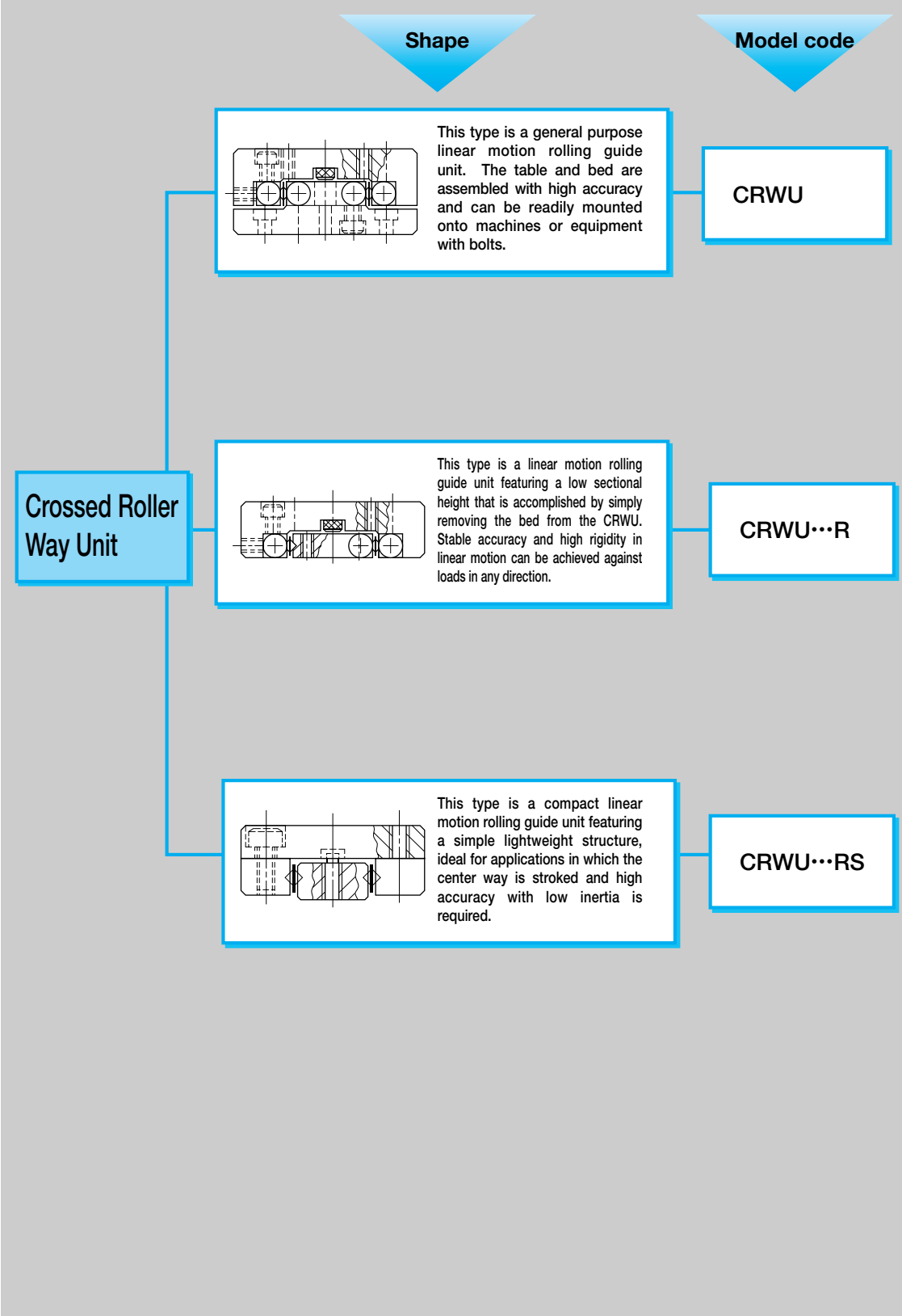

CRWU, CRWU...R, CRWU...RS

## ● Identification number and specification

The specification of Crossed Roller Way Unit is indicated by the identification number, consisting of a model code and a size. An example is shown below.

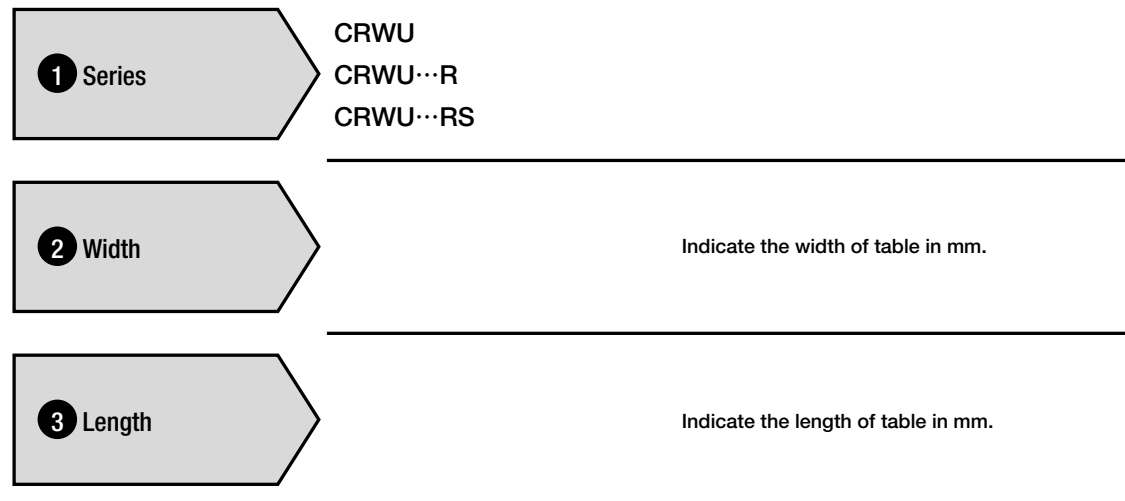
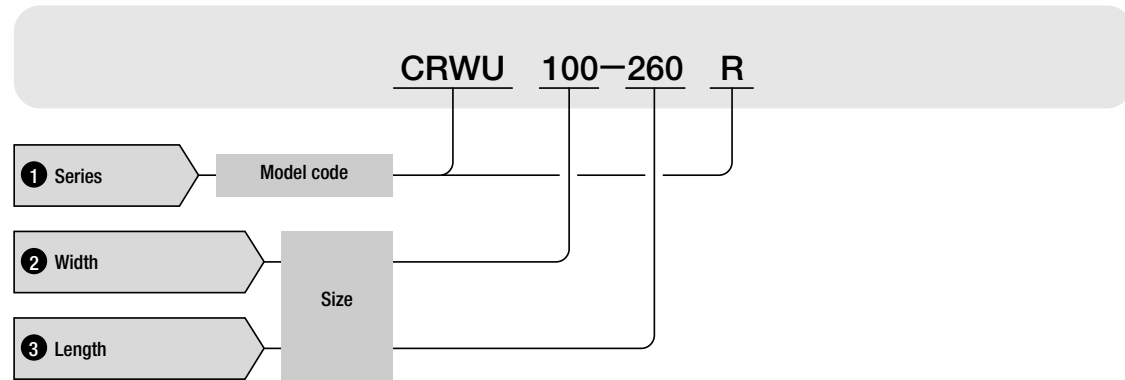

## Load Rating and Allowable Load

Summarized descriptions of load ratings of Crossed Roller Way Unit are given below. For details of load rating definitions and load calculations, see "General description". The load ratings for upward and lateral loads of Crossed Roller Way Unit are the same as those for downward load.

### ● Basic dynamic load rating $C$

The basic dynamic load rating is defined as the constant load both in direction and magnitude under which a group of identical Crossed Roller Way Units are individually operated and 90% of the units in the group can travel  $100 \times 10^3$  meters free from material damage due to rolling contact fatigue.

### ● Basic static load rating $C_0$

The basic static load rating is defined as the static load that gives a prescribed constant contact stress at the center of the contact area between the rolling element and raceway receiving the maximum load.

### ● Allowable load $F$

The allowable load is a load under which the sum of elastic deformations of the rolling element and the raceway in the contact area subjected to the maximum contact stress is small enough to guarantee accuracy and smooth rolling movement. Therefore, when very smooth and highly accurate linear motion is required, make sure that the applied load on Crossed Roller Way Unit is well within the allowable load value.

### ● Static moment rating $T_0$

The static moment rating is defined as the static moment load that gives a prescribed constant contact stress at the center of the contact area between the rolling element and raceway receiving the maximum load when a moment is loaded.

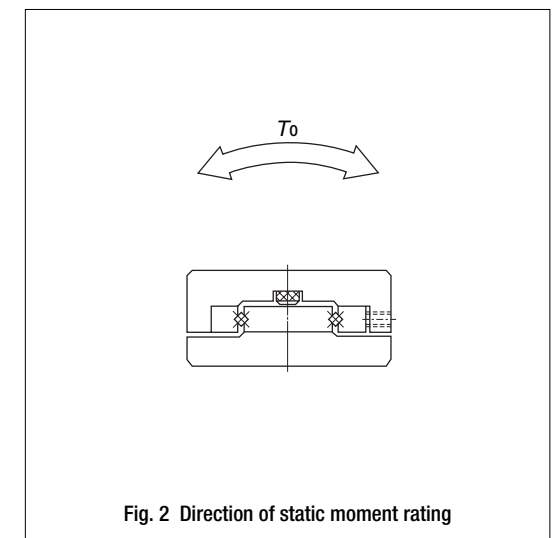
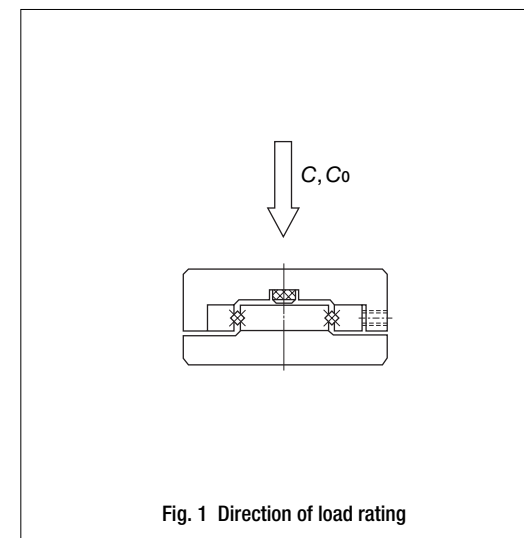

## Accuracy

The accuracy of Crossed Roller Way Unit is shown in Table 1.

Parallelism at table center shows the difference between the maximum and the minimum of table height when the table is stroked.

Parallelism at table side shows the difference between the maximum and the minimum of measured values at the table side (opposite to adjusting side) when the table is stroked.

The standard height tolerance of the unit is  $\pm 0.1$  mm. If several units are used on the same mounting surface and the height of those units require a limited height variation, units with a height variation of less than 0.01 mm among the several units to be used on the same mounting surface can be supplied on request.

If a special accuracy other than those shown in Table 1 is required, consult **I K O**.

Table 1 Accuracy of Crossed Roller Way Unit unit :  $\mu$ m

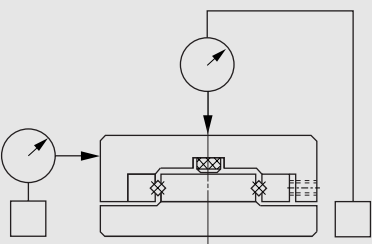

Unit length L mm		Parallelism at table center	Parallelism at table side
over	incl.		
—	50	2	4
50	100	2	5
100	160	3	6
160	310	3	7
310	510	4	8
510	710	4	9
710	—	5	10

## Precautions for Mounting and Use

### 1 Specification

Check whether the specifications of selected Crossed Roller Way Unit meet the requirements for the application of the machine or equipment.

### 2 Handling

Crossed Roller Way Unit is a precision product, so handle it with care.

In Crossed Roller Way Unit, the cage can be shifted from the normal position under an uneven load or irregular and high-speed motion. To correct the cage position, move the table in its full stroke after a certain operating time or reciprocating cycles.

Crossed Roller Way Unit does not contain synthetic resin parts and can be operated at high temperatures. But when the temperature exceeds 100 °C, consult **I K O**.

### 3 Mounting

#### (1) Tightening torque of mounting screws

Tightening torque of mounting screws is shown in Table 2. If vibration or shock is large, or if a moment load is applied, it is recommended to further tighten the screws to 1.3 times the listed values.

#### (2) Mounting dimensions of CRWU...R

In order to avoid interference of the table with the mating mounting surface, carefully check  $H_1$  and  $H$  dimensions shown in the dimension tables and design the height of the mating mounting surface accordingly.

Example of the mating mounting surface of the bed is shown in Table 3.

Table 2 Tightening torque of screws

Screw size	Tightening torque N·m
M2 ×0.4	0.23
M2.5×0.45	0.46
M3 ×0.5	1.4
M4 ×0.7	3.2
M5 ×0.8	6.3
M6 ×1	10.7
M8 ×1.25	25.6

Table 3 Example of mating mounting surface for CRWU...R unit : mm

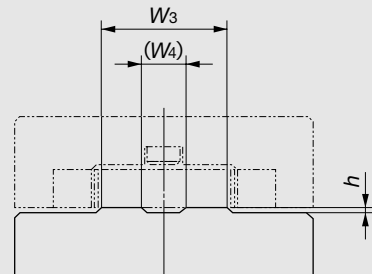

Model number	$h$ (minimum)	$W_3$	$W_4$
CRWU 30 ... R	0.5	13	—
CRWU 40-35R	0.5	18	—
CRWU 40 ... R		13	—
CRWU 60 ... R	0.5	26.5	—
CRWU 80 ... R	0.5	38	16
CRWU 100 ... R	0.5	42	14
CRWU 145 ... R	1.0	68.5	28.5

### 4 Dowel pin hole

In the center way of the CRWU...R, dowel pin holes are prepared. When drilling a dowel pin hole in the bed, drill the hole in the bed through the dowel pin hole in the center way after assembling the center way on the bed. The diameters and tolerances of the center way hole are shown in the dimension tables.

### 5 Readjustment of preload

Preloads of Crossed Roller Way Unit are adjusted to zero clearance or minimal preload at the factory. Crossed Roller Way Unit does not usually require any further adjustment. If preload readjustment of the CRWU or CRWU...R is needed, adjust it according to "Preload adjustment" of the Crossed Roller Way shown on page E-47.

### 6 Operating speed

The operating speed of Crossed Roller Way Unit should not exceed 30 m/min.

## CRWU ※ Mounting dimensions

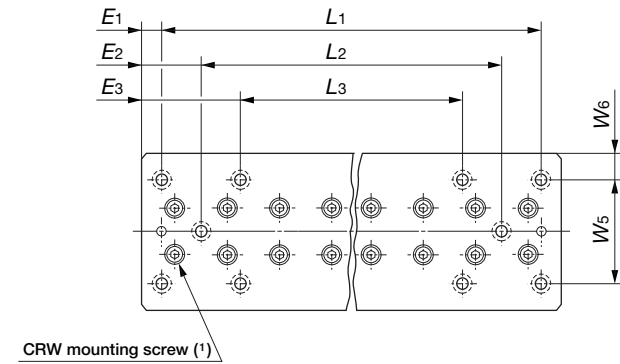
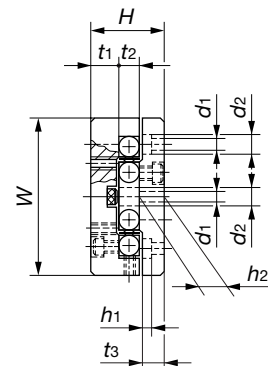
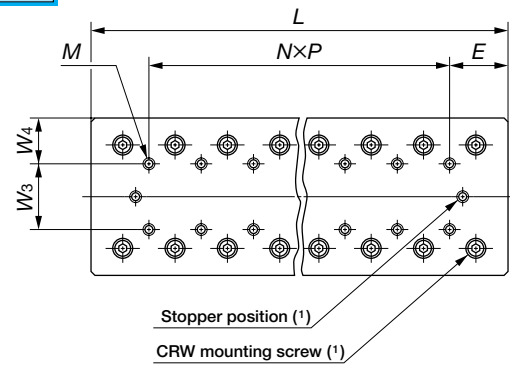

Model number	Mass (Ref.) kg	Boundary dimensions and tolerances mm									Table			
		W	Tolerance	H	Tolerance	L	t <sub>1</sub>	t <sub>2</sub>	t <sub>3</sub>	Maximum stroke length	W <sub>3</sub>	W <sub>4</sub>	N×P	E
CRWU 30- 25	0.09	30	±0.1	17	±0.1	25	7	4	5.5	12	10	10	—	12.5
CRWU 30- 35	0.13					35				18			1×10	
CRWU 30- 45	0.17					45				25			2×10	
CRWU 30- 55	0.20					55				32			3×10	
CRWU 30- 65	0.24					65				40			4×10	
CRWU 30- 75	0.28					75				45			5×10	
CRWU 30- 85	0.32					85				50			6×10	
CRWU 40- 35	0.21	40	±0.1	21	±0.1	35	8	6	6.5	18	15	12.5	—	17.5
CRWU 40- 50	0.30					50	30	1×15						
CRWU 40- 65	0.37					65	40	2×15						
CRWU 40- 80	0.48					80	50	3×15						
CRWU 40- 95	0.54					95	60	4×15						
CRWU 40-110	0.65					110	70	5×15						
CRWU 40-125	0.72					125	80	6×15						
CRWU 60- 55	0.68	60	±0.1	28	±0.1	55	10.5	8	9	30	25	17.5	—	27.5
CRWU 60- 80	1.0					80				45			1×25	
CRWU 60-105	1.3					105				60			2×25	
CRWU 60-130	1.6					130				75			3×25	
CRWU 60-155	1.9					155				90			4×25	
CRWU 60-180	2.2					180				105			5×25	
CRWU 60-205	2.5					205				130			6×25	

Note(1) : This is the mounting position for the stopper or CRW mounting screw.  
For details, see page E-74.

Mounting dimensions mm													Basic dynamic load rating C N	Basic static load rating C <sub>0</sub> N	Allowable load F N	Static moment rating T <sub>0</sub> N·m		
M	W <sub>5</sub>	W <sub>6</sub>	L <sub>1</sub>	E <sub>1</sub>	L <sub>2</sub>	Bed E <sub>2</sub>	L <sub>3</sub>	E <sub>3</sub>	d <sub>1</sub>	d <sub>2</sub>	h <sub>1</sub>	h <sub>2</sub>						
M2	22	4	18	3.5	—	—	28	13.5	2.55	4.1	2.5	6	380	478	159	3.2		
			28										—	—	525	717	239	4.8
			38										—	—	659	956	319	6.5
			48										—	—	786	1 200	398	8.1
			58										38	13.5	906	1 430	478	9.7
			68										45	13.5	1 020	1 670	558	11.3
			78										58	13.5	1 140	1 910	638	12.9
M3	30	5	25	5	—	—	40	20	3.5	6	3.2	6	896	1 180	392	10.6		
			40										—	—	2 710	3 660	1 220	26.5
			55										—	—	2 710	3 660	1 220	26.5
			70										40	20	4 050	6 090	2 030	44.2
			85										55	20	3 400	4 880	1 630	35.3
			100										70	20	4 680	7 310	2 440	53.0
			115										85	20	4 680	7 310	2 440	53.0
M4	40	10	35	10	—	—	—	—	4.5	7.5	4.5	9.5	2 710	3 660	1 220	51.2		
			60										—	—	4 050	6 090	2 030	85.3
			85										—	—	5 270	8 530	2 840	119
			110										—	—	5 860	9 750	3 250	137
			135										85	35	6 970	12 200	4 060	171
			160										110	35	8 040	14 600	4 880	205
			185										135	35	8 550	15 800	5 280	222

## CRWU ※ Mounting dimensions

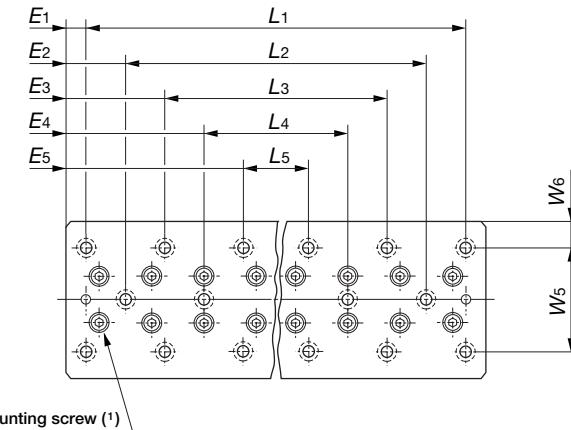
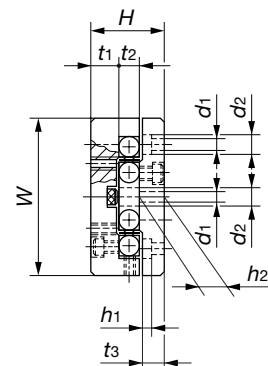
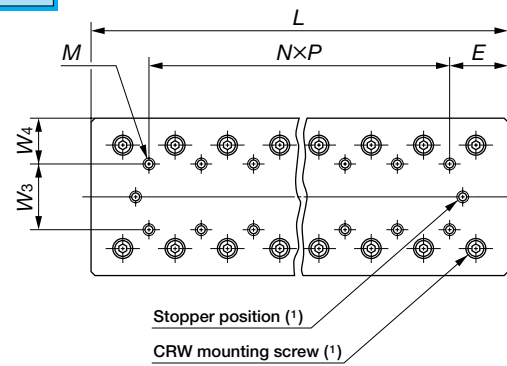

Model number	Mass (Ref.) kg	Boundary dimensions and tolerances mm								Table						
		W	Tolerance	H	Tolerance	L	t1	t2	t3	Maximum stroke length	W3	W4	N x P	E	M	W5
CRWU 80- 85	1.8	80	±0.1	35	±0.1	85	13	11	10.5	50	40	20	—	42.5	M5	60
CRWU 80-125	2.6					125				75			1 x 40			
CRWU 80-165	3.4					165				105			2 x 40			
CRWU 80-205	4.2					205				135			3 x 40			
CRWU 80-245	5.1					245				155			4 x 40			
CRWU 80-285	5.9					285				185			5 x 40			
CRWU 80-325	6.7					325				215			6 x 40			
CRWU 100-110	3.6					100				±0.15			45			
CRWU 100-160	5.2	160	95	1 x 50												
CRWU 100-210	6.9	210	130	2 x 50												
CRWU 100-260	8.5	260	165	3 x 50												
CRWU 100-310	10.2	310	200	4 x 50												
CRWU 100-360	11.8	360	235	5 x 50												
CRWU 100-410	13.5	410	265	6 x 50												
CRWU 145-210	13.2	145	±0.2	60	±0.1		210	21	22		16	130		85	30	—
CRWU 145-310	19.6					310	180			1 x 100						
CRWU 145-410	25.9					410	350			2 x 100						
CRWU 145-510	32.2					510	450			3 x 100						
CRWU 145-610	38.6					610	550			4 x 100						
CRWU 145-710	45.0					710	650			5 x 100						
CRWU 145-810	51.3					810	750			6 x 100						

Note(1) : This is the mounting position for the stopper or CRW mounting screw.  
For details, see page E-75.

Mounting dimensions mm														Basic dynamic load rating C N	Basic static load rating C0 N	Allowable load F N	Static moment rating T0 N·m		
W6	L1	E1	L2	E2	L3	E3	Bed L4	E4	L5	E5	d1	d2	h1					h2	
10	40	22.5	—	—	80	62.5	—	—	—	5.5	9.5	6	11	6 640	9 400	3 130	188		
	80													—	—	9 130	14 100	4 700	282
	120													10 300	16 500	5 480	329		
	160													12 500	21 200	7 050	423		
	200													14 700	25 900	8 620	517		
	240													16 700	30 600	10 200	611		
	280													18 700	35 300	11 800	705		
	102.5													11 800	16 500	5 480	329		
20	90	10	—	—	90	60	—	—	—	7	11	6.5	14	13 900	18 500	6 150	415		
	140													16 600	23 100	7 690	519		
	190													21 600	32 300	10 800	727		
	240													26 300	41 500	13 800	934		
	290													30 800	50 700	16 900	1 140		
	340													35 100	60 000	20 000	1 350		
	390													37 200	64 600	21 500	1 450		
	102.5													13 800	18 500	6 150	415		
27.5	100	55	—	—	100	155	—	—	—	9	14	8.5	17.5	39 400	52 800	17 600	1 900		
	200													61 200	92 300	30 800	3 320		
	300													67 900	106 000	35 200	3 800		
	400													74 400	119 000	39 600	4 270		
	500													87 100	145 000	48 400	5 220		
	600													99 200	172 000	57 200	6 170		
	700													111 000	198 000	66 000	7 120		
	355													11 800	16 500	5 480	329		

## Mounting dimensions of stopper and CRW CRWU

※ For mounting dimensions, refer to E78~81.

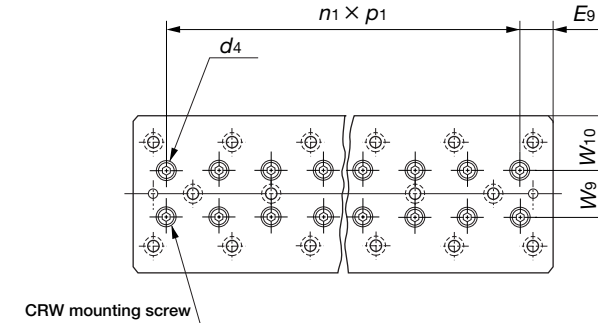
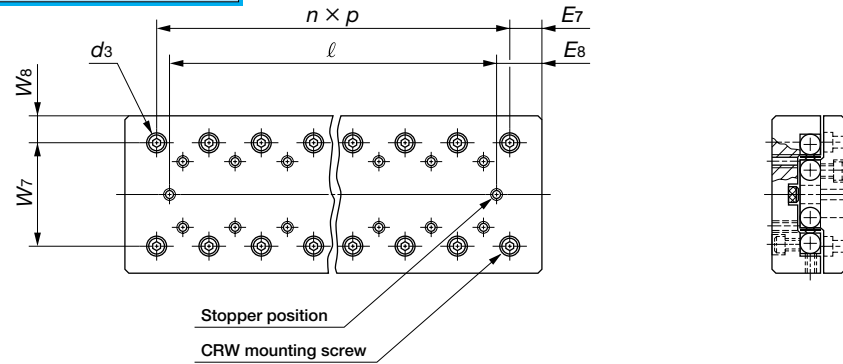

Model number	Dimensions of table mm							Dimensions of bed mm							
	W <sub>7</sub>	W <sub>8</sub>	n × p	E <sub>7</sub>	d <sub>3</sub>	ℓ	E <sub>8</sub>	W <sub>9</sub>	W <sub>10</sub>	n <sub>1</sub> × p <sub>1</sub>	E <sub>9</sub>	d <sub>4</sub>			
CRWU 30- 25	18.4	5.8	1 × 10	7.5	4.1	20	2.5	—	15	1 × 10	7.5	4.1			
CRWU 30- 35			2 × 10			26	4.5			2 × 10					
CRWU 30- 45			3 × 10			33	6			3 × 10					
CRWU 30- 55			4 × 10			40	7.5			4 × 10					
CRWU 30- 65			5 × 10			48	8.5			5 × 10					
CRWU 30- 75			6 × 10			53	11			6 × 10					
CRWU 30- 85			7 × 10			58	13.5			7 × 10					
CRWU 40- 35			25			7.5	1 × 15			10			6	29	3
CRWU 40- 50	25.5	7.25	1 × 25	12.5	6.5	41	4.5	2 × 15	10						
CRWU 40- 65			1 × 25	20		51	7	2 × 15	17.5						
CRWU 40- 80			2 × 25	15		61	9.5	4 × 15	10						
CRWU 40- 95			2 × 25	22.5		71	12	4 × 15	17.5						
CRWU 40-110			3 × 25	17.5		81	14.5	5 × 15	17.5						
CRWU 40-125			3 × 25	25		91	17	5 × 15	25						
CRWU 60- 55			39	10.5		1 × 25	15	7.5	44	5.5	17	21.5	1 × 25	15	7.5
CRWU 60- 80						2 × 25			59	10.5			2 × 25		
CRWU 60-105	3 × 25	74			15.5	3 × 25									
CRWU 60-130	4 × 25	89			20.5	4 × 25									
CRWU 60-155	5 × 25	104			25.5	5 × 25									
CRWU 60-180	6 × 25	119			30.5	6 × 25									
CRWU 60-205	7 × 25	144			30.5	7 × 25									

Model number	Dimensions of table mm							Dimensions of bed mm				
	W <sub>7</sub>	W <sub>8</sub>	n × p	E <sub>7</sub>	d <sub>3</sub>	ℓ	E <sub>8</sub>	W <sub>9</sub>	W <sub>10</sub>	n <sub>1</sub> × p <sub>1</sub>	E <sub>9</sub>	d <sub>4</sub>
CRWU 80- 85	53	13.5	1 × 40	22.5	9.5	64	10.5	27	26.5	1 × 40	22.5	9.5
CRWU 80-125			2 × 40			89	18			2 × 40		
CRWU 80-165			3 × 40			119	23			3 × 40		
CRWU 80- 205			4 × 40			149	28			4 × 40		
CRWU 80- 245			5 × 40			169	38			5 × 40		
CRWU 80-285			6 × 40			199	43			6 × 40		
CRWU 80-325			7 × 40			229	48			7 × 40		
CRWU 100-110			64			18	1 × 50			30		
CRWU 100-160	2 × 50	113		23.5	2 × 50							
CRWU 100-210	3 × 50	148		31	3 × 50							
CRWU 100-260	4 × 50	183		38.5	4 × 50							
CRWU 100-310	5 × 50	218		46	5 × 50							
CRWU 100-360	6 × 50	253		53.5	6 × 50							
CRWU 100-410	7 × 50	283		63.5	7 × 50							
CRWU 145-210	98	23.5		1 × 100	55		14	156	27		46	49.5
CRWU 145-310			2 × 100	206		52		2 × 100				
CRWU 145-410			3 × 100	376		17		3 × 100				
CRWU 145-510			4 × 100	476		17		4 × 100				
CRWU 145-610			5 × 100	576		17		5 × 100				
CRWU 145-710			6 × 100	676		17		6 × 100				
CRWU 145-810			7 × 100	776		17		7 × 100				

## CRWU...R

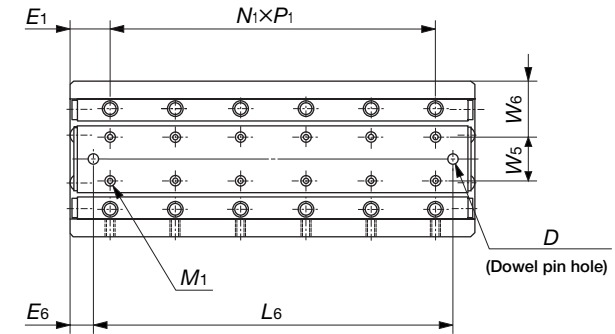
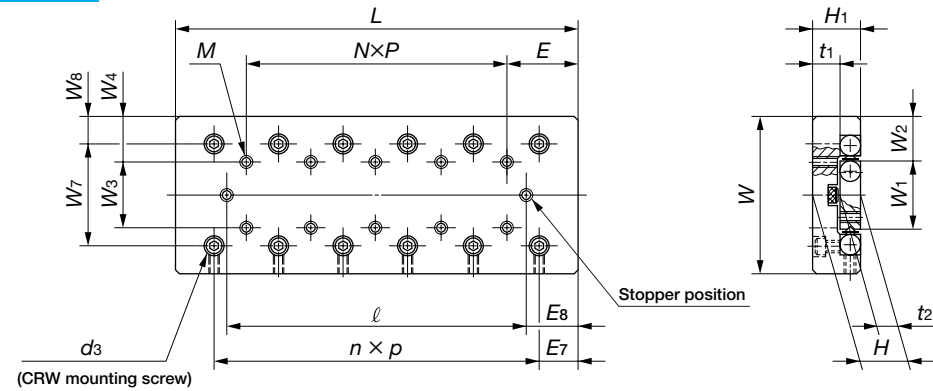

Model number	Mass (Ref.) kg	Boundary dimensions and tolerances mm					Dimensions of table mm										
		W	Tolerance	H	Tolerance	L	Maximum stroke length	Mounting dimensions									
							W <sub>3</sub>	W <sub>4</sub>	N × P	E	M	W <sub>7</sub>	W <sub>8</sub>	n × p	E <sub>7</sub>	d <sub>3</sub>	ℓ
CRWU 30- 25R	0.06					25			—					1 × 10			20
CRWU 30- 35R	0.08					35			1 × 10					2 × 10			26
CRWU 30- 45R	0.11					45			2 × 10					3 × 10			33
CRWU 30- 55R	0.13	30	±0.1	11	±0.1	55	10	10	3 × 10	12.5	M2	18.4	5.8	4 × 10	7.5	4.1	40
CRWU 30- 65R	0.16					65			4 × 10					5 × 10			48
CRWU 30- 75R	0.18					75			5 × 10					6 × 10			53
CRWU 30- 85R	0.21					85			6 × 10					7 × 10			58
CRWU 40- 35R	0.13			14		35			—			25	7.5	1 × 15	10	6	29
CRWU 40- 50R	0.21					50			1 × 15					1 × 25	12.5		41
CRWU 40- 65R	0.26					65			2 × 15					1 × 25	20		51
CRWU 40- 80R	0.34	40	±0.1	15	±0.1	80	15	12.5	3 × 15	17.5	M3	25.5	7.25	2 × 25	15	6.5	61
CRWU 40- 95R	0.38					95			4 × 15					2 × 25	22.5		71
CRWU 40-110R	0.46					110			5 × 15					3 × 25	17.5		81
CRWU 40-125R	0.50					125			6 × 15					3 × 25	25		91
CRWU 60- 55R	0.44					55			—					1 × 25			44
CRWU 60- 80R	0.66					80			1 × 25					2 × 25			59
CRWU 60-105R	0.85					105			2 × 25					3 × 25			74
CRWU 60-130R	1.1	60	±0.1	18.5	±0.1	130	25	17.5	3 × 25	27.5	M4	39	10.5	4 × 25	15	7.5	89
CRWU 60-155R	1.3					155			4 × 25					5 × 25			104
CRWU 60-180R	1.5					180			5 × 25					6 × 25			119
CRWU 60-205R	1.7					205			6 × 25					7 × 25			144

Model number		Dimensions and tolerance of center way mm													Basic dynamic load rating C N	Basic static load rating C <sub>0</sub> N	Allowable load F N	Static moment rating T <sub>0</sub> N·m
		Mounting dimensions																
E <sub>8</sub>	H <sub>1</sub>	t <sub>1</sub>	W <sub>5</sub>	W <sub>6</sub>	N <sub>1</sub> × P <sub>1</sub>	E <sub>1</sub>	M <sub>1</sub>	D	Tolerance	L <sub>6</sub>	E <sub>6</sub>	W <sub>1</sub>	W <sub>2</sub>	t <sub>2</sub>				
2.5					1 × 10			—	—	—	—				380	478	159	3.2
4.5					2 × 10			—	—	—	—				525	717	239	4.8
6					3 × 10			—	—	—	—				659	956	319	6.5
7.5	11	7	—	15	4 × 10	7.5	M2	2		30	12.5	12.8	8.6	4	786	1 200	398	8.1
8.5					5 × 10			2	+0.020 0	40	12.5				906	1 430	478	9.7
11					6 × 10			2		50	12.5				1 020	1 670	558	11.3
13.5					7 × 10			2		60	12.5				1 140	1 910	638	12.9
3	14	8			1 × 15	10		—	—	—	—	17	11.5	6	896	1 180	392	10.6
4.5					2 × 15	10		—	—	—	—				2 710	3 660	1 220	26.5
7					2 × 15	17.5		—	—	—	—				2 710	3 660	1 220	26.5
9.5	15	7	—	20	4 × 15	10	M3	3		45	17.5	13.1	13.45	8	4 050	6 090	2 030	44.2
12					4 × 15	17.5		3	+0.020 0	45	25				3 400	4 880	1 630	35.3
14.5					5 × 15	17.5		3		60	25				4 680	7 310	2 440	53.0
17					5 × 15	25		3		60	32.5				4 680	7 310	2 440	53.0
5.5					1 × 25					35					2 710	3 660	1 220	51.2
10.5					2 × 25					60					4 050	6 090	2 030	85.3
15.5					3 × 25					85					5 270	8 530	2 840	119
20.5	18.5	10.5	17	21.5	4 × 25	15	M4	4	+0.020 0	110	10	26.6	16.7	8	5 860	9 750	3 250	137
25.5					5 × 25					135					6 970	12 200	4 060	171
30.5					6 × 25					160					8 040	14 600	4 880	205
30.5					7 × 25					185					8 550	15 800	5 280	222



## CRWU...R

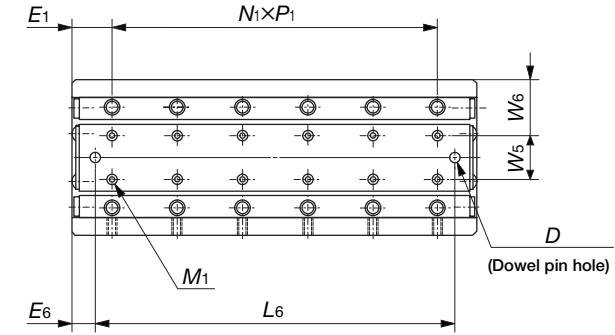
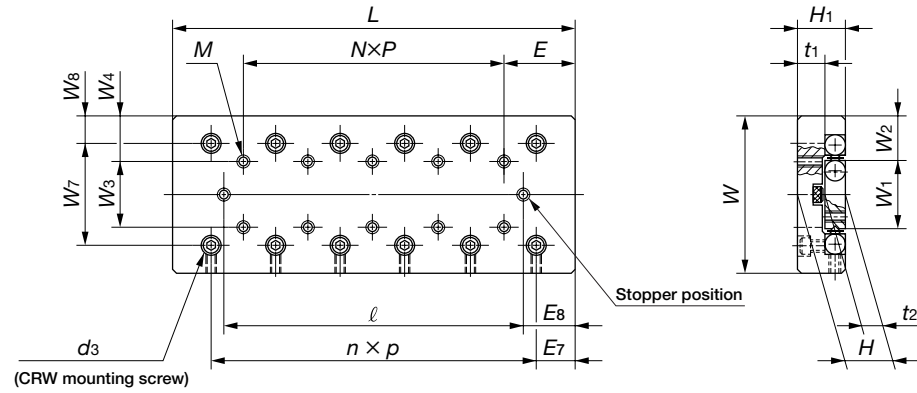

Model number	Mass (Ref.) kg	Boundary dimensions and tolerances mm					Dimensions of table mm										
		W		H		L	Mounting dimensions					Dimensions of table mm					
		W	Tolerance	H	Tolerance	L	W <sub>3</sub>	W <sub>4</sub>	N × P	E	M	W <sub>7</sub>	W <sub>8</sub>	n × p	E <sub>7</sub>	d <sub>3</sub>	ℓ
CRWU 80- 85R	1.2					85	50	-						1 × 40			64
CRWU 80-125R	1.8					125	75	1 × 40					2 × 40			89	
CRWU 80-165R	2.3					165	105	2 × 40					3 × 40			119	
CRWU 80-205R	2.9	80	±0.1	24	±0.1	205	135	3 × 40	42.5	M5	53	13.5	4 × 40	22.5	9.5	149	
CRWU 80-245R	3.5					245	155	4 × 40					5 × 40			169	
CRWU 80-285R	4.0					285	185	5 × 40					6 × 40			199	
CRWU 80-325R	4.6					325	215	6 × 40					7 × 40			229	
CRWU 100-110R	2.4					110	60	-					1 × 50			77	
CRWU 100-160R	3.6					160	95	1 × 50					2 × 50			113	
CRWU 100-210R	4.7					210	130	2 × 50					3 × 50			148	
CRWU 100-260R	5.9	100	±0.15	31	±0.1	260	165	3 × 50	55	M6	64	18	4 × 50	30	11	183	
CRWU 100-310R	7.0					310	200	4 × 50					5 × 50			218	
CRWU 100-360R	8.1					360	235	5 × 50					6 × 50			253	
CRWU 100-410R	9.3					410	265	6 × 50					7 × 50			283	
CRWU 145-210R	9.4					210	130	-					1 × 100			156	
CRWU 145-310R	13.9					310	180	1 × 100					2 × 100			206	
CRWU 145-410R	18.4					410	350	2 × 100					3 × 100			376	
CRWU 145-510R	23.0	145	±0.2	42.5	±0.1	510	450	3 × 100	105	M8	98	23.5	4 × 100	55	14	476	
CRWU 145-610R	27.5					610	550	4 × 100					5 × 100			576	
CRWU 145-710R	32.0					710	650	5 × 100					6 × 100			676	
CRWU 145-810R	36.6					810	750	6 × 100					7 × 100			776	

		Dimensions and tolerance of center way mm														Basic dynamic load rating	Basic static load rating	Allowable load	Static moment rating
		Mounting dimensions											C N	C <sub>0</sub> N	F N	T <sub>0</sub> N·m			
E <sub>8</sub>	H <sub>1</sub>	t <sub>1</sub>	W <sub>5</sub>	W <sub>6</sub>	N <sub>1</sub> × P <sub>1</sub>	E <sub>1</sub>	M <sub>1</sub>	D	Tolerance	L <sub>6</sub>	E <sub>6</sub>	W <sub>1</sub>					W <sub>2</sub>	t <sub>2</sub>	
10.5					1 × 40					55					6 640	9 400	3 130	188	
18					2 × 40					95					9 130	14 100	4 700	282	
23					3 × 40					135					10 300	16 500	5 480	329	
28	24	13	27	26.5	4 × 40	22.5	M5	5	+0.020 0	175	15	38	21	11	12 500	21 200	7 050	423	
38					5 × 40					215					14 700	25 900	8 620	517	
43					6 × 40					255					16 700	30 600	10 200	611	
48					7 × 40					295					18 700	35 300	11 800	705	
16.5					1 × 50					70					13 900	18 500	6 150	415	
23.5					2 × 50					120					16 600	23 100	7 690	519	
31					3 × 50					170					21 600	32 300	10 800	727	
38.5	31	16	26	37	4 × 50	30	M6	5	+0.020 0	220	20	42	29	15	26 300	41 500	13 800	934	
46					5 × 50					270					30 800	50 700	16 900	1 140	
53.5					6 × 50					320					35 100	60 000	20 000	1 350	
63.5					7 × 50					370					37 200	64 600	21 500	1 450	
27					1 × 100					150					39 400	52 800	17 600	1 900	
52					2 × 100					250					61 200	92 300	30 800	3 320	
17					3 × 100					350					67 900	106 000	35 200	3 800	
17	43	21	46	49.5	4 × 100	55	M8	5	+0.020 0	450	30	68.4	38.3	21	74 400	119 000	39 600	4 270	
17					5 × 100					550					87 100	145 000	48 400	5 220	
17					6 × 100					650					99 200	172 000	57 200	6 170	
17					7 × 100					750					111 000	198 000	66 000	7 120	

## CRWU...RS

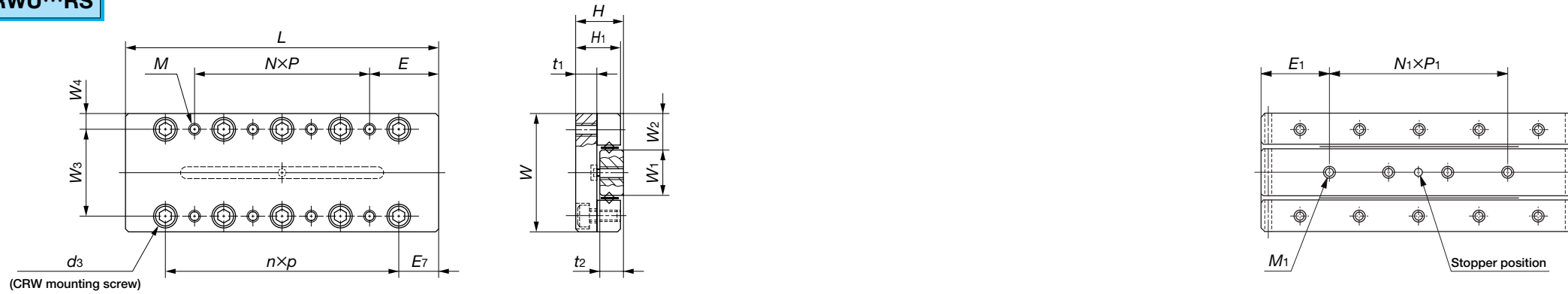

Model number	Mass (Ref.) kg	Boundary dimensions and tolerances mm						Dimensions of table mm					
		W	Tolerance	H	Tolerance	L	Maximum stroke length	Mounting dimensions					
								W <sub>3</sub>	W <sub>4</sub>	N x P	E	M	n x p
CRWU 20- 25RS	0.03	20	±0.1	8	±0.1	25	12	14	3	1 x 18	3.5	M2.5	1 x 10
CRWU 20- 35RS	0.05					35	18			1 x 28	3.5		2 x 10
CRWU 20- 45RS	0.06					45	25			1 x 20	12.5		3 x 10
CRWU 20- 55RS	0.07					55	32			1 x 30	12.5		4 x 10
CRWU 30- 65RS	0.20	30	±0.1	12	±0.1	65	40	22	4	1 x 30	17.5	M3	3 x 15
CRWU 30- 80RS	0.24					80	50			1 x 45			5 x 15
CRWU 30- 95RS	0.29					95	60			2 x 30			
CRWU 40-105RS	0.58	40	±0.1	16	±0.1	105	60	30	5	1 x 50	27.5	M4	3 x 25
CRWU 40-130RS	0.72					130	75			1 x 75			4 x 25
CRWU 40-155RS	0.85					155	90			2 x 50			5 x 25

E <sub>7</sub>	d <sub>3</sub>	H <sub>1</sub>	t <sub>1</sub>	Dimensions of center way mm						Basic dynamic load rating C N	Basic static load rating C <sub>0</sub> N	Allowable load F N	Static moment rating T <sub>0</sub> N·m
				Mounting dimensions									
				W <sub>1</sub>	W <sub>2</sub>	N <sub>1</sub> x P <sub>1</sub>	E <sub>1</sub>	M <sub>1</sub>	t <sub>2</sub>				
7.5	4.1	7.5	3.5	7	6.5	2 x 7.5	5	M2.5	4	380	478	159	1.8
						2 x 10	7.5			525	717	239	2.8
						3 x 10				659	956	319	3.7
						4 x 10				786	1 200	398	4.6
10	6	11.5	5.5	12	9	3 x 15	10	M3	6	1 850	2 940	979	19.1
						4 x 15				2 130	3 530	1 180	22.9
						5 x 15				2 410	4 110	1 370	26.7
15	7.5	15.5	7.5	16	12	3 x 25	15	M4	8	4 680	7 310	2 440	63.6
						4 x 25				5 860	9 750	3 250	84.8
						5 x 25				6 970	12 200	4 060	106

# Precision Linear Slides

Description of each series and Table of dimensions

## High Rigidity Precision Linear Slide Unit

Page E-92 to E-103



## Precision Linear Slide

Page E-104 to E-118

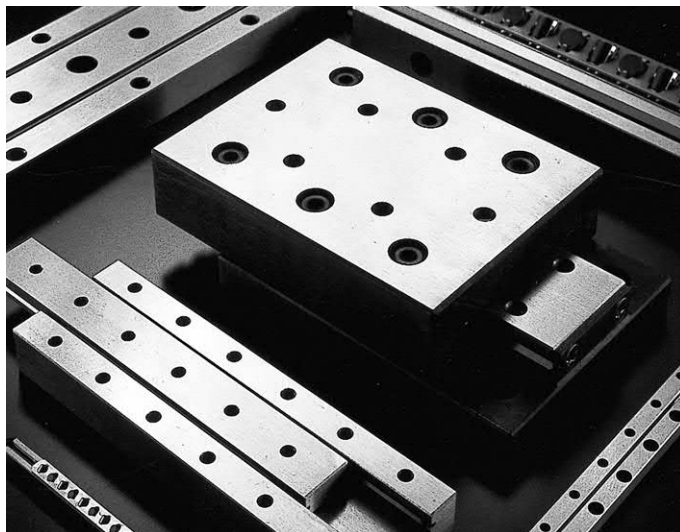

In the table of dimensions, standard products are referred to using identification numbers marked with  . The identification numbers marked with   refer to our semi-standard products.

U.S. PATENTED

# High Rigidity Precision Linear Slide Unit

**BWU**

**I**KO High Rigidity Precision Linear Slide Unit BWU is a compact linear motion rolling guide for limited stroke length. The unit incorporates two rows of steel balls in four point contact with the raceways so that stable accuracy and high rigidity are obtained even under fluctuating and complex loads. Wide variations in size are available for selections suitable for each application.

## High accuracy and smooth movement

Two raceways on the solid table and on the solid bed respectively are ground at one time to minimize processing errors and improve accuracy between the two raceways. High accuracy and smooth movement are assured.

## Stainless steel type

All components are made of stainless steel to give superior corrosion and heat resistance. So this series is most suitable for use in clean rooms.

U.S. PATENT No. 5,213,420  
No. 5,213,419

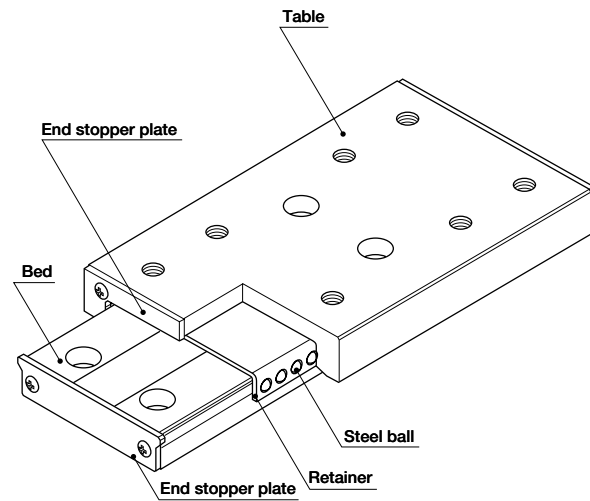

Structure of High Rigidity Precision Linear Slide Unit BWU

## Identification number and specification

The specification of High Rigidity Precision Linear Slide Unit BWU is indicated by the identification number, consisting of a model code and a size. An example of identification number is shown below.

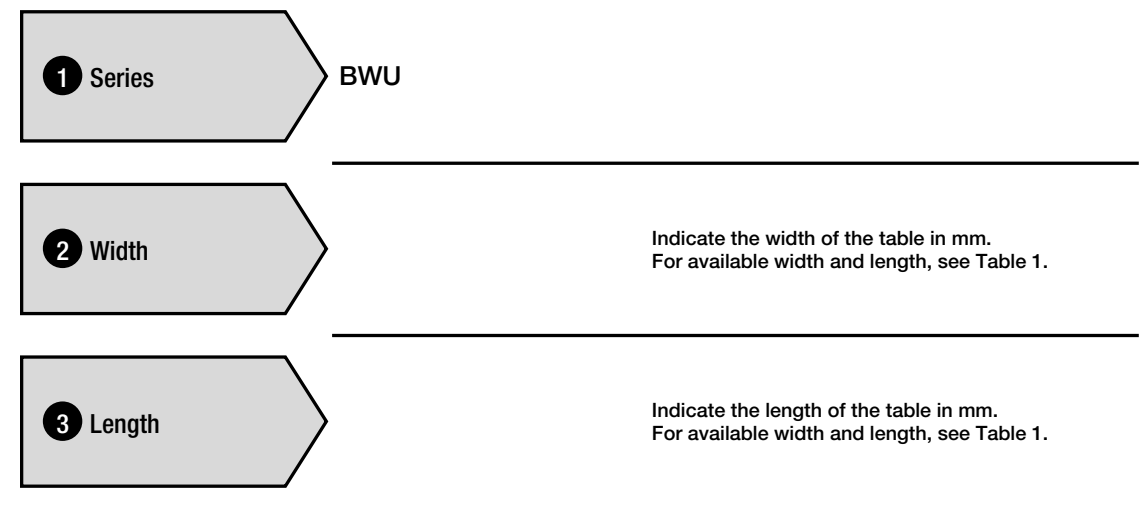
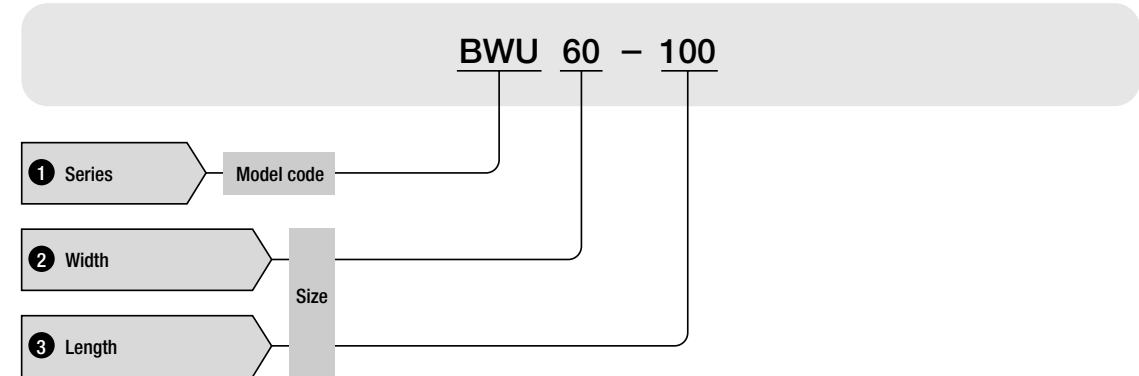
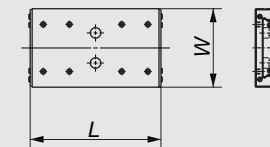

Table 1 Width and length



Model number		BWU 6	BWU 8	BWU 12	BWU 17	BWU 25	BWU 30	BWU 40	BWU 60
Item	Width W	6	8	12	17	25	30	40	60
	Length L	10	10	20	20	30	30	40	60
20		20	30	30	45	45	60	80	
30		30	45	45	60	60	80	100	
						75	75	100	120
							90		

unit : mm

# Load Rating

The load ratings of High Rigidity Precision Linear Slide Unit BWU are defined for downward load. Summarized descriptions of load ratings are given below. For details of load rating definitions and load calculations, see "General description".

## Basic dynamic load rating $C$

The basic dynamic load rating is defined as the constant load both in direction and magnitude under which a group of identical High Rigidity Precision Linear Slide Units BWU are individually operated and 90% of the units in the group can travel  $50 \times 10^3$  meters free from material damage due to rolling contact fatigue.

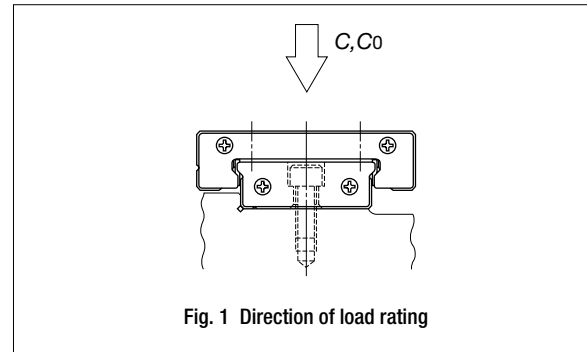

## Basic static load rating $C_0$

The basic static load rating is defined as the static load that gives a prescribed constant contact stress at the center of the contact area between the rolling element and raceway receiving the maximum load.

## Allowable load $F$

Allowable load is the load under which the sum of elastic deformations of the rolling element and the raceway in the contact area subjected to the maximum contact stress is small enough to guarantee accuracy and smooth rolling movement.

Therefore, when very smooth and highly accurate linear motion is required, make sure that the applied load is well within the allowable load value.

## Static moment rating $T_0$

The static moment rating is defined as the static moment load that gives a prescribed constant contact stress at the center of the contact area between the rolling element and raceway receiving the maximum load when a moment is loaded.

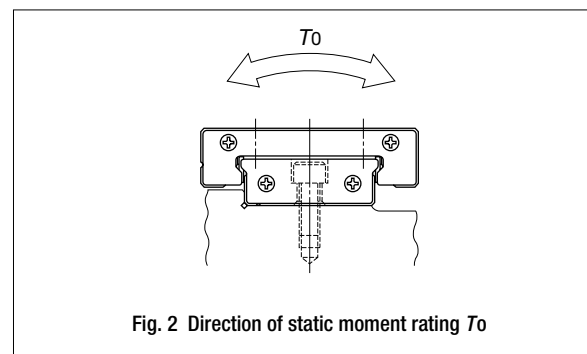

## Load direction and load rating

Since the load ratings of High Rigidity Precision Linear Slide Unit BWU given in the table of dimensions are for downward load, they must be corrected for the load direction for upward or lateral load. The corrected basic dynamic load ratings and basic static load ratings are shown in Table 2.

Table 2 Load ratings corrected for the load direction

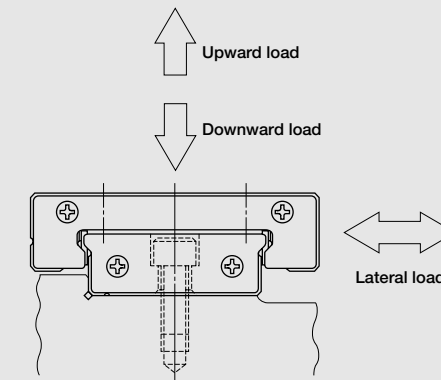

Load rating	Basic dynamic load rating	Basic static load rating
Downward	$C$	$C_0$
Upward	$C$	$C_0$
Lateral	$1.19C$	$1.19C_0$

## Accuracy

The accuracy of High Rigidity Precision Linear Slide Unit BWU is shown in Tables 3 and 4.

Table 3 Accuracy

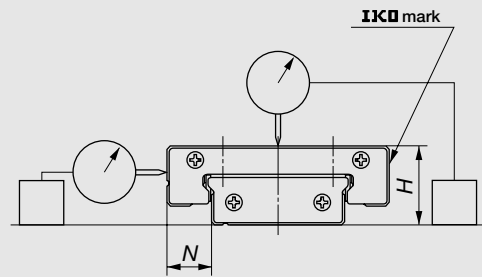

unit : mm

Item	Deviation and variation
Dim. H tolerance	±0.040
Dim. N tolerance	±0.050
Parallelism at table center	See Table 4.
Parallelism at table side	See Table 4.

Table 4 Running accuracy

unit : μm

Nominal length L mm		Parallelism at table center <sup>(1)</sup>	Parallelism at table side <sup>(2)</sup>
over	incl.		
—	50	4	6
50	80	5	8
80	120	6	9

Note<sup>(1)</sup> : The value of parallelism at table center shows the difference between the maximum and the minimum of unit height measured at the table center when the table is stroked.

(2) : The value of parallelism at table side shows the difference between the maximum and the minimum values measured at the table side (Opposite side of **IKO** mark) when the table is stroked.

## Preload

Preload of High Rigidity Precision Linear Slide Unit BWU is adjusted to a proper amount at **IKO** factory.

## Precautions for Use

- High Rigidity Precision Linear Slide Unit BWU is coated with rust preventive oil. Wash it with clean liquid before assembling and lubricate it by coating with good quality oil or grease.
- High Rigidity Precision Linear Slide Unit BWU does not incorporate a mechanical stopper. When over stroke is expected during the operation, prepare a stopper system on the adjoining equipment.
- When high running accuracy is needed, the load should be applied at around the center of the table (or bed) and avoid stroking the table in full length.
- Sometimes, retainers may shift from the normal position due to unbalanced loading and/or irregular and high speed operation. To remedy for such phenomena, move High Rigidity Precision Linear Slide Unit BWU in full stroke at some intervals during operation prescribed either in time or number of strokes.
- High Rigidity Precision Linear Slide Unit BWU can be used at high temperatures, because it does not have resin parts. However, if the operating temperature is over 100°C, consult **IKO**.
- Use High Rigidity Precision Linear Slide Unit BWU at speeds lower than 30 m/min.
- The tightening depth of screws on the table should be less than the values shown in the dimension table. If the tightening depth is larger than these values, the screw will push the bed as the screw hole in the table is a through hole and the running accuracy and life will deteriorate.

# Precautions for Mounting

## 1 Reference mounting surface

The reference mounting surface of High Rigidity Precision Linear Slide Unit BWU is the side surface opposite to the **IJKO** mark. (See Fig. 3.)

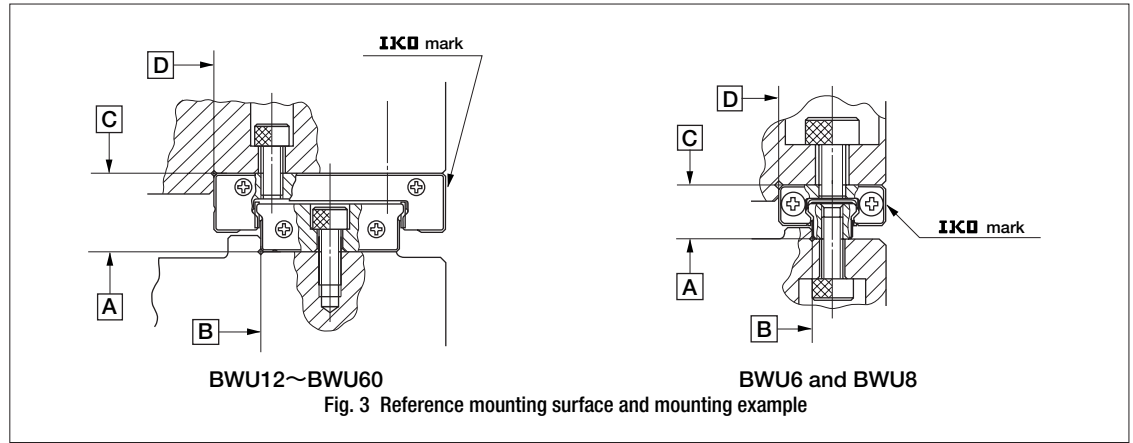

## 2 General mounting example

As shown in Fig. 3, the reference mounting surfaces **B** and **D** and the mounting surfaces **A** and **C** are precisely finished by grinding. Stable linear motion with high accuracy will be obtained by correctly mounting the unit on the reference mounting surfaces and the mounting surfaces of the machine which will be precisely finished.

It is recommended to make a relieved fillet at the corners of the mating reference mounting surfaces as shown in the figure in Table 5. Recommended shoulder heights of the mating reference mounting surfaces are given in Table 5.

Table 5 Shoulder heights of the mating reference mounting surfaces unit : mm

Model number	Table Shoulder height $h_1$	Bed Shoulder height $h_2$
BWU 6- ...	1	0.5
BWU 8- ...	1.2	0.8
BWU 12- ...	1.5	0.8
BWU 17- ...	2.5	1.2
BWU 25- ...	2.5	1.5
BWU 30- ...	3	2
BWU 40- ...	3	2.5
BWU 60- ...	4	2.5

## 3 When lateral load is predominant

As shown in Fig. 4, fix the side surface of the table and the side surface of the bed securely onto the machine with a pressure plate, etc.

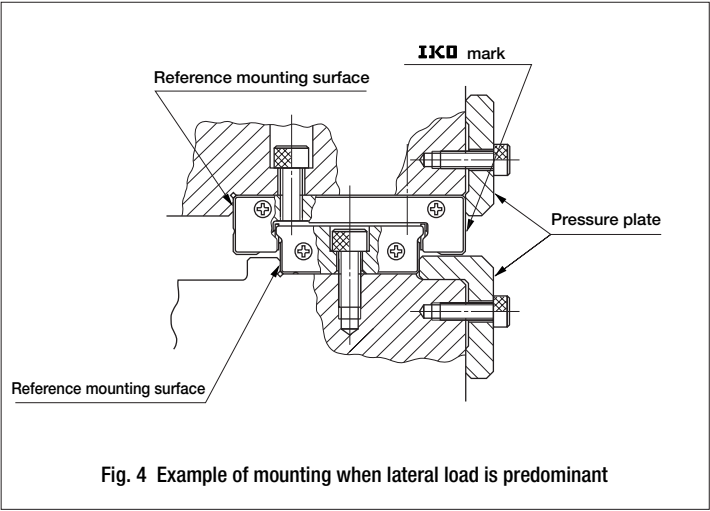

## 4 Mounting bolt tightening torque

Table 6 shows the mounting bolt tightening torque in general application when the mating parts are made of steel and hexagon socket head stainless steel bolts (equivalent to JIS property division A2-70) are used. According to the material of mating parts and the operating conditions, increase or decrease the amount of tightening torque.

Table 6 Mounting bolt tightening torque

Bolt size	Tightening torque N·m
M1 × 0.25	0.04
M1.4 × 0.3	0.10
M1.6 × 0.35	0.15
M2 × 0.4	0.31
M3 × 0.5	1.1
M4 × 0.7	2.5

## BWU

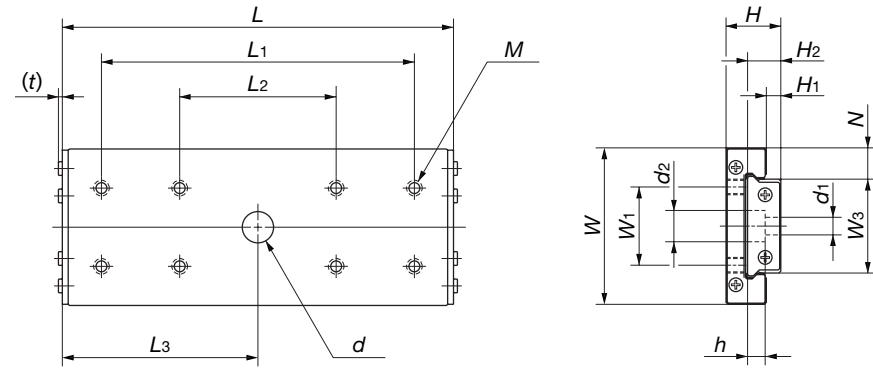

Model number	Mass (Ref.) g		Nominal dimensions mm					Dimensions of table mm						
	Table	Bed	W	H	H <sub>1</sub>	N	L	Maximum stroke length	W <sub>1</sub>	L <sub>1</sub>	L <sub>2</sub>	M	Maximum tightening depth	
<b>BWU 6- 10</b>	0.72	0.23	6	3.2	0.7	2	10	3	—	4	—	M1.4	0.8	
<b>BWU 6- 20</b>	1.6	0.50					20	11	—	10	—			
<b>BWU 6- 30</b>	2.4	0.78					30	16	—	18	10			
<b>BWU 8- 10</b>	0.96	0.42	8	4	1	2.5	10	4	—	5.5	—	M2	0.8	
<b>BWU 8- 20</b>	2.2	0.97					20	16	—	10	—			
<b>BWU 8- 30</b>	3.3	1.5					30	20	—	21	10			
<b>BWU 12- 20<sup>(1)</sup></b>	3.6	1.9	12	4.5	1	3	20	16	—	8	—	M2	1.1	
<b>BWU 12- 30<sup>(1)</sup></b>	5.7	3.2					30	20	—	15	—			
<b>BWU 12- 45<sup>(1)</sup></b>	8.5	4.9					45	30	—	31	15			
<b>BWU 17- 20</b>	9.2	3.9	17	8	1.5	5	20	14	12	10	—	M2	3	
<b>BWU 17- 30</b>	17.8	7.8					30	19		—	20			—
<b>BWU 17- 45</b>	26.5	11.7					45	29		—	30			—
<b>BWU 25- 30</b>	22.5	13.3	25	9	1.8	5.5	30	23	10	15	—	M3	2.5	
<b>BWU 25- 45</b>	41.6	24.3					45	28		—	25			—
<b>BWU 25- 60</b>	55.7	33.0					60	38		—	25			—
<b>BWU 25- 75</b>	68.4	40.8					75	48		—	55			25
<b>BWU 30- 30</b>	31.9	25.0	30	12	3.4	6	30	23	14	15	—	M3	3	
<b>BWU 30- 45</b>	56.9	45.4					45	29		—	25			—
<b>BWU 30- 60</b>	76.1	61.5					60	35		—	25			—
<b>BWU 30- 75</b>	93.8	76.1					75	47		—	55			25
<b>BWU 30- 90</b>	101	84.8					90	59		—	55			25

Note<sup>(1)</sup> : Special mounting bolts for mounting the bed (cross recessed head cap screws for precision equipment M2 x 4) are appended to BWU12.

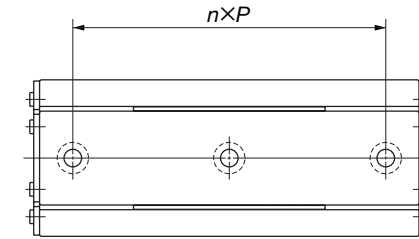

L <sub>3</sub>	d	t	Dimensions of bed mm						Basic dynamic load rating C N	Basic static load rating C <sub>0</sub> N	Allowable load F N	Static moment rating T <sub>0</sub> N·m	
			W <sub>3</sub>	H <sub>2</sub>	n	P	d <sub>1</sub>	d <sub>2</sub>					h
—	—	0.46	2	1.9	1	4	M1.0 Thru hole	—	—	154	181	60.2	0.21
—	—				1	8		—	—	252	361	120	0.42
—	—				2	8		—	—	355	587	196	0.68
—	—	0.45	3	2.6	1	5	M1.6 Thru hole	—	—	203	212	70.6	0.36
—	—				1	10		—	—	292	353	118	0.60
—	—				2	10		—	—	442	635	212	1.1
—	—	0.45	6	2.8	1	7.5	2.4	4	1.5	292	353	118	1.1
—	—				1	15				442	635	212	2.0
22.5	4.5				2	15				603	988	329	3.2
10	4.5	0.8	7	5	1	7.5	2.4	4.2	2.3	588	635	212	2.5
—	—				1	15				874	1 110	370	4.4
22.5	4.5				2	15				1 200	1 750	582	6.9
—	—	0.9	14	5.2	1	15	3.5	6	3.2	783	953	318	7.1
—	—				1	30				1 200	1 750	582	13.0
—	—				1	30				1 490	2 380	794	17.7
37.5	6.5				2	30				1 760	3 020	1 010	22.5
—	—	1.0	18	7.5	1	15	3.5	6.5	4.5	1 270	1 410	470	13.4
—	—				1	30				1 920	2 540	847	24.1
—	—				1	30				2 490	3 670	1 220	34.9
37.5	6.5				2	30				2 880	4 520	1 510	42.9
45	6.5	—	—	—	2	30	—	—	—	3 250	5 360	1 790	50.9



## BWU

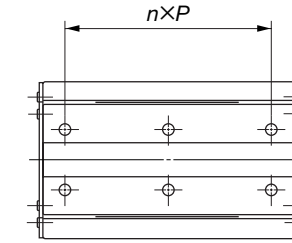
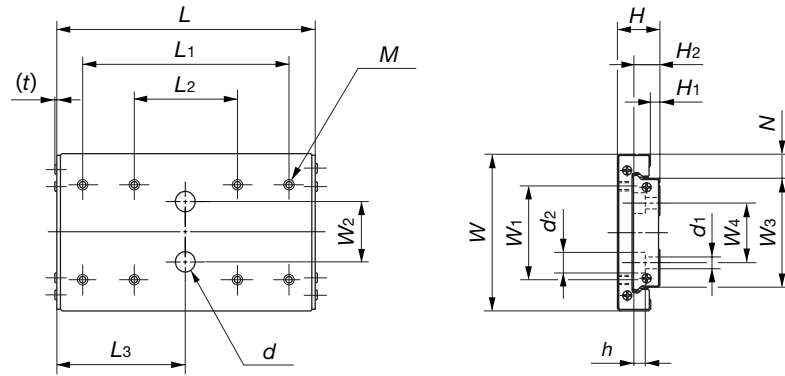

Model number	Mass (Ref.) g		Nominal dimensions mm					Dimensions of table mm					
	Table	Bed	W	H	H <sub>1</sub>	N	L	Maximum stroke length	W <sub>1</sub>	L <sub>1</sub>	L <sub>2</sub>	M	Maximum tightening depth
<b>BWU 40- 40</b>	68.9	52.0	40	14	3.5	8	40	31	20	20	—	M4	4
<b>BWU 40- 60</b>	125	93.0					60	39		40	—		
<b>BWU 40- 80</b>	167	125					80	47		40	—		
<b>BWU 40-100</b>	207	155					100	63		80	40		
<b>BWU 60- 60</b>	195	194	60	16	3.6	9	60	34	36	40	—	M4	4
<b>BWU 60- 80</b>	261	261					80	45		40	—		
<b>BWU 60-100</b>	321	325					100	56		80	40		
<b>BWU 60-120</b>	386	391					120	68		100	40		

				Dimensions of bed mm							Basic dynamic load rating	Basic static load rating	Allowable load	Static moment rating					
W <sub>2</sub>	L <sub>3</sub>	d	t	W <sub>3</sub>	H <sub>2</sub>	W <sub>4</sub>	n	P	d <sub>1</sub>	d <sub>2</sub>	h	C N	C <sub>0</sub> N	F N	T <sub>0</sub> N·m				
—	—	—	1.0	24	8.5	—	1	20	4.5	8	4.5	2 040	2 210	735	27.8				
—	—	—					1	40				3 100	3 970	1 320	50.0				
—	—	—					1	40				4 010	5 730	1 910	72.2				
—	50	8					2	40				4 640	7 060	2 350	88.9				
—	—	—	1.1	42	10	23	1	40	4.5	8	4.5	4 740	5 690	1 900	124				
—	—	—					1					40	4.5	8	4.5	5 930	7 820	2 610	171
23	50	8					2									7 020	9 960	3 320	217
23	60	8					2					8 050	12 100	4 030	264				

# Precision Linear Slide

BSP/BSPG/BSR

**IKO Precision Linear Slide** is a light weight and compact linear motion rolling guide, comprising a U-shaped table (or slide unit race) and bed (or track rail) made from stainless steel sheet by precision forming. The raceway grooves are accurately ground on the table (or slide unit race) and bed (or track rail). Precision Linear Slide features high performance and durability, making this series suitable for measuring equipment, disk drives, IC manufacturing and inspection devices, etc. Wide variations in performance and size are available for selections suitable for each application.

## Superior corrosion resistance

The balls, table, bed and other steel components are made of stainless steel. So this series is superior in corrosion resistance and most suitable for use in clean rooms.

## Quiet and smooth motion

The advanced design of ball retainers and circulators combined with precise grinding of raceways minimizes noise and gives smooth motion with low frictional resistance. So superior positioning accuracy and response can be obtained during operation even for a very small feed motion.

## High safety

All organic components are made of nonflammable or self-extinguishing materials. So this series may be used in home appliances and office equipment.

## Light weight and compact

A simple structural design minimizes the number of components, offering reduced size and weight of sliding members in machines and equipment.

## Stable performance

The steel balls are arranged in two rows with each ball contacting the raceways at four points. So stable load capacity is assured for loads in all directions. In addition, the simple design minimizes errors in manufacturing and assembly, ensuring high operating accuracy.

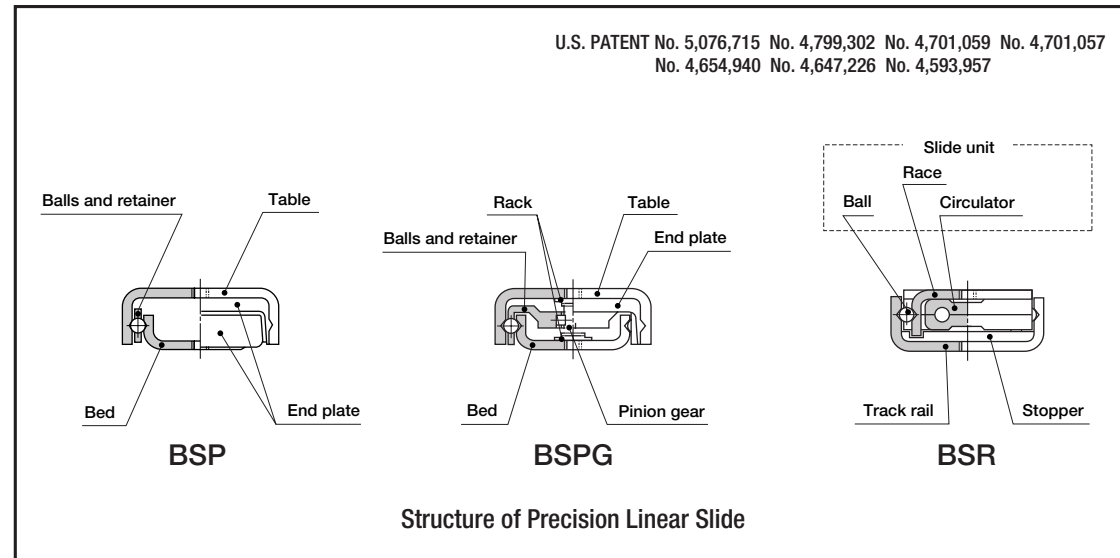

## Precision Linear Slide series

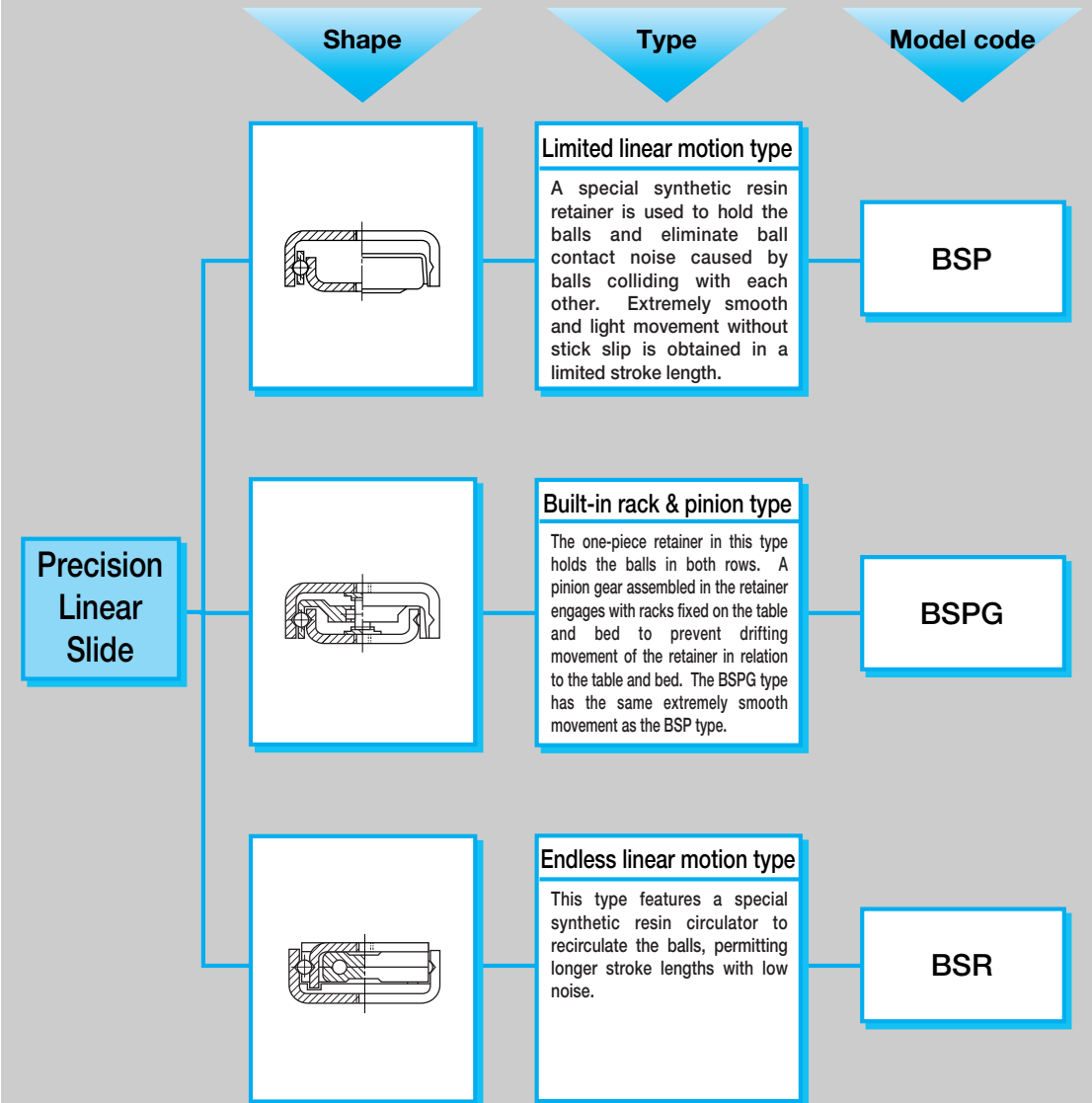

## Identification number and specification

The specification of Precision Linear Slide is indicated by the identification number, consisting of a model code, a size, a material symbol and a clearance symbol.

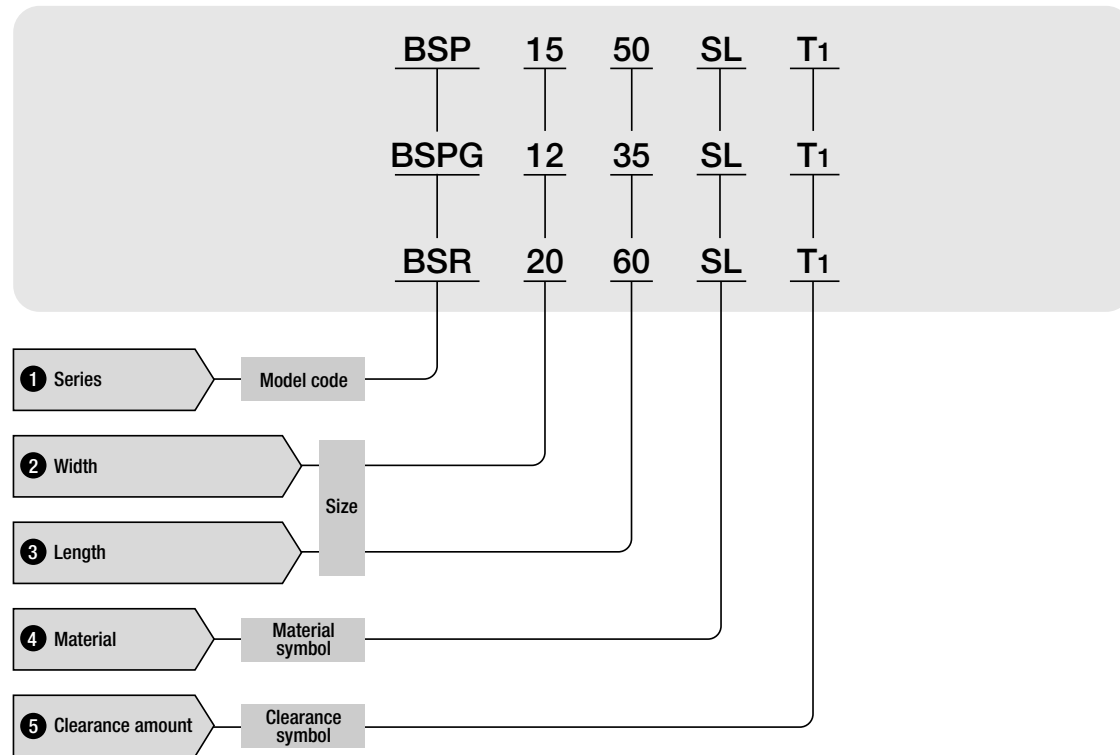

**1 Series**

Limited linear motion type : **BSP**  
 Built-in rack & pinion type : **BSPG** For available types and widths, see Table 1.  
 Endless linear motion type : **BSR**

**2 Width**

Indicate the width in mm.

Table 1 Types and widths

Type \ Width	BSP	BSPG	BSR
7	○	—	—
10	○	—	—
12	—	○	○
15	○	○	○
20	○	○	○
25	○	○	○

**3 Length**

Indicate the length in mm.

**4 Material**

Stainless steel made : **SL** Only stainless steel type "SL" is indicated.

**5 Clearance amount**

Standard : No symbol  
 T1 clearance : **T1** For details of clearance amount, see Table 2.

**Clearance**

Internal clearances of Precision Linear Slide are shown in Table 2. Generally, standard clearance is recommended for applications requiring low friction. T1 clearance is generally suitable for applications requiring more accurate linear movement.

Clearance type and symbol	Clearance between raceways and balls
Standard (No symbol)	0 ~ +4
<b>T1</b>	-4 ~ 0

unit : μm

## Load Rating

Summarized descriptions of load ratings of Precision Linear Slide are given below. For details of load rating definitions and load calculations, see "General description".

### Basic dynamic load rating $C$

The basic dynamic load rating is defined as the constant load both in direction and magnitude under which a group of identical Precision Linear Slides are individually operated and 90% of the units in the group can travel  $50 \times 10^3$  meters free from material damage due to rolling contact fatigue.

### Basic static load rating $C_0$

The basic static load rating is defined as the static load that gives a prescribed constant contact stress at the center of the contact area between the rolling element and raceway receiving the maximum load.

## Accuracy

The accuracy of Precision Linear Slide in operation is shown in Tables 3 and 4.

Table 3 Accuracy of BSP type and BSPG type

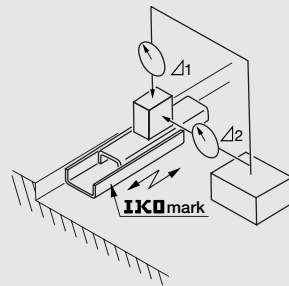

Stroke length mm		Parallelism in operation between bed center and mounting surface of table $\Delta 1$	Parallelism in operation between bed center and reference mounting surface of table $\Delta 2$
over	incl.		
—	18	3	6
18	30	4	8
30	50	5	10
50	80	6	12

unit :  $\mu\text{m}$

Table 4 Accuracy of BSR type

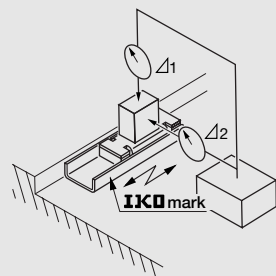

Stroke length mm		Parallelism in operation between slide unit center and mounting surface of track rail $\Delta 1$	Parallelism in operation between slide unit center and reference mounting surface of track rail $\Delta 2$
over	incl.		
—	18	3	6
18	30	4	8
30	50	5	10
50	80	6	12

unit :  $\mu\text{m}$

## Precautions for Use

- ① To obtain consistently high accuracy in operation, the applied load should not exceed 20% of the basic static load rating.
- ② To maximize the accuracy of BSP or BSPG type, center the applied load over the table or bed. Allow enough additional stroke length to avoid reaching the maximum stroke length.
- ③ Unevenly applied loads and high fluctuating velocities may dislocate the position of the ball retainer in the BSP type. Therefore, it is recommended that the retainer is periodically repositioned to its proper location by cycling the BSP type over its full stroke length.
- ④ BSPG or BSR type is recommended when it is difficult to readjust the position of the retainer in the BSP type.
- ⑤ Operating temperature  
The maximum operating temperature is 120°C, and continuous operation is possible at temperatures up to 100°C. If the operating temperature exceeds 100°C, consult **IKO** for further information.
- ⑥ Use Precision Linear Slide at speeds lower than 30 m/min.
- ⑦ Precision Linear Slide does not incorporate a mechanical stopper. When over stroke is expected during the operation, prepare a stopper mechanism on the adjoining equipment.
- ⑧ In order to ensure smooth motion of BSP and BSR types, it is recommended to wash out rust preventive oil with a suitable cleaning agent, and reapply a high grade lubricating oil or grease to the raceways before running in.
- ⑨ Perfluoro Polyether grease is applied on the raceways and rack and pinion of BSPG, and a product is packaged by volatile rust preventive sheet.

# Precautions for Mounting

① The reference mounting surface of Precision Linear Slide is the side surface opposite to the **I I K O** mark.

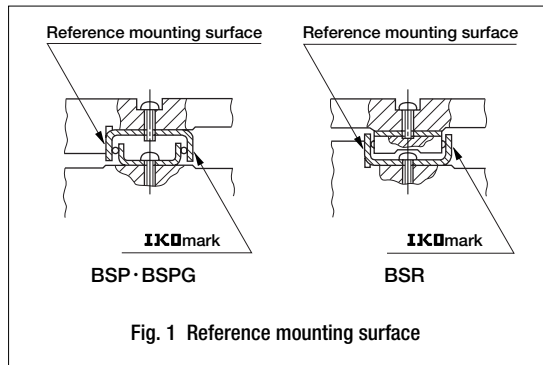

② When mounting Precision Linear Slide, the mounting bolts should not be inserted deeper than the maximum insertion depth shown in the dimension table.

③ When mounting the BSP and BSPG types, the female threads in the table and bed are usually used. It can also be mounted with screws that are one size smaller than the female threads by inserting the screws through the female thread holes. BSP 715 SL ~ BSP 740 SL can not be mounted from inside of the table and bed.

④ When mounting the track rail of BSR type, the female threads of the track rail are used. It can also be mounted with screws that are one size smaller than the female threads by inserting the screws through the female thread holes. BSR 1530 SL and BSR 2040 SL can not be mounted from inside of the track rail. When mounting BSR1230SL to BSR1260SL track rail with screws that are one size smaller than the female threads by inserting the screws through the female thread holes, consult **I I K O**.

⑤ The accuracy of mating surface affects both accuracy and performance of Precision Linear Slides. Therefore, to obtain optimal accuracy during operation, the surface should be finished to as high accuracy as possible. It is recommended to make a relieved fillet at the corner of the mating reference mounting surfaces as shown in Fig. 1. However, corner radius  $R_1$  shown in Table 5 can also be used. Table 5 shows recommended shoulder height of the mating reference mounting surfaces.

Table 5 Shoulder height and corner radius of the mating reference mounting surfaces

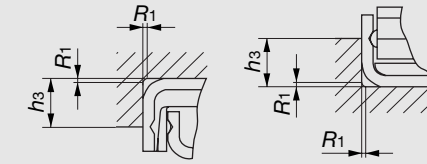

Model number			Shoulder height $h_3$	Corner radius $R_1(\text{max.})$
—	—	<b>BSR 12...</b>	2.5	0.5
<b>BSP 7...</b>	—	—	3	
<b>BSP 10...</b>	—	—	4	
—	<b>BSPG 12...</b>	—	5	
<b>BSP 15...</b>	<b>BSPG 15...</b>	<b>BSR 15...</b>	6	
<b>BSP 20...</b>	<b>BSPG 20...</b>	<b>BSR 20...</b>	6	
<b>BSP 25...</b>	<b>BSPG 25...</b>	<b>BSR 25...</b>	6	

unit : mm

⑥ Tightening torque of mounting bolts affects the performance and accuracy of Precision Linear Slides. The limit of the tightening torque depends on the material, rigidity and finish of the mating surfaces. In general, a light tightening torque is used and the recommended values are shown in Table 6. When vibration is expected to occur, it is recommended to use adhesive agent, etc. to secure the bolts.

Table 6 Recommended tightening torque of bolts

Bolt size	Tightening torque N·m
M2 × 0.4	0.064
M2.3 × 0.4	0.10
M2.6 × 0.45	0.15
M3 × 0.5	0.23

Limited linear motion type : **BSP**

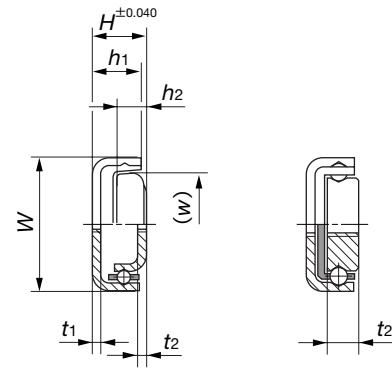
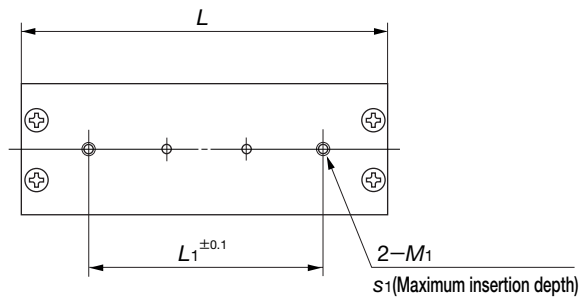

**BSP 7**

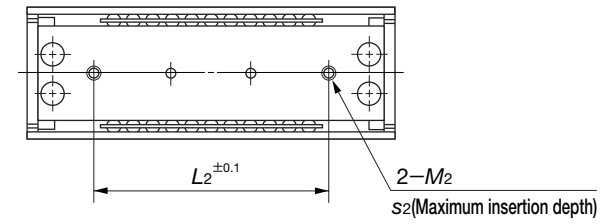
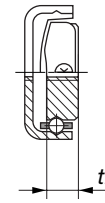

**BSP 10**

Model number	Mass (Ref.) g	Nominal dimensions mm				Mounting dimensions of table mm				
		W	H	L	Maximum stroke length	L <sub>1</sub>	M <sub>1</sub>	Maximum insertion depth S <sub>1</sub>	h <sub>1</sub>	t <sub>1</sub>
BSP 7 15 SL <sup>(1)</sup>	2.1	7	4	15	9	5	M2	1	3.4	0.9
BSP 7 20 SL <sup>(1)</sup>	2.8			20	9	10				
BSP 7 30 SL <sup>(1)</sup>	4.2			30	18	20				
BSP 7 40 SL <sup>(1)</sup>	5.6			40	23	30				
BSP 10 25 SL	6.2	10	6	25	15	15	M2.6	1.5	5.8	1.1
BSP 10 35 SL	8.8			35	26	25				
BSP 10 45 SL	11.3			45	38	35				
BSP 15 30 SL	11	15	8	30	22	14	M3	2.5	7	1.2
BSP 15 40 SL	14.7			40	24	24				
BSP 15 50 SL	18.4			50	32	34				
BSP 15 60 SL	22.1			60	40	40				
BSP 20 40 SL	23.7	20	10	40	22	24	M3	3.2	9	1.4
BSP 20 50 SL	29.7			50	28	34				
BSP 20 60 SL	35.7			60	34	40				
BSP 20 70 SL	41.7			70	40	45				
BSP 20 80 SL	47.6			80	53	50				
BSP 25 50 SL	37.6	25	10	50	26	34	M3	3.5	9	1.6
BSP 25 60 SL	45.3			60	32	40				
BSP 25 70 SL	52.9			70	40	45				
BSP 25 80 SL	60.5			80	51	50				
BSP 25 100 SL	75.8			100	63	60				

Note(1) : BSP715SL to BSP740SL can not be mounted from inside of the table and bed.

Mounting dimensions of bed mm						Basic dynamic load rating	Basic static load rating
w	L <sub>2</sub>	M <sub>2</sub>	Maximum insertion depth S <sub>2</sub>	h <sub>2</sub>	t <sub>2</sub>	C N	C <sub>0</sub> N
3.6	5	M2	2	-	2	93.3	42.0
	10					134	70.0
	20					170	98.0
	30					203	126
6.2	15	M2.6	2.7	3.7	2.7	340	156
	25					398	194
	35					453	233
11.2	14	M3	3	4.5	1.2	395	194
	24					550	311
	34					644	389
	40					732	467
16	24	M3	3.5	6.2	1.4	726	386
	34					866	496
	40					998	606
	45					1 120	717
	50					1 180	772
20.5	34	M3	3	5.7	1.6	866	496
	40					998	606
	45					1 120	717
	50					1 180	772
	60					1 410	992

## Built-in rack & pinion type : BSPG

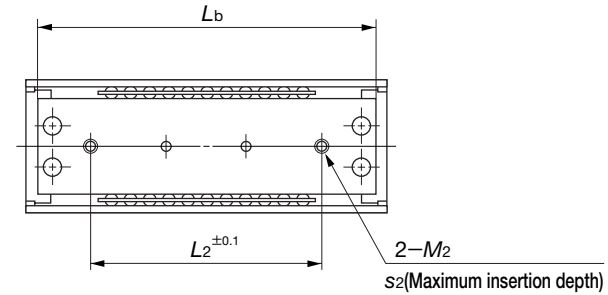
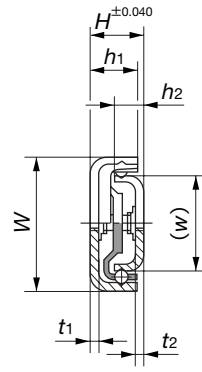
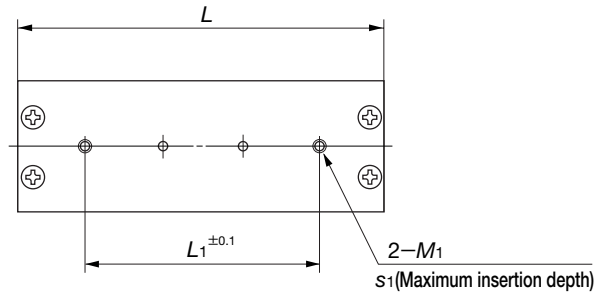

Model number	Mass (Ref.) g	Nominal dimensions mm				Mounting dimensions of table mm				
		W	H	L	Maximum stroke length	L <sub>1</sub>	M <sub>1</sub>	Maximum insertion depth S <sub>1</sub>	h <sub>1</sub>	t <sub>1</sub>
BSPG 12 25 SL	6.5	12	6	25	14	15	M2.6	2	5.2	1.2
BSPG 12 35 SL	9.0			35	24	24				
BSPG 12 45 SL	11.6			45	34	34				
BSPG 15 40 SL	15.8	15	8	40	24	24	M3	2.5	7	1.2
BSPG 15 50 SL	19.6			50	32	34				
BSPG 15 60 SL	23.5			60	40	40				
BSPG 20 40 SL	25.5	20	10	40	22	24	M3	3.2	9	1.4
BSPG 20 50 SL	31.8			50	28	34				
BSPG 20 60 SL	38.1			60	34	40				
BSPG 20 70 SL	44.4			70	40	45				
BSPG 20 80 SL	50.5			80	47	50				
BSPG 25 50 SL	40.3	25	10	50	26	34	M3	3.5	9	1.6
BSPG 25 60 SL	48.3			60	32	40				
BSPG 25 70 SL	56.2			70	38	45				
BSPG 25 80 SL	64.1			80	44	50				
BSPG 25 100 SL	80.0			100	56	60				

Mounting dimensions of bed mm							Basic dynamic load rating	Basic static load rating
L <sub>b</sub>	w	L <sub>2</sub>	M <sub>2</sub>	Maximum insertion depth S <sub>2</sub>	h <sub>2</sub>	t <sub>2</sub>	C N	C <sub>0</sub> N
23.6	7.6	15	M2.6	2	3	1	244	131
33.6		24					299	175
43.6		34					350	219
37	9.6	24	M3	3	4.5	1.2	550	311
47		34					644	389
57		40					732	467
37	13.8	24	M3	3.5	6.2	1.4	726	386
47		34					866	496
57		40					998	606
67		45					1 120	717
77		50					1 240	827
46	18.4	34	M3	3	5.7	1.6	866	496
56		40					998	606
66		45					1 120	717
76		50					1 240	827
96		60					1 460	1 050

Endless linear motion type : BSR

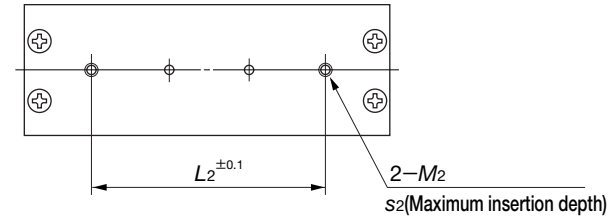
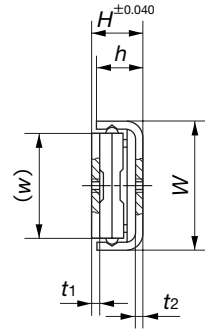
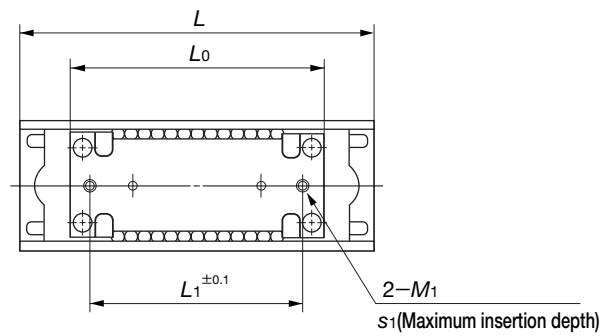

Model number	Mass (Ref.) g	Nominal dimensions mm				Mounting dimensions of slide unit mm					
		W	H	L	Maximum stroke length	w	L <sub>0</sub>	L <sub>1</sub>	M <sub>1</sub>	Maximum insertion depth s <sub>1</sub>	t <sub>1</sub>
BSR 12 30 SL <sup>(1)</sup>	5.8	12	4.5	30	13	9.8	21.5	15	M2	1.3	0.9
BSR 12 40 SL <sup>(1)</sup>	7.0			40	23						
BSR 12 50 SL <sup>(1)</sup>	8.2			50	33						
BSR 12 60 SL <sup>(1)</sup>	9.3			60	43						
BSR 15 30 SL <sup>(2)</sup>	12.6	15	8	30	10	12.2	30	24	M3	1.8	1
BSR 15 40 SL	14.8			40	20						
BSR 15 50 SL	17.1			50	30						
BSR 15 60 SL	19.3			60	40						
BSR 20 40 SL <sup>(2)</sup>	27.6	20	10	40	12	16.8	40	32	M3	2.2	1.4
BSR 20 50 SL	31.1			50	22						
BSR 20 60 SL	34.6			60	32						
BSR 20 70 SL	38.1			70	42						
BSR 20 80 SL	41.6			80	52						
BSR 25 70 SL	53.8	25	10	70	33	21.4	50	42	M3	2.4	1.6
BSR 25 80 SL	58.4			80	43						
BSR 25 100 SL	67.4			100	63						

Mounting dimensions of track rail mm					Basic dynamic load rating	Basic static load rating
L <sub>2</sub>	M <sub>2</sub>	Maximum insertion depth s <sub>2</sub>	h	t <sub>2</sub>	C N	C <sub>0</sub> N
15	M2	1.6	4	0.9	214	140
20						
34						
40						
14	M3	3	7	1.2	543	311
24						
34						
40						
24	M3	3.5	9	1.4	921	551
34						
40						
45						
50						
45	M3	3.5	9	1.6	1 170	772
50						
60						

Note<sup>(1)</sup> : When mounting a track rail for sizes BSR1230SL to BSR1260SL by fixing bolts through the inside of M<sub>2</sub> mounting holes, consult **IKO**.  
<sup>(2)</sup> : BSR1530SL and BSR2040SL can not be mounted by bolts from the inside of track rail due to stroke length limitation.



# Linear Bushings

Description of each series and Table of dimensions

## Linear Bushing G

Page E-120 to E-129



## Linear Bushing

Page E-130 to E-173



## Compact Linear Bushing



Page E-174 to E-177



## Miniature Linear Bushing

Page E-178 to E-185



In the table of dimensions, standard products are referred to using identification numbers marked with . The identification numbers marked with  refer to our semi-standard products.

# Linear Bushing G

LMG

**IKO** Linear Bushing G is a high load capacity type linear motion rolling guide which achieves endless linear motion of an external cylinder along a shaft with grooved raceways. It is a very simple and compact linear bushing with a large load capacity.

## Interchangeable

The dimensional accuracy of the external cylinder and that of the shaft with grooved raceways are controlled individually to ensure interchangeability, so that they can be combined, added or exchanged freely.

## Solid shaft and hollow shaft

The shaft with grooved raceways can be selected from two types: the solid shaft type LMG and the hollow shaft type LMGT. The hollow shaft type is suitable for applications in which piping, wiring or ventilation is needed.

## High load capacity

Two rows of steel balls are incorporated in the external cylinder and make contact with grooved raceways of the shaft to obtain high rigidity and high load capacity.

## Dimensionally interchangeable with Linear Bushing LM

Linear Bushing G is dimensionally interchangeable with Linear Bushing LM and it is easy to change from one to another.

U.S. PATENT No.5,893,646

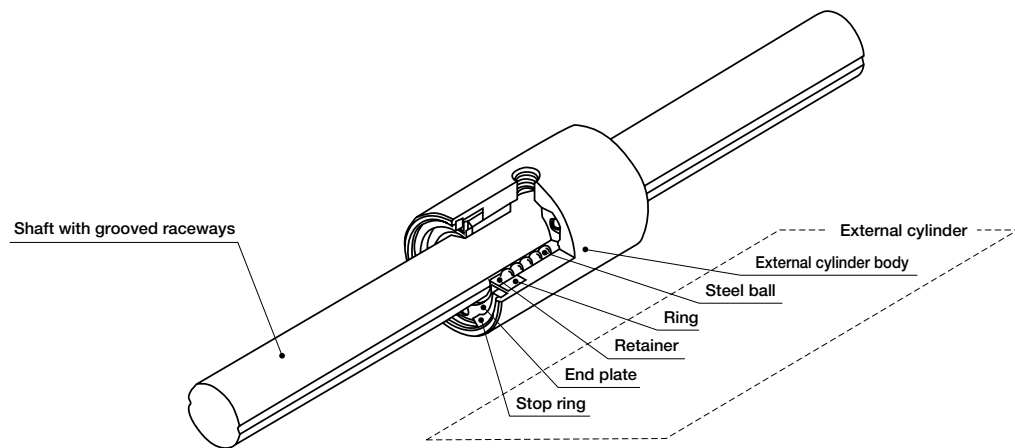

Structure of Linear Bushing G

## Linear Bushing G series

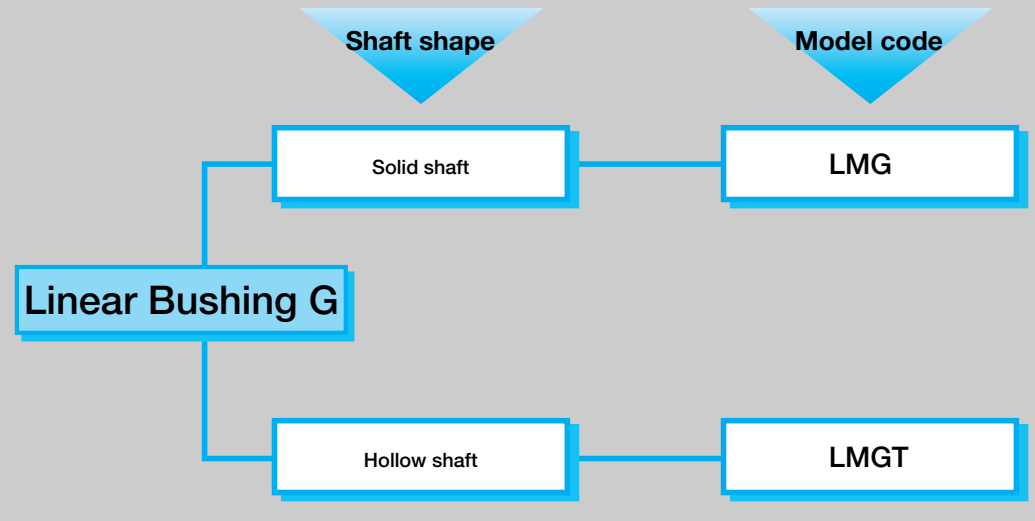

## Identification number and specification

The specification of Linear Bushing G is indicated by the identification number, consisting of a model code, a size, a part code and any supplemental codes.

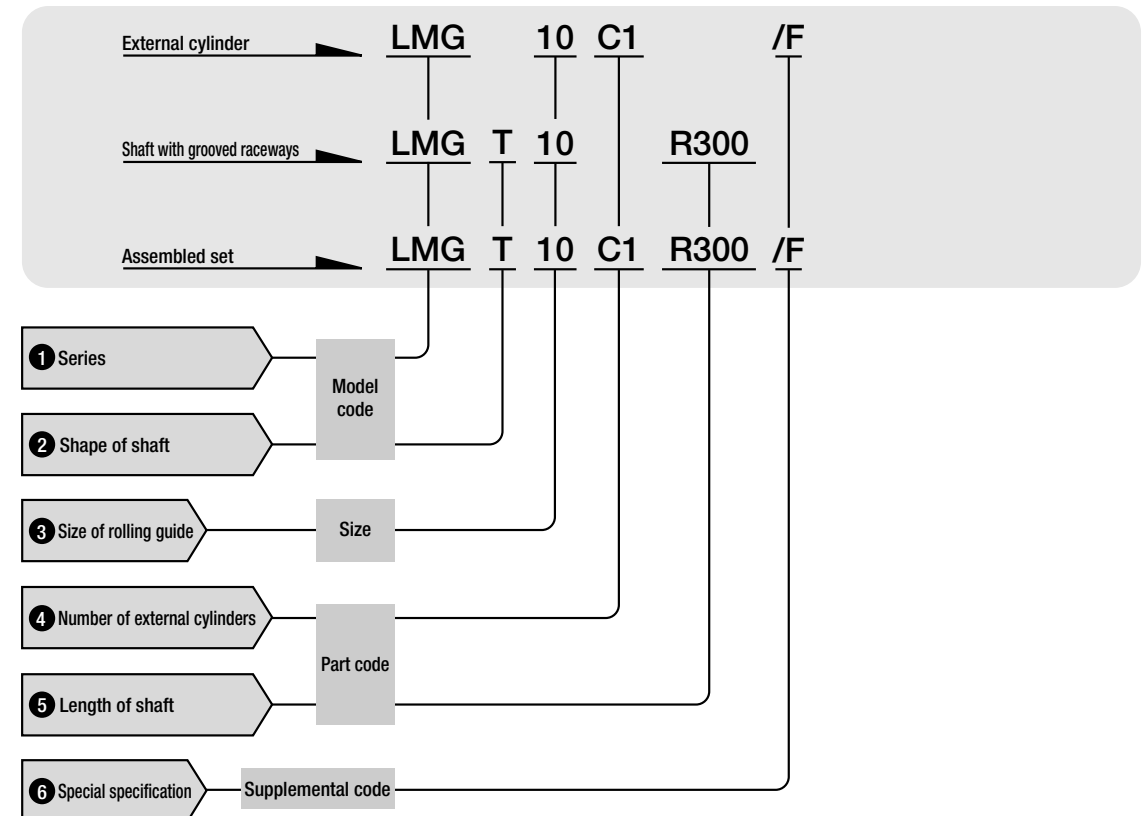

<b>1</b> Series	LMG	
<b>2</b> Shape of shaft	Solid shaft : No symbol	Hollow shaft : T
<b>3</b> Size of rolling guide	Indicate the shaft diameter in mm.	
<b>4</b> Number of external cylinders	Assembled set : C○	External cylinder only : C1
<b>5</b> Length of shaft	Assembled set : R○	Shaft only : R○

For an assembled set, indicate the number of external cylinders assembled on one shaft with grooved raceways. For an external cylinder, only "C1" can be indicated.

Indicate the length of shaft with grooved raceways in mm. For standard and maximum lengths, see the table of dimensions.

<b>6</b> Special specification	External cylinder with shell type flange : F	With end seals : U	Special specification is applicable to all models and sizes. When a combination of several special specifications is required, arrange their supplemental codes in alphabetical order.
--------------------------------	--	--------------------	--

### External cylinder with shell type flange /F

When a flanged external cylinder is required, this type can be used. A shell type flange is formed by precision drawing of thin steel plate.

Table 1 Dimensions of the external cylinder with shell type flange

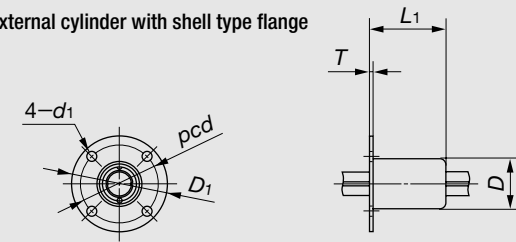

unit : mm

Model number		D	L1	T	D1	d1	pcd
LMG 6	LMGT 6	14	20.5	1.1	28	3.4	22
LMG 8	LMGT 8	17	25.5	1.1	32	3.4	26
LMG 10	LMGT 10	21	30.5	1.1	39	4.5	31
LMG 13	LMGT 13	25	33.5	1.1	43	4.5	35
LMG 16	LMGT 16	30	38.5	1.1	48	4.5	40
LMG 20	LMGT 20	34	43.5	1.1	55	5.5	45

### With end seals /U

To prevent intrusion of foreign matter, end seals are mounted at both ends of the external cylinder.

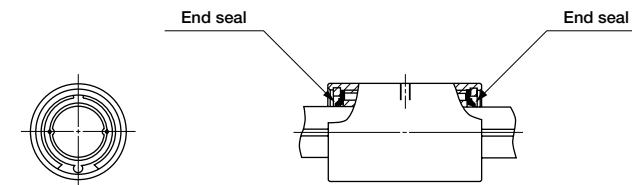

## Load Rating

The load ratings of Linear Bushing G are defined for downward load. Summarized descriptions of load ratings are given below. For details of load rating definitions and load calculations, see "General description".

### Basic dynamic load rating $C$

The basic dynamic load rating is defined as the constant load both in direction and magnitude under which a group of identical Linear Bushings G are individually operated and 90% of the units in the group can travel  $50 \times 10^3$  meters free from material damage due to rolling contact fatigue.

### Basic static load rating $C_0$

The basic static load rating is defined as the static load that gives a prescribed constant contact stress at the center of the contact area between the rolling element and raceway receiving the maximum load.

### Dynamic torque rating $T$

The dynamic torque rating is defined as the constant torque both in direction and magnitude under which a group of identical Linear Bushings G are individually operated and 90% of the units in the group can travel  $50 \times 10^3$  meters free from material damage due to rolling contact fatigue.

### Static torque rating $T_0$

The static torque rating is defined as the static torque that gives a prescribed constant contact stress at the center of the contact area between the rolling element and raceway receiving the maximum load.

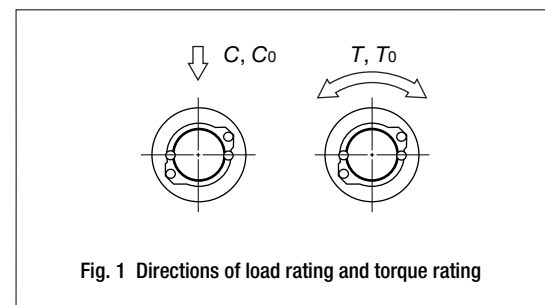

### Load direction and load rating

Since the load ratings of Linear Bushing G given in the table of dimensions are for downward load, they must be corrected for the load direction for upward or lateral load. The corrected basic dynamic load ratings and basic static load ratings are shown in Table 2.

Table 2 Load direction and load rating

Load rating	Dynamic load rating	Static load rating
Downward	$C$	$C_0$
Upward	$C$	$C_0$
Lateral	$1.43C$	$1.73C_0$

## Accuracy

The accuracy of Linear Bushing G is shown in the dimension table. The allowable value for the total radial runout of axial line of the shaft with grooved raceways is shown in Table 3. The allowable value for the twist of grooves with respect to effective length of shaft with grooved raceways is  $33 \mu\text{m}$  for any length of 100 mm over the entire effective length of raceway. Measuring methods of accuracy are shown in Table 4.

Table 3 Total radial runout of axial line of shaft with grooved raceways

unit:  $\mu\text{m}$

Overall length of shaft mm	LMG 6 LMGT 6	LMG 8 LMGT 8	LMG 10 LMGT 10	LMG 13 LMGT 13	LMG 16 LMGT 16	LMG 20 LMGT 20
-	200	142	142	129	129	126
200	315	203	203	153	153	141
315	400	-	255	173	173	153
400	500	-	306	193	193	165
500	630	-	-	221	221	182
630	800	-	-	-	260	207
800	1 000	-	-	-	-	240

Remark: These values are applicable when the radial internal clearance is  $0 \mu\text{m}$ .

Table 4 Measuring methods of accuracy

Item	Measuring method	Illustrations of measuring method
Twist of grooves with respect to effective length of the shaft with grooved raceways	Fix and support the shaft. Then apply a uni-directional torsional moment on the external cylinder before placing a dial gage probe at right angles to the shaft against the side face of the measuring block attached on the external cylinder. Measure runout when the external cylinder and the gage have traveled together 100 millimeters on any effective part of the raceway grooves. In the measurement, the probe should be applied as near as possible to the outer surface of the external cylinder.	<p>Measuring block</p> <p>100</p> <p>Datum block for traveling of gage</p>
Total radial runout of axial line of shaft with grooved raceways (See Table 3.)	While supporting the shaft at its supporting parts or at both center holes, place a dial gage probe to the outer surface of external cylinder, and measure runout at several positions in the axial direction while turning the shaft one rotation. Use the maximum value.	

## Radial Internal Clearance

The radial internal clearance of Linear Bushing G is approx.  $10\mu\text{m}$ . In the shell flange type, radial internal clearance is slightly smaller than that of standard type.

## Moment of Inertia of Sectional Area and Section Modulus of Shaft with Grooved Raceways

Moment of inertia of sectional area and section modulus of the shaft with grooved raceways are shown in Table 5.

Table 5 Moment of inertia of sectional area and section modulus

Model number		Moment of inertia of sectional area $\text{mm}^4$		Section modulus $\text{mm}^3$	
		Solid shaft	Hollow shaft	Solid shaft	Hollow shaft
LMG 6	LMGT 6	60	59	20	20
LMG 8	LMGT 8	190	190	49	48
LMG 10	LMGT 10	470	460	95	93
LMG 13	LMGT 13	1 360	1 300	210	200
LMG 16	LMGT 16	3 130	2 930	390	360
LMG 20	LMGT 20	7 720	7 230	770	720

## Precautions for Use

### 1 Lubrication

Both grease and oil lubrication are applicable. In case of grease lubrication, use of quality lithium-soap base grease is recommended for general applications.

### 2 Fixing depth of mounting bolt of external cylinder

The fixing depth of mounting bolt of external cylinder should be less than the maximum depth shown in the dimension table. The fixing female thread hole in the external cylinder is a through hole. Therefore, if the fixing depth of mounting bolt is too large, the mounting bolt will contact and push the shaft, and accuracy and life will be affected adversely.

### 3 Multiple external cylinders in close distance

When two or more external cylinders (standard or with shell type flange) are used in close distance in the same housing, the distance between the centers of external cylinders should be over three times of the length of external cylinders. If the external cylinders are used in close distance, consult **IKO**.

### 4 Operation with rotational torque

In case a bi-directional and/or repeated rotational torque is applied, select **IKO** Linear Ball Spline G.

## Precautions for Mounting

### ● Fit

The normal fit between the external cylinder of Linear Bushing G and the housing is recommended to be a clearance fit (H7). But, in special cases, a transition fit (J7) may be used. In case of the external cylinder with shell type flange, a clearance of over 0.2 mm based on the nominal outside diameter is required.

### ● Mounting

To mount Linear Bushing G, the external cylinder should be press fitted carefully with proper tools using, for example, a press machine. Mounting examples are shown in Fig. 2.

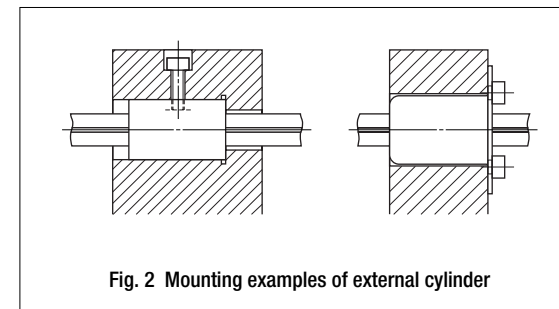

Fig. 2 Mounting examples of external cylinder

## Accessories

### ● Shaft Support Block

Support blocks are prepared for supporting the ends of "shaft with grooved raceways" of Linear Bushing G. For details, consult **IKO**.

Solid shaft : LMG  
Hollow shaft : LMGT

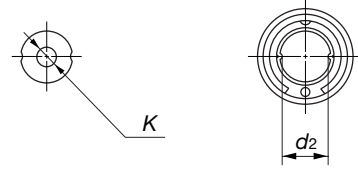

Bore dia. of hollow shaft

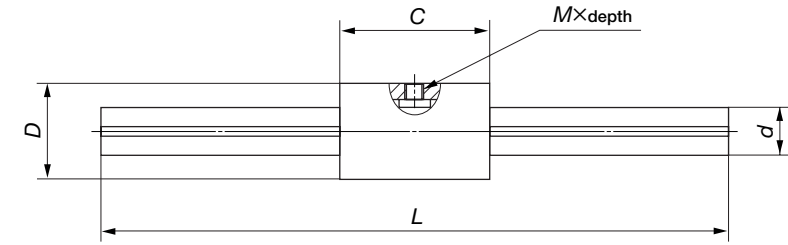

Model number	Interchangeable	Mass (Ref.) g		Nominal dimensions and tolerances mm						
		External cylinder	Shaft <sup>(1)</sup>	D	Tolerance	C	Tolerance	M×depth <sup>(2)</sup>	d	Tolerance
LMG 6	☆	9.4	22.0	12	0 -0.011	19	0 -0.200	M2.5×1.9 (2.5)	6	0 -0.012
LMGT 6	☆		19.5							
LMG 8	☆	15.7	39.3	15	0 -0.011	24	0 -0.200	M3 ×2.4 (3)	8	0 -0.015
LMGT 8	☆		33.7							
LMG 10	☆	31.5	61.2	19	0 -0.013	29	0 -0.200	M3 ×3.1 (4)	10	0 -0.015
LMGT 10	☆		51.4							
LMG 13	☆	45.4	104	23	0 -0.013	32	0 -0.200	M3 ×3.4 (4.5)	13	0 -0.018
LMGT 13	☆		81.4							
LMG 16	☆	78.2	157	28	0 -0.013	37	0 -0.200	M4 ×4.1 (5.5)	16	0 -0.018
LMGT 16	☆		118							
LMG 20	☆	110	246	32	0 -0.016	42	0 -0.200	M4 ×4.1 (5.5)	20	0 -0.021
LMGT 20	☆		185							

Note<sup>(1)</sup> : Figures shown in this column are the mass per 100 mm of shaft.

<sup>(2)</sup> : The values in parentheses indicate the max. fixing depth of mounting bolt.

<sup>(3)</sup> : Dimension  $d_2$  indicates the maximum diameter when machining is done at the shaft ends.

<sup>(4)</sup> : Figures shown in  $T$  and  $T_0$  columns are applicable when a uni-directional torque is applied.

In case a bi-directional and/or repeated rotational torque is applied, select **IKO** Linear Ball Spline G.

Remark : All Linear Bushing G series are interchangeable specification products.

$d_2$ <sup>(3)</sup>	K	L	Maximum length	Basic dynamic load rating	Basic static load rating	Dynamic torque rating <sup>(4)</sup>	Static torque rating <sup>(4)</sup>
				C N	$C_0$ N	T N·m	$T_0$ N·m
5.2	-	150 200	300	587	641	2.1	2.2
	2						
7	-	150 200 250	500	769	962	3.5	4.3
	3		400				
8.9	-	200 300	600	1 410	1 710	8.0	9.7
	4						
11.9	-	200 300 400	800	1 880	2 150	13.7	15.7
	6						
14	-	200 300 400	1 000	2 590	2 930	23.1	26.1
	8						
17.5	-	300 400 500 600	1 000	3 010	3 660	32.8	39.9
	10						

# Linear Bushing

LBE/LBD/LBB/LM/LME/LMB

**IKO Linear Bushing** is a high precision linear motion rolling guide which travels along a shaft to achieve endless linear motion. In the external cylinder, a retainer, steel balls, etc. are compactly incorporated. Wide variations in size are available for selections suitable for each application.

## Low frictional linear motion

Steel balls are accurately guided by a retainer, so low frictional resistance and stable linear motion can be achieved.

## Wide variations

For each dimensional series, standard, adjustable clearance and open types are available with and without seals, so the best linear bushing for the application may be selected.

## Simple replacement of conventional plain bushings

It is easy to use Linear Bushings instead of conventional plain bushings, because both types are used with a round shaft, and no major redesign is necessary.

## Stainless steel type

Linear Bushings made of stainless steel are also available. This type is suitable for applications where corrosion resistance is important.

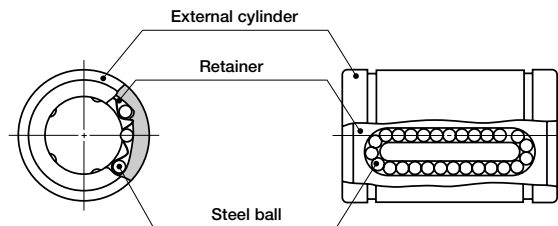

Structure of Linear Bushing

## Linear Bushing series

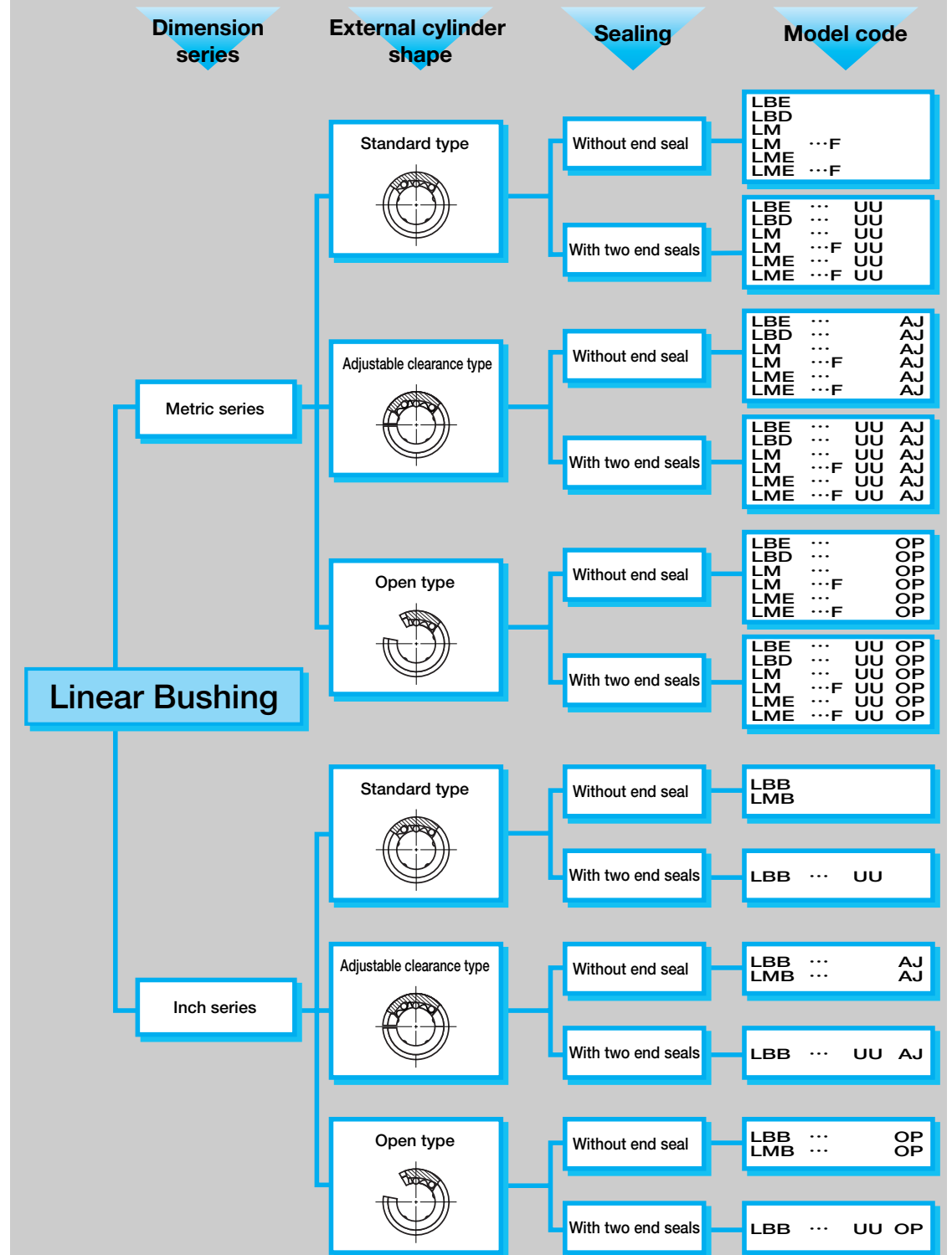

Remark : "F" in the model code indicates that it is stainless steel type.

LBE, LBD, LBB, LM, LME, LMB

## ● Identification number and specification

The specification of Linear Bushing is indicated by the identification number, consisting of a model code, a size, a material symbol, a part code, a shape code and a classification symbol.

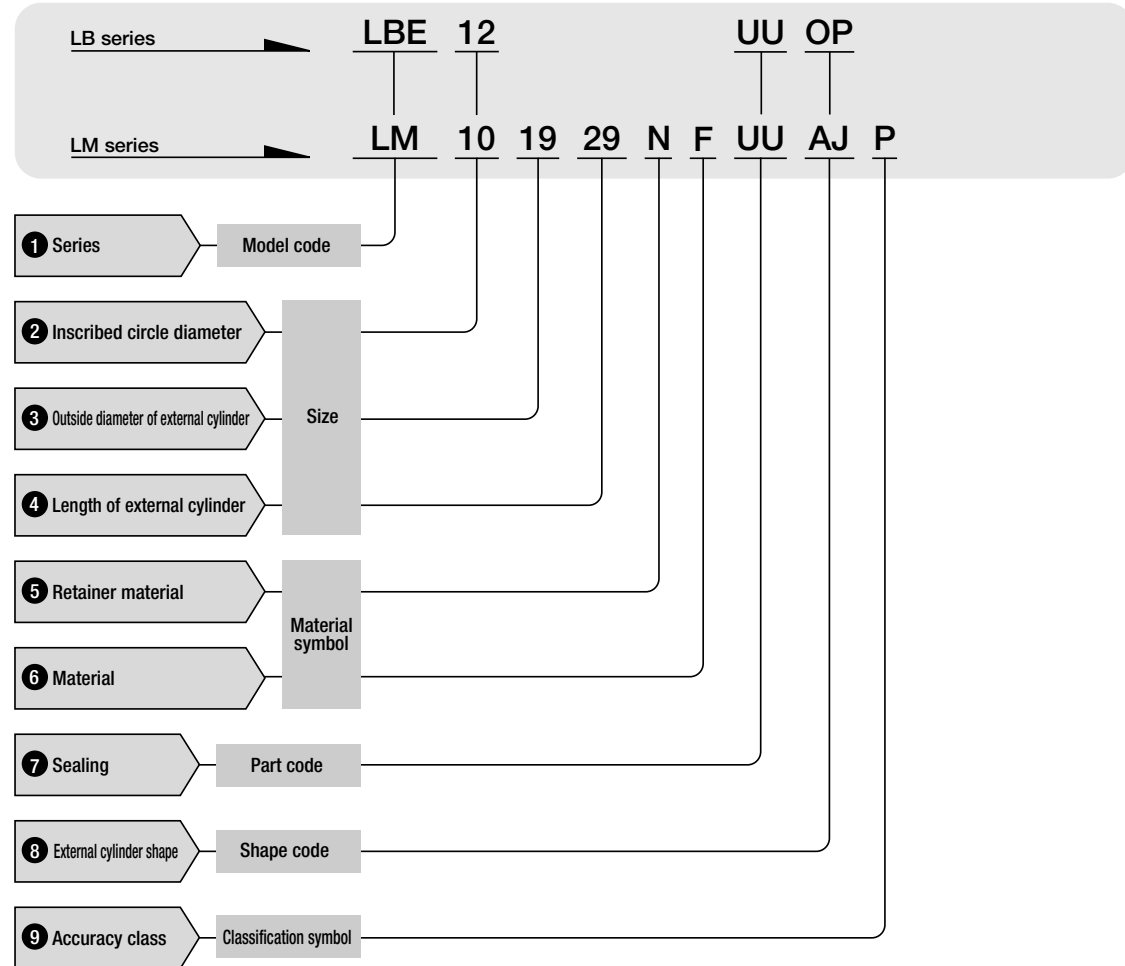

<b>1 Series</b>	Metric series	: LBE, LBD, LM, LME
	Inch series	: LBB, LMB

<b>2 Incribed circle diameter</b>	For the metric series, indicate the inscribed circle diameter in mm. For the inch series, indicate the inscribed circle diameter in the unit of 1/16 inch.
-----------------------------------	--

<b>3 Outside diameter of external cylinder</b>	For the metric series, indicate the outside diameter of external cylinder in mm. For the inch series, indicate the outside diameter of external cylinder in the unit of 1/16 inch.
--	--

<b>4 Length of external cylinder</b>	For the metric series, indicate the length of the external cylinder in mm. For the inch series, indicate the length of external cylinder in the unit of 1/16 inch.
--------------------------------------	--

<b>5 Retainer material</b>	Carbon steel made	: No symbol	In case of LM series, specify the retainer material. For applicable models and sizes, see the "Model number" column in the table of dimensions on pages E-140 to E-173. The maximum operating temperature for the synthetic resin type is 100°C. Continuous operation is possible at temperatures up to 80°C. In all of LB series, the retainer is made of synthetic resin.
	Synthetic resin made	: N	

<b>6 Material</b>	High carbon steel made	: No symbol	Specify the component part material. For applicable models and sizes, see the "Model number" column in the table of dimensions on pages E-140 to E-173.
	Stainless steel made	: F	

<b>7 Sealing</b>	Without end seal	: No symbol	The two seal types incorporate seals with superior dust protection performance at both ends of the external cylinder for preventing intrusion of foreign matter. The maximum allowable temperature for seals is 120°C.
	With two end seals	: UU	

<b>8 External cylinder shape</b>	Standard type	: No symbol	See "External cylinder shape" shown below.
	Adjustable clearance type	: AJ	
	Open type	: OP	

**External cylinder shape**

**Standard type**  
This type is widely used as a general purpose linear guide. High and precision classes are available.

**Adjustable clearance type**  
A slot in a longitudinal direction is made on the external cylinder in order to adjust the clearance. When this type is used with a housing which can adjust the bore diameter, the radial internal clearance can be adjusted without fit selection between the linear bushing and shaft. It is possible to give a preload.

**Open type**  
This type has one or two fewer ball circuits than the standard type, creating an open section to allow clearance for a shaft support. The open type bushing is commonly used with long shafts when one or more support blocks are needed to reduce shaft deflection or sag. The width of the support blocks can be determined to match the (E) dimension of fan shaped open section shown in the table of dimensions. The radial internal clearance can also be adjusted.

<b>9 Accuracy class</b>	High	: No symbol	For details of accuracy, see the table of dimensions on pages E-140 to E-173. High class and precision class are available for the LBD, LBB, LM and LMB standard type series. For the adjustable clearance type and the open type, only high class is available, and the accuracy values are applicable only before cutting the external cylinders.
	Precision	: P	



# Load Rating

Summarized descriptions of load ratings of Linear Bushing are given below. For details of load rating definitions and load calculations, see "General description".

## Basic dynamic load rating $C$

The basic dynamic load rating is defined as the constant load both in direction and magnitude under which a group of identical Linear Bushings are individually operated and 90% of the units in the group can travel  $50 \times 10^3$  meters free from material damage due to rolling contact fatigue.

## Basic static load rating $C_0$

The basic static load rating is defined as the static load that gives a prescribed constant contact stress at the center of the contact area between the rolling element and raceway receiving the maximum load.

## Relationships between load ratings and the position of ball circuits

Load ratings of Linear Bushing are affected by the position of the ball circuits. In the table of dimensions, two types of load ratings are shown corresponding to the load directions and steel ball circuit positions as shown in Fig. 1 and Fig. 2.

In Fig. 1 the load direction is in line with the steel ball circuit position and this direction is referred to as load direction A in the table of dimensions. In general, the load ratings for this direction are also used, when the load direction is indeterminate or the steel ball circuit position in relation to the load direction cannot be determined.

In Fig. 2, the load direction is pointed at the center of two ball circuits and this direction is referred to as load direction B in the table of dimensions. In general, a larger load can be received in this case compared with load direction A.

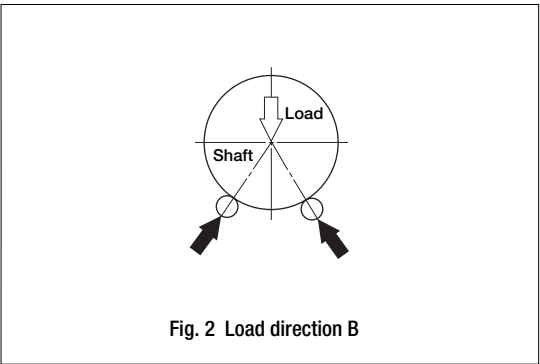
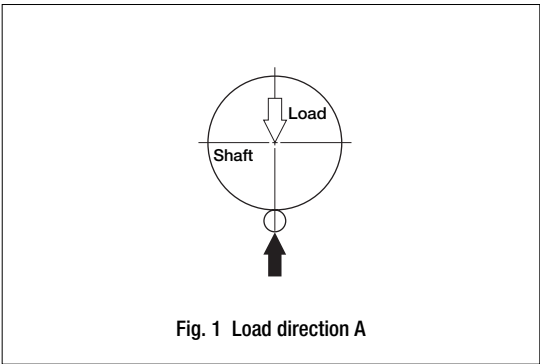

# Precautions for Use

## 1 Clearance

Adjustable clearance and open type Linear Bushings can be adjusted for radial internal clearance if they are used with a housing which can adjust the bore diameter.

However, if the degree of the adjustment is excessive, deformation at the contact points between steel balls and shaft or external cylinder becomes large, resulting in short life. Therefore, it is recommended to prepare a shaft with a specified fit tolerance and adjust the radial internal clearance to zero or minimal preload by matching the individual components.

The clearance is adjusted while checking with a dial gage. The adjustment is generally completed when the shaft is rotated in an unloaded condition and light resistance is caused by the rotation of shaft. In this condition, the radial internal clearance becomes zero or minimal preload. For open type Linear Bushings having three rows of ball circuits, clearance adjustment can not be made.

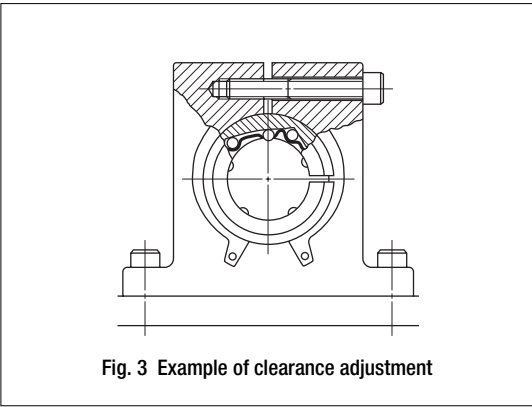

## 2 Raceway surface

Since Linear Bushings operate with a shaft as a raceway surface, the shaft should be heat-treated and ground. Recommended surface hardness and roughness of the shaft are shown in Table 1, and also recommended minimum effective hardening depth of the raceway is shown in Table 2.

Table 1 Surface hardness and roughness of raceway

Item	Recommended value	Remarks
Surface hardness	58~64HRC	When the raceway hardness is less than the necessary hardness, multiply load ratings by the hardness factor.
Surface roughness	0.2 $\mu$ mRa or better (0.8 $\mu$ mRy or better)	When the required accuracy is not severe, a surface roughness of about 0.8 $\mu$ mRa (3.2 $\mu$ mRy) is adequate.

Table 2 Minimum effective hardening depth unit : mm

Shaft diameter		Recommended minimum effective hardening depth
over	incl.	
-	28	0.8
28	50	1.0
50	100	1.5
100	150	2.0

**3 Lubrication**

Linear Bushings can be used with oil or grease lubrication. A good quality lithium-soap base grease is recommended for grease lubrication.

**4 When rotational motion is present**

Linear Bushings can only be operated in linear motion and can not be rotated. When linear motion in short stroke length and rotation are both required, **IKO** Stroke Rotary Bushing (See page E-176.) is recommended. If linear motion in long stroke length and rotation are both required, a combination of Linear Bushing and **IKO** Needle Roller Bearing as shown in Fig. 4 is recommended.

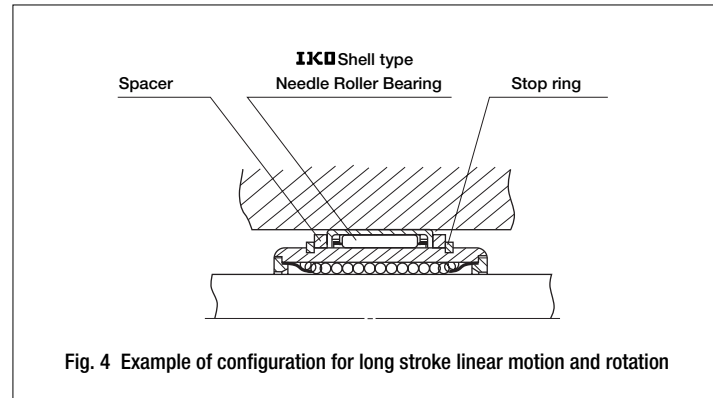

Fig. 4 Example of configuration for long stroke linear motion and rotation

**5 Precaution for use of Open type Linear Bushing having three rows of ball circuits**

Open type Linear Bushings having three rows of ball circuits can be used only for the load direction shown in Fig. 5. If two Linear Bushings are used in parallel, by considering the load distribution, the arrangement shown in Fig. 6 is recommended. This type can not be adjusted for radial internal clearance.

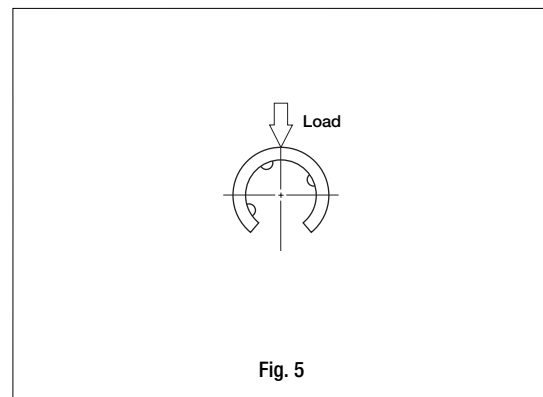

Fig. 5

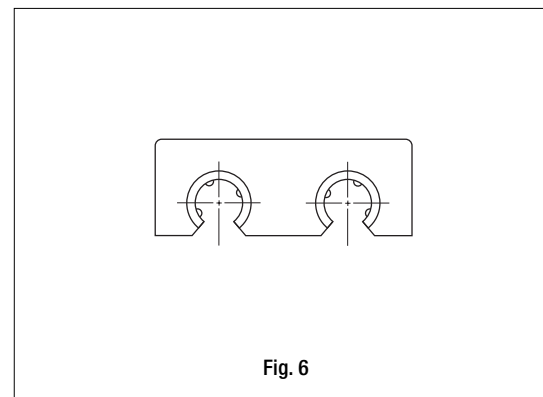

Fig. 6

**Precautions for Mounting**

**Fit**

Table 3 shows the recommended fit tolerances for Linear Bushing. The fit between Linear Bushing and housing is usually clearance fit. For some special applications, an interference fit may be required. For adjustable clearance or open type Linear Bushings, the following recommendations apply. The shaft diameter is finished smaller than the lower limit of the tolerance range of the inscribed circle diameter of the Linear Bushing, while the housing diameter is finished larger than the upper limit of the tolerance range of the outside diameter of the external cylinder of the Linear Bushing.

Table 3 Recommended fit tolerance

Type	Item	Shaft		Housing	
		Normal clearance	Closer clearance	Clearance fit	Interference fit
LBD, LBB	High class	f6,g6	h6	H7	J7
LM, LMB	Precision class	f5,g5	h5	H6	J6
LBE, LME	-	h6	j6	H7	J7

**Mounting**

When press-fitting the Linear Bushing into the housing, do not hit the end plate. The correct method is to gradually push the external cylinder with a jig for assembling. (See Fig. 7.) Then the external cylinder is fixed in the axial direction with a stop ring or a stopper plate. When inserting the shaft into the Linear Bushing assembled into a housing, gradually and gently insert a shaft avoiding to give impact on the steel balls and retainers.

If two shafts are used in parallel, fix one shaft accurately as a datum shaft and locate the second shaft to the datum shaft keeping the parallelism. Fig. 8 shows an example of general assembling.

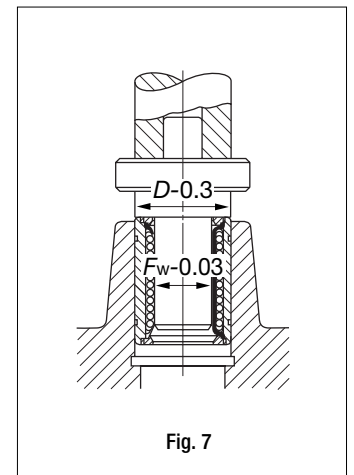

Fig. 7

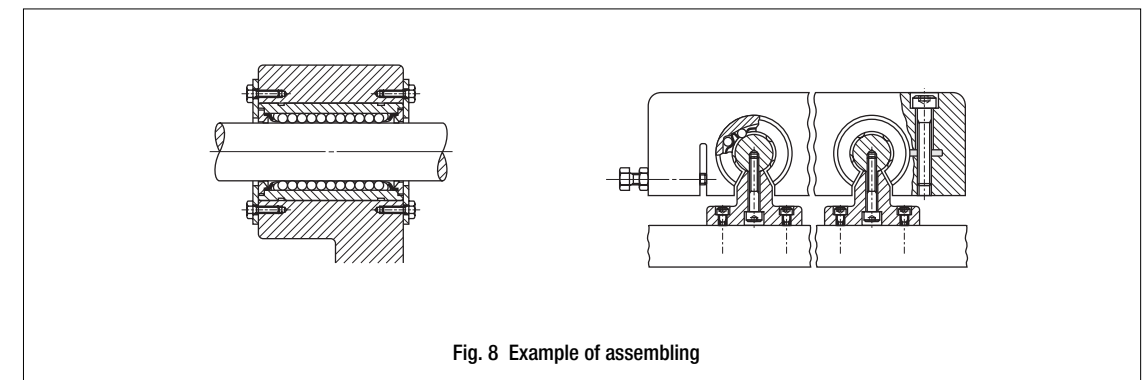

Fig. 8 Example of assembling

## Accessories

### ● Steel shaft for Linear Bushing

In order to achieve full performance of Linear Bushing, heat-treated and ground steel shafts with high accuracy are available. Commercial shafts can also be delivered upon request. For details, consult **IKO**.

### ● Shaft support block

Support blocks are prepared for supporting the ends of shaft for Linear Bushing. For details, consult **IKO**.

### ● Felt seals for Linear Bushing

Felt seals are available for Linear Bushing without end seal. If dust protection and minimal frictional resistance in linear motion are both required, felt seals are recommended. Dimensions of felt seals are shown in Table 4.

Table 4 Dimensions of felt seals for Linear Bushing

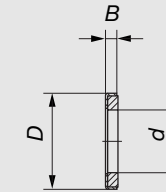

unit : mm

Model number	<i>d</i>	<i>D</i>	<i>B</i>
<b>FLM 6</b>	6	12	2
<b>FLM 8</b>	8	15	2
<b>FLM 10</b>	10	19	3
<b>FLM 13</b>	13	23	3
<b>FLM 16</b>	16	28	4
<b>FLM 20</b>	20	32	4
<b>FLM 25</b>	25	40	5
<b>FLM 30</b>	30	45	5
<b>FLM 35</b>	35	52	5
<b>FLM 40</b>	40	60	5
<b>FLM 50</b>	50	80	10
<b>FLM 60</b>	60	90	10
<b>FLM 80</b>	80	120	10
<b>FLM 100</b>	100	150	10

Remark : These felt seals are used with LM or LBD models. For other models and types, consult **IKO** for details.

# IKO Linear Bushing : Metric series

Standard type : **LBE**      Adjustable clearance type : **LBE...AJ**      Open type : **LBE...OP**

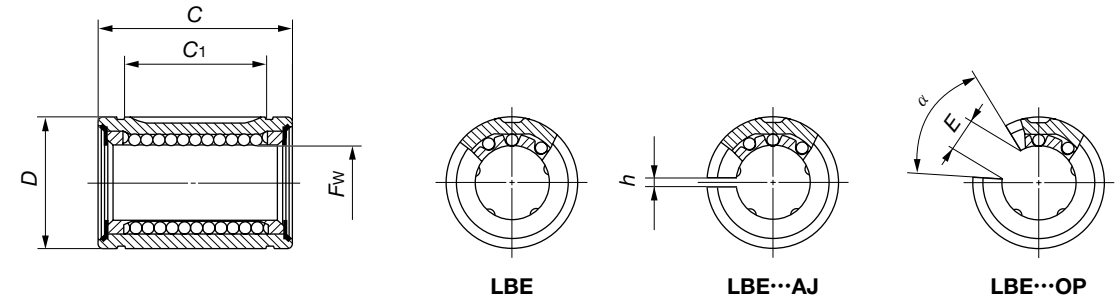

Shaft diameter mm	Standard type	Model number								Fw	Tolerance μm
		Ball circuits	Mass (Ref.) g	Adjustable clearance type	Ball circuits	Mass (Ref.) g	Open type	Ball circuits	Mass (Ref.) g		
5	<b>LBE 5</b>	3	8.6	<b>LBE 5 AJ</b>	3	8.4	—	—	—	5	+8 0
8	<b>LBE 8</b>	3	16.9	<b>LBE 8 AJ</b>	3	16.6	—	—	—	8	
12	<b>LBE 12</b>	4	36.5	<b>LBE 12 AJ</b>	4	35.5	<b>LBE 12 OP</b>	3	29.5	12	+9 -1
16	<b>LBE 16</b>	4	47	<b>LBE 16 AJ</b>	4	46.5	<b>LBE 16 OP</b>	3	37.5	16	
20	<b>LBE 20</b>	5	84.5	<b>LBE 20 AJ</b>	5	83	<b>LBE 20 OP</b>	4	72	20	+11 -1
25	<b>LBE 25</b>	5	161	<b>LBE 25 AJ</b>	5	159	<b>LBE 25 OP</b>	4	141	25	
30	<b>LBE 30</b>	6	305	<b>LBE 30 AJ</b>	6	300	<b>LBE 30 OP</b>	5	265	30	+13 -2
40	<b>LBE 40</b>	6	555	<b>LBE 40 AJ</b>	6	545	<b>LBE 40 OP</b>	5	480	40	
50	<b>LBE 50</b>	6	935	<b>LBE 50 AJ</b>	6	925	<b>LBE 50 OP</b>	5	815	50	

Nominal dimensions and tolerances mm										Eccentricity Max. μm	Basic dynamic load rating C		Basic static load rating C <sub>0</sub>		Preferable circlip DIN 471
D	Tolerance μm	C	Tolerance μm	C <sub>1</sub>	Tolerance μm	h	E	α Degree	Load direction A N		Load direction B N	Load direction A N	Load direction B N		
12	0 -8	22	0 -210	12	+270 0	1.5	—	—	12	90.6	73.6	213	213	12×1	
16	—	25	—	14	—	1.5	—	—		121	98.6	255	255	16×1	
22	0 -9	32	0 -250	20	+330 0	1.5	7.5	78°	13	284	327	575	813	22×1.2	
26	—	36	—	22	—	1.5	10	78°		311	357	587	830	26×1.2	
32	—	45	—	28	—	2.0	10	60°	14	617	734	1 150	1 680	32×1.5	
40	0 -11	58	0 -300	40	+390 0	2.0	12.5	60°	15	1 070	1 270	2 020	2 960	42×1.75	
47	—	68	—	48	—	2.0	12.5	50°		1 560	1 650	3 060	3 910	48×1.75	
62	0 -13	80	0 -350	56	+460 0	2.0	16.8	50°	17	2 710	2 870	4 890	6 250	62×2	
75	—	100	—	72	—	2.0	21	50°		3 940	4 180	7 130	9 120	75×2.5	

# IKO Linear Bushing with Seals : Metric series

Standard type : LBE...UU      Adjustable clearance type : LBE...UU AJ      Open type : LBE...UU OP

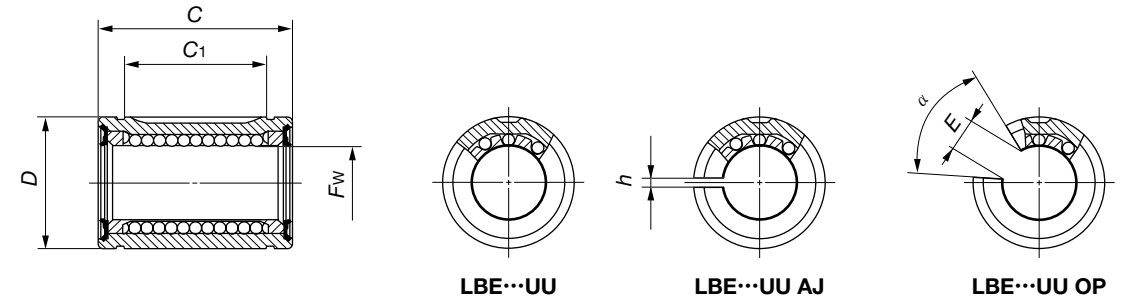

Shaft diameter mm	Standard type	Model number						Fw	Tolerance μm		
		Ball circuits	Mass (Ref.) g	Adjustable clearance type	Ball circuits	Mass (Ref.) g	Open type			Ball circuits	Mass (Ref.) g
5	LBE 5 UU	3	8.6	LBE 5 UU AJ	3	8.4	—	—	5	+ 8 0	
8	LBE 8 UU	3	17	LBE 8 UU AJ	3	16.7	—	—	8		
12	LBE 12 UU	4	36.5	LBE 12 UU AJ	4	36	LBE 12 UU OP	3	29.5	12	
16	LBE 16 UU	4	47.5	LBE 16 UU AJ	4	47	LBE 16 UU OP	3	38	16	+ 9 - 1
20	LBE 20 UU	5	85	LBE 20 UU AJ	5	83.5	LBE 20 UU OP	4	72.5	20	
25	LBE 25 UU	5	162	LBE 25 UU AJ	5	160	LBE 25 UU OP	4	142	25	+11 - 1
30	LBE 30 UU	6	305	LBE 30 UU AJ	6	305	LBE 30 UU OP	5	265	30	
40	LBE 40 UU	6	555	LBE 40 UU AJ	6	550	LBE 40 UU OP	5	485	40	+13 - 2
50	LBE 50 UU	6	940	LBE 50 UU AJ	6	930	LBE 50 UU OP	5	815	50	

Nominal dimensions and tolerances mm										Eccentricity Max. μm	Basic dynamic load rating C		Basic static load rating C <sub>0</sub>		Preferable circlip DIN 471
D	Tolerance μm	C	Tolerance μm	C <sub>1</sub>	Tolerance μm	h	E	α Degree	Load direction A N		Load direction B N	Load direction A N	Load direction B N		
12	0 - 8	22	0 - 210	12	+270 0	1.5	—	—	12	90.6	73.6	213	213	12×1	
16	—	25	—	14	—	1.5	—	—		121	98.6	255	255	16×1	
22	0 - 9	32	0 - 250	20	+330 0	1.5	7.5	78°	13	284	327	575	813	22×1.2	
26	—	36	—	22	—	1.5	10	78°		311	357	587	830	26×1.2	
32	—	45	—	28	—	2.0	10	60°	14	617	734	1 150	1 680	32×1.5	
40	0 - 11	58	0 - 300	40	+390 0	2.0	12.5	60°	15	1 070	1 270	2 020	2 960	42×1.75	
47	—	68	—	48	—	2.0	12.5	50°		1 560	1 650	3 060	3 910	48×1.75	
62	0 - 13	80	0 - 350	56	+460 0	2.0	16.8	50°	17	2 710	2 870	4 890	6 250	62×2	
75	—	100	—	72	—	2.0	21	50°		3 940	4 180	7 130	9 120	75×2.5	

# IKO Linear Bushing : Metric series



Standard type : **LBD**      Adjustable clearance type : **LBD...AJ**      Open type : **LBD...OP**

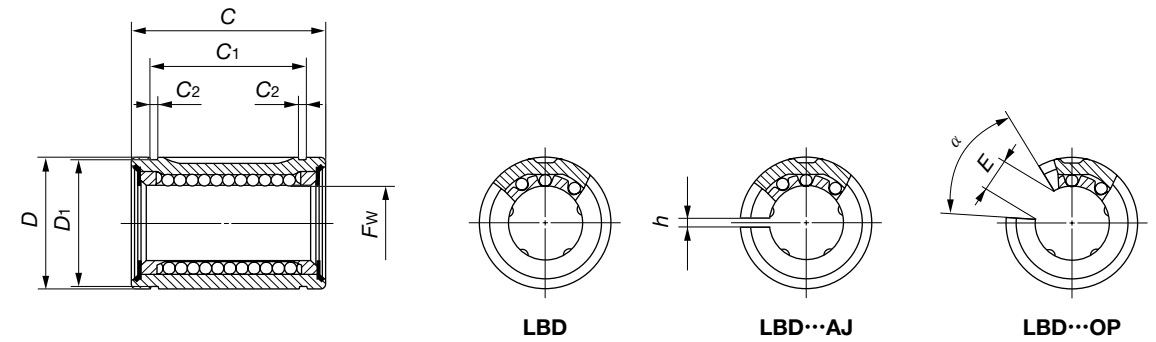

Shaft diameter mm	Standard type	Model number								Fw	Tolerance μm	
		Ball circuits	Mass (Ref.) g	Adjustable clearance type	Ball circuits	Mass (Ref.) g	Open type	Ball circuits	Mass (Ref.) g		Pre- cision	High
6	<b>LBD 6</b>	3	5.1	<b>LBD 6 AJ</b>	3	5.0	—	—	—	6		
8	<b>LBD 8S</b>	3	8.3	<b>LBD 8S AJ</b>	3	8.1	—	—	—	8		
	<b>LBD 8</b>	3	11.8	<b>LBD 8 AJ</b>	3	11.5	—	—	—	8		
10	<b>LBD 10</b>	4	25.5	<b>LBD 10 AJ</b>	4	25	<b>LBD 10 OP</b>	3	20.5	10	0	0
13	<b>LBD 13</b>	4	41.5	<b>LBD 13 AJ</b>	4	40.5	<b>LBD 13 OP</b>	3	33	13		
16	<b>LBD 16</b>	4	58	<b>LBD 16 AJ</b>	4	57	<b>LBD 16 OP</b>	3	47	16		
20	<b>LBD 20</b>	5	80	<b>LBD 20 AJ</b>	5	79	<b>LBD 20 OP</b>	4	69	20		
25	<b>LBD 25</b>	5	160	<b>LBD 25 AJ</b>	5	158	<b>LBD 25 OP</b>	4	142	25	0	0
30	<b>LBD 30</b>	6	220	<b>LBD 30 AJ</b>	6	215	<b>LBD 30 OP</b>	5	196	30		
35	<b>LBD 35</b>	6	320	<b>LBD 35 AJ</b>	6	315	<b>LBD 35 OP</b>	5	280	35		
40	<b>LBD 40</b>	6	440	<b>LBD 40 AJ</b>	6	435	<b>LBD 40 OP</b>	5	390	40	0	0
50	<b>LBD 50</b>	6	1 390	<b>LBD 50 AJ</b>	6	1 380	<b>LBD 50 OP</b>	5	1 220	50	0	0

Note(1) : When circlips are used for mounting, the dimension C<sub>1</sub> minus twice the width of circlip becomes the width of hub.  
Remark : In the tolerance and eccentricity columns, "Precision" refers to precision class and "High" refers to high class.

Nominal dimensions and tolerances mm											Eccentricity		Basic dynamic load rating C		Basic static load rating C <sub>0</sub>	
D	Tolerance μm	C	Tolerance μm	C <sub>1</sub> ( <sup>1</sup> )	Tolerance μm	C <sub>2</sub>	D <sub>1</sub>	h	E	α Degree	Max. μm		Load direction A N	Load direction B N	Load direction A N	Load direction B N
12	0 -11	19	-200	13.5	-200	1.1	11.5	1.5	—	—	8	12	78.0	63.4	155	155
15		17		11.5		1.1	14.3	1.5	—	—			74.7	60.7	128	128
15	0 -13	24	-200	17.5	-200	1.1	14.3	1.5	—	—	8	12	121	98.6	255	255
19		29		22		1.3	18	1.5	7	80°			197	226	405	573
23	0 -13	32	-200	23	-200	1.3	22	1.5	9	80°	8	12	292	336	578	818
28		37		26.5		1.6	27	1.5	11	80°			426	489	766	1 080
32	0 -16	42	-300	30.5	-300	1.6	30.5	2.0	11	60°	10	15	617	734	1 150	1 680
40		59		41		1.85	38	2.0	12	50°			1 070	1 270	2 020	2 960
45	0 -19	64	-300	44.5	-300	1.85	43	2.0	15	50°	10	15	1 460	1 540	2 780	3 560
52		70		49.5		2.1	49	2.0	17	50°			1 610	1 710	3 080	3 940
60	0 -19	80	-300	60.5	-300	2.1	57	2.0	20	50°	12	20	2 710	2 870	4 890	6 250
80		100		74		2.6	76.5	2.0	25	50°			3 940	4 180	7 130	9 120

# IKO Linear Bushing with Seals : Metric series

Standard type : **LBD...UU**      Adjustable clearance type : **LBD...UU AJ**      Open type : **LBD...UU OP**

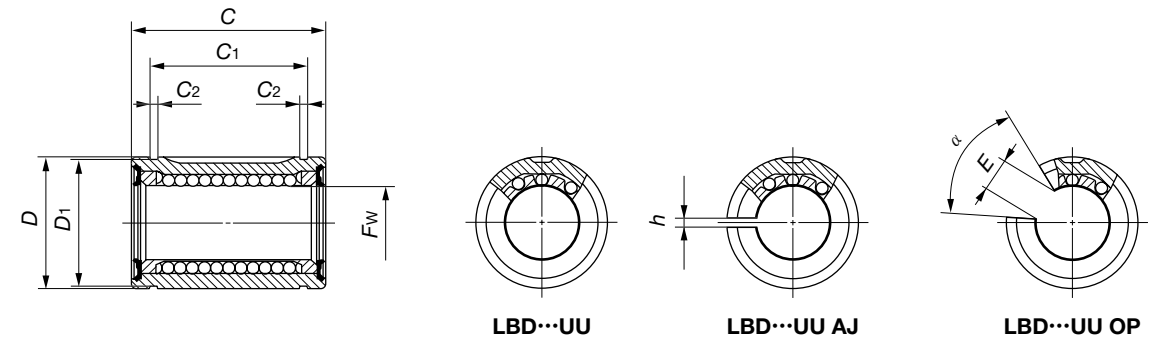

Shaft diameter mm	Standard type	Model number								Fw	Tolerance μm	
		Ball circuits	Mass (Ref.) g	Adjustable clearance type	Ball circuits	Mass (Ref.) g	Open type	Ball circuits	Mass (Ref.) g		Pre- cision	High
6	LBD 6 UU	3	5.2	LBD 6 UU AJ	3	5.1	—	—	—	6		
8	LBD 8S UU	3	8.4	LBD 8S UU AJ	3	8.2	—	—	—	8		
	LBD 8 UU	3	11.8	LBD 8 UU AJ	3	11.6	—	—	—	8		
10	LBD 10 UU	4	25.5	LBD 10 UU AJ	4	25.5	LBD 10 UU OP	3	20.5	10	0	0
13	LBD 13 UU	4	41.5	LBD 13 UU AJ	4	40.5	LBD 13 UU OP	3	33.5	13		
16	LBD 16 UU	4	58	LBD 16 UU AJ	4	57	LBD 16 UU OP	3	47.5	16		
20	LBD 20 UU	5	80.5	LBD 20 UU AJ	5	79.5	LBD 20 UU OP	4	69.5	20		
25	LBD 25 UU	5	161	LBD 25 UU AJ	5	159	LBD 25 UU OP	4	143	25	0	0
30	LBD 30 UU	6	220	LBD 30 UU AJ	6	220	LBD 30 UU OP	5	197	30		
35	LBD 35 UU	6	320	LBD 35 UU AJ	6	320	LBD 35 UU OP	5	280	35		
40	LBD 40 UU	6	440	LBD 40 UU AJ	6	435	LBD 40 UU OP	5	390	40	0	0
50	LBD 50 UU	6	1 400	LBD 50 UU AJ	6	1 380	LBD 50 UU OP	5	1 220	50	0	0

Note(1) : When circlips are used for mounting, the dimension C<sub>1</sub> minus twice the width of circlip becomes the width of hub.  
Remark : In the tolerance and eccentricity columns, "Precision" refers to precision class and "High" refers to high class.

Nominal dimensions and tolerances mm											Eccentricity		Basic dynamic load rating C		Basic static load rating C <sub>0</sub>	
D	Tolerance μm	C	Tolerance μm	C <sub>1</sub> ( <sup>1</sup> )	Tolerance μm	C <sub>2</sub>	D <sub>1</sub>	h	E	α Degree	Max. μm		Load direction A N	Load direction B N	Load direction A N	Load direction B N
12		19		13.5		1.1	11.5	1.5	—	—	8	12	78.0	63.4	155	155
15	<sup>0</sup> / <sub>-11</sub>	17		11.5		1.1	14.3	1.5	—	—			74.7	60.7	128	128
15		24		17.5		1.1	14.3	1.5	—	—			121	98.6	255	255
19		29	<sup>0</sup> / <sub>-200</sub>	22	<sup>0</sup> / <sub>-200</sub>	1.3	18	1.5	7	80°	10	15	197	226	405	573
23	<sup>0</sup> / <sub>-13</sub>	32		23		1.3	22	1.5	9	80°			292	336	578	818
28		37		26.5		1.6	27	1.5	11	80°			426	489	766	1 080
32		42		30.5		1.6	30.5	2.0	11	60°	12	20	617	734	1 150	1 680
40	<sup>0</sup> / <sub>-16</sub>	59		41		1.85	38	2.0	12	50°			1 070	1 270	2 020	2 960
45		64		44.5		1.85	43	2.0	15	50°			1 460	1 540	2 780	3 560
52		70	<sup>0</sup> / <sub>-300</sub>	49.5	<sup>0</sup> / <sub>-300</sub>	2.1	49	2.0	17	50°	12	20	1 610	1 710	3 080	3 940
60	<sup>0</sup> / <sub>-19</sub>	80		60.5		2.1	57	2.0	20	50°			2 710	2 870	4 890	6 250
80		100		74		2.6	76.5	2.0	25	50°			3 940	4 180	7 130	9 120

# IKO Linear Bushing : Inch series

Standard type : **LBB**      Adjustable clearance type : **LBB...AJ**      Open type : **LBB...OP**

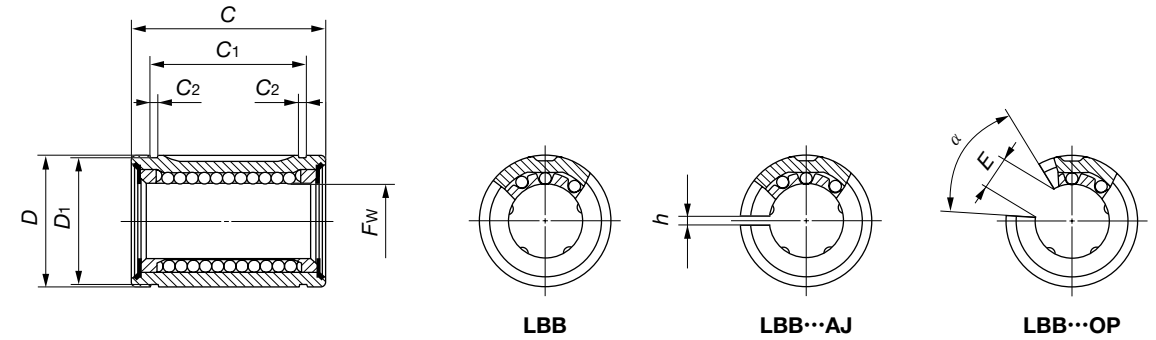

Shaft diameter mm (inch)	Standard type	Model number								Fw	Tolerance μm	
		Ball circuits	Mass (Ref.) g	Adjustable clearance type	Ball circuits	Mass (Ref.) g	Open type	Ball circuits	Mass (Ref.) g		Pre- cision	High
6.350 (1/4)	LBB 4	3	7.1	—	—	—	—	—	—	1/4 6.350		
9.525 (3/8)	LBB 6	4	10.3	—	—	—	—	—	—	3/8 9.525		
12.700 (1/2)	LBB 8	4	32	LBB 8 AJ	4	31.5	LBB 8 OP	3	28	1/2 12.700	0	0
15.875 (5/8)	LBB 10	4	65	LBB 10 AJ	4	64	LBB 10 OP	3	54	5/8 15.875	-8	-13
19.050 (3/4)	LBB 12	5	79.5	LBB 12 AJ	5	78.5	LBB 12 OP	4	68.5	3/4 19.050		
25.400 (1)	LBB 16	5	147	LBB 16 AJ	5	145	LBB 16 OP	4	127	1 25.400		
31.750 (1 1/4)	LBB 20	6	325	LBB 20 AJ	6	320	LBB 20 OP	5	285	1 1/4 31.750	0	0
38.100 (1 1/2)	LBB 24	6	535	LBB 24 AJ	6	530	LBB 24 OP	5	470	1 1/2 38.100	-10	-15
50.800 (2)	LBB 32	6	1 040	LBB 32 AJ	6	1 030	LBB 32 OP	5	915	2 50.800		0 -20

Note(1) : When circlips are used for mounting, the dimension C<sub>1</sub> minus twice the width of circlip becomes the width of hub.  
Remark : In the tolerance and eccentricity columns, "Precision" refers to precision class and "High" refers to high class.

Nominal dimensions and tolerances mm											Eccentricity Max. μm		Basic dynamic load rating C		Basic static load rating C <sub>0</sub>	
D	Tolerance μm	C	Tolerance μm	C <sub>1</sub> (1)	Tolerance μm	C <sub>2</sub>	D <sub>1</sub>	h	E	α Degree	Pre- cision	High	Load direction A N	Load direction B N	Load direction A N	Load direction B N
1/2 12.700		3/4 19.050		12.98		0.99	12.04	—	—	—		12	80.0	64.9	156	156
5/8 15.875		7/8 22.225		16.15		0.99	15.16	—	—	—		8	117	134	227	320
7/8 22.225	0	1 1/4 31.750	0	24.46	0	1.17	21.21	1/16 1.588	5/16 7.938	50°		13	290	333	577	816
1 1/8 28.575	-10	1 1/2 38.100	-381	28.04	-200	1.42	27.30	3/32 2.381	3/8 9.525	60°		9	424	488	766	1 080
1 1/4 31.750		1 5/8 41.275		29.61		1.42	30.33	3/32 2.381	7/16 11.112	60°		14	608	724	1 150	1 680
1 1/2 39.688		2 1/4 57.150		44.53		1.73	37.85	3/32 2.381	9/16 14.288	60°		10	1 070	1 280	2 020	2 960
2 50.800	0	2 5/8 66.675	0	50.92	0	1.73	48.51	3/32 2.381	5/8 15.875	50°		15	1 920	2 030	3 570	4 570
2 3/8 60.325	-13	3 76.200	-508	61.26	-300	2.18	57.53	1/8 3.175	3/4 19.050	50°		11	2 460	2 610	4 330	5 540
3 76.200	0 -15	4 101.600	0	81.07	0	2.62	72.64	1/8 3.175	1 25.400	50°		17	3 960	4 190	7 140	9 130



# IKO Linear Bushing with Seals : Inch series

Standard type : LBB...UU      Adjustable clearance type : LBB...UU AJ      Open type : LBB...UU OP

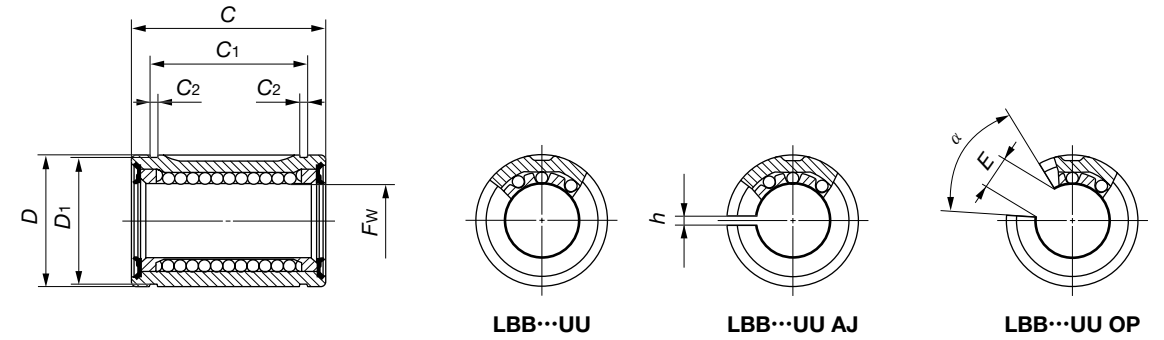

Shaft diameter mm (inch)	Standard type	Ball circuits	Model number						Fw	Tolerance $\mu\text{m}$			
			Mass (Ref.)	Adjustable clearance type	Ball circuits	Mass (Ref.)	Open type	Ball circuits		Mass (Ref.)	Pre-precision	High	
6.350 (1/4)	LBB 4 UU	3	7.1	—	—	—	—	—	1/4	6.350			
9.525 (3/8)	LBB 6 UU	4	10.4	—	—	—	—	—	3/8	9.525			
12.700 (1/2)	LBB 8 UU	4	32	LBB 8 UU AJ	4	31.5	LBB 8 UU OP	3	28	1/2	12.700	0	0
15.875 (5/8)	LBB 10 UU	4	65	LBB 10 UU AJ	4	64	LBB 10 UU OP	3	54	5/8	15.875	-8	-13
19.050 (3/4)	LBB 12 UU	5	80	LBB 12 UU AJ	5	79	LBB 12 UU OP	4	69	3/4	19.050		
25.400 (1)	LBB 16 UU	5	148	LBB 16 UU AJ	5	145	LBB 16 UU OP	4	128	1	25.400		
31.750 (1 1/4)	LBB 20 UU	6	325	LBB 20 UU AJ	6	320	LBB 20 UU OP	5	290	1 1/4	31.750	0	0
38.100 (1 1/2)	LBB 24 UU	6	535	LBB 24 UU AJ	6	530	LBB 24 UU OP	5	475	1 1/2	38.100	-10	-15
50.800 (2)	LBB 32 UU	6	1 040	LBB 32 UU AJ	6	1 030	LBB 32 UU OP	5	920	2	50.800		0

Note(1) : When circlips are used for mounting, the dimension C<sub>1</sub> minus twice the width of circlip becomes the width of hub.  
Remark : In the tolerance and eccentricity columns, "Precision" refers to precision class and "High" refers to high class.

Nominal dimensions and tolerances mm											Eccentricity Max. $\mu\text{m}$		Basic dynamic load rating C		Basic static load rating C <sub>0</sub>	
D	Tolerance $\mu\text{m}$	C	Tolerance $\mu\text{m}$	C <sub>1</sub> (1)	Tolerance $\mu\text{m}$	C <sub>2</sub>	D <sub>1</sub>	h	E	$\alpha$ Degree	Pre-precision	High	Load direction A N	Load direction B N	Load direction A N	Load direction B N
1/2 12.700		3/4 19.050		12.98		0.99	12.04	—	—	—		12	80.0	64.9	156	156
5/8 15.875		7/8 22.225		16.15		0.99	15.16	—	—	—		8	117	134	227	320
7/8 22.225	0	1 1/4 31.750	0	24.46	0	1.17	21.21	1/16 1.588	5/16 7.938	50°		13	290	333	577	816
1 1/8 28.575	-10	1 1/2 38.100	-381	28.04	-200	1.42	27.30	3/32 2.381	3/8 9.525	60°		9	424	488	766	1 080
1 1/4 31.750		1 5/8 41.275		29.61		1.42	30.33	3/32 2.381	7/16 11.112	60°		14	608	724	1 150	1 680
1 1/2 39.688		2 1/4 57.150		44.53		1.73	37.85	3/32 2.381	9/16 14.288	60°		10	1 070	1 280	2 020	2 960
2 50.800	0	2 5/8 66.675	0	50.92	0	1.73	48.51	3/32 2.381	5/8 15.875	50°		15	1 920	2 030	3 570	4 570
2 3/8 60.325	-13	3 76.200	-508	61.26	-300	2.18	57.53	1/8 3.175	3/4 19.050	50°		11	2 460	2 610	4 330	5 540
3 76.200	0	4 101.600	0	81.07	0	2.62	72.64	1/8 3.175	1 25.400	50°		17	3 960	4 190	7 140	9 130

# IKO Linear Bushing : Metric series



<b>Standard type :</b> LM LM...N (Synthetic resin retainer)	<b>Adjustable clearance type :</b> LM... AJ LM...N AJ (Synthetic resin retainer)	<b>Open type :</b> LM... OP LM...N OP (Synthetic resin retainer)
---	--	--

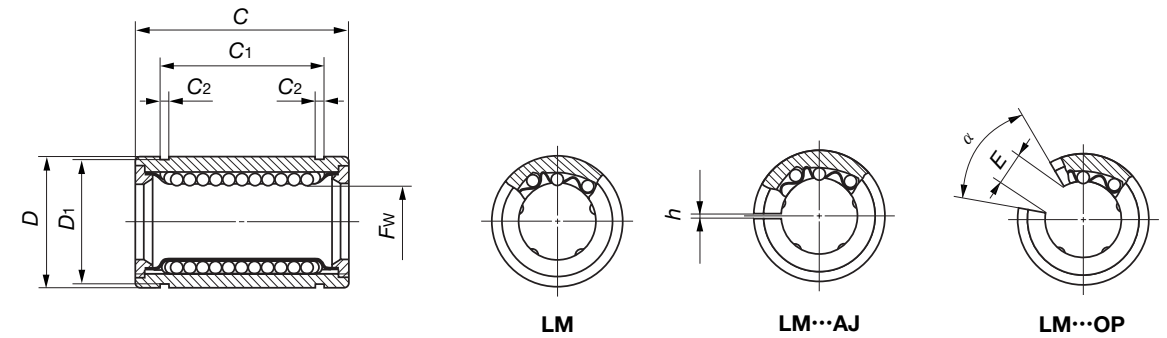

Shaft diameter mm	Model number									
	Standard type	Ball circuits	Mass (Ref.) g	Adjustable clearance type	Ball circuits	Mass (Ref.) g	Open type	Ball circuits	Mass (Ref.) g	
6	LM 61219	4	8.5	—	—	—	—	—	—	
	LM 61219N	4	7.6	LM 61219N AJ	4	7.5	—	—	—	
8	LM 81517	4	11	—	—	—	—	—	—	
	LM 81517N	4	10.4	LM 81517N AJ	4	10	—	—	—	
	LM 81524	4	17	—	—	—	—	—	—	
	LM 81524N	4	15	LM 81524N AJ	4	14.7	—	—	—	
10	LM 101929	4	36	—	—	—	—	—	—	
	LM 101929N	4	29.5	LM 101929N AJ	4	29	LM 101929N OP	3	23	
12	LM 122130	4	42	LM 122130 AJ	4	41	LM 122130 OP	3	32	
	LM 122130N	4	31.5	LM 122130N AJ	4	31	LM 122130N OP	3	25	
13	LM 132332	4	49	LM 132332 AJ	4	48	LM 132332 OP	3	37.5	
	LM 132332N	4	43	LM 132332N AJ	4	42	LM 132332N OP	3	34	
16	LM 162837	4	78	LM 162837 AJ	4	77	LM 162837 OP	3	60	
	LM 162837N	4	69.5	LM 162837N AJ	4	68	LM 162837N OP	3	52	
20	LM 203242	5	100	LM 203242 AJ	5	98	LM 203242 OP	4	85	
	LM 203242N	5	98	LM 203242N AJ	5	95	LM 203242N OP	4	69	
25	LM 254059	6	260	LM 254059 AJ	6	255	LM 254059 OP	5	220	
	LM 254059N	6	220	LM 254059N AJ	6	216	LM 254059N OP	5	188	
30	LM 304564	6	290	LM 304564 AJ	6	285	LM 304564 OP	5	245	
	LM 304564N	6	250	LM 304564N AJ	6	245	LM 304564N OP	5	210	
35	LM 355270	6	425	LM 355270 AJ	6	420	LM 355270 OP	5	355	
	LM 355270N	6	390	LM 355270N AJ	6	384	LM 355270N OP	5	335	
40	LM 406080	6	675	LM 406080 AJ	6	665	LM 406080 OP	5	575	
	LM 406080N	6	585	LM 406080N AJ	6	579	LM 406080N OP	5	500	
50	LM 5080100	6	1 740	LM 5080100 AJ	6	1 720	LM 5080100 OP	5	1 480	
	LM 5080100N	6	1 580	LM 5080100N AJ	6	1 560	LM 5080100N OP	5	1 340	

F <sub>w</sub>	Nominal dimensions and tolerances mm													Eccentricity		Basic dynamic load rating C		Basic static load rating C <sub>0</sub>			
	Tolerance μm		D	Tolerance μm	C	Tolerance μm	C <sub>1</sub> ( <sup>1</sup> )	Tolerance μm	C <sub>2</sub>	D <sub>1</sub>	h	E	α Degree	Max. μm	Precision	High	Load direction A N	Load direction B N	Load direction A N	Load direction B N	
	Pre-precision	High																			
6			12		19		13.5		1.1	11.5	—	—	—	—	—	80.7	92.7	167	237		
8			15	0 -11	17		11.5		1.1	14.3	—	—	—	—			87.4	100	160	226	
8			15		24		17.5		1.1	14.3	—	—	—	—	—	121	139	255	361		
10	0 -6	0 -9	19		29	0	22	0	1.3	18	—	—	—	—	8 12			179	206	354	501
12			21	0	30	-200	23	-200	1.3	20	1.5	8	80			259	298	503	711		
13			23	-13	32		23		1.3	22	1.5	9	80			266	306	506	716		
16			28		37		26.5		1.6	27	1.5	11	80			426	489	766	1 080		
20			32		42		30.5		1.6	30.5	1.5	11	60				562	668	1 010	1 470	
25	0 -7	0 -10	40	0 -16	59		41		1.85	38	2	12	50	10 15			920	974	1 780	2 280	
30			45		64		44.5		1.85	43	2.5	15	50			1 350	1 430	2 500	3 200		
35			52		70	0 -300	49.5	0 -300	2.1	49	2.5	17	50				1 610	1 710	3 080	3 940	
40	0 -8	0 -12	60	0 -19	80		60.5		2.1	57	3	20	50	12 20			2 030	2 150	3 620	4 640	
50			80		100		74		2.6	76.5	3	25	50			3 940	4 180	7 130	9 120		

Note(1) : When circlips are used for mounting, the dimension C<sub>1</sub> minus twice the width of circlip becomes the width of hub.  
 Remark 1 : In the tolerance and eccentricity columns, "Precision" refers to precision class and "High" refers to high class.  
 2 : The end plate for the standard type and the adjustable clearance type with a shaft diameter of 40 mm or less is fixed using a stop ring for hole.

# IKO Linear Bushing : Metric series

<b>Standard type :</b> <b>LM</b> <b>LM...N</b> (Synthetic resin retainer)	<b>Adjustable clearance type :</b> <b>LM... AJ</b> <b>LM...N AJ</b> (Synthetic resin retainer)	<b>Open type :</b> <b>LM... OP</b> <b>LM...N OP</b> (Synthetic resin retainer)
---	--	--

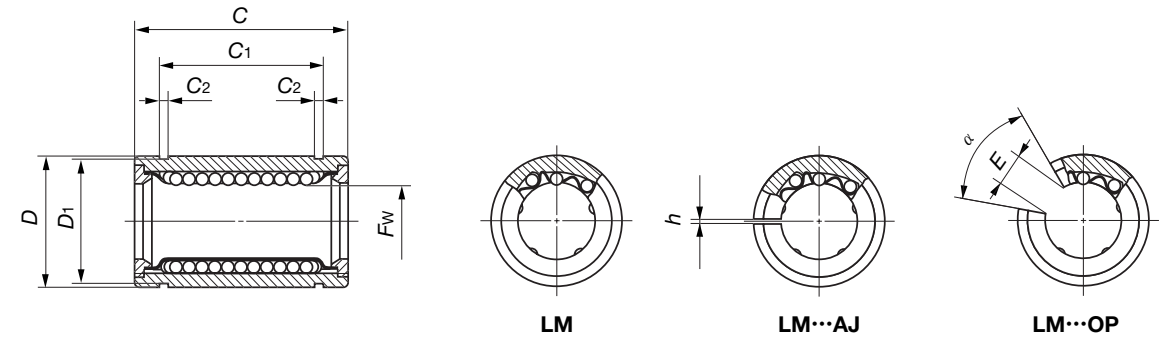

Shaft diameter mm	Model number													
	Standard type		Ball circuits	Mass (Ref.) g	Adjustable clearance type		Ball circuits	Mass (Ref.) g	Open type		Ball circuits	Mass (Ref.) g		
60	LM	6090110			6	2 000			LM	6090110			AJ	6
	LM	6090110N	6	1 860	LM	6090110N	AJ	6	1 820	LM	6090110N	OP	5	1 610
80	LM	80120140	6	4 480	LM	80120140	AJ	6	4 440	LM	80120140	OP	5	3 810
100	LM	100150175	6	9 620	LM	100150175	AJ	6	9 540	LM	100150175	OP	5	8 180
120	LM	120180200	8	15 000	LM	120180200	AJ	8	14 900	LM	120180200	OP	6	11 600
150	LM	150210240	8	20 300	LM	150210240	AJ	8	20 200	LM	150210240	OP	6	15 700

Note(1) : When circlips are used for mounting, the dimension C<sub>1</sub> minus twice the width of circlip becomes the width of hub.  
 Remark : In the tolerance and eccentricity columns, "Precision" refers to precision class and "High" refers to high class.

Nominal dimensions and tolerances mm														Eccentricity		Basic dynamic load rating C		Basic static load rating C <sub>0</sub>	
F <sub>w</sub>	Tolerance μm		D	Tolerance μm	C	Tolerance μm	C <sub>1</sub> (1)	Tolerance μm	C <sub>2</sub>	D <sub>1</sub>	h	E	α De- gree	Max. μm		Load direction A N	Load direction B N	Load direction A N	Load direction B N
	Pre- cision	High												Pre- cision	High				
60	0	0	90	0	110	0	85	-300	3.15	86.5	3	30	50	17	25	4 760	5 040	8 150	10 400
80	-9	-15	120	-22	140	0	105.5	-400	4.15	116	3	40	50			8 710	9 220	14 500	18 500
100	0	0	150	0	175	0	125.5	0	4.15	145	3	50	50	20	30	14 500	15 300	22 800	29 200
120	-10	-20	180	-25	200	-400	158.6	-400	4.15	175	4	85	80			25 800	25 500	44 300	49 400
150	0	0	210	0	240	-400	170.6	-400	5.15	204	4	105	80	25	40	35 600	35 100	61 200	68 200

# IKO Linear Bushing with Seals : Metric series

<b>Standard type :</b> LM... UU LM...N UU (Synthetic resin retainer)	<b>Adjustable clearance type :</b> LM... UU AJ LM...N UU AJ (Synthetic resin retainer)	<b>Open type :</b> LM... UU OP LM...N UU OP (Synthetic resin retainer)
--	--	--

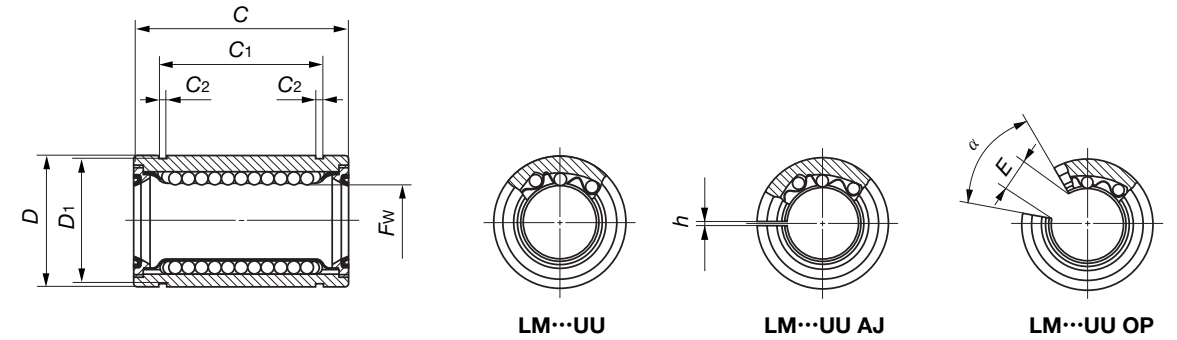

Shaft diameter mm	Model number								
	Standard type	Ball circuits	Mass (Ref.) g	Adjustable clearance type	Ball circuits	Mass (Ref.) g	Open type	Ball circuits	Mass (Ref.) g
6	LM 61219 UU	4	8.5	—	—	—	—	—	—
	LM 61219N UU	4	7.6	LM 61219N UU AJ	4	7.5	—	—	—
8	LM 81517 UU	4	11	—	—	—	—	—	—
	LM 81517N UU	4	10.4	LM 81517N UU AJ	4	10	—	—	—
	LM 81524 UU	4	17	—	—	—	—	—	—
	LM 81524N UU	4	15	LM 81524N UU AJ	4	14.7	—	—	—
10	LM 101929 UU	4	31	—	—	—	—	—	—
	LM 101929N UU	4	29.5	LM 101929N UU AJ	4	29	LM 101929N UU OP	3	23
12	LM 122130 UU	4	41	LM 122130 UU AJ	4	40	LM 122130 UU OP	3	31
	LM 122130N UU	4	31.5	LM 122130N UU AJ	4	31	LM 122130N UU OP	3	25
13	LM 132332 UU	4	49	LM 132332 UU AJ	4	48	LM 132332 UU OP	3	37.5
	LM 132332N UU	4	43	LM 132332N UU AJ	4	42	LM 132332N UU OP	3	34
16	LM 162837 UU	4	78	LM 162837 UU AJ	4	77	LM 162837 UU OP	3	60
	LM 162837N UU	4	69.5	LM 162837N UU AJ	4	68	LM 162837N UU OP	3	52
20	LM 203242 UU	5	100	LM 203242 UU AJ	5	98	LM 203242 UU OP	4	85
	LM 203242N UU	5	98	LM 203242N UU AJ	5	95	LM 203242N UU OP	4	69
25	LM 254059 UU	6	260	LM 254059 UU AJ	6	255	LM 254059 UU OP	5	220
	LM 254059N UU	6	220	LM 254059N UU AJ	6	216	LM 254059N UU OP	5	188
30	LM 304564 UU	6	290	LM 304564 UU AJ	6	285	LM 304564 UU OP	5	245
	LM 304564N UU	6	250	LM 304564N UU AJ	6	245	LM 304564N UU OP	5	210
35	LM 355270 UU	6	410	LM 355270 UU AJ	6	405	LM 355270 UU OP	5	346
	LM 355270N UU	6	390	LM 355270N UU AJ	6	384	LM 355270N UU OP	5	335
40	LM 406080 UU	6	675	LM 406080 UU AJ	6	665	LM 406080 UU OP	5	575
	LM 406080N UU	6	585	LM 406080N UU AJ	6	579	LM 406080N UU OP	5	500
50	LM 5080100 UU	6	1 740	LM 5080100 UU AJ	6	1 720	LM 5080100 UU OP	5	1 480
	LM 5080100N UU	6	1 580	LM 5080100N UU AJ	6	1 560	LM 5080100N UU OP	5	1 340

Nominal dimensions and tolerances mm														Eccentricity Max. $\mu\text{m}$ Precision/High	Basic dynamic load rating C		Basic static load rating C <sub>0</sub>	
$F_w$	Tolerance $\mu\text{m}$ Precision/High	D	Tolerance $\mu\text{m}$	C	Tolerance $\mu\text{m}$	C <sub>1</sub> ( <sup>1</sup> )	Tolerance $\mu\text{m}$	C <sub>2</sub>	D <sub>1</sub>	h	E	$\alpha$ Degree	Load direction A N		Load direction B N	Load direction A N	Load direction B N	
6		12		19		13.5		1.1	11.5	1	—	—	8	12	80.7	92.7	167	237
8		15	0 -11	17		11.5		1.1	14.3	1	—	—			87.4	100	160	226
8		15		24		17.5		1.1	14.3	1	—	—			121	139	255	361
10	0 -6	0 -9		29	0 -200	22	0 -200	1.3	18	1	—	—			179	206	354	501
12			0	30		23		1.3	20	1.5	8	80			259	298	503	711
13			-13	32		23		1.3	22	1.5	9	80			266	306	506	716
16				37		26.5		1.6	27	1.5	11	80			426	489	766	1 080
20				42		30.5		1.6	30.5	1.5	11	60			562	668	1 010	1 470
25	0 -7	0 -10	0 -16	59		41		1.85	38	2	12	50	10	15	920	974	1 780	2 280
30				64		44.5		1.85	43	2.5	15	50			1 350	1 430	2 500	3 200
35			0 -300	70	0 -300	49.5	0 -300	2.1	49	2.5	17	50			1 610	1 710	3 080	3 940
40	0 -8	0 -12	0 -19	80		60.5		2.1	57	3	20	50	12	20	2 030	2 150	3 620	4 640
50				100		74		2.6	76.5	3	25	50			3 940	4 180	7 130	9 120

Note(1) : When circlips are used for mounting, the dimension C<sub>1</sub> minus twice the width of circlip becomes the width of hub.  
 Remark 1 : In the tolerance and eccentricity columns, "Precision" refers to precision class and "High" refers to high class.  
 2 : The end plate for the standard type and the adjustable clearance type with a shaft diameter of 40mm or less is fixed using a stop ring for hole.

# IKO Linear Bushing with Seals : Metric series

<b>Standard type :</b> LM... UU LM...N UU (Synthetic resin retainer)	<b>Adjustable clearance type :</b> LM... UU AJ LM...N UU AJ (Synthetic resin retainer)	<b>Open type :</b> LM... UU OP LM...N UU OP (Synthetic resin retainer)
--	--	--

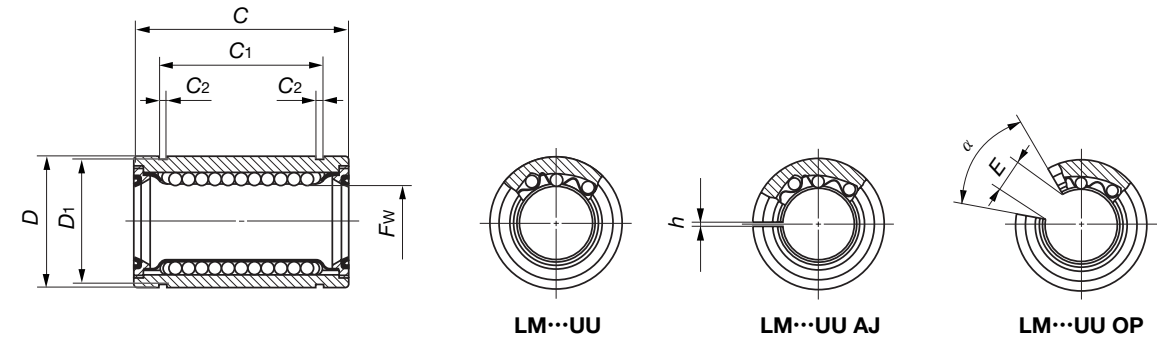

Shaft diameter mm	Model number								
	Standard type	Ball circuits	Mass (Ref.) g	Adjustable clearance type	Ball circuits	Mass (Ref.) g	Open type	Ball circuits	Mass (Ref.) g
60	LM 6090110 UU	6	2 000	LM 6090110 UU AJ	6	1 980	LM 6090110 UU OP	5	1 700
	LM 6090110N UU	6	1 860	LM 6090110N UU AJ	6	1 820	LM 6090110N UU OP	5	1 610
80	LM 80120140 UU	6	4 480	LM 80120140 UU AJ	6	4 440	LM 80120140 UU OP	5	3 810
100	LM 100150175 UU	6	9 620	LM 100150175 UU AJ	6	9 540	LM 100150175 UU OP	5	8 180
120	LM 120180200 UU	8	14 700	LM 120180200 UU AJ	8	14 600	LM 120180200 UU OP	6	11 400
150	LM 150210240 UU	8	19 900	LM 150210240 UU AJ	8	19 800	LM 150210240 UU OP	6	15 400

Note(\*): When circlips are used for mounting, the dimension C<sub>1</sub> minus twice the width of circlip becomes the width of hub.  
Remark : In the tolerance and eccentricity columns, "Precision" refers to precision class and "High" refers to high class.

Nominal dimensions and tolerances mm														Eccentricity		Basic dynamic load rating C		Basic static load rating C <sub>0</sub>	
F <sub>w</sub>	Tolerance μm		D	Tolerance μm	C	Tolerance μm	C <sub>1</sub> (*)	Tolerance μm	C <sub>2</sub>	D <sub>1</sub>	h	E	α Degree	Max. μm		Load direction A	Load direction B	Load direction A	Load direction B
	Pre-precision	High												Pre-precision	High	N	N	N	N
60	0	0	90	0	110	-300	85	-300	3.15	86.5	3	30	50	17	25	4 760	5 040	8 150	10 400
	-9	-15														-22	140	105.5	4.15
100	0	0	150	0	175	0	125.5	0	4.15	145	3	50	50	20	30	14 500	15 300	22 800	29 200
120	-10	-20	180	-25	200	-400	158.6	-400	4.15	175	4	85	80			25 800	25 500	44 300	49 400
150	0	0	210	0	240		170.6		5.15	204	4	105	80	25	40	35 600	35 100	61 200	68 200
	-13	-25		-29															

# IKO Linear Bushing : Metric series

<b>Standard type :</b> LME LME...N (Synthetic resin retainer)	<b>Adjustable clearance type :</b> LME... AJ LME...N AJ (Synthetic resin retainer)	<b>Open type :</b> LME... OP LME...N OP (Synthetic resin retainer)
---	--	--

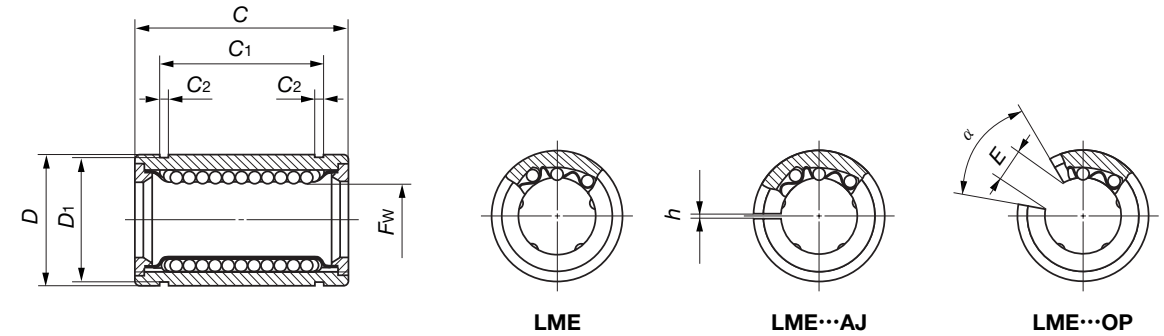

Shaft diameter mm	Model number											
	Standard type		Ball circuits	Mass (Ref.) g	Adjustable clearance type		Ball circuits	Mass (Ref.) g	Open type		Ball circuits	Mass (Ref.) g
5	LME	51222N	4	10	LME	51222N AJ	4	9.5	—		—	—
8	LME	81625	4	22.5	—		—	—	—		—	—
	LME	81625N	4	20	LME	81625N AJ	4	19	—		—	—
12	LME	122232	4	45.5	LME	122232 AJ	4	44.5	LME	122232 OP	3	35
	LME	122232N	4	41	LME	122232N AJ	4	40	LME	122232N OP	3	32
16	LME	162636	4	59	LME	162636 AJ	4	58	LME	162636 OP	3	45
	LME	162636N	4	56.5	LME	162636N AJ	4	54.5	LME	162636N OP	3	44
20	LME	203245	5	105	LME	203245 AJ	5	100	LME	203245 OP	4	84
	LME	203245N	5	92	LME	203245N AJ	5	90	LME	203245N OP	4	75
25	LME	254058	6	240	LME	254058 AJ	6	235	LME	254058 OP	5	200
	LME	254058N	6	220	LME	254058N AJ	6	215	LME	254058N OP	5	181
30	LME	304768	6	360	LME	304768 AJ	6	355	LME	304768 OP	5	300
	LME	304768N	6	325	LME	304768N AJ	6	320	LME	304768N OP	5	272
40	LME	406280	6	800	LME	406280 AJ	6	790	LME	406280 OP	5	670
	LME	406280N	6	705	LME	406280N AJ	6	694	LME	406280N OP	5	600
50	LME	5075100	6	1 260	LME	5075100 AJ	6	1 250	LME	5075100 OP	5	1 060
	LME	5075100N	6	1 130	LME	5075100N AJ	6	1 110	LME	5075100N OP	5	970
60	LME	6090125	6	2 270	LME	6090125 AJ	6	2 240	LME	6090125 OP	5	1 900
	LME	6090125N	6	1 860	LME	6090125N AJ	6	1 820	LME	6090125N OP	5	1 610
80	LME	80120165	6	5 140	LME	80120165 AJ	6	5 100	LME	80120165 OP	5	4 350

Note(1) : When circlips are used for mounting, the dimension C<sub>1</sub> minus twice the width of circlip becomes the width of hub.

Nominal dimensions and tolerances mm														Eccentricity Max. μm	Basic dynamic load rating C		Basic static load rating C <sub>0</sub>	
F <sub>w</sub>	Tolerance μm	D	Tolerance μm	C	Tolerance μm	C <sub>1</sub> (1)	Tolerance μm	C <sub>2</sub>	D <sub>1</sub>	h	E	α Degree	Load direction A N		Load direction B N	Load direction A N	Load direction B N	
5	+8 0	12	0	22	0 -200	14.5	0 -200	1.1	11.5	1	—	—	12	90.8	104	219	310	
8		16	-8	25		16.5		1.1	15.2	1	—	—		121	139	255	361	
12		22	0	32		22.9		1.3	21	1.5	7.5	78		259	298	503	711	
16	+9 -1	26	-9	36	0 -200	24.9	0 -200	1.3	24.9	1.5	10	78	15	283	325	514	726	
20		32	0	45		31.5		1.6	30.3	2	10	60		562	668	1 010	1 470	
25	+11 -1	40	0	58	0 -300	44.1	0 -300	1.85	37.5	2	12.5	60	17	920	974	1 780	2 280	
30		47	-11	68		52.1		1.85	44.5	2	12.5	50		1 350	1 430	2 500	3 200	
40	+13 -2	62	0	80	0 -400	60.6	0 -400	2.15	59	3	16.8	50	20	2 030	2 150	3 620	4 640	
50		75	-13	100		77.6		2.65	72	3	21	50		3 940	4 180	7 130	9 120	
60		90	0	125		101.7		3.15	86.5	3	27.2	54		4 760	5 040	8 150	10 400	
80	+16 -4	120	-15	165	133.7	4.15	116	3	36.3	54	8 710	9 220	14 500	18 500				

# IKO Linear Bushing with Seals : Metric series

<b>Standard type :</b> LME... UU LME...N UU (Synthetic resin retainer)	<b>Adjustable clearance type :</b> LME... UU AJ LME...N UU AJ (Synthetic resin retainer)	<b>Open type :</b> LME... UU OP LME...N UU OP (Synthetic resin retainer)
--	--	--

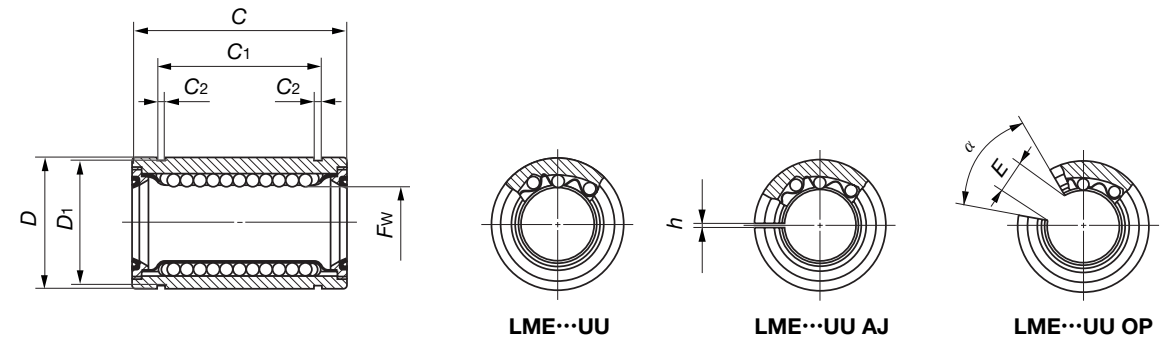

Shaft diameter mm	Standard type		Ball circuits	Mass (Ref.) g	Adjustable clearance type		Ball circuits	Mass (Ref.) g	Open type		Ball circuits	Mass (Ref.) g
	Model number	Model number			Model number	Model number						
5	LME 51222N UU	4	10	LME 51222N UU AJ	4	9.5						
8	LME 81625 UU	4	22									
	LME 81625N UU	4	20	LME 81625N UU AJ	4	19						
12	LME 122232 UU	4	45.5	LME 122232 UU AJ	4	44.5	LME 122232 UU OP	3	35			
	LME 122232N UU	4	41	LME 122232N UU AJ	4	40	LME 122232N UU OP	3	32			
16	LME 162636 UU	4	59	LME 162636 UU AJ	4	58	LME 162636 UU OP	3	45			
	LME 162636N UU	4	56.5	LME 162636N UU AJ	4	54.5	LME 162636N UU OP	3	44			
20	LME 203245 UU	5	105	LME 203245 UU AJ	5	100	LME 203245 UU OP	4	84			
	LME 203245N UU	5	92	LME 203245N UU AJ	5	90	LME 203245N UU OP	4	75			
25	LME 254058 UU	6	240	LME 254058 UU AJ	6	235	LME 254058 UU OP	5	200			
	*LME 254058N UU	6	220	*LME 254058N UU AJ	6	215	*LME 254058N UU OP	5	181			
30	LME 304768 UU	6	360	LME 304768 UU AJ	6	355	LME 304768 UU OP	5	300			
	LME 304768N UU	6	325	LME 304768N UU AJ	6	320	LME 304768N UU OP	5	272			
40	LME 406280 UU	6	800	LME 406280 UU AJ	6	790	LME 406280 UU OP	5	670			
	LME 406280N UU	6	705	LME 406280N UU AJ	6	694	LME 406280N UU OP	5	600			
50	LME 5075100 UU	6	1 260	LME 5075100 UU AJ	6	1 250	LME 5075100 UU OP	5	1 060			
	LME 5075100N UU	6	1 130	LME 5075100N UU AJ	6	1 110	LME 5075100N UU OP	5	970			
60	LME 6090125 UU	6	2 270	LME 6090125 UU AJ	6	2 240	LME 6090125 UU OP	5	1 900			
	LME 6090125N UU	6	2 050	LME 6090125N UU AJ	6	2 000	LME 6090125N UU OP	5	1 580			
80	LME 80120165 UU	6	5 140	LME 80120165 UU AJ	6	5 100	LME 80120165 UU OP	5	4 350			

Note(\*): When circlips are used for mounting, the dimension C<sub>1</sub> minus twice the width of circlip becomes the width of hub.  
 Remark : Seals of the Linear Bushings marked with an asterisk (\*) protrude a little from the end face of external cylinder.

F <sub>w</sub>	Nominal dimensions and tolerances mm												Eccentricity Max. μm	Basic dynamic load rating C		Basic static load rating C <sub>0</sub>	
	Tolerance μm	D	Tolerance μm	C	Tolerance μm	C <sub>1</sub> (*)	Tolerance μm	C <sub>2</sub>	D <sub>1</sub>	h	E	α Degree		Load direction A N	Load direction B N	Load direction A N	Load direction B N
5		12	0	22		14.5		1.1	11.5	1	-	-	12	90.8	104	219	310
8	+8 0	16	-8	25		16.5		1.1	15.2	1	-	-		121	139	255	361
12		22	0	32	0 -200	22.9	0 -200	1.3	21	1.5	7.5	78	259	298	503	711	
16	+9 -1	26	-9	36		24.9		1.3	24.9	1.5	10	78	283	325	514	726	
20		32	0	45		31.5		1.6	30.3	2	10	60	562	668	1 010	1 470	
25	+11 -1	40	-11	58		44.1		1.85	37.5	2	12.5	60	920	974	1 780	2 280	
30		47	0	68	0 -300	52.1	0 -300	1.85	44.5	2	12.5	50	1 350	1 430	2 500	3 200	
40		62	0	80		60.6		2.15	59	3	16.8	50	2 030	2 150	3 620	4 640	
50	+13 -2	75	-13	100		77.6		2.65	72	3	21	50	3 940	4 180	7 130	9 120	
60		90	0	125	0 -400	101.7	0 -400	3.15	86.5	3	27.2	54	4 760	5 040	8 150	10 400	
80	+16 -4	120	-15	165		133.7		4.15	116	3	36.3	54	8 710	9 220	14 500	18 500	

# IKO Linear Bushing : Inch series

<b>Standard type :</b> <b>LMB</b> <b>LMB...N</b> (Synthetic resin retainer)	<b>Adjustable clearance type :</b> <b>LMB... AJ</b> <b>LMB...N AJ</b> (Synthetic resin retainer)	<b>Open type :</b> <b>LMB... OP</b> <b>LMB...N OP</b> (Synthetic resin retainer)
---	--	--

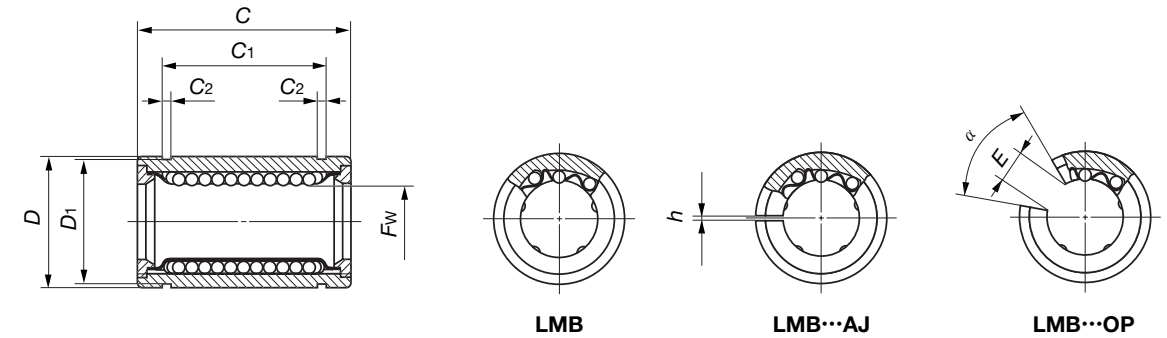

Shaft diameter mm (inch)	Model number											
	Standard type		Ball circuits	Mass (Ref.) g	Adjustable clearance type		Ball circuits	Mass (Ref.) g	Open type		Ball circuits	Mass (Ref.) g
6.350 ( <sup>1</sup> / <sub>4</sub> )	LMB	4812	3	9.1	—		—	—	—		—	—
	LMB	4812N	4	8.5	LMB	4812N AJ	4	8.0	—		—	—
9.525 ( <sup>3</sup> / <sub>8</sub> )	LMB	61014	4	27.5	—		—	—	—		—	—
	LMB	61014N	4	12.5	LMB	61014N AJ	4	12	—		—	—
12.700 ( <sup>1</sup> / <sub>2</sub> )	LMB	81420	4	44	LMB	81420 AJ	4	43	LMB	81420 OP	3	33.5
	LMB	81420N	4	40	LMB	81420N AJ	4	38	LMB	81420N OP	3	28
15.875 ( <sup>5</sup> / <sub>8</sub> )	LMB	101824	4	85	LMB	101824 AJ	4	83	LMB	101824 OP	3	64
	LMB	101824N	4	76	LMB	101824N AJ	4	74	LMB	101824N OP	3	57
19.050 ( <sup>3</sup> / <sub>4</sub> )	LMB	122026	5	98	LMB	122026 AJ	5	96	LMB	122026 OP	4	81
	LMB	122026N	5	95	LMB	122026N AJ	5	93	LMB	122026N OP	4	76
25.400 (1)	LMB	162536	6	220	LMB	162536 AJ	6	218	LMB	162536 OP	5	190
	LMB	162536N	6	200	LMB	162536N AJ	6	198	LMB	162536N OP	5	170
31.750 ( <sup>1</sup> <sup>1</sup> / <sub>4</sub> )	LMB	203242	6	490	LMB	203242 AJ	6	485	LMB	203242 OP	5	415
	LMB	203242N	6	440	LMB	203242N AJ	6	430	LMB	203242N OP	5	370
38.100 ( <sup>1</sup> <sup>1</sup> / <sub>2</sub> )	LMB	243848	6	730	LMB	243848 AJ	6	720	LMB	243848 OP	5	620
	LMB	243848N	6	670	LMB	243848N AJ	6	660	LMB	243848N OP	5	570
50.800 (2)	LMB	324864	6	1 530	LMB	324864 AJ	6	1 510	LMB	324864 OP	5	1 300
	LMB	324864N	6	1 140	LMB	324864N AJ	6	1 120	LMB	324864N OP	5	980
63.500 ( <sup>2</sup> <sup>1</sup> / <sub>2</sub> )	LMB	406080	6	2 400	LMB	406080 AJ	6	2 380	LMB	406080 OP	5	2 040
	LMB	487296	6	4 400	LMB	487296 AJ	6	4 360	LMB	487296 OP	5	3 740
76.200 (3)	LMB	487296	6	4 400	LMB	487296 AJ	6	4 360	LMB	487296 OP	5	3 740
	LMB	6496128	6	11 000	LMB	6496128 AJ	6	10 900	LMB	6496128 OP	5	9 350

Note(1) : When circlips are used for mounting, the dimension C<sub>1</sub> minus twice the width of circlip becomes the width of hub.  
 (2) : The load rating for three rows of ball circuits is shown as a representative value.  
 Remark : In the tolerance and eccentricity columns, "Precision" refers to precision class and "High" refers to high class.

Nominal dimensions and tolerances mm															Eccentricity Max. μm	Basic dynamic load rating C		Basic static load rating C <sub>0</sub>	
F <sub>w</sub>	Tolerance μm	D	Tolerance μm	C	Tolerance μm	C <sub>1</sub> ( <sup>1</sup> )	Tolerance μm	C <sub>2</sub>	D <sub>1</sub>	h	E	α De- gree	Load direction A N	Load direction B N		Load direction A N	Load direction B N		
<sup>1</sup> / <sub>4</sub>	0	<sup>1</sup> / <sub>2</sub>	0	<sup>3</sup> / <sub>4</sub>	0	12.98	0	0.992	11.906	—	—	—	( <sup>2</sup> )	( <sup>2</sup> )	( <sup>2</sup> )	( <sup>2</sup> )			
6.350	0	12.700	-11	19.050	0	12.98	0	0.992	11.906	1	—	—	82.6	67.0	168	168			
<sup>3</sup> / <sub>8</sub>	0	<sup>5</sup> / <sub>8</sub>	0	<sup>7</sup> / <sub>8</sub>	0	16.15	0	0.992	14.935	—	—	—	94.8	109	174	246			
9.525	0	15.875	0	22.225	0	16.15	0	0.992	14.935	1	—	—	94.8	109	174	246			
<sup>1</sup> / <sub>2</sub>	-6	<sup>7</sup> / <sub>8</sub>	0	<sup>1</sup> / <sub>4</sub>	0	24.46	0	1.168	20.853	1.5	8.7	80	264	303	505	714			
12.700	-6	22.225	-13	31.750	-200	24.46	-200	1.168	20.853	1.5	8.7	80	264	303	505	714			
<sup>5</sup> / <sub>8</sub>	0	<sup>1</sup> / <sub>8</sub>	0	<sup>1</sup> / <sub>2</sub>	0	28.04	0	1.422	26.899	1.5	9.5	80	424	488	766	1 080			
15.875	0	28.575	0	38.100	0	28.04	0	1.422	26.899	1.5	9.5	80	424	488	766	1 080			
<sup>3</sup> / <sub>4</sub>	0	<sup>1</sup> / <sub>4</sub>	0	<sup>5</sup> / <sub>8</sub>	0	29.61	0	1.422	29.870	1.5	10.7	60	554	659	1 000	1 470			
19.050	0	31.750	0	41.275	0	29.61	0	1.422	29.870	1.5	10.7	60	554	659	1 000	1 470			
1	-7	<sup>9</sup> / <sub>16</sub>	-16	<sup>2</sup> / <sub>4</sub>	0	44.53	0	1.727	37.306	1.5	11.8	50	923	978	1 780	2 280			
25.400	-7	39.688	-16	57.150	0	44.53	0	1.727	37.306	1.5	11.8	50	923	978	1 780	2 280			
<sup>1</sup> / <sub>4</sub>	0	2	0	<sup>2</sup> / <sub>8</sub>	0	50.92	0	1.727	47.904	2.5	14.7	50	1 370	1 450	2 510	3 210			
31.750	0	50.800	0	66.675	0	50.92	0	1.727	47.904	2.5	14.7	50	1 370	1 450	2 510	3 210			
<sup>1</sup> / <sub>2</sub>	0	<sup>2</sup> / <sub>8</sub>	-19	3	0	61.26	0	2.184	56.870	3	17.7	50	2 010	2 130	3 610	4 620			
38.100	-8	60.325	-19	76.200	-300	61.26	-300	2.184	56.870	3	17.7	50	2 010	2 130	3 610	4 620			
2	0	3	0	4	0	81.07	0	2.616	72.085	3	24.7	50	3 960	4 190	7 140	9 130			
50.800	0	76.200	0	101.600	0	81.07	0	2.616	72.085	3	24.7	50	3 960	4 190	7 140	9 130			
<sup>2</sup> / <sub>2</sub>	0	<sup>3</sup> / <sub>4</sub>	0	5	0	100.99	0	3.048	90.220	3	29.5	50	5 190	5 490	9 090	11 600			
63.500	0	95.250	-22	127.000	0	100.99	0	3.048	90.220	3	29.5	50	5 190	5 490	9 090	11 600			
3	-9	<sup>4</sup> / <sub>2</sub>	0	6	0	120.04	0	3.048	109.474	3	39.6	50	8 620	9 120	14 500	18 500			
76.200	-9	114.300	0	152.400	0	120.04	0	3.048	109.474	3	39.6	50	8 620	9 120	14 500	18 500			
4	0	6	0	8	-400	158.95	-400	3.53	145.923	3	49.5	50	17 000	18 000	28 600	36 500			
101.600	-10	152.400	-25	203.200	-400	158.95	-400	3.53	145.923	3	49.5	50	17 000	18 000	28 600	36 500			



# IKO Stainless Steel Linear Bushing : Metric series



**Standard type :** LM... F  
**Adjustable clearance type :** LM... FAJ  
**Open type :** LM... F OP  
 LM...N F (Synthetic resin retainer) LM...N FAJ (Synthetic resin retainer) LM...N F OP (Synthetic resin retainer)

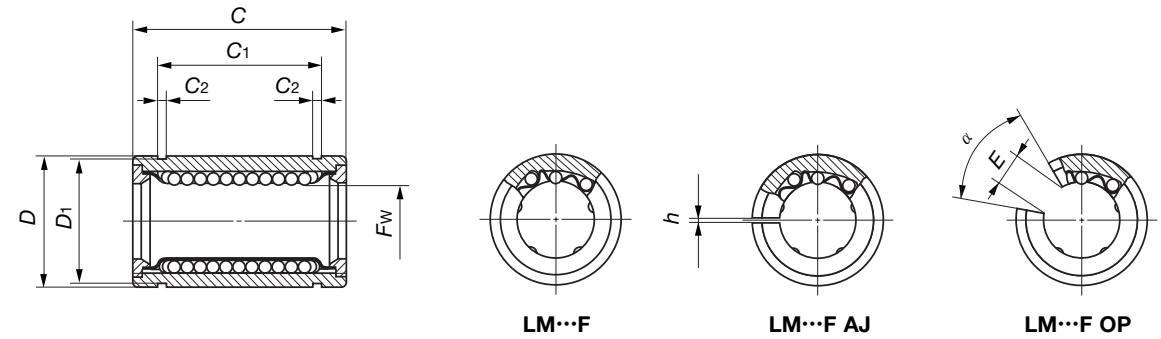

Shaft diameter mm	Model number								
	Standard type	Ball circuits	Mass (Ref.) g	Adjustable clearance type	Ball circuits	Mass (Ref.) g	Open type	Ball circuits	Mass (Ref.) g
6	LM 61219 F	4	8.5	—	—	—	—	—	—
	LM 61219N F	4	7.6	LM 61219N F AJ	4	7.5	—	—	—
8	LM 81517 F	4	11	—	—	—	—	—	—
	LM 81517N F	4	10.4	LM 81517N F AJ	4	10	—	—	—
	LM 81524 F	4	17	—	—	—	—	—	—
	LM 81524N F	4	15	LM 81524N F AJ	4	14.7	—	—	—
10	LM 101929 F	4	36	—	—	—	—	—	—
	LM 101929N F	4	29.5	LM 101929N F AJ	4	29	LM 101929N F OP	3	23
12	LM 122130 F	4	42	LM 122130 F AJ	4	41	LM 122130 F OP	3	32
	LM 122130N F	4	31.5	LM 122130N F AJ	4	31	LM 122130N F OP	3	25
13	LM 132332 F	4	49	LM 132332 F AJ	4	48	LM 132332 F OP	3	37.5
	LM 132332N F	4	43	LM 132332N F AJ	4	42	LM 132332N F OP	3	34
16	LM 162837 F	4	78	LM 162837 F AJ	4	77	LM 162837 F OP	3	60
	LM 162837N F	4	69.5	LM 162837N F AJ	4	68	LM 162837N F OP	3	52
20	LM 203242 F	5	100	LM 203242 F AJ	5	98	LM 203242 F OP	4	85
	LM 203242N F	5	98	LM 203242N F AJ	5	95	LM 203242N F OP	4	69
25	LM 254059 F	6	260	LM 254059 F AJ	6	255	LM 254059 F OP	5	220
	LM 254059N F	6	220	LM 254059N F AJ	6	216	LM 254059N F OP	5	188
30	LM 304564 F	6	290	LM 304564 F AJ	6	285	LM 304564 F OP	5	245
	LM 304564N F	6	250	LM 304564N F AJ	6	245	LM 304564N F OP	5	210
35	LM 355270 F	6	410	LM 355270 F AJ	6	405	LM 355270 F OP	5	346
	LM 355270N F	6	390	LM 355270N F AJ	6	384	LM 355270N F OP	5	335
40	LM 406080 F	6	654	LM 406080 F AJ	6	640	LM 406080 F OP	5	546
	LM 406080N F	6	585	LM 406080N F AJ	6	579	LM 406080N F OP	5	500
50	LM 5080100 F	6	1 700	LM 5080100 F AJ	6	1 680	LM 5080100 F OP	5	1 420
	LM 5080100N F	6	1 580	LM 5080100N F AJ	6	1 560	LM 5080100N F OP	5	1 340
60	LM 6090110 F	6	2 000	LM 6090110 F AJ	6	1 980	LM 6090110 F OP	5	1 650
	LM 6090110N F	6	1 860	LM 6090110N F AJ	6	1 820	LM 6090110N F OP	5	1 610

Note(1) : When circlips are used for mounting, the dimension C<sub>1</sub> minus twice the width of circlip becomes the width of hub.

F <sub>w</sub>	Nominal dimensions and tolerances mm											Eccentricity		Basic dynamic load rating C		Basic static load rating C <sub>0</sub>				
	Tolerance μm		D	Tolerance μm	C	Tolerance μm	C <sub>1</sub> (1)	Tolerance μm	C <sub>2</sub>	D <sub>1</sub>	h	E	α De- gree	Max. μm	Pre- cision	High	Load direction A N	Load direction B N	Load direction A N	Load direction B N
	Pre- cision	High																		
6			12		19		13.5		1.1	11.5	—	—				80.7	92.7	167	237	
8			15	0 -11	17		11.5		1.1	14.3	—	—				87.4	100	160	226	
			15		24		17.5		1.1	14.3	—	—				121	139	255	361	
10	0 -6	0 -9	19		29	0	22	0	1.3	18	—	—	8	80	8	12	179	206	354	501
			21		30	-200	23	-200	1.3	20	1.5	8	80				259	298	503	711
13			23	0 -13	32		23		1.3	22	1.5	9	80			266	306	506	716	
			28		37		26.5		1.6	27	1.5	11	80				426	489	766	1 080
20			32		42		30.5		1.6	30.5	1.5	11	60			562	668	1 010	1 470	
			40	0 -7	59		41		1.85	38	2	12	50	10	15	920	974	1 780	2 280	
30			45		64		44.5		1.85	43	2.5	15	50			1 350	1 430	2 500	3 200	
			52		70	0	49.5	0	2.1	49	2.5	17	50			1 610	1 710	3 080	3 940	
40	0 -8	0 -12	60	0 -19	80	-300	60.5	-300	2.1	57	3	20	50	12	20	2 030	2 150	3 620	4 640	
			80		100		74		2.6	76.5	3	25	50			3 940	4 180	7 130	9 120	
60	0 -9	0 -15	90	0 -22	110		85		3.15	86.5	3	30	50	17	25	4 760	5 040	8 150	10 400	

Remark 1 : In the tolerance and eccentricity columns, "Precision" refers to precision class and "High" refers to high class.

2 : The end plate for the standard type and the adjustable clearance type with a shaft diameter of 40 mm or less is fixed using a stop ring for hole.

# IKO Stainless Steel Linear Bushing with Seals : Metric series



**Standard type :**  
**LM... F UU**  
**LM...N F UU** (Synthetic resin retainer)

**Adjustable clearance type :**  
**LM... F UU AJ**  
**LM...N F UU AJ** (Synthetic resin retainer)

**Open type :**  
**LM... F UU OP**  
**LM...N F UU OP** (Synthetic resin retainer)

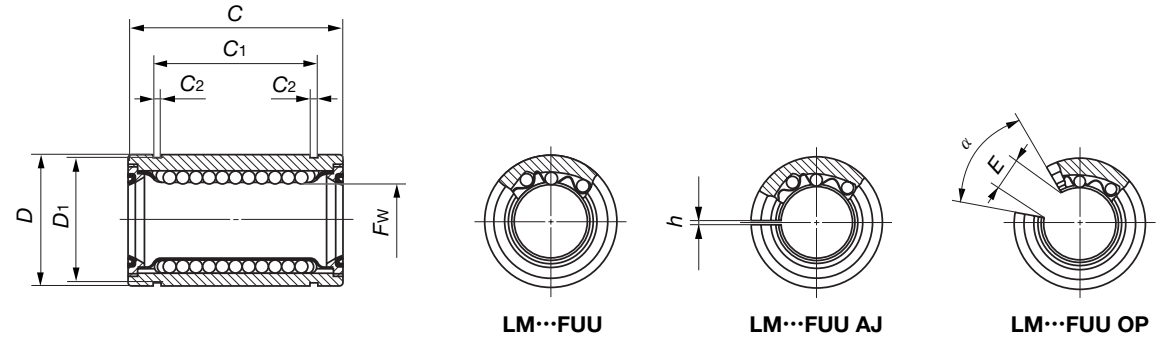

Shaft diameter mm	Model number								
	Standard type	Ball circuits	Mass (Ref.) g	Adjustable clearance type	Ball circuits	Mass (Ref.) g	Open type	Ball circuits	Mass (Ref.) g
6	LM 61219 F UU	4	8.5	—	—	—	—	—	—
	LM 61219N F UU	4	7.6	LM 61219N F UU AJ	4	7.5	—	—	—
8	LM 81517 F UU	4	11	—	—	—	—	—	—
	LM 81517N F UU	4	10.4	LM 81517N F UU AJ	4	10	—	—	—
	LM 81524 F UU	4	17	—	—	—	—	—	—
	LM 81524N F UU	4	15	LM 81524N F UU AJ	4	14.7	—	—	—
10	LM 101929 F UU	4	31	—	—	—	—	—	—
	LM 101929N F UU	4	29.5	LM 101929N F UU AJ	4	29	LM 101929N F UU OP	3	23
12	LM 122130 F UU	4	41	LM 122130 F UU AJ	4	40	LM 122130 F UU OP	3	32
	LM 122130N F UU	4	31.5	LM 122130N F UU AJ	4	31	LM 122130N F UU OP	3	25
13	LM 132332 F UU	4	49	LM 132332 F UU AJ	4	48	LM 132332 F UU OP	3	37.5
	LM 132332N F UU	4	43	LM 132332N F UU AJ	4	42	LM 132332N F UU OP	3	34
16	LM 162837 F UU	4	78	LM 162837 F UU AJ	4	77	LM 162837 F UU OP	3	60
	LM 162837N F UU	4	69.5	LM 162837N F UU AJ	4	68	LM 162837N F UU OP	3	52
20	LM 203242 F UU	5	100	LM 203242 F UU AJ	5	98	LM 203242 F UU OP	4	85
	LM 203242N F UU	5	98	LM 203242N F UU AJ	5	95	LM 203242N F UU OP	4	69
25	LM 254059 F UU	6	260	LM 254059 F UU AJ	6	255	LM 254059 F UU OP	5	220
	LM 254059N F UU	6	220	LM 254059N F UU AJ	6	216	LM 254059N F UU OP	5	188
30	LM 304564 F UU	6	290	LM 304564 F UU AJ	6	285	LM 304564 F UU OP	5	245
	LM 304564N F UU	6	250	LM 304564N F UU AJ	6	245	LM 304564N F UU OP	5	210
35	LM 355270 F UU	6	410	LM 355270 F UU AJ	6	405	LM 355270 F UU OP	5	346
	LM 355270N F UU	6	390	LM 355270N F UU AJ	6	384	LM 355270N F UU OP	5	335
40	LM 406080 F UU	6	636	LM 406080 F UU AJ	6	622	LM 406080 F UU OP	5	546
	LM 406080N F UU	6	585	LM 406080N F UU AJ	6	579	LM 406080N F UU OP	5	500
50	LM 5080100 F UU	6	1 670	LM 5080100 F UU AJ	6	1 650	LM 5080100 F UU OP	5	1 410
	LM 5080100N F UU	6	1 580	LM 5080100N F UU AJ	6	1 560	LM 5080100N F UU OP	5	1 340
60	LM 6090110 F UU	6	1 930	LM 6090110 F UU AJ	6	1 910	LM 6090110 F UU OP	5	1 580
	LM 6090110N F UU	6	1 860	LM 6090110N F UU AJ	6	1 820	LM 6090110N F UU OP	5	1 610

Note(1) : When circlips are used for mounting, the dimension C<sub>1</sub> minus twice the width of circlip becomes the width of hub.

Nominal dimensions and tolerances mm														Eccentricity		Basic dynamic load rating		Basic static load rating			
F <sub>w</sub>	Tolerance μm		D	Tolerance μm	C	Tolerance μm	C <sub>1</sub> (1)	Tolerance μm	C <sub>2</sub>	D <sub>1</sub>	h	E	α Degree	Max. μm	Precision	High	Load direction A N	Load direction B N	Load direction A N	Load direction B N	
	Precision	High																			
6			12		19		13.5		1.1	11.5	1	-	-				80.7	92.7	167	237	
8			15	0	17		11.5		1.1	14.3	1	-	-				87.4	100	160	226	
				-11																	
8			15		24		17.5		1.1	14.3	1	-	-				121	139	255	361	
10	0	0	19		29	0	22	0	1.3	18	1	-	-	8	80	8	12	179	206	354	501
12			21		30	-200	23	-200	1.3	20	1.5	8	80				259	298	503	711	
13			23	0	32		23		1.3	22	1.5	9	80				266	306	506	716	
				-13																	
16			28		37		26.5		1.6	27	1.5	11	80				426	489	766	1 080	
20			32		42		30.5		1.6	30.5	1.5	11	60				562	668	1 010	1 470	
25	0	0	40	0	59		41		1.85	38	2	12	50	10	15		920	974	1 780	2 280	
				-7	-10																
30			45		64		44.5		1.85	43	2.5	15	50				1 350	1 430	2 500	3 200	
35			52		70	0	49.5	0	2.1	49	2.5	17	50				1 610	1 710	3 080	3 940	
40	0	0	60	0	80	-300	60.5	-300	2.1	57	3	20	50	12	20		2 030	2 150	3 620	4 640	
				-8	-12																
50			80		100		74		2.6	76.5	3	25	50				3 940	4 180	7 130	9 120	
60	0	0	90	0	110		85		3.15	86.5	3	30	50	17	25		4 760	5 040	8 150	10 400	
				-9	-15																

Remark 1 : In the tolerance and eccentricity columns, "Precision" refers to precision class and "High" refers to high class.  
 2 : The end plate for the standard type and the adjustable clearance type with a shaft diameter of 40 mm or less is fixed using a stop ring for hole.

# IKO Stainless Steel Linear Bushing : Metric series



<b>Standard type :</b> LME... F LME...N F (Synthetic resin retainer)	<b>Adjustable clearance type :</b> LME... F AJ LME...N F AJ (Synthetic resin retainer)	<b>Open type :</b> LME... F OP LME...N F OP (Synthetic resin retainer)
--	--	--

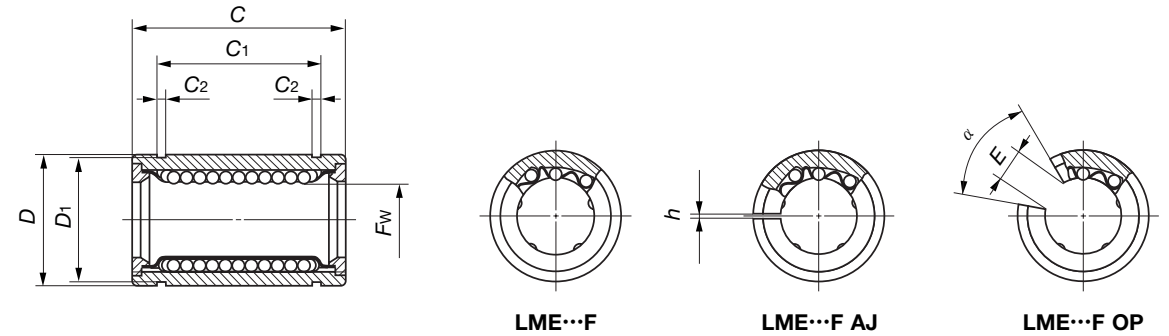

Shaft diameter mm	Model number											
	Standard type		Ball circuits	Mass (Ref.) g	Adjustable clearance type		Ball circuits	Mass (Ref.) g	Open type		Ball circuits	Mass (Ref.) g
5	LME 51222N F	4	10	LME 51222N F AJ	4	9.5	—		—		—	—
8	LME 81625 F	4	22	—		—	—		—		—	—
	LME 81625N F	4	20	LME 81625N F AJ	4	19	—		—		—	—
12	LME 122232 F	4	45.5	LME 122232 F AJ	4	44.5	LME 122232 F OP	3	35	3	35	
	LME 122232N F	4	41	LME 122232N F AJ	4	40	LME 122232N F OP	3	32			
16	LME 162636 F	4	59	LME 162636 F AJ	4	58	LME 162636 F OP	3	45	3	45	
	LME 162636N F	4	56.5	LME 162636N F AJ	4	54.5	LME 162636N F OP	3	44			
20	LME 203245 F	5	105	LME 203245 F AJ	5	100	LME 203245 F OP	4	84	4	84	
	LME 203245N F	5	92	LME 203245N F AJ	5	90	LME 203245N F OP	4	75			
25	LME 254058 F	6	240	LME 254058 F AJ	6	235	LME 254058 F OP	5	200	5	200	
	LME 254058N F	6	220	LME 254058N F AJ	6	215	LME 254058N F OP	5	181			
30	LME 304768 F	6	360	LME 304768 F AJ	6	355	LME 304768 F OP	5	300	5	300	
	LME 304768N F	6	325	LME 304768N F AJ	6	320	LME 304768N F OP	5	272			
40	LME 406280 F	6	770	LME 406280 F AJ	6	758	LME 406280 F OP	5	665	5	665	
	LME 406280N F	6	705	LME 406280N F AJ	6	694	LME 406280N F OP	5	600			
50	LME 5075100 F	6	1 250	LME 5075100 F AJ	6	1 230	LME 5075100 F OP	5	1 080	5	1 080	
	LME 5075100N F	6	1 130	LME 5075100N F AJ	6	1 110	LME 5075100N F OP	5	970			
60	LME 6090125 F	6	2 220	LME 6090125 F AJ	6	2 170	LME 6090125 F OP	5	1 900	5	1 900	
	LME 6090125N F	6	2 050	LME 6090125N F AJ	6	2 000	LME 6090125N F OP	5	1 580			

Note(1) : When circlips are used for mounting, the dimension C<sub>1</sub> minus twice the width of circlip becomes the width of hub.

Nominal dimensions and tolerances mm													Eccentricity Max. $\mu\text{m}$	Basic dynamic load rating C		Basic static load rating C <sub>0</sub>	
F <sub>w</sub>	Tolerance $\mu\text{m}$	D	Tolerance $\mu\text{m}$	C	Tolerance $\mu\text{m}$	C <sub>1</sub> ( <sup>1</sup> )	Tolerance $\mu\text{m}$	C <sub>2</sub>	D <sub>1</sub>	h	E	$\alpha$ Degree		Load direction A N	Load direction B N	Load direction A N	Load direction B N
5	+8 0	12	0	22	0 -200	14.5	0 -200	1.1	11.5	1	-	-	12	90.8	104	219	310
8		16	-8	25		16.5		1.1	15.2	1	-	-		121	139	255	361
12		22	0	32		22.9		1.3	21	1.5	7.5	78		259	298	503	711
16	+9 -1	26	-9	36	0 -200	24.9	0 -200	1.3	24.9	1.5	10	78	15	283	325	514	726
20		32	0	45		31.5		1.6	30.3	2	10	60		562	668	1 010	1 470
25	+11 -1	40	0	58	0 -300	44.1	0 -300	1.85	37.5	2	12.5	60	17	920	974	1 780	2 280
30		47	-11	68		52.1		1.85	44.5	2	12.5	50		1 350	1 430	2 500	3 200
40	+13 -2	62	0	80	0 -400	60.6	0 -400	2.15	59	3	16.8	50	20	2 030	2 150	3 620	4 640
50		75	-13	100		77.6		2.65	72	3	21	50		3 940	4 180	7 130	9 120
60	+13 -2	90	0	125	0 -400	101.7	0 -400	3.15	86.5	3	27.2	54	20	4 760	5 040	8 150	10 400

# IKO Stainless Steel Linear Bushing with Seals : Metric series

<b>Standard type :</b> LME... F UU LME...N F UU (Synthetic resin retainer)	<b>Adjustable clearance type :</b> LME... F UU AJ LME...N F UU AJ (Synthetic resin retainer)	<b>Open type :</b> LME... F UU OP LME...N F UU OP (Synthetic resin retainer)
--	--	--

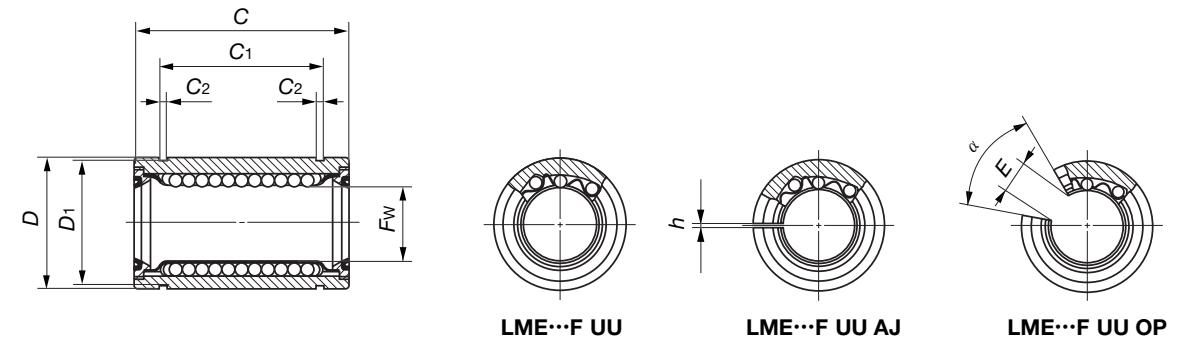

Shaft diameter mm	Model number									
	Standard type	Ball circuits	Mass (Ref.) g	Adjustable clearance type	Ball circuits	Mass (Ref.) g	Open type	Ball circuits	Mass (Ref.) g	
5	LME 51222N F UU	4	10	LME 51222N F UU AJ	4	9.5	—	—	—	
8	LME 81625 F UU	4	22	—	—	—	—	—	—	
	LME 81625N F UU	4	20	LME 81625N F UU AJ	4	19	—	—	—	
12	LME 122232 F UU	4	45.5	LME 122232 F UU AJ	4	44.5	LME 122232 F UU OP	3	35	
	LME 122232N F UU	4	41	LME 122232N F UU AJ	4	40	LME 122232N F UU OP	3	32	
16	LME 162636 F UU	4	59	LME 162636 F UU AJ	4	58	LME 162636 F UU OP	3	45	
	LME 162636N F UU	4	56.5	LME 162636N F UU AJ	4	54.5	LME 162636N F UU OP	3	44	
20	LME 203245 F UU	5	105	LME 203245 F UU AJ	5	100	LME 203245 F UU OP	4	84	
	LME 203245N F UU	5	92	LME 203245N F UU AJ	5	90	LME 203245N F UU OP	4	75	
25	LME 254058 F UU	6	240	LME 254058 F UU AJ	6	235	LME 254058 F UU OP	5	200	
	*LME 254058N F UU	6	220	*LME 254058N F UU AJ	6	215	*LME 254058N F UU OP	5	181	
30	LME 304768 F UU	6	360	LME 304768 F UU AJ	6	355	LME 304768 F UU OP	5	300	
	LME 304768N F UU	6	325	LME 304768N F UU AJ	6	320	LME 304768N F UU OP	5	272	
40	LME 406280 F UU	6	752	LME 406280 F UU AJ	6	740	LME 406280 F UU OP	5	645	
	LME 406280N F UU	6	705	LME 406280N F UU AJ	6	694	LME 406280N F UU OP	5	600	
50	LME 5075100 F UU	6	1 210	LME 5075100 F UU AJ	6	1 190	LME 5075100 F UU OP	5	1 050	
	LME 5075100N F UU	6	1 130	LME 5075100N F UU AJ	6	1 110	LME 5075100N F UU OP	5	970	
60	LME 6090125 F UU	6	2 160	LME 6090125 F UU AJ	6	2 110	LME 6090125 F UU OP	5	1 850	
	LME 6090125N F UU	6	2 050	LME 6090125N F UU AJ	6	2 000	LME 6090125N F UU OP	5	1 580	

Note(1) : When circlips are used for mounting, the dimension C<sub>1</sub> minus twice the width of circlip becomes the width of hub.  
 Remark : Seals of the Linear Bushings marked with an asterisk (\*) protrude a little from the end face of external cylinder.

Nominal dimensions and tolerances mm													Eccentricity Max. μm	Basic dynamic load rating C		Basic static load rating C <sub>0</sub>	
F <sub>w</sub>	Tolerance μm	D	Tolerance μm	C	Tolerance μm	C <sub>1</sub> ( <sup>1</sup> )	Tolerance μm	C <sub>2</sub>	D <sub>1</sub>	h	E	α Degree		Load direction A N	Load direction B N	Load direction A N	Load direction B N
5	+8 0	12	0	22	0 -200	14.5	0 -200	1.1	11.5	1	-	-	12	90.8	104	219	310
8		16	-8	25		16.5		1.1	15.2	1	-	-		121	139	255	361
12		22	0	32		22.9		1.3	21	1.5	7.5	78		259	298	503	711
16	+9 -1	26	-9	36	0 -200	24.9	0 -200	1.3	24.9	1.5	10	78	15	283	325	514	726
20		32	0	45		31.5		1.6	30.3	2	10	60		562	668	1 010	1 470
25	+11 -1	40	-11	58	0 -300	44.1	0 -300	1.85	37.5	2	12.5	60	17	920	974	1 780	2 280
30		47	0	68		52.1		1.85	44.5	2	12.5	50		1 350	1 430	2 500	3 200
40	+13 -2	62	0	80	0 -400	60.6	0 -400	2.15	59	3	16.8	50	20	2 030	2 150	3 620	4 640
50		75	-13	100		77.6		2.65	72	3	21	50		3 940	4 180	7 130	9 120
60		90	0 -15	125	0 -400	101.7	0 -400	3.15	86.5	3	27.2	54		4 760	5 040	8 150	10 400

# IKO Compact Linear Bushing

## LK

**IKO Compact Linear Bushing** is a linear motion rolling guide, incorporating steel balls and a retainer compactly in an external cylinder which is made from a thin special-steel plate by precision drawing, carburizing and quenching.

**IKO Compact Linear Bushing** can be used to greatly reduce the size and weight of linear motion part of machines, because its sectional height is as small as 4 to 5mm and it is mounted directly on the shaft which is used as the raceway. Steel balls are guided accurately by the retainer, so frictional resistance is small and a highly accurate linear motion can be obtained.

**IKO Compact Linear Bushing** is tightly fitted in the housing bore with an interference, so it is not necessary to fix it axially and handling is easy.

### ● Identification Number

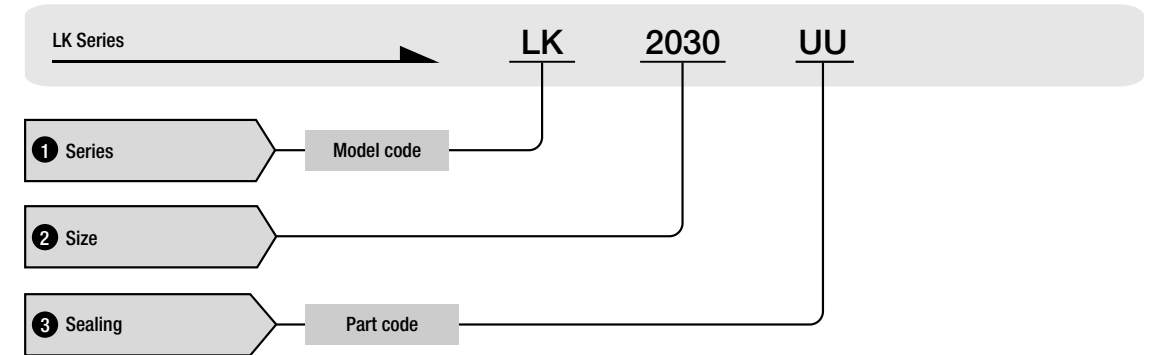

### Raceway surface

Since the shaft surface is used as a raceway for Compact Linear Bushing, the shaft must be heat-treated and ground. Recommended surface hardness and roughness of the shaft are shown in Table 1.

Table 1 Surface hardness and roughness of shaft

Item	Recommended value
Surface hardness	HRC58~64
Surface roughness <sup>(1)</sup>	0.2 $\mu$ mRa or less (0.8 $\mu$ mRy or less)

Note<sup>(1)</sup> : In case high accuracy is not required , 0.8 $\mu$ mRa(3.2 $\mu$ mRy) can be used.

Standard type : LK

Standard type : LK...UU

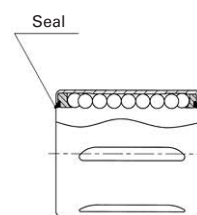
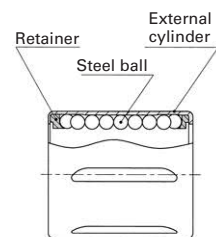

Structure of Compact Linear Bushing

# IKO Compact Linear Bushing

## Fit

The correct dimensions and accuracy **IKO** Compact Linear Bushing are obtained only after it has been press-fitted into the housing bore. As the external cylinder is thin, accuracy is directly affected by the dimensions, shape and rigidity of housing, so these factors must be examined carefully. The recommended fit is shown in Table 2.

**Table 2 Recommended fit**

Housing material	Tolerance class of shaft		Tolerance class of housing bore	
	Normal clearance	Closer clearance	Normal clearance	Closer clearance
Steel, Cast iron	h 6	j 5	H 7	H 6
Light alloy	h 6	j 5	K 7	K 6

## Mounting

**IKO** Compact Linear Bushing should be press-fitted into the housing gently, using an appropriate tool as shown in Fig.1 with its marked end and face up. As the external cylinder is thin, it must never be stuck directly with a hammer. Since the external cylinder of **IKO** Compact Linear Bushing is firmly press-fitted into the housing bore, it is not necessary to fix it axially.

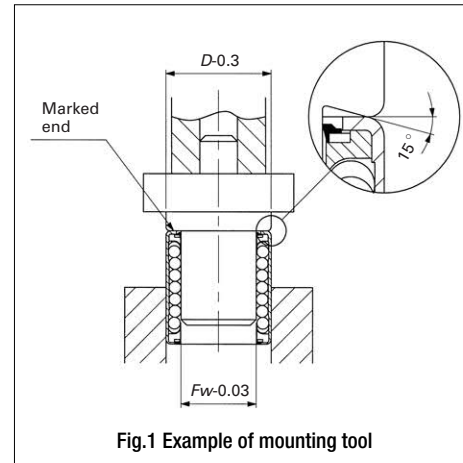

Standard type : LK  
With seals : LK...UU

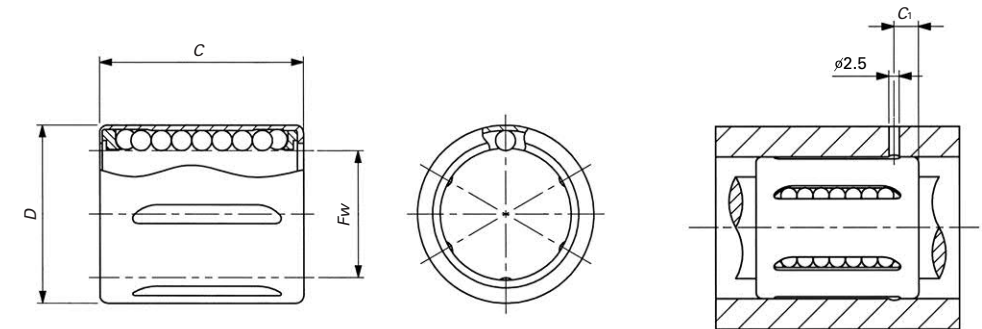

Oil hole in the housing

Shaft dia- mm	Identification Number mm						Boundary dimensions mm				Basic dynamic load rating <sup>(?)</sup>		Basic static load rating <sup>(?)</sup>	
	Standard type	Number of ball circuits	Weight (Reference) g	Sealed type	Number of ball circuits	Weight (Reference) g	Fw	D	C <sup>(1)</sup>	C <sub>1</sub>	Load direction A N	Load direction B N	Load direction A N	Load direction B N
16	LK 1630	5	24.4	LK 1630 UU	5	25.2	16	24	30	6	855	1 020	690	1 010
20	LK 2030	6	29.5	LK 2030 UU	6	30.4	20	28	30	6	1 060	1 120	874	1 120
25	LK 2540	6	61.4	LK 2540 UU	6	62.8	25	35	40	8	1 940	2 050	1 640	2 100
30	LK 3050	7	88.2	LK 3050 UU	7	89.8	30	40	50	8	2 790	2 750	2 670	3 070

Note<sup>(1)</sup> : The seal end of sealed type slightly protrudes from the end face of external cylinder.  
<sup>(?)</sup> : The load directions A and B are shown in the sketches below.

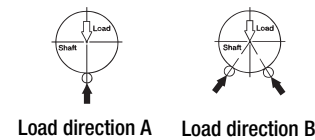

# Miniature Linear Bushing

LMS

**IKO** Miniature Linear Bushing is a miniature type linear motion rolling guide which travels along a shaft to achieve endless linear motion. The shaft diameter is 3~5 mm. In the external cylinder of Miniature Linear Bushing, a retainer, steel balls and stop rings are compactly incorporated, and precise positioning accuracy can be obtained.

## Low frictional linear motion

Steel balls are accurately guided by a retainer, so low frictional resistance and stable linear motion can be achieved.

## Compact design

Miniature Linear Bushing is very small in size, allowing for compact assembly in machines and equipment.

## Wide variations

In addition to the standard type, the high-rigidity long type is available. These types can be selected to suit the requirements in applications.

## Stainless steel type

Miniature Linear Bushings made of stainless steel are also available. This type is suitable for applications where corrosion resistance is important.

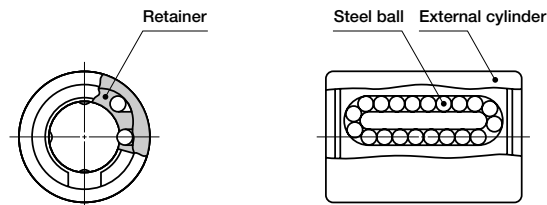

Structure of Miniature Linear Bushing

## Miniature Linear Bushing series

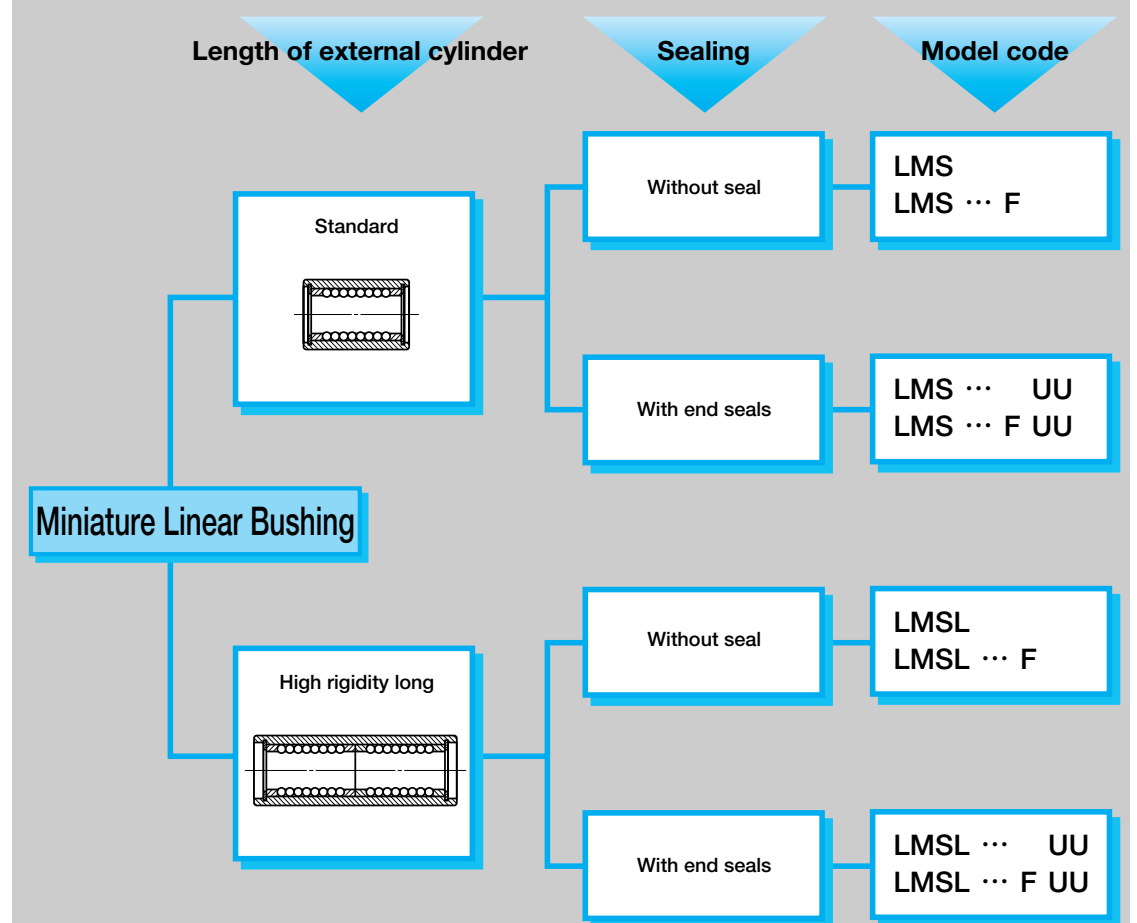

Remark : "F" in the model codes indicates a stainless steel type.

## ● Identification number and specification

The specification of Miniature Linear Bushing is indicated by the identification number, consisting of a model code, a size, a material symbol, a part code and a classification symbol.

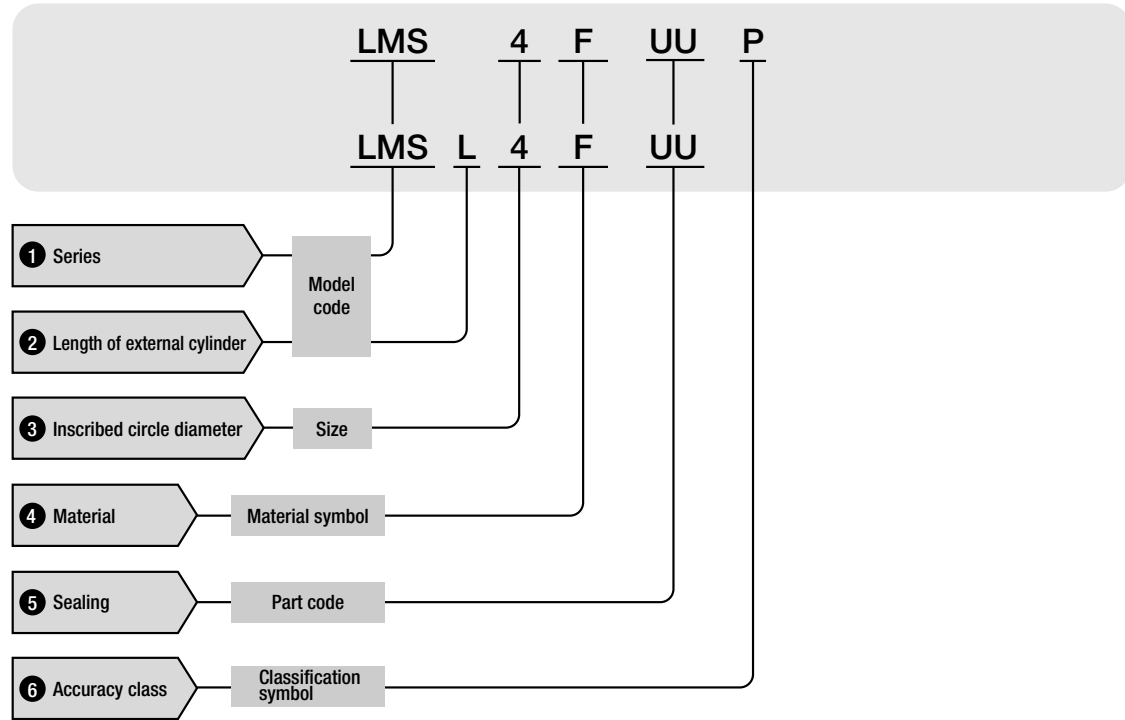

<b>1 Series</b>	LMS	
<b>2 Length of external cylinder</b>	Standard : No symbol High rigidity long : L	
<b>3 Inscribed circle diameter</b>		Indicate the inscribed circle diameter in mm.
<b>4 Material</b>	High carbon steel made : No symbol Stainless steel made : F	Specify the component part material.
<b>5 Sealing</b>	Without seal : No symbol With two end seals : UU	Sealed type incorporates seals with superior dust protection performance in both ends of the external cylinder for preventing intrusion of foreign matter.
<b>6 Accuracy class</b>	High : No symbol Precision : P	For details of accuracy, see the table of dimensions on page E-185. The precision class is applicable to standard type only. When strict control of radial internal clearance is required, specially controlled products of which inscribed circle diameter is selected within the divisions of every 0.002 mm can be delivered. If required, consult <b>IKO</b> .



## Load Rating

Summarized descriptions of load ratings of Miniature Linear Bushing are given below. For details of load rating definitions and load calculations, see "General description".

### Basic dynamic load rating $C$

The basic dynamic load rating is defined as the constant load both in direction and magnitude under which a group of identical Miniature Linear Bushings are individually operated and 90% of the units in the group can travel  $50 \times 10^3$  meters free from material damage due to rolling contact fatigue.

### Basic static load rating $C_0$

The basic static load rating is defined as the static load that gives a prescribed constant contact stress at the center of the contact area between the rolling element and raceway receiving the maximum load.

### Relationships between load ratings and the position of ball circuits

Load ratings of Miniature Linear Bushing are affected by the position of the ball circuits. In the table of dimensions, two types of load ratings are shown corresponding to the load directions and steel ball circuit positions as shown in Fig. 1 and Fig. 2.

In Fig. 1 the load direction is in line with the steel ball circuit position and this direction is referred to as load direction A in the table of dimensions. In general, the load ratings for this direction are also used, when the load direction is indeterminate or the steel ball circuit position in relation to the load direction cannot be determined.

In Fig. 2, the load direction is pointed at the center of two ball circuits and this direction is referred to as load direction B in the table of dimensions. In general, a larger load can be received in this case compared with load direction A.

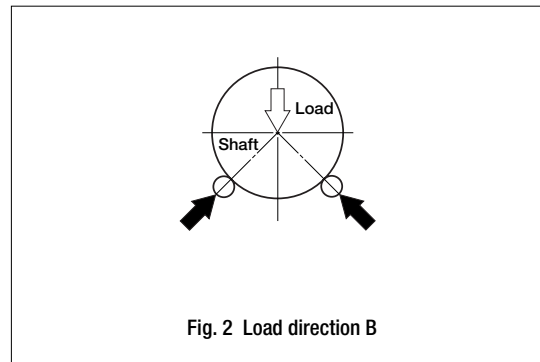
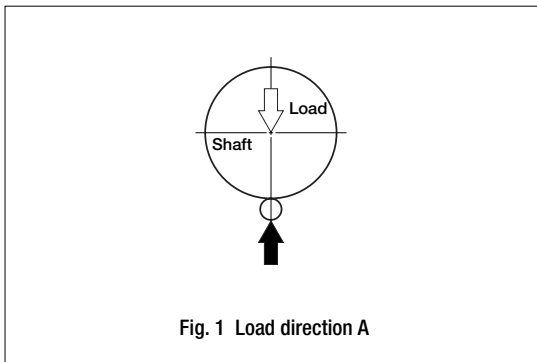

## Precautions for Use

### 1 Raceway surface

Since Miniature Linear Bushings operate with a shaft as a raceway surface, the shaft should be heat-treated and ground. Recommended surface hardness, roughness and minimum effective hardening depth of the shaft are shown in Table 1.

Table 1 Surface hardness, roughness and minimum effective hardening depth

Item	Recommended value	Remark
Surface hardness	58~64HRC	When the raceway hardness is less than the necessary hardness, multiply load ratings by the hardness factor.
Surface roughness	0.2 $\mu$ mRa or better (0.8 $\mu$ mRy or better)	—
Effective hardening depth	0.8mm or more	—

### 2 Lubrication

Miniature Linear Bushing can be used with oil or grease lubrication. It is a common practice to apply grease lightly on the shaft surface and steel balls for grease lubrication. A good quality lithium-soap base grease is recommended for grease lubrication.

### 3 When rotational motion is present

Miniature Linear Bushing can only be operated in linear motion and can not be rotated. When linear motion in short stroke length and rotation are both required, **IKO** Miniature Stroke Rotary Bushing (See page E-186.) is recommended.

### 4 Insertion of shaft

When Miniature Linear Bushing is assembled with the shaft, do not insert the shaft with angle. It is possible that the steel balls will fall out or the retainer will be deformed and smooth operation can not be obtained.

Precautions for Mounting

Fit

Table 2 shows the recommended fit tolerances for Miniature Linear Bushing. Thickness of external cylinder is very thin. Therefore, when fitting it into the housing, epoxy type adhesive is recommended for fixing the external cylinder in the housing. Do not apply press fitting.

Table 2 Recommended fit tolerance  
(Tolerance of shaft and housing bore) unit :  $\mu\text{m}$

Class \ Item	Shaft	Housing
High class	- 6 - 14	+ 12 0
Precision class	- 4 - 9	+ 8 0

Accessories

Steel shaft for Miniature Linear Bushing

In order to achieve full performance of Miniature Linear Bushing, heat-treated and ground steel shafts with high accuracy and rigidity are available. For details, consult IKO.

Standard : LMS  
High rigidity long : LMSL

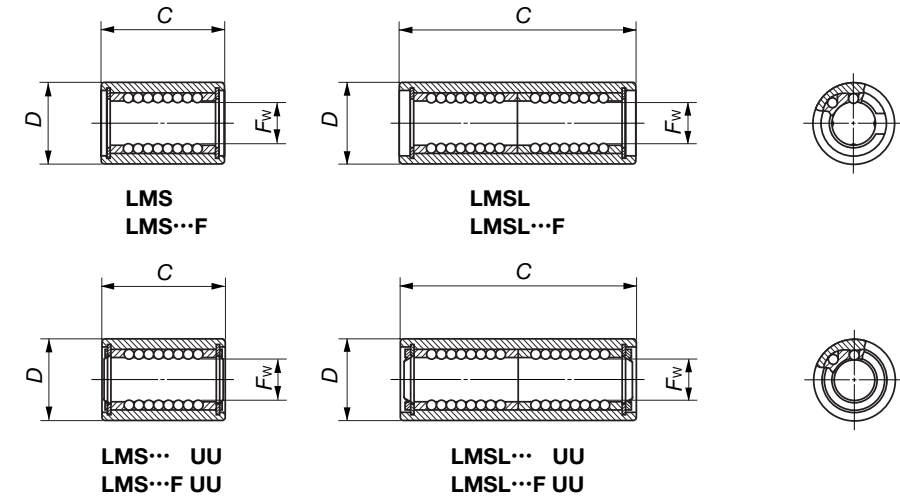

Shaft diameter mm	Model number	Ball circuits	Mass (Ref.) g	Nominal dimensions and tolerances mm						Eccentricity		Basic dynamic load rating C		Basic static load rating Co								
				Fw	Tolerance $\mu\text{m}$		D		C	Tolerance $\mu\text{m}$	Max. $\mu\text{m}$	Pre-precision	High	Load direction A N	Load direction B N	Load direction A N	Load direction B N					
					Pre-precision	High	Pre-precision	High														
3	LMS 3	4	1.8	3	7	10	-120	2	4	18.4	21.2	39.4	55.8	LMS 3 F	0	0	0	0	30.0	34.4	78.9	112
	LMS 3 UU													-5	-8	-7	-8					
	LMS 3 F UU																					
	LMSL 3																					
	LMSL 3 F													-	0	-	0					
	LMSL 3 UU																					
4	LMS 4	4	2.8	4	8	12	-120	2	4	23.5	27.0	48.6	68.7	LMS 4 F	0	0	0	0	38.1	43.8	97.2	137
	LMS 4 UU													-5	-8	-7	-8					
	LMS 4 F UU																					
	LMSL 4																					
	LMSL 4 F													-	0	-	0					
	LMSL 4 UU																					
5	LMS 5	4	3.8	5	10	15	-120	2	4	51.3	59.0	108	152	LMS 5 F	0	0	0	0	83.4	95.8	215	304
	LMS 5 UU													-5	-8	-7	-8					
	LMS 5 F UU																					
	LMSL 5																					
	LMSL 5 F													-	0	-	0					
	LMSL 5 UU																					

Remark : In the tolerance and eccentricity columns, "Precision" refers to precision class and "High" refers to high class.

# Stroke Rotary Bushings

Description of each series and Table of dimensions

E

## Stroke Rotary Bushing

Page E-188 to E-197



## Miniature Stroke Rotary Bushing

Page E-198 to E-205

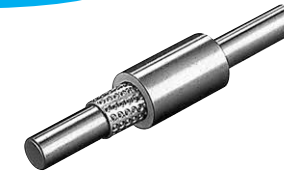

## Stroke Rotary Cage

Page E-206 to E-211

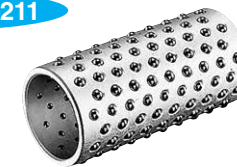

In the table of dimensions, standard products are referred to using identification numbers marked with . The identification numbers marked with  refer to our semi-standard products.

# Stroke Rotary Bushing

ST

**IICO Stroke Rotary Bushing** is a compact linear motion rolling guide capable of rotation as well as linear motion with low frictional resistance. In the external cylinder, steel balls and a retainer are incorporated. Standard and sealed types are available. In both standard and sealed types, ordinary and heavy duty types are available. This series is used in many applications.

## Rotary and linear motion

Steel balls and a retainer are incorporated in an external cylinder having a cylindrical raceway on the inside, so rotary motion can be achieved as well as linear movement.

## Low frictional resistance

Very accurate steel balls are incorporated in a precisely ground external cylinder. So low rolling friction with extremely smooth rotary and reciprocating linear motions can be obtained.

## Small inertia

Since the retainer is highly rigid but light, this series is suitable for high speed rotation and reciprocating movement as inertia is small.

## Standard type Stroke Rotary Bushing

This type is classified into ordinary and heavy duty types depending on the magnitude of load rating. The heavy duty type has a larger load rating and a higher rigidity than the ordinary type, but the stroke length is shorter compared to the ordinary type.

## Sealed type Stroke Rotary Bushing

In this type, synthetic resin seals are incorporated in the external cylinder bore at both ends. These seals are used to prevent intrusion of foreign substances. This type is classified into ordinary and heavy duty types. Both types have shorter stroke lengths compared to the standard type.

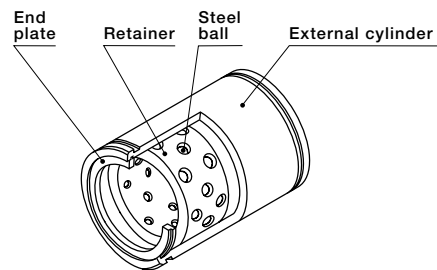

Structure of Stroke Rotary Bushing

## Stroke Rotary Bushing series

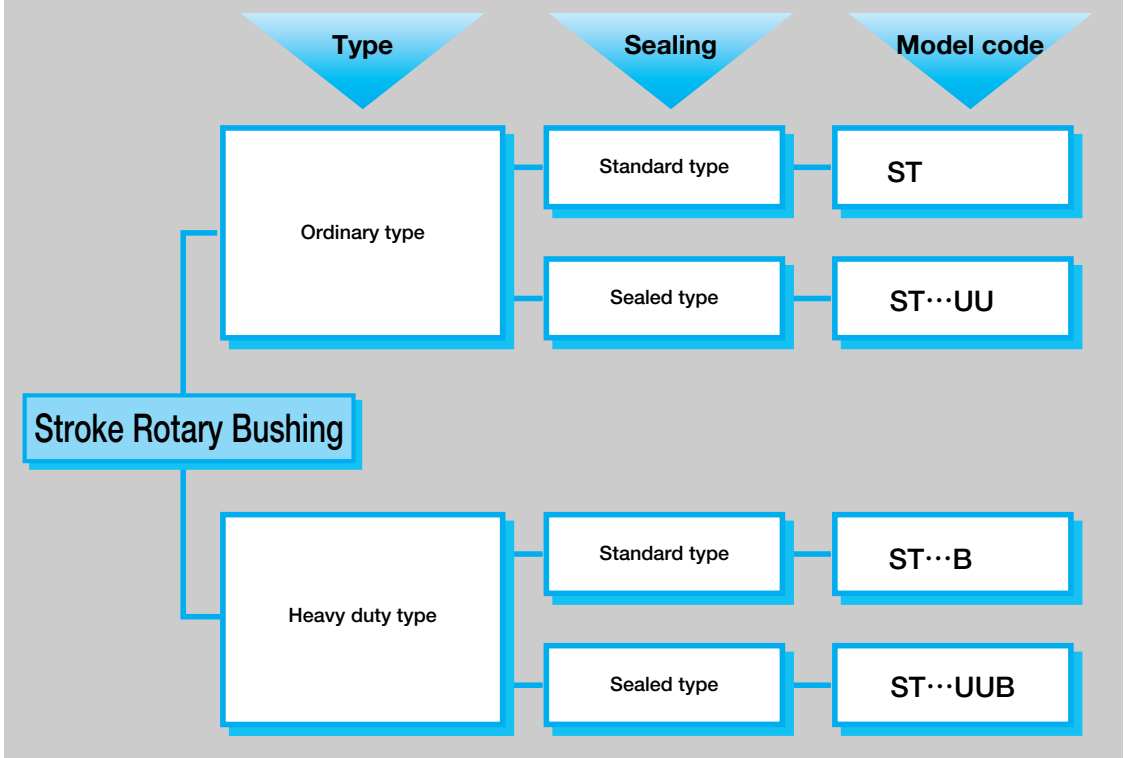

## Identification number and specification

The specification of Stroke Rotary Bushing is indicated by the identification number, consisting of a model code, a size and a part code.

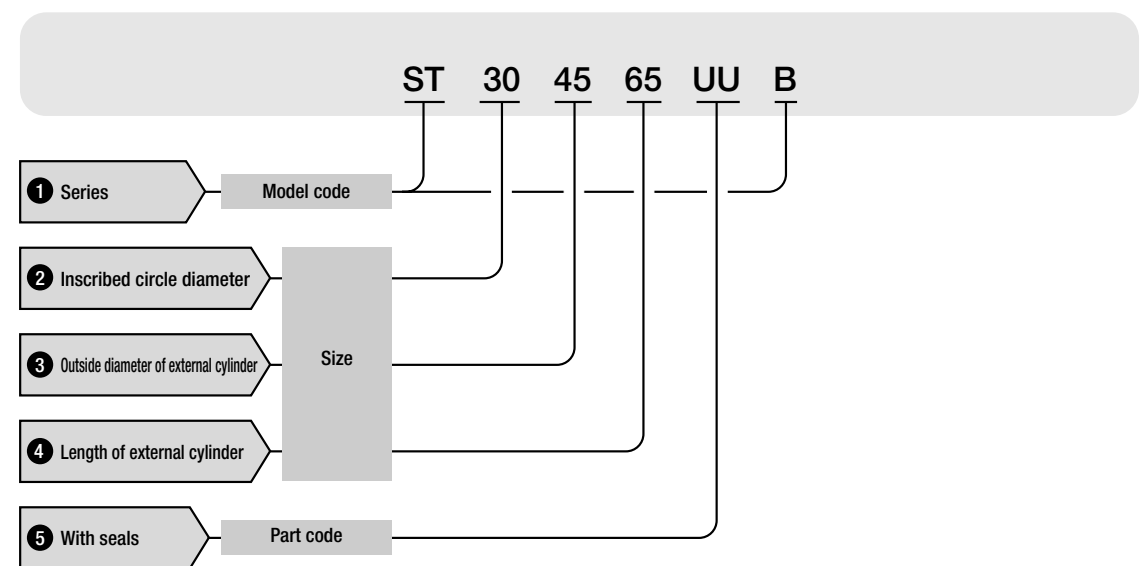

<b>1</b> Series	Ordinary type : <b>ST</b> Heavy duty type : <b>ST···B</b>	The heavy duty type has larger load ratings and higher rigidity but a shorter stroke length than the ordinary type.
<b>2</b> Inscribed circle diameter		Indicate the inscribed circle diameter in mm.
<b>3</b> Outside diameter of external cylinder		Indicate the outside diameter of external cylinder in mm.
<b>4</b> Length of external cylinder		Indicate the length of external cylinder in mm.
<b>5</b> With seals	Standard type : No symbol Sealed type : <b>UU</b>	The sealed type incorporates seals for preventing intrusion of foreign substances. The maximum allowable temperature for seals is 120°C.

## Load Rating

The load ratings of Stroke Rotary Bushing are defined for radial load. Summarized descriptions of load ratings are given below. For details of load rating definitions and load calculations, see "General description".

### ● Basic dynamic load rating $C$

The basic dynamic load rating is defined as the constant radial load both in direction and magnitude under which a group of identical Stroke Rotary Bushings are individually operated and 90% of the units in the group can rotate 1,000,000 revolutions free from material damage due to rolling contact fatigue.

### ● Basic static load rating $C_0$

The basic static load rating is defined as the static radial load that gives a prescribed constant contact stress at the center of the contact area between the rolling element and raceway receiving the maximum load.

## Accuracy

The accuracy of Stroke Rotary Bushing is shown in Tables 1.1 and 1.2. The outside diameter of external cylinder changes by the tension of the stop ring to be set with the external cylinder. Accordingly, the measurement of the outside diameter should be made at the measuring position obtained from formula (1), and the mean diameter at that position is used.

$$W = 4 + L_1 / 8 \dots \dots \dots (1)$$

where,  $W$ : Distance from the end face to measuring position  $P$ , mm (See Fig. 1.)

$L_1$ : Length of external cylinder, mm

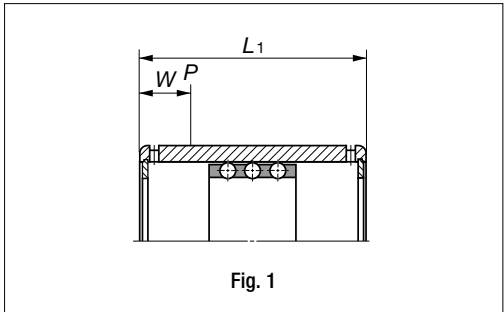

**Table 1.1 Tolerance of inscribed circle diameter and outside diameter of external cylinder unit :  $\mu\text{m}$**

Inscribed circle diameter $F_w$ or outside diameter $D$ of external cylinder mm		Tolerance of inscribed circle diameter $F_w$		Tolerance of outside diameter of external cylinder $D_m^{(1)}$	
		high	low	high	low
over	incl.				
4	6	+18	+10	—	—
6	10	+22	+13	0	- 8
10	18	+27	+16	0	- 8
18	30	+33	+20	0	- 9
30	50	+41	+25	0	-11
50	80	+49	+30	0	-13
80	120	+58	+36	0	-15
120	150	—	—	0	-18

Note<sup>(1)</sup> :  $D_m$  is an arithmetic mean value of maximum and minimum outside diameters obtained by two-point measurement method.

**Table 1.2 Tolerance of length of external cylinder unit :  $\mu\text{m}$**

Inscribed circle diameter $F_w$ mm		Tolerance of length $L_1$ of external cylinder	
		high	low
over	incl.		
—	20	0	-200
20	60	0	-300
60	100	0	-400

## Fit

The fit of Stroke Rotary Bushing with shaft and housing bore is recommended to be as shown in Table 2. Since both rotary and linear motions may be performed at the same time, radial clearance should be held to minimum if shock load is applied or vibration is present during the operation. For use on a vertical axis or when very accurate movement is required, zero clearance or minimal preload is recommended. However, since excessive preload shortens life, radial clearance smaller than the values shown in Table 3 should not be used.

Operating condition	Tolerance range class	
	Shaft	Housing bore
General application	k5, m5	H6, H7
Vertical axis or high accuracy	n5, p6	J6, J7

Inscribed circle diameter $F_w$ mm		Minimum value of radial clearance
over	incl.	
4	6	- 2
6	10	- 3
10	18	- 4
18	30	- 5
30	50	- 6
50	80	- 8
80	100	-10

## Allowable Limit of Speed

Stroke Rotary Bushing can operate in both linear and rotary directions at the same time. The allowable limit of speed when linear motion and rotation occur at the same time can be obtained from the following formula. Limiting values in general are shown in Table 4.

$$DN \geq D_{pw} n + 10S n_1 \dots\dots\dots(2)$$

where,  $DN$ : Limit of speed (See Table 4.)

$n$ : Number of revolutions per minute, rpm

$n_1$ : Number of strokes per minute, cpm

$S$ : Stroke length, mm

$D_{pw}$ : Pitch circle diameter of balls, mm ( $D_{pw} \doteq 1.15 F_w$ )

$F_w$ : Inscribed circle diameter, mm

This formula is applicable only when  $n_1 \leq 5000$  and  $Sn_1 \leq 50000$ .

Lubrication	$DN$
Oil	600 000
Grease	300 000

## Precautions for Use

- 1 Actual stroke length should be less than 80% of the maximum stroke length shown in the dimension tables.
- 2 Since Stroke Rotary Bushings operate with a shaft as a raceway surface, the shaft should be heat-treated and ground. Recommended surface hardness and roughness of the shaft are shown in Table 5, and also recommended minimum effective hardening depth of the raceway is shown in Table 6.
- 3 This series can be used with oil or grease lubrication. A good quality lithium-soap base grease is recommended for grease lubrication. Lubrication is done through oil holes provided on the external cylinder.

Item	Recommended value	Remarks
Surface hardness	58~64HRC	When the raceway hardness is less than the necessary hardness, multiply load ratings by the hardness factor.
Surface roughness	0.2 $\mu$ mRa or better (0.8 $\mu$ mRy or better)	When the required accuracy is not severe, a surface roughness of about 0.8 $\mu$ mRa (3.2 $\mu$ mRy) is adequate.

Shaft diameter		Recommended minimum effective hardening depth
over	incl.	
-	28	0.8
28	50	1.0
50	100	1.5

## Precautions for Mounting

First, assemble Stroke Rotary Bushing into a housing. Then gradually and gently insert a shaft into a bore. At this time, be careful not to give impact on the steel balls. After Stroke Rotary Bushing is assembled with a shaft and housing, the retainer must be located at the center of the axial direction of the external cylinder. In this process, insert the shaft into the bore, and the retainer will move together with the shaft and then stop at the end of external cylinder. Push in the shaft further for the distance of 1/2 of the maximum stroke length shown in the dimension tables while paying attention not to damage the steel balls and raceways. Pull back the shaft for the distance of 1/2 of the maximum stroke length. The retainer should then be positioned at the center of the axial direction of the external cylinder.

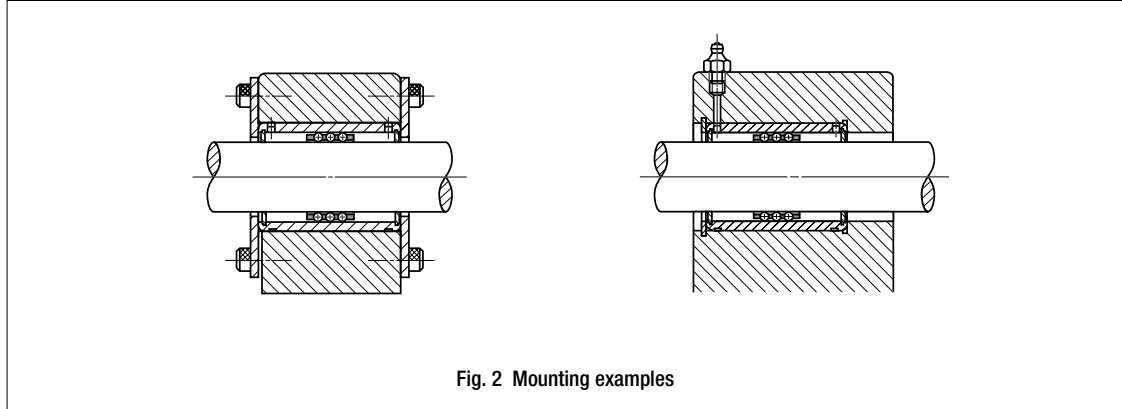
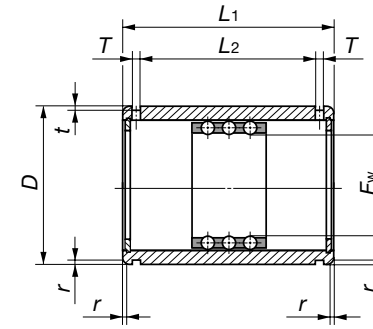

Fig. 2 Mounting examples

# IKO Stroke Rotary Bushing

Ordinary type : ST  
Heavy duty type : ST...B



ST

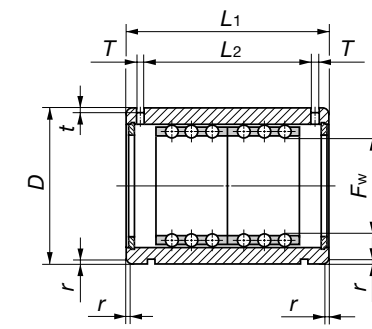

ST...B

Shaft diameter mm	Model number				Nominal dimensions mm			
	Ordinary type	Mass (Ref.) g	Heavy duty type	Mass (Ref.) g	$F_w$	$D$	$L_1$	$L_2$
4	ST 4814	2.9	—	—	4	8	14	9
5	ST 51016	5.6	—	—	5	10	16	10.6
6	ST 61219	8.9	—	—	6	12	19	13.2
8	ST 81524	15.6	ST 81524B	16.8	8	15	24	17.1
10	ST 101930	28.8	ST 101930B	31.2	10	19	30	22.7
12	ST 122332	42	ST 122332B	46	12	23	32	24.5
16	ST 162837	71	ST 162837B	75	16	28	37	29.1
20	ST 203245	99	ST 203245B	106	20	32	45	35.8
25	ST 253745	117	ST 253745B	125	25	37	45	35.8
30	ST 304565	205	ST 304565B	220	30	45	65	53.5
35	ST 355270	329	ST 355270B	346	35	52	70	58.5
40	ST 406080	516	ST 406080B	540	40	60	80	68.3
45	ST 456580	563	ST 456580B	588	45	65	80	68.3
50	ST 5072100	827	ST 5072100B	862	50	72	100	86.4
55	ST 5580100	1 160	ST 5580100B	1 200	55	80	100	86.4
60	ST 6085100	1 240	ST 6085100B	1 290	60	85	100	86.4
70	ST 7095100	1 400	ST 7095100B	1 450	70	95	100	86.4
80	ST 80110100	2 050	ST 80110100B	2 110	80	110	100	86
90	ST 90120100	2 250	ST 90120100B	2 330	90	120	100	86
100	ST 100130100	2 440	ST 100130100B	2 520	100	130	100	86

$T$	$t$	$r$	ST			ST...B		
			Maximum stroke length mm	Basic dynamic load rating C N	Basic static load rating C <sub>0</sub> N	Maximum stroke length mm	Basic dynamic load rating C N	Basic static load rating C <sub>0</sub> N
1.1	0.25	0.3	10	112	59.5	—	—	—
1.1	0.25	0.3	13	121	68.3	—	—	—
1.1	0.25	0.3	15	278	168	—	—	—
1.5	0.5	0.5	24	315	211	8	512	422
1.5	0.5	0.5	30	659	466	8	1 070	932
1.5	0.5	0.5	32	1 110	822	8	1 800	1 640
1.5	0.5	0.5	40	1 230	998	16	1 990	2 000
2	0.5	0.5	54	1 390	1 250	28	2 250	2 500
2	0.5	1	54	1 450	1 430	28	2 360	2 850
2.5	0.5	1	82	3 110	3 160	44	5 060	6 320
2.5	0.7	1.5	92	3 290	3 550	54	5 340	7 100
2.5	0.7	1.5	108	4 340	4 810	66	7 050	9 630
2.5	0.7	1.5	108	4 550	5 330	66	7 390	10 700
3	1	1.5	138	5 790	6 970	88	9 400	13 900
3	1	2	138	6 030	7 630	88	9 800	15 300
3	1	2	138	6 260	8 300	88	10 200	16 600
3	1	2	138	6 510	9 320	88	10 600	18 600
3	1.5	2	132	8 230	12 200	76	13 400	24 400
3	1.5	2	132	8 550	13 500	76	13 900	27 000
3	1.5	2	132	8 820	14 800	76	14 300	29 500

# IKO Sealed type Stroke Rotary Bushing

Ordinary type : ST...UU  
Heavy duty type : ST...UUB

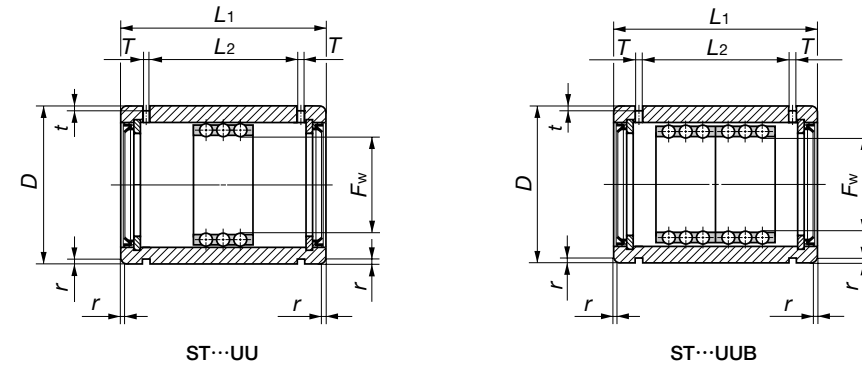

Shaft diameter mm	Model number				Nominal dimensions mm			
	Ordinary type	Mass (Ref.) g	Heavy duty type	Mass (Ref.) g	$F_w$	$D$	$L_1$	$L_2$
8	ST 81524UU	16.5	—	—	8	15	24	12.3
10	ST 101930UU	30.7	—	—	10	19	30	15.5
12	ST 122332UU	45	—	—	12	23	32	17.1
16	ST 162837UU	74	—	—	16	28	37	21.1
20	ST 203245UU	107	—	—	20	32	45	26.8
25	ST 253745UU	121	—	—	25	37	45	26.8
30	ST 304565UU	215	ST 304565UUB	230	30	45	65	45.1
35	ST 355270UU	342	ST 355270UUB	359	35	52	70	50.1
40	ST 406080UU	529	ST 406080UUB	553	40	60	80	59.9
45	ST 456580UU	577	ST 456580UUB	602	45	65	80	59.9
50	ST 5072100UU	836	ST 5072100UUB	871	50	72	100	77.4
55	ST 5580100UU	1 190	ST 5580100UUB	1 230	55	80	100	77.4
60	ST 6085100UU	1 270	ST 6085100UUB	1 320	60	85	100	77.4
70	ST 7095100UU	1 430	ST 7095100UUB	1 480	70	95	100	77.4
80	ST 80110100UU	2 080	ST 80110100UUB	2 140	80	110	100	77
90	ST 90120100UU	2 290	ST 90120100UUB	2 370	90	120	100	77
100	ST 100130100UU	2 540	ST 100130100UUB	2 620	100	130	100	77

$T$	$t$	$r$	ST...UU			ST...UUB		
			Maximum stroke length mm	Basic dynamic load rating C N	Basic static load rating $C_0$ N	Maximum stroke length mm	Basic dynamic load rating C N	Basic static load rating $C_0$ N
1.5	0.5	0.5	14	315	211	—	—	—
1.5	0.5	0.5	16	659	466	—	—	—
1.5	0.5	0.5	17	1 110	822	—	—	—
1.5	0.5	0.5	24	1 230	998	—	—	—
2	0.5	0.5	32	1 390	1 250	—	—	—
2	0.5	1	32	1 450	1 430	—	—	—
2.5	0.5	1	65	3 110	3 160	27	5 060	6 320
2.5	0.7	1.5	75	3 290	3 550	37	5 340	7 100
2.5	0.7	1.5	91	4 340	4 810	49	7 050	9 630
2.5	0.7	1.5	91	4 550	5 330	49	7 390	10 700
3	1	1.5	120	5 790	6 970	70	9 400	13 900
3	1	2	120	6 030	7 630	70	9 800	15 300
3	1	2	120	6 260	8 300	70	10 200	16 600
3	1	2	120	6 510	9 320	70	10 600	18 600
3	1.5	2	114	8 230	12 200	58	13 400	24 400
3	1.5	2	114	8 550	13 500	58	13 900	27 000
3	1.5	2	114	8 820	14 800	58	14 300	29 500



# Miniature Stroke Rotary Bushing

## STSI

**IKO Miniature Stroke Rotary Bushing** is a very compact linear motion rolling guide with small diameter and low sectional height. It is able to achieve both rotary and linear motion at the same time. Since Miniature Stroke Rotary Bushing is extremely small in size and features high accuracy and low frictional resistance, it is suitable for applications which require compact size with high accuracy such as measuring instruments, IC manufacturing machines and precision equipment.

### Rotary and linear motion

Steel balls held in a retainer are assembled into an outer ring having a cylindrical raceway on the inside, so linear motion as well as rotary movement can be achieved.

### Extremely compact size

Very small diameter steel balls are assembled in a very thin walled outer ring. So the assembled set is extremely compact in sectional height.

### Extremely accurate

The outer ring and shaft are precisely super-finished after heat treatment. The assembled set, which consists of an outer ring, shaft and very precise steel balls held in a retainer, is set to zero or minimal preload. So extremely accurate operation can be achieved both in rotary and linear motion.

### Very smooth movement

All parts are precisely finished and assembled to obtain an optimal preload. This series offers very smooth and stable movement as well as high accuracy with low frictional resistance.

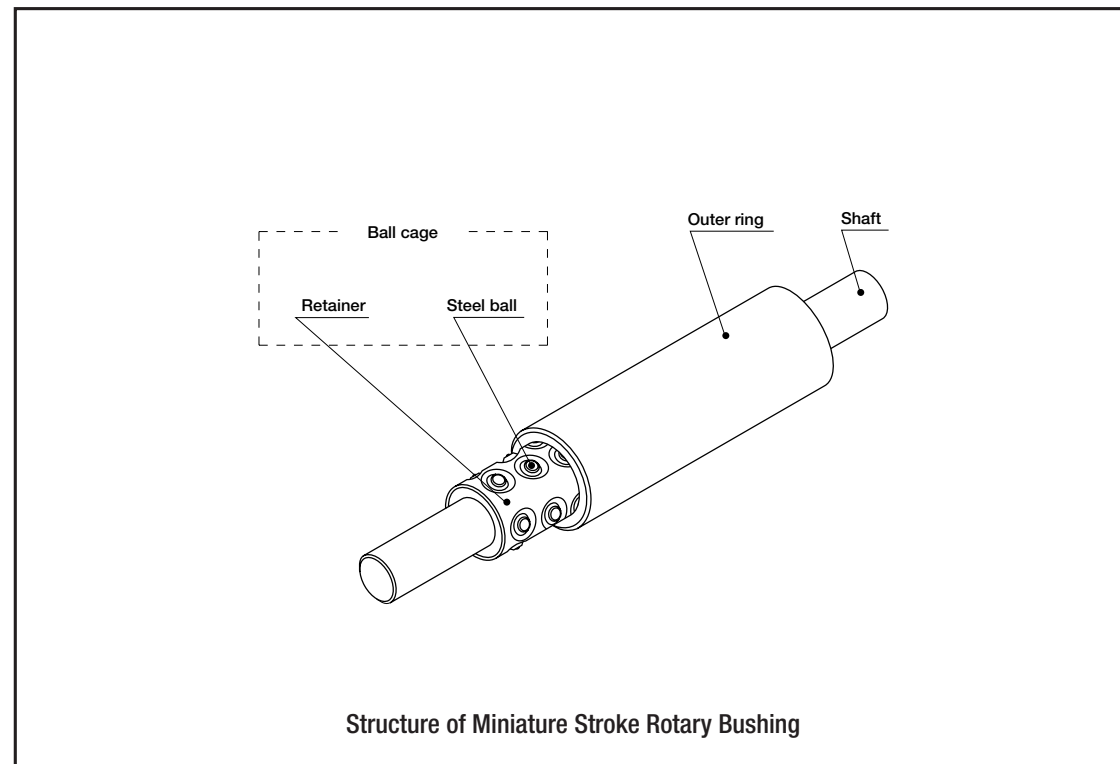

## Miniature Stroke Rotary Bushing series

Assembled set

Parts

Miniature Stroke Rotary Bushing with shaft: STSI



Outer ring: OR···A



Ball cage: BK···A



Miniature Stroke Rotary Bushing without shaft: STS



Shaft: SF···A



## ● Identification number and specification

The specification of Miniature Stroke Rotary Bushing is indicated by the identification number, consisting of a model code, a size, a length and a selection code.

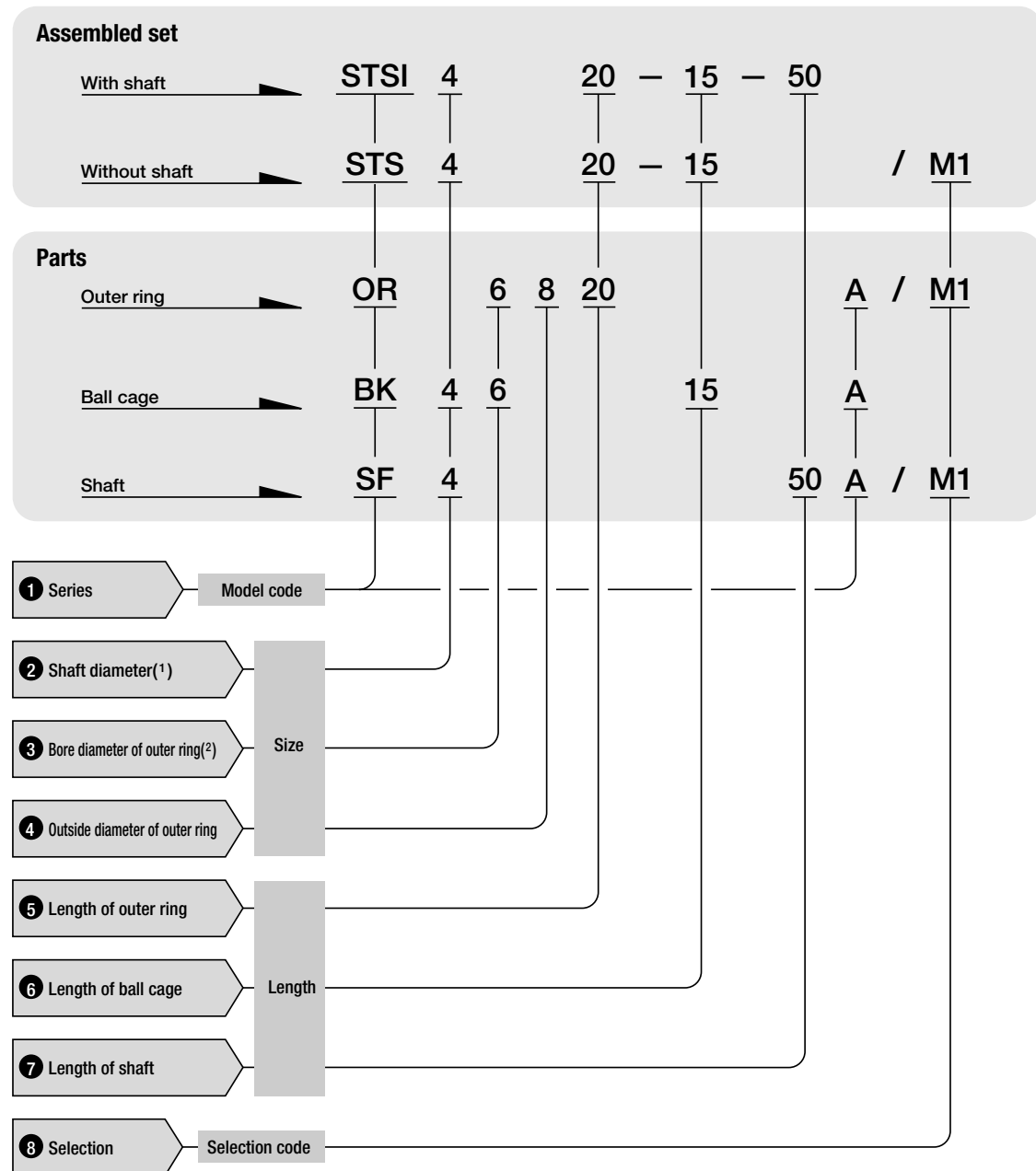

Note<sup>(1)</sup> : For an assembled set without shaft and for a ball cage, this item indicates an inscribed circle diameter.  
<sup>(2)</sup> : For a ball cage, this item indicates a circumscribed circle diameter.

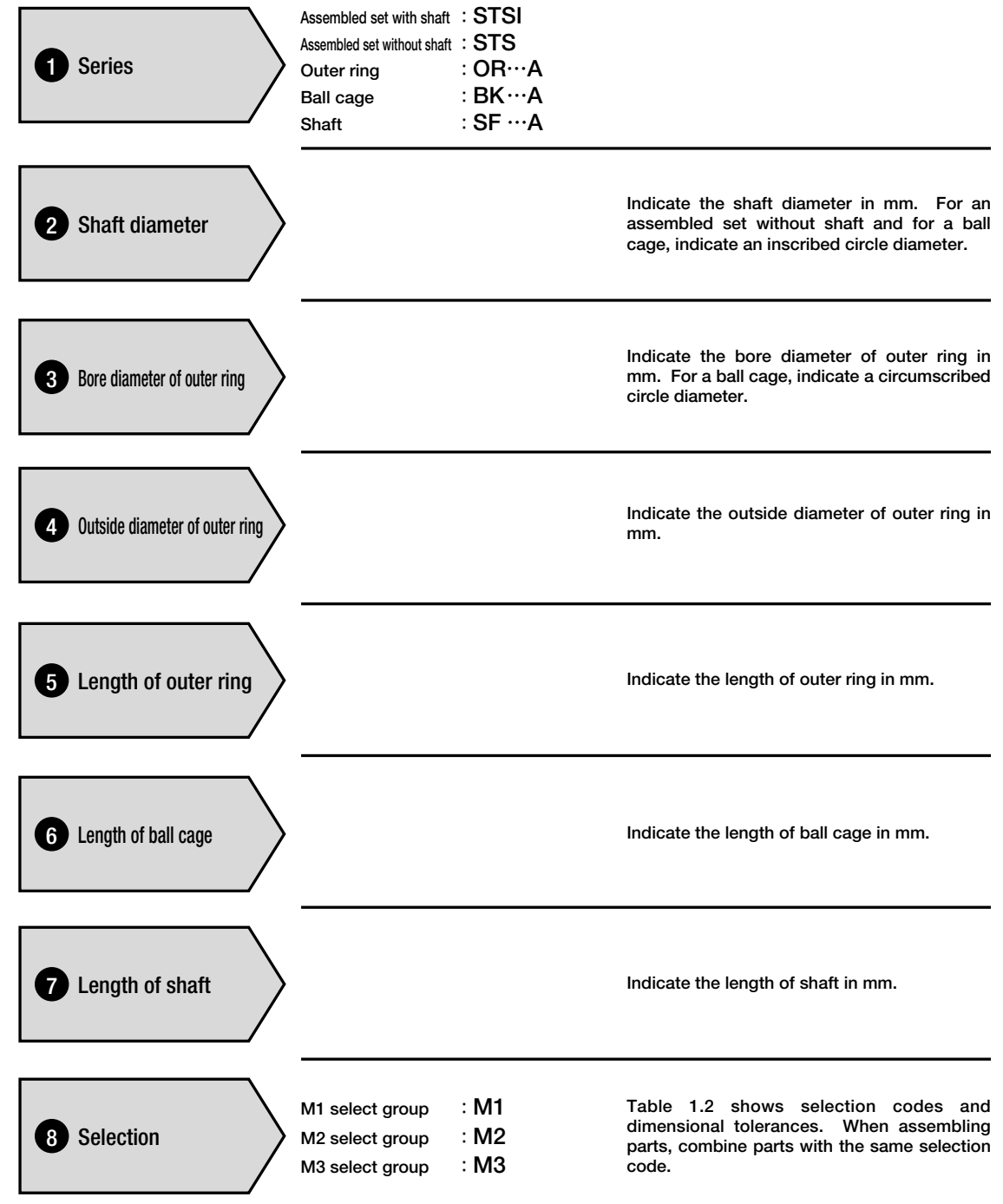

## Load Rating

The load ratings of Miniature Stroke Rotary Bushing are defined for radial load. Summarized descriptions of load ratings are given below. For details of load rating definitions and load calculations, see "General description".

The load rating of Miniature Stroke Rotary Bushing is given for the case when the steel balls assembled in a retainer are positioned within the outer ring raceway without escaping from it and equally share an applied load.

### Basic static load rating $C_0$

The basic static load rating is defined as the static radial load that gives a prescribed constant contact stress at the center of the contact area between the rolling element and raceway receiving the maximum load.

## Accuracy

The accuracy of Miniature Stroke Rotary Bushing is shown below.

Table 1.1 Accuracy

Outside diameter of outer ring mm		Tolerance of outside diameter of outer ring $\mu\text{m}$		Maximum radial runout of outside diameter of outer ring $\mu\text{m}$	Tolerance of length of outer ring and shaft mm
over	incl.	high	low		
3	6	0	-5	8	$\pm 0.1$
6	10	0	-6		
10	18	0	-8		
18	30	0	-9	9	

Table 1.2 Selection codes and dimensional tolerances unit :  $\mu\text{m}$

Selection code	Tolerance of outer ring bore		Tolerance of inscribed circle diameter		Tolerance of shaft diameter	
	high	low	high	low	high	low
M1	-1	-3	-1	-3	0	-1
M2	-2	-4	-2	-4	-1	-2
M3	-3	-5	-3	-5	-2	-3

## Fit

Miniature Stroke Rotary Bushing is set to minimal preload condition to obtain high operating accuracy. For Miniature Stroke Rotary Bushing with shaft, a slight clearance fit between the outer ring and the housing is recommended to avoid any undesirable influence on the inscribed circle diameter.

Also, when assembling the outer ring, ball cage and shaft, select the outer ring and shaft which have the same selection code and match them to a ball cage.

## Precautions for Use

- 1 The outer ring should have a clearance fit in the housing. When the outer ring must be positioned in the axial direction with the housing, use a stop ring, etc. at the end of the outer ring or use synthetic adhesive.
- 2 When inserting a shaft into a ball cage, the ball cage must be located at the center of the axial direction of the outer ring. A convenient way of locating the ball cage is to shift the position of the ball cage prior to assembly to the inserting direction for the distance of 1/2 of the inserting distance of the shaft.
- 3 When inserting the shaft into a ball cage, be careful not to damage the steel balls and raceways by twisting the shaft or applying a shock load.
- 4 Miniature Stroke Rotary Bushing can be used with oil or grease lubrication. When lubricating with grease, the grease is usually lightly smeared on the raceways of the shaft and outer ring. A good quality lithium-soap base grease is recommended.

# IKO Miniature Stroke Rotary Bushing

- Assembled set with shaft : **STSI**
- Assembled set without shaft : **STS**
- Outer ring : **OR...A**
- Ball cage : **BK...A**
- Shaft : **SF ...A**

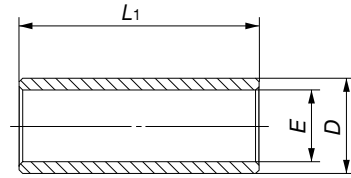

Outer ring

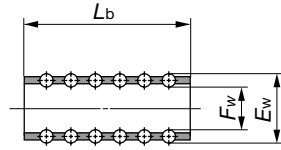

Ball cage

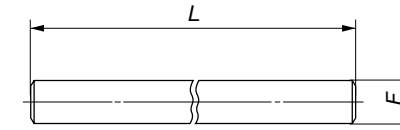

Shaft

Shaft diameter mm	Model number of the assembled set without shaft	Outer ring					Ball cage		
		Identification number	Mass (Ref.) g	Nominal dimension mm			Identification number	Mass (Ref.) g	F <sub>w</sub>
				E	D	L <sub>1</sub>			
2	STS 2 L <sub>1</sub> -L <sub>b</sub>	OR 3 5 10 A	0.9	3.2	5	10	BK 2 3 5 A	0.1	2
		OR 3 5 15 A	1.3				BK 2 3 10 A	0.3	
3	STS 3 L <sub>1</sub> -L <sub>b</sub>	OR 5 7 10 A	1.5	5	7	10	BK 3 5 10 A	0.7	3
		OR 5 7 20 A	2.9				BK 3 5 15 A	1.1	
		OR 5 7 30 A	4.4				BK 3 5 20 A	1.4	
4	STS 4 L <sub>1</sub> -L <sub>b</sub>	OR 6 8 10 A	1.7	6	8	10	BK 4 6 10 A	0.9	4
		OR 6 8 20 A	3.4				BK 4 6 15 A	1.3	
		OR 6 8 30 A	5.2				BK 4 6 20 A	1.8	
5	STS 5 L <sub>1</sub> -L <sub>b</sub>	OR 7 10 10 A	3.1	7	10	10	BK 5 7 10 A	1.0	5
		OR 7 10 20 A	6.3				BK 5 7 15 A	1.6	
		OR 7 10 30 A	9.4				BK 5 7 20 A	2.0	
6	STS 6 L <sub>1</sub> -L <sub>b</sub>	OR 8 11 20 A	7.0	8	11	20	BK 6 8 10 A	1.2	6
		OR 8 11 30 A	10.5				BK 6 8 15 A	1.8	
		OR 8 11 40 A	14.1				BK 6 8 20 A	2.3	
8	STS 8 L <sub>1</sub> -L <sub>b</sub>	OR 10 13 20 A	8.5	10	13	20	BK 8 10 10 A	1.6	8
		OR 10 13 30 A	12.7				BK 8 10 15 A	2.4	
		OR 10 13 40 A	17.0				BK 8 10 20 A	3.2	
10	STS 10 L <sub>1</sub> -L <sub>b</sub>	OR 12 18 20 A	22.2	12	18	20	BK 10 12 15 A	2.8	10
		OR 12 18 30 A	33.3				BK 10 12 20 A	3.8	
		OR 12 18 43 A	47.7				BK 10 12 25 A	4.8	
12	STS 12 L <sub>1</sub> -L <sub>b</sub>	OR 14 20 25 A	31.4	14	20	25	BK 12 14 20 A	4.3	12
		OR 14 20 30 A	37.7				BK 12 14 25 A	5.4	
		OR 14 20 35 A	44.0				BK 12 14 30 A	6.1	
		OR 14 20 40 A	50.3						

Nominal dimensions mm		Basic static load rating <sup>(1)</sup> C <sub>0</sub> N	Shaft				Model number of the assembled set with shaft
E <sub>w</sub>	L <sub>b</sub>		Identification number	Mass (Ref.) g	Nominal dimensions mm		
						F	L
3.2	5	10.5	SF 2 20 A	0.5	2	20	STSI 2 L <sub>1</sub> -L <sub>b</sub> -L
	10	21.0	SF 2 30 A	0.7			
5	10	38.4	SF 3 50 A SF 3 60 A	2.8	3	50	STSI 3 L <sub>1</sub> -L <sub>b</sub> -L
	15	57.7		3.3			
	20	76.9					
6	10	59.5	SF 4 50 A SF 4 60 A	4.9	4	50	STSI 4 L <sub>1</sub> -L <sub>b</sub> -L
	15	89.3		5.9			
	20	119					
7	10	81	SF 5 50 A SF 5 80 A	7.7	5	50	STSI 5 L <sub>1</sub> -L <sub>b</sub> -L
	15	121		12.3			
	20	162					
8	10	103	SF 6 50 A SF 6 80 A	11.1	6	50	STSI 6 L <sub>1</sub> -L <sub>b</sub> -L
	15	154		17.7			
	20	206					
10	10	105	SF 8 50 A SF 8 80 A SF 8 90 A	19.7	8	50	STSI 8 L <sub>1</sub> -L <sub>b</sub> -L
	15	157		31.5			
	20	209		35.5			
12	15	191	SF 10 80 A SF 10 100 A SF 10 120 A	49.3	10	80	STSI 10 L <sub>1</sub> -L <sub>b</sub> -L
	20	254		61.6			
	25	318		74.0			
14	20	341	SF 12 80 A SF 12 100 A SF 12 120 A	71.0	12	80	STSI 12 L <sub>1</sub> -L <sub>b</sub> -L
	25	427		88.8			
	30	512		106.5			

Note<sup>(1)</sup>: This figure shows the static load rating when the steel balls assembled in a retainer do not escape from the raceway of outer ring and the balls equally share an applied load.

Remark: "L<sub>1</sub>", "L<sub>b</sub>" and "L" in the model number of the assembled set - either with shaft or without shaft - indicate "length of outer ring", "length of ball cage" and "shaft length" respectively.

# Stroke Rotary Cage

## BG

**IKO Stroke Rotary Cage is a compact linear motion rolling guide with low sectional height. Steel balls having very small size variation in diameter are held in a retainer. Thus if they are assembled with a shaft and housing which are precisely finished to function as raceways, reciprocal linear motion as well as rotation can be achieved with high accuracy corresponding to the accuracy of the shaft and housing.**

### Superior high speed performance

The retainers are highly rigid and light in weight with low inertia. So this series is suitable for high speed reciprocating linear motion.

### Long life

The steel balls held in the retainer are arranged in a spiral formation in order to prevent the steel balls tracing the same path. Rolling contact fatigue of the shaft and housing raceways is thereby minimized. Also, stable high accuracy can be assured for long periods of time.

### Large load rating and high rigidity

In the retainer, steel balls are incorporated as many as possible. So the load ratings are large and the rigidity is high with small elastic deformation even under fluctuating loads or localized edge loads.

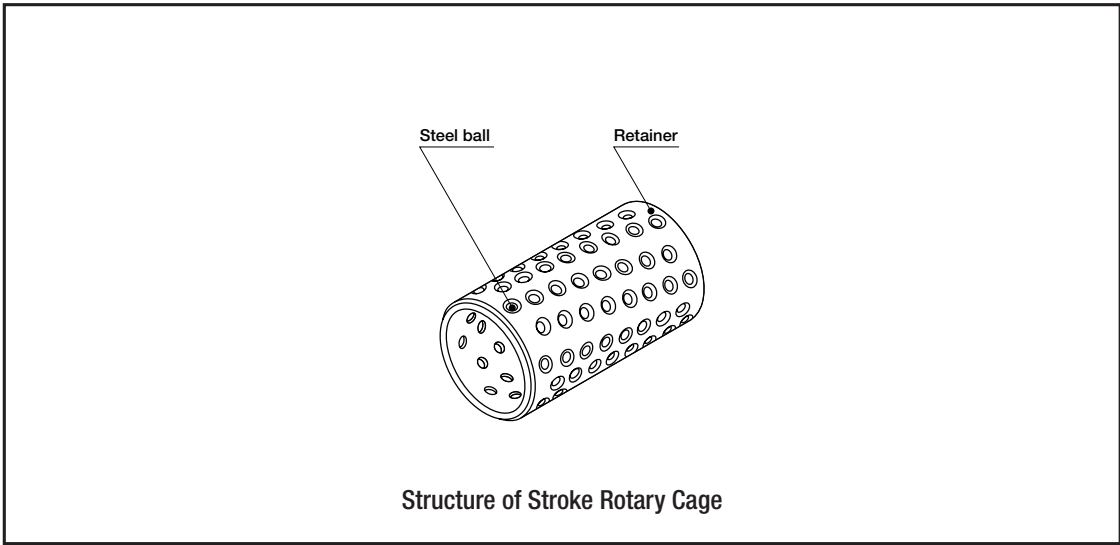

### Identification number and specification

The identification number of Stroke Rotary Cage consists of a model code and a size. An example of identification number is shown below.

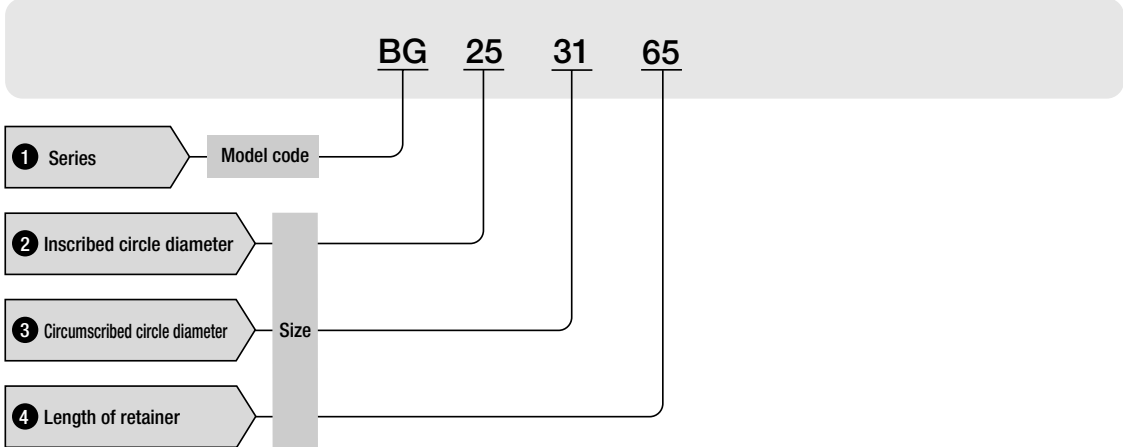

1 Series	BG
2 Incribed circle diameter	Indicate the inscribed circle diameter in mm.
3 Circumscribed circle diameter	Indicate the circumscribed circle diameter in mm.
4 Length of retainer	Indicate the length of retainer in mm.

## Load Rating

The load ratings of Stroke Rotary Cage are defined for radial load. Summarized descriptions of load ratings are given below. For details of load rating definitions and load calculations, see "General description".

### ● Basic dynamic load rating *C*

The basic dynamic load rating is defined as the constant radial load both in direction and magnitude under which a group of identical Stroke Rotary Cages are individually operated and 90% of the units in the group can rotate 1,000,000 revolutions free from material damage due to rolling contact fatigue.

### ● Basic static load rating *C<sub>0</sub>*

The basic static load rating is defined as the static radial load that gives a prescribed constant contact stress at the center of the contact area between the rolling element and raceway receiving the maximum load.

## Fit

Stroke Rotary Cage is generally used with a minimal radial clearance. Recommended fits are shown in Table 1.

If Stroke Rotary Cage is used on the die-set guiding posts of press machines or on machines which require accurate operation, a preload is generally given. In this case, the dimensional accuracy of the shaft and housing bore is recommended as shown in Table 2. However, since excessive preload shortens the life of Stroke Rotary Cage, it is suggested that the lower limit of radial clearance is not smaller than the value shown in Table 3.

**Table 1 Fit in general**

Shaft	Housing bore
h5, h6	H6, H7

**Table 2 Dimensional accuracy of shaft and housing bore**  
unit :  $\mu\text{m}$

Nominal diameter mm	Shaft		Housing bore		
	h5		Nominal diameter mm	K5	
	high	low		high	low
19	0	-9	25	+1	-8
22	0	-9	28	+1	-8
25	0	-9	31	+2	-9
28	0	-9	36	+2	-9
32	0	-11	40	+2	-9
38	0	-11	48	+2	-9

**Table 3 Lower limit of radial clearance**  
unit :  $\mu\text{m}$

Nominal shaft diameter mm	Lower limit of radial clearance
19	-5
22	-5
25	-5
28	-7
32	-7
38	-7

## Allowable Limit of Speed

Stroke Rotary Cages can be operated in both linear and rotary directions at the same time. The allowable limit of speed when linear motion and rotation occur at the same time can be obtained from the following formula. Limiting values in general are shown in Table 4.

$$DN \geq D_{pw} n + 10S n_1 \dots \dots \dots (1)$$

- where, *DN*: Limit of speed (See Table 4.)  
*n*: Number of revolutions per minute, rpm  
*n<sub>1</sub>*: Number of strokes per minute, cpm  
*S*: Stroke length, mm  
*D<sub>pw</sub>*: Pitch circle diameter of balls, mm (  $D_{pw} = \frac{F_w + E_w}{2}$  )  
*F<sub>w</sub>*: Inscribed circle diameter, mm  
*E<sub>w</sub>*: Circumscribed circle diameter, mm

**Table 4 Limit of speed**

Lubrication	DN
Oil	600 000
Grease	300 000

This formula is applicable only when  $n_1 \leq 5000$  and  $S n_1 \leq 50000$ .

## Precautions for Use

① Stroke Rotary Cage is used with a shaft and housing bore as raceway surfaces. Recommended surface hardness and roughness of the shaft and housing are shown in Table 5, and also recommended minimum effective hardening depth of the raceway is shown in Table 6.

**Table 5 Surface hardness and roughness of raceways**

Item	Recommended value	Remarks
Surface hardness	58~64HRC	When the raceway hardness is less than the necessary hardness, multiply load ratings by the hardness factor.
Surface roughness	0.2 $\mu\text{mRa}$ or better (0.8 $\mu\text{mRy}$ or better)	When the required accuracy is not severe, a surface roughness of about 0.8 $\mu\text{mRa}$ (3.2 $\mu\text{mRy}$ ) is adequate.

**Table 6 Minimum effective hardening depth**  
unit : mm

Shaft or housing bore diameter	Recommended minimum effective hardening depth	
	over	incl.
—	28	0.8
28	50	1.0

② Stroke Rotary Cage can be used with oil or grease lubrication. A good quality lithium-soap base grease is recommended for grease lubrication.

③ When Stroke Rotary Cage is operated in a linear direction and some of the steel balls escape the housing raceway, it is recommended that the housing bore ends should be slightly tapered so that the balls enter or exit smoothly.

BG

Precautions for Mounting

- 1 First, assemble Stroke Rotary Cage into a housing. Then gradually and gently insert a shaft into a bore. During assembly, keep the shaft parallel to the axis of Stroke Rotary Cage and avoid giving impact on the steel balls.
- 2 When Stroke Rotary Cage is used in a preloaded condition, position the ball cage at the regular position in the axial direction. A convenient way for positioning is to shift the position of the ball cage prior to the assembly to the inserting direction for the distance of 1/2 of the inserting distance of the shaft.

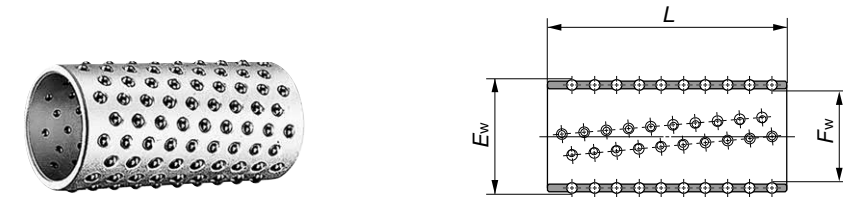
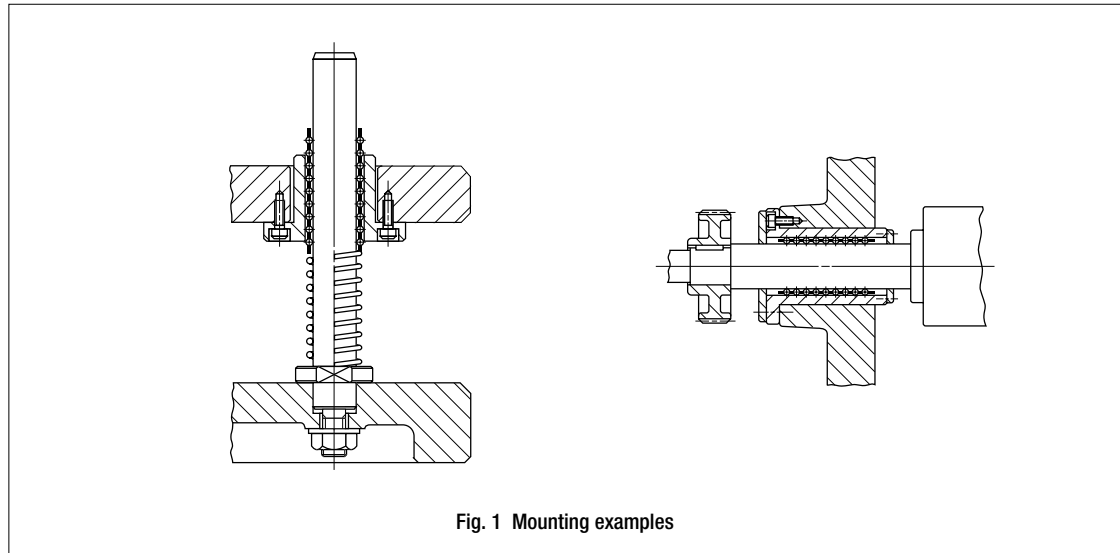

Shaft diameter mm	Model number	Mass (Ref.) g	Nominal dimensions mm			Basic dynamic load rating C N	Basic static load rating C <sub>0</sub> N
			F <sub>w</sub>	E <sub>w</sub>	L		
19	BG 192555	33	19	25	55	2 330	2 600
22	BG 222860	40	22	28	60	2 490	2 950
25	BG 253165	48	25	31	65	2 660	3 390
28	BG 283670	76	28	36	70	3 830	4 660
32	BG 324075	93	32	40	75	4 480	6 030
38	BG 384880	162	38	48	80	6 750	9 390

Remark : The values of basic dynamic load rating and basic static load rating are the values when the steel balls assembled in a retainer do not escape from the raceways and the applied load is equally distributed on the balls.

# Roller Ways and Flat Roller Cages

Description of each series and Table of dimensions

E

## Flat Roller Cage

Page E-214 to E-225



In the table of dimensions, standard products are referred to using identification numbers marked with  . The identification numbers marked with   refer to our semi-standard products.



# Flat Roller Cage

FT/FTW...A

**IICO Flat Roller Cage** is a precision linear motion rolling guide consisting of a high accuracy cage and very precise rollers and features very low sectional height. In this series, both single row type and double row type with a 90° angle are available. The cage material is steel or synthetic resin.

## Smooth operation

As the cage precisely guides the rollers, the frictional resistance is very low without stick-slip, and stable linear motion is obtained.

## Low noise

Cages made of synthetic resin are also available. This type is most suitable for applications where low noise is required.

## Large load rating

Needle rollers are assembled in a cage with a small pitch distance, so load ratings are large.

## Easy handling

The rollers are retained in a cage securely, allowing easy handling and assembly.

## Adaptability to conventional plain guide ways

Single row and double row types are standardized and can be easily used to modify the conventional plain guide ways of machine tools, etc. into rolling guide type without large-scale redesign of the bed.

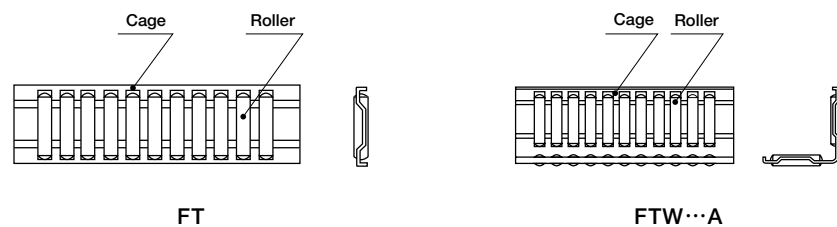

Structure of Flat Roller Cage

## Flat Roller Cage series

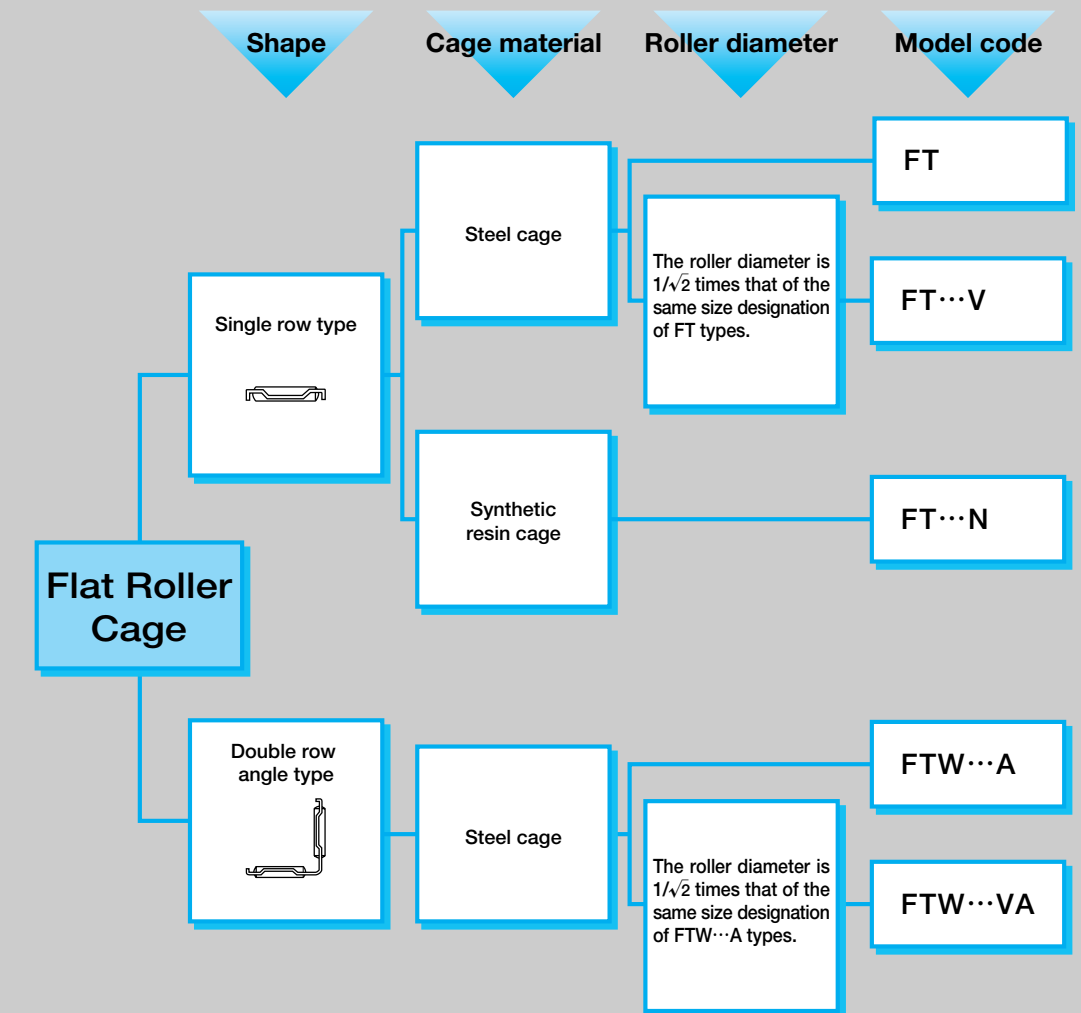

## ● Identification number and specification

The specification of Flat Roller Cage is indicated by the identification number, consisting of a model code, a size, any supplemental codes and a selection code.

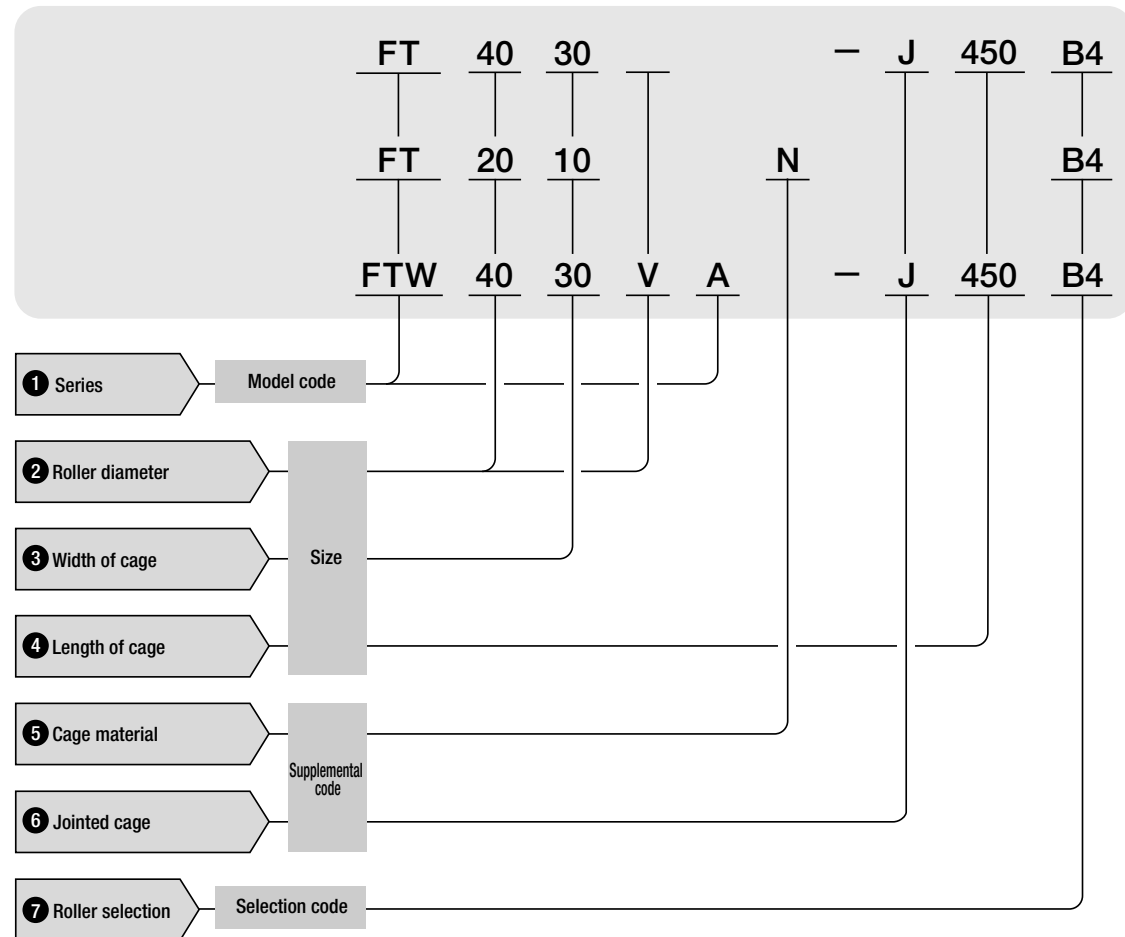

<b>1 Series</b>	Single row : FT Double rows : FTW...A
<b>2 Roller diameter</b>	Indicate a ten-fold numeric value of the roller diameter (mm). When symbol V is attached in the model code, indicate an integer obtained by multiplying the roller diameter(mm) by $10\sqrt{2}$ .
<b>3 Width of cage</b>	Indicate the width of cage in mm.

<b>4 Length of cage</b>	Indicate the length of cage in mm.	
<b>5 Cage material</b>	Steel cage : No symbol Synthetic resin cage : N	Specify the material of cage. For applicable models and sizes, see the "model number" column in the table of dimensions on page E-224. The maximum operating temperature for the synthetic resin type is 100°C. Continuous operation is possible at up to 80°C.
<b>6 Jointed cage</b>	Not jointed : No symbol Jointed : J	The overall length of the cage is also indicated. Specify this item when the standard length is exceeded.

Jointed Flat Roller Cages made from steel are available to extend the overall length of a cage. If the jointing specification is required, indicate "J" and the necessary overall length in millimeters in the identification number. Available maximum length of jointed Flat Roller Cage is shown in Table 1. If a longer Flat Roller Cage than the maximum length shown in Table 1 is required, consult **I<sup>K</sup>O**.

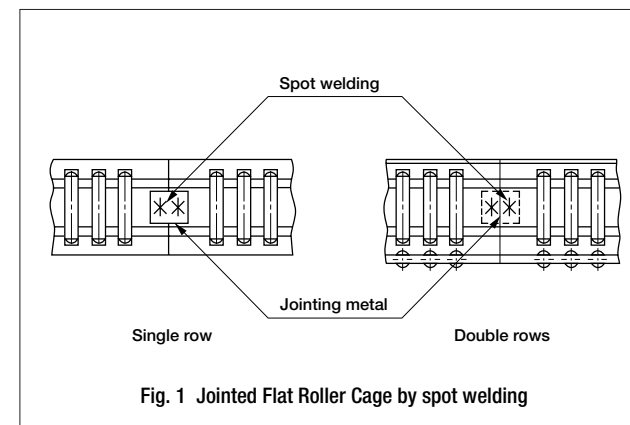

Fig. 1 Jointed Flat Roller Cage by spot welding

Table 1 Maximum length of jointed Flat Roller Cage  
unit : mm

Model number	Maximum length of jointed cage
FT 2010	
FT 2515	300
FT 3020	
FT 3525	375
FT 4030	
FT 4035	600
FT 4026 V	
FT 5038	
FT 5043	
FT 5030 V	1 000
FT 10080	
FT 10060 V	
FT 200120	1 500
FT 200100 V	1 000
FTW 4030 VA	600
FTW 5045 A	
FTW 5050 A	1 000
FTW 5035 VA	
FTW 10095 A	
FTW 10070 VA	1 500
FTW 200150 A	
FTW 200120 VA	

**7 Roller selection**

See Table 2.

Tolerances of the roller diameter of Flat Roller Cage are shown in Table 2. Any standard tolerance class rollers will be supplied unless otherwise specified. For a uniform load distribution, Flat Roller Cages with the same range of roller tolerance (the same selection code) are recommended for assembly. When the particular tolerance ranges are required, add its selection code onto the identification number.

**Table 2 Selection classification of rollers** unit :  $\mu\text{m}$

Selection classification	Selection code	Tolerance of mean diameter of rollers (1)
Standard	B2	0 ~ -2
	B4	-2 ~ -4
	B6	-4 ~ -6
	B8	-6 ~ -8
Semi-standard	A1	0 ~ -1
	A2	-1 ~ -2
	A3	-2 ~ -3
	A4	-3 ~ -4
	A5	-4 ~ -5
	A6	-5 ~ -6

Note(1) : The out of roundness and cylindricity conform to JIS B 1506 "Rollers for Roller Bearings".

**Load Rating**

The load ratings of Flat Roller Cage are defined for downward load. Summarized descriptions of load ratings are given below. For details of load rating definitions and load calculations, see "General description".

**Basic dynamic load rating  $C$**

The basic dynamic load rating is defined as the constant load both in direction and magnitude under which a group of identical Flat Roller Cages are individually operated and 90% of the units in the group can travel  $100 \times 10^3$  meters free from material damage due to rolling contact fatigue.

**Basic static load rating  $C_0$**

The basic static load rating is defined as the static load that gives a prescribed constant contact stress at the center of the contact area between the rolling element and raceway receiving the maximum load.

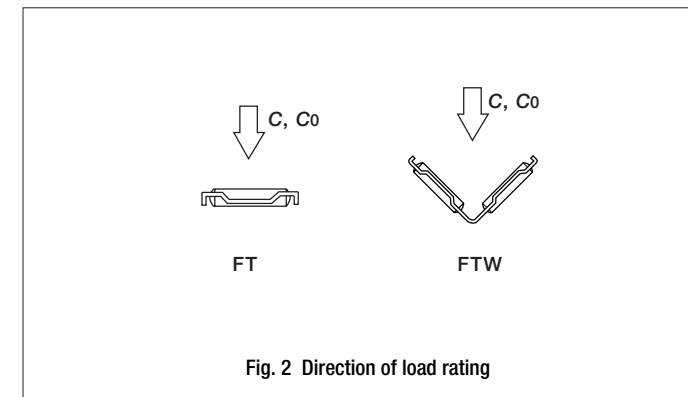

# Precautions for Use

## ① Mating raceways

Recommended surface hardness and roughness of mating raceways are shown in Table 3, and also recommended minimum effective hardening depth of the raceways is shown in Table 4.

**Table 3 Surface hardness and roughness of mating raceways**

Item	Recommended value	Remark
Surface hardness	58~64HRC	When the raceway hardness is less than the necessary hardness, multiply load ratings by the hardness factor.
Surface roughness	0.2 μmRa or better (0.8 μmRy or better)	When the required accuracy is not severe, a surface roughness of about 0.8 μmRa (3.2 μmRy) is adequate.

**Table 4 Minimum effective hardening depth** unit : mm

Roller diameter		Recommended minimum effective hardening depth
over	incl.	
—	3	0.5
3	4	0.8
4	5	1.0
5	8	1.5
8	10	2.0
10	14.142	2.5
14.142	20	3.5

## ② For V-Flat configuration where the flat and the 90° angle surfaces are present

Either FT and FTW...VA types or FT...V and FTW...A types are assembled after accurately lapping the raceways of bed and table on each other as shown in Fig. 3. The combinations of Flat Roller Cages are shown in Table 5.

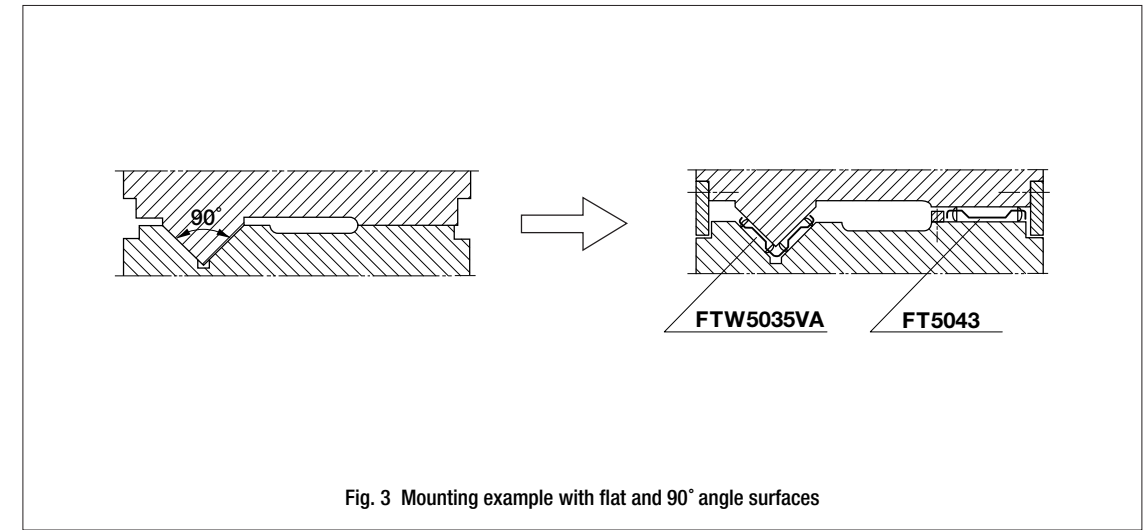

Fig. 3 Mounting example with flat and 90° angle surfaces

**Table 5 Combination of Flat Roller Cages** unit : mm

Combination number	For flat surface		For 90° angle surface	
	Model number	Roller diameter $D_w$	Model number	Roller diameter $D_w$
1	FT 4030	4	FTW 4030 VA	2.828
2	FT 4035	4	FTW 4030 VA	2.828
3	FT 5038	5	FTW 5035 VA	3.535
4	FT 5043	5	FTW 5035 VA	3.535
5	FT 10060 V	7.071	FTW 5045 A	5
6	FT 10060 V	7.071	FTW 5050 A	5
7	FT 10080	10	FTW 10070 VA	7.071
8	FT 200100 V	14.142	FTW 10095 A	10
9	FT 200120	20	FTW 200120 VA	14.142

**③ Stroke length and cage length**

When the table or bed is stroked in linear direction, Flat Roller Cage moves 1/2 distance of the stroke length of the table or bed in the same direction as shown in Fig.4. Therefore, the relationship among the raceway length, the stroke length and the cage length is given as in the following formula.

$$L_1 = \frac{S}{2} + L \dots\dots\dots(1)$$

where,  $L_1$ : Raceway length, mm  
 $S$ : Stroke length, mm  
 $L$ : Cage length, mm

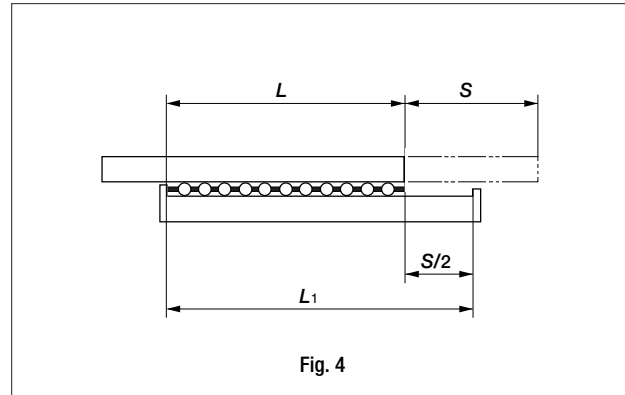

**Precautions for Mounting**

Flat Roller Cages are generally mounted as shown in Fig. 5. When mounting separate raceways, which are heat-treated and ground, onto the table and bed (See mounting examples 2 and 3 in Fig.5.), be careful not to cause deformation on the raceways by over tightening mounting bolts.

**① General mounting**

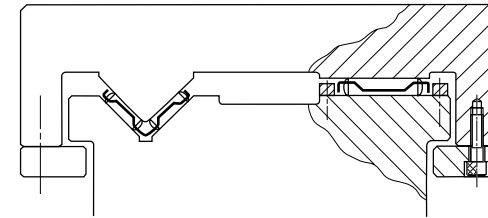

**② With separate raceways**

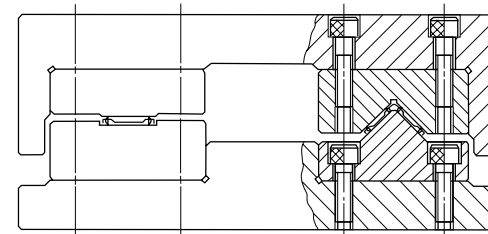

**③ When overhung load is applied**

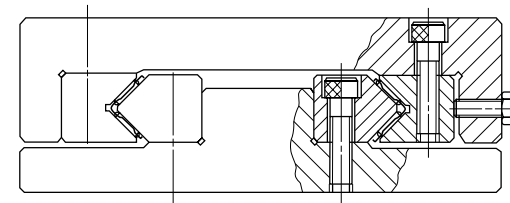
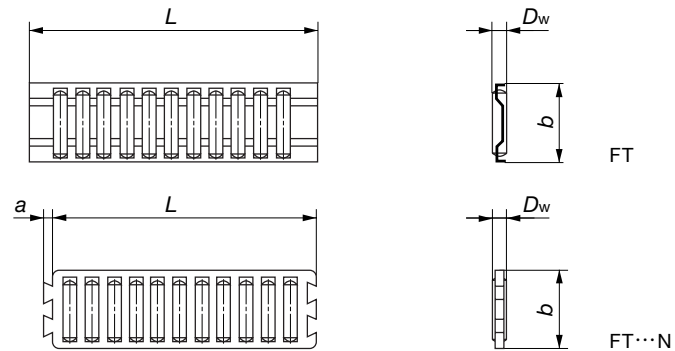

Fig. 5 Mounting examples

# IKO Flat Roller Cage

## Single row : FT



Model number		Mass (Ref.) g	Nominal dimensions mm				Basic dynamic load rating C N	Basic static load rating Co N
Steel cage	Synthetic resin cage		Dw	b	L	a		
—	<b>FT 2010N</b>	1.63	2	10	32	2	7 650	19 700
<b>FT 2010 - 32</b>	—	1.91	2	10	32	—	8 560	22 800
<b>FT 2010 - 100</b>	—	5.8	2	10	100	—	19 500	68 300
—	<b>FT 2515N</b>	4.3	2.5	15	45	2.5	15 100	40 900
<b>FT 2515 - 45</b>	—	5.6	2.5	15	45	—	19 200	55 900
<b>FT 2515 - 100</b>	—	11.6	2.5	15	100	—	32 300	112 000
—	<b>FT 3020N</b>	9.7	3	20	60	3	27 400	78 300
<b>FT 3020 - 60</b>	—	12.5	3	20	60	—	32 200	96 100
—	<b>FT 3525N</b>	18.6	3.5	25	75	3.5	44 300	131 000
<b>FT 3525 - 75</b>	—	23	3.5	25	75	—	50 300	155 000
<b>FT 4030 - 150</b>	—	73	4	30	150	—	107 000	380 000
<b>FT 4035 - 150</b>	—	86	4	35	150	—	120 000	443 000
<b>FT 4026V - 150</b>	—	45	2.828	26	150	—	81 900	345 000
<b>FT 5038 - 250</b>	—	195	5	38	250	—	221 000	846 000
<b>FT 5043 - 250</b>	—	200	5	43	250	—	254 000	1 010 000
<b>FT 5030V - 250</b>	—	103	3.535	30	250	—	149 000	649 000
<b>FT 10080 - 500</b>	—	1 610	10	80	500	—	1 130 000	4 340 000
<b>FT 10060V - 500</b>	—	870	7.071	60	500	—	681 000	2 890 000
<b>FT 200120 - 500</b>	—	4 940	20	120	500	—	2 540 000	7 620 000
<b>FT 200100V - 500</b>	—	2 860	14.142	100	500	—	1 700 000	5 780 000

# IKO Flat Roller Cage



## Double row : FTW...A

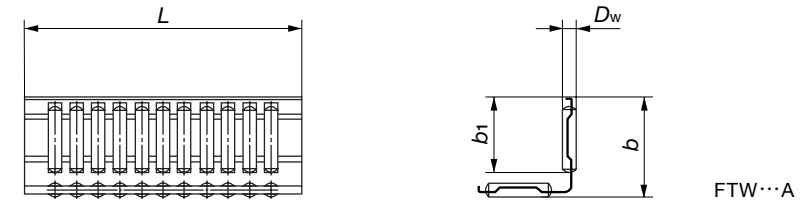

Model number		Mass (Ref.) g	Nominal dimensions mm				Basic dynamic load rating C N	Basic static load rating Co N
Steel cage	Synthetic resin cage		Dw	b	L	b1		
<b>FTW 4030VA - 150</b>	—	94	2.828	30	150	24.5	107 000	488 000
<b>FTW 5045A - 250</b>	—	410	5	45	250	35.5	297 000	1 230 000
<b>FTW 5050A - 250</b>	—	460	5	50	250	40.5	333 000	1 430 000
<b>FTW 5035VA - 250</b>	—	220	3.535	35	250	29	195 000	917 000
<b>FTW 10095A - 500</b>	—	3 360	10	95	500	77	1 480 000	6 140 000
<b>FTW 10070VA - 500</b>	—	1 790	7.071	70	500	56.5	892 000	4 080 000
<b>FTW 200150A - 500</b>	—	10 200	20	150	500	118	3 330 000	10 800 000
<b>FTW 200120VA - 500</b>	—	5 940	14.142	120	500	96	2 230 000	8 170 000



## ***Application Examples and Miscellaneous Tables***

---

Application Examples .....	F-2
Miscellaneous Tables .....	F-26
CAD Data .....	F-40



Horizontal machining center

LRX • LRXDG

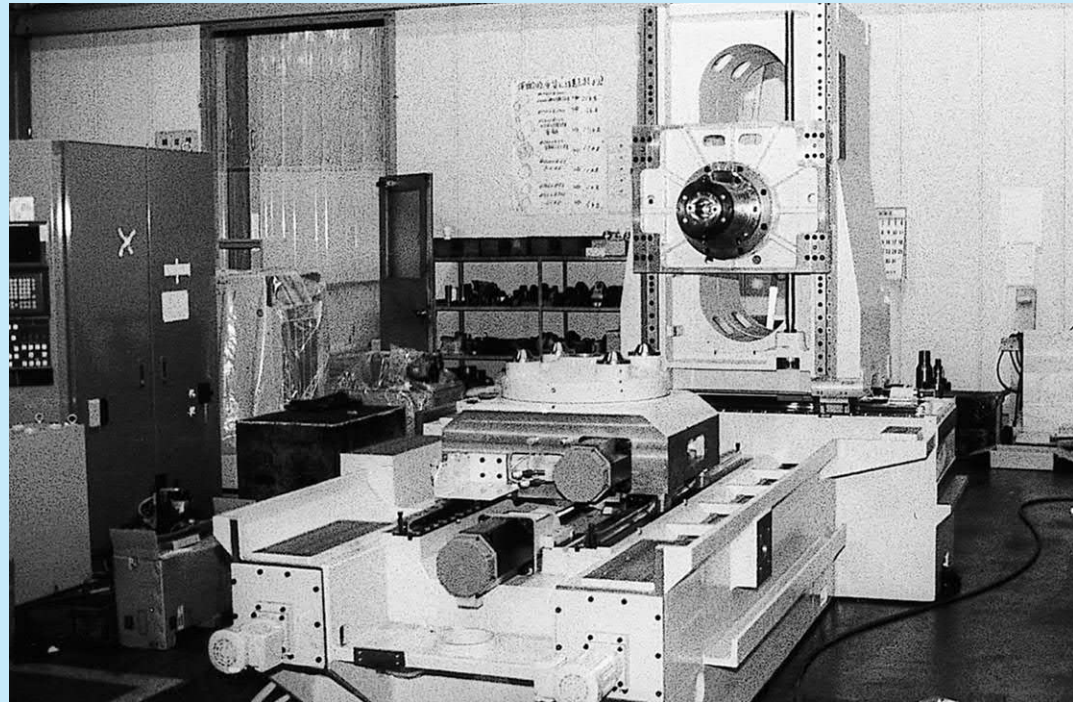
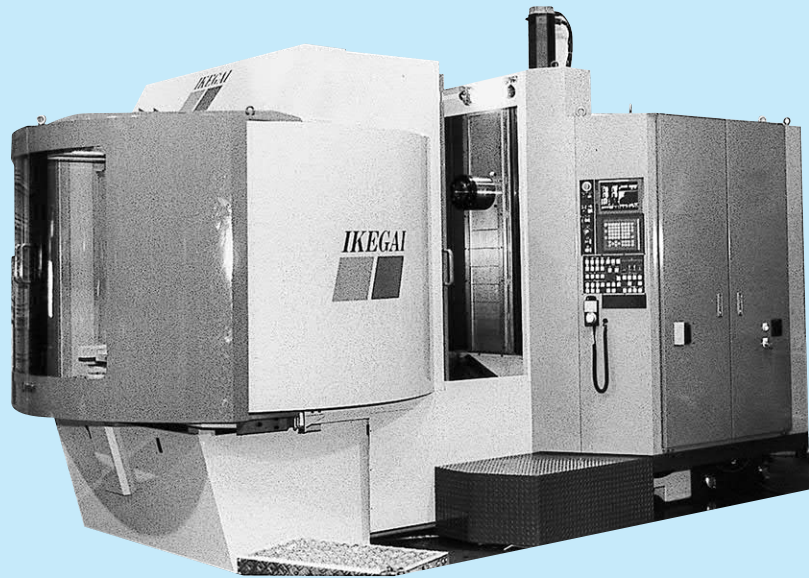

Vertical machining center

LWEC • LWE

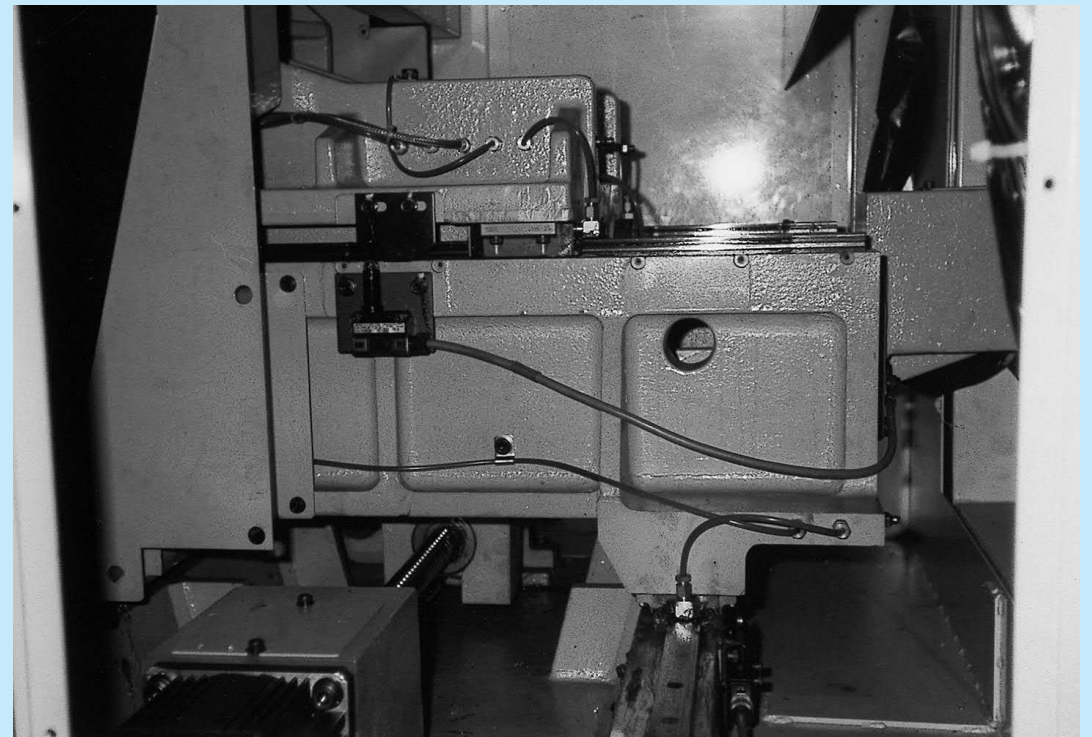

Gantry type machining center

LRXG

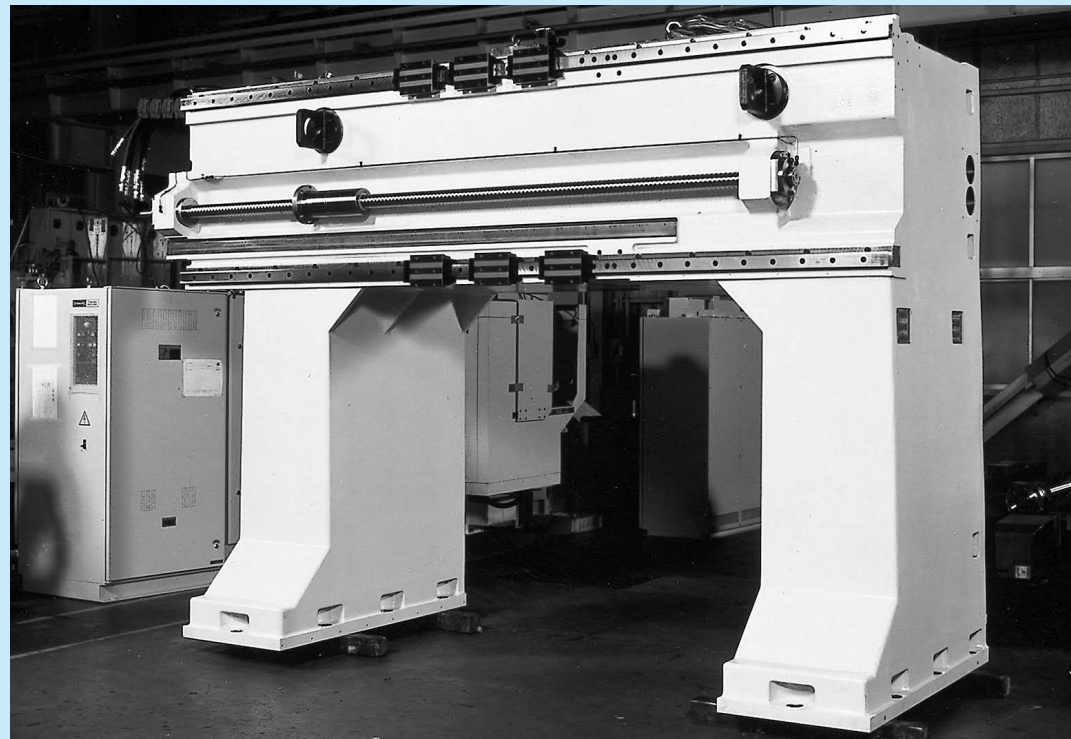
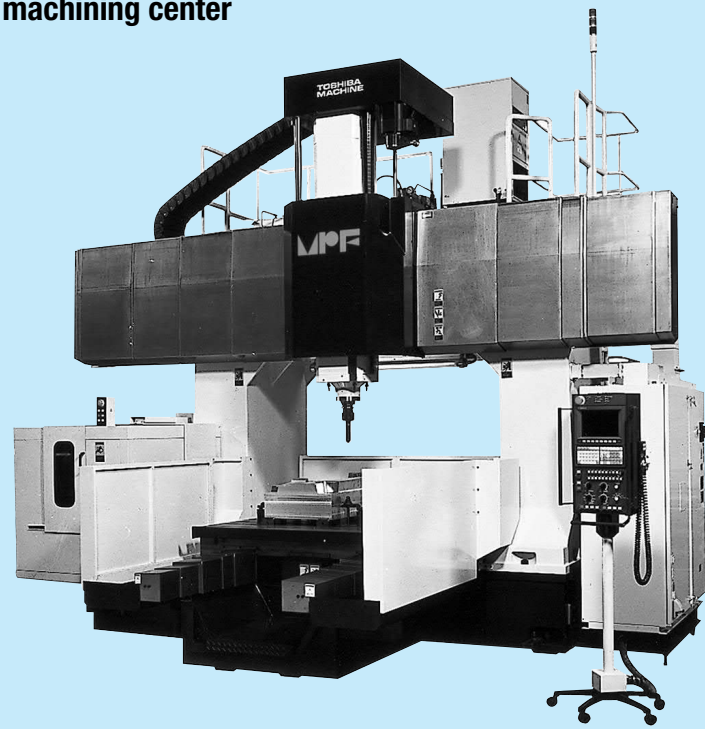

Gantry type machining center

LRWX • LWHG

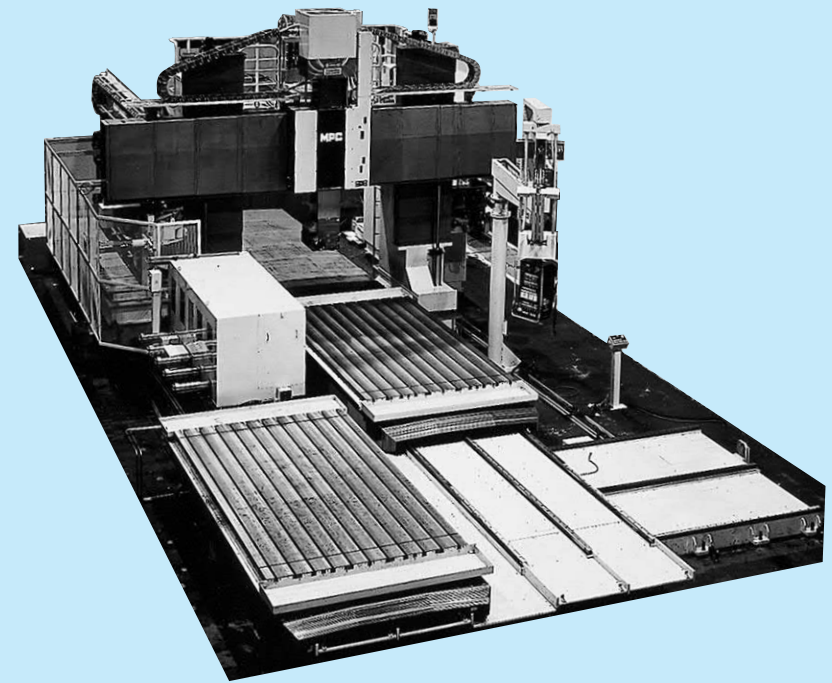

Four-axis control CNC lathe

LRX

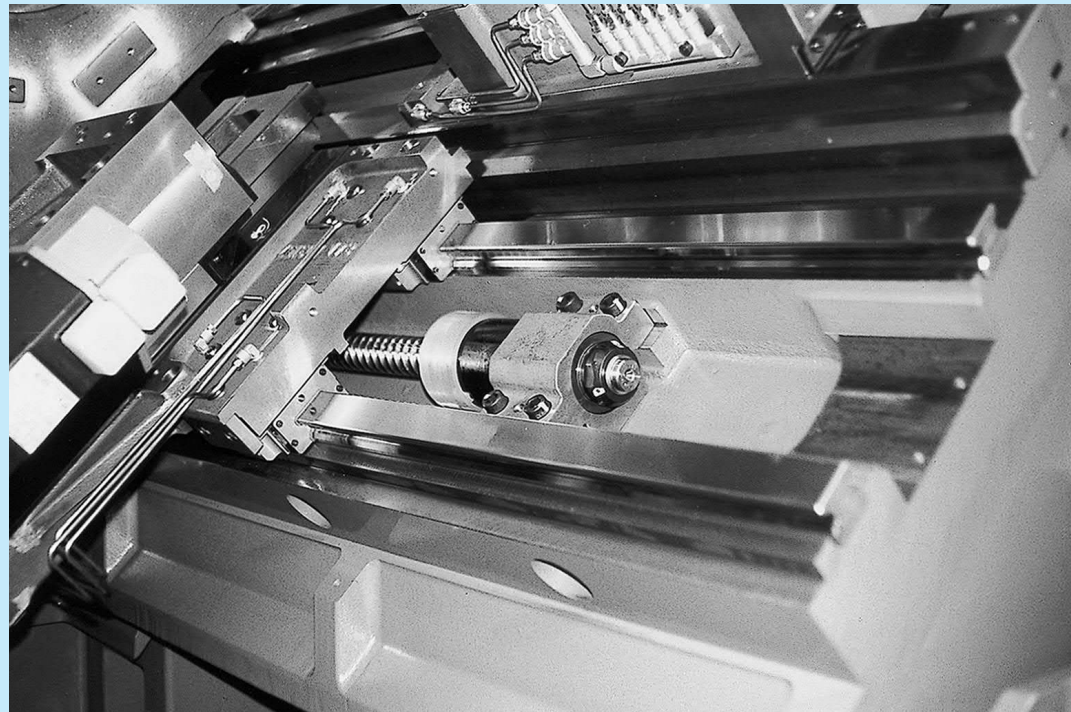
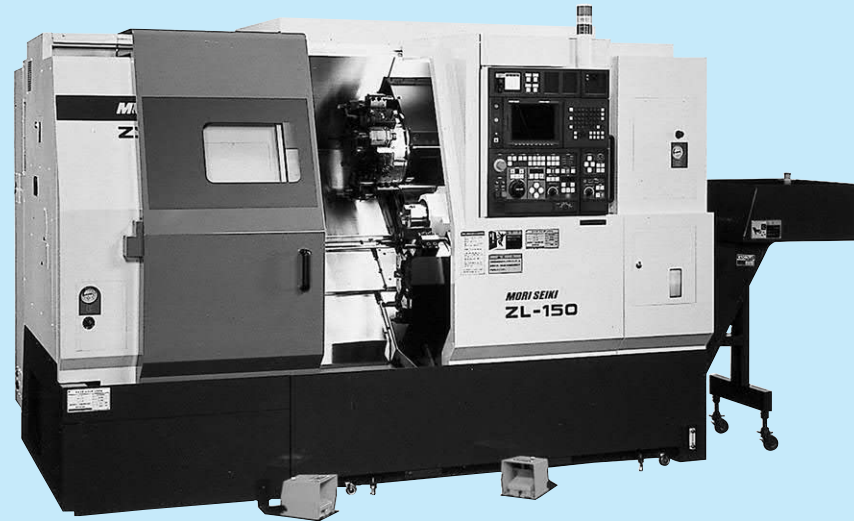

Surface grinding machine

LRX

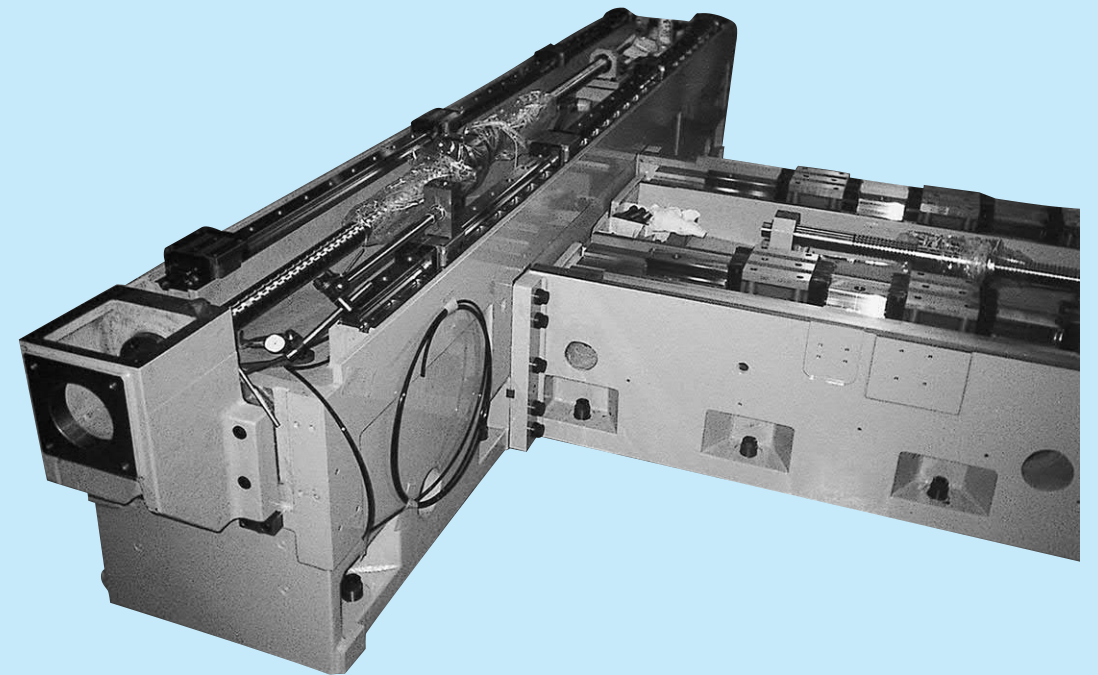
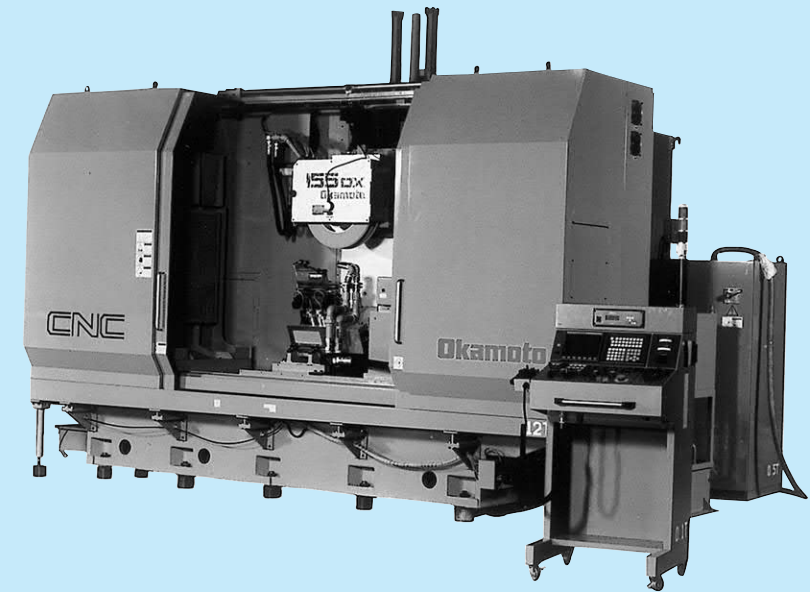

Synchronous control gear grinding machine

LRXG · LRWX

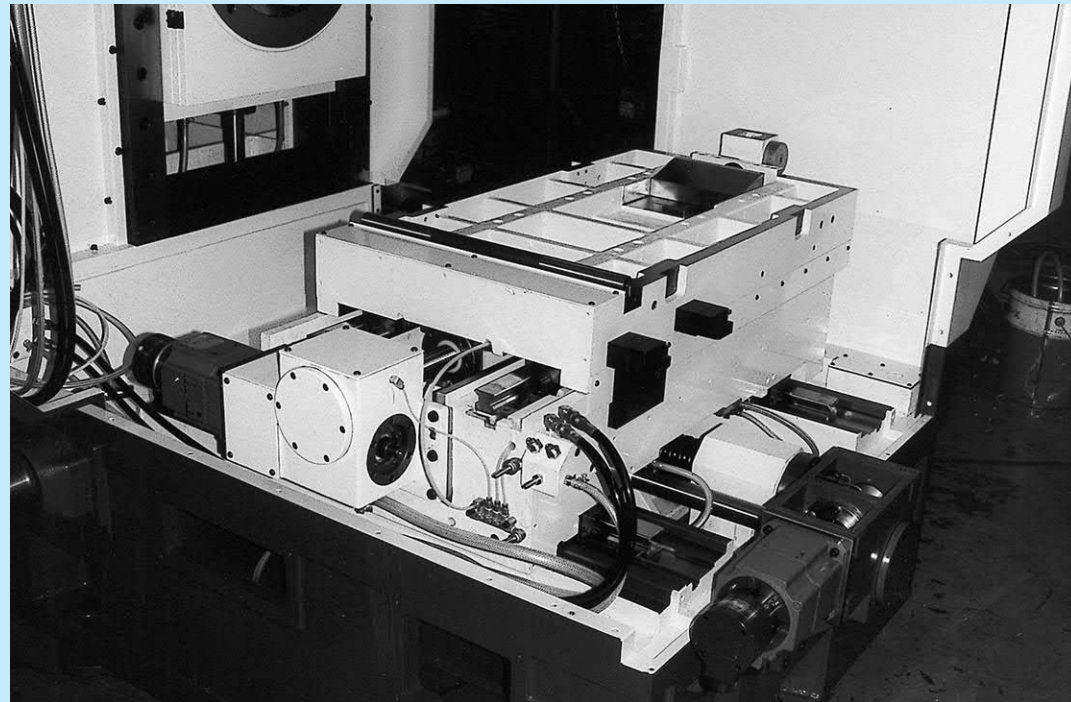
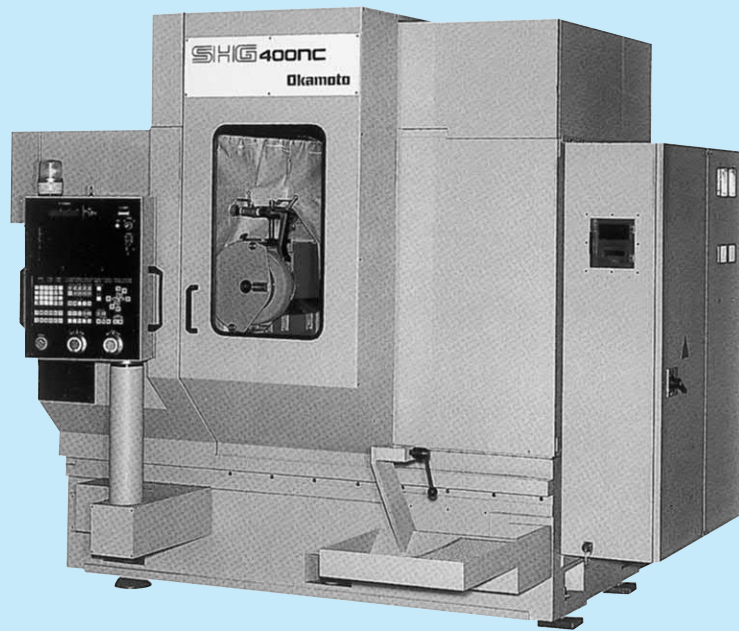

Tool grinding machine

LRXD · LRXDG

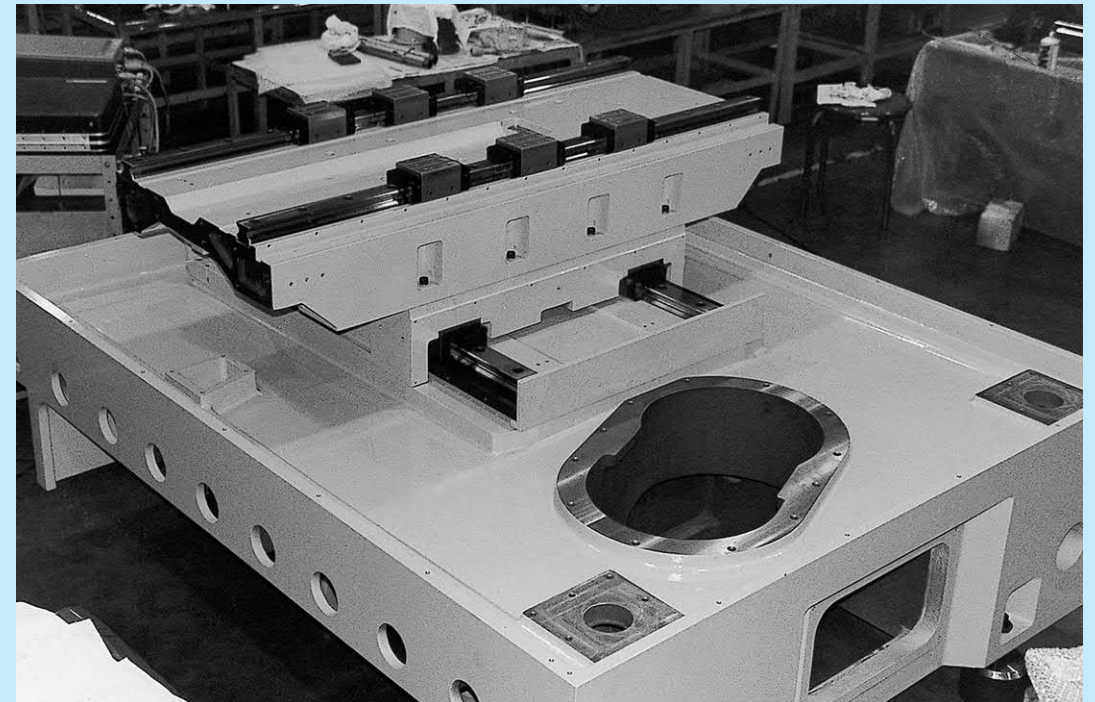
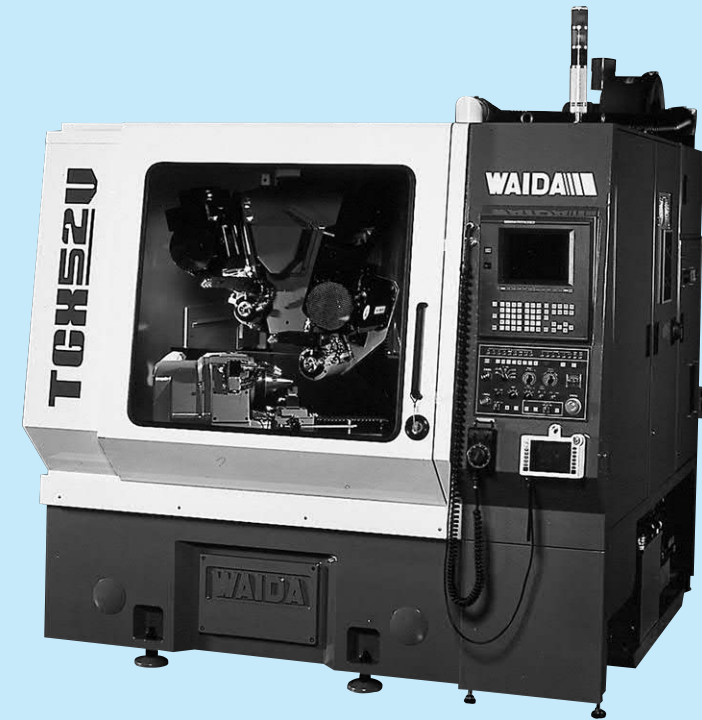

High-speed chip mounter

LWLF • LWHS • LWHSG • LSAG

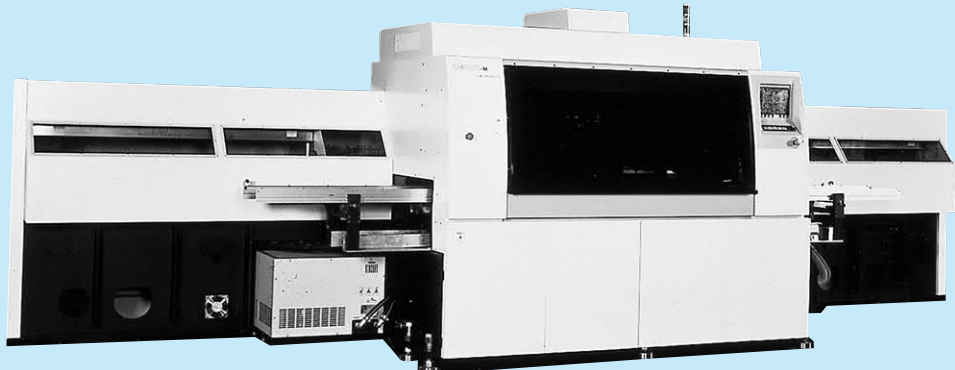

Chip mounter

LWLC • LSAGLT

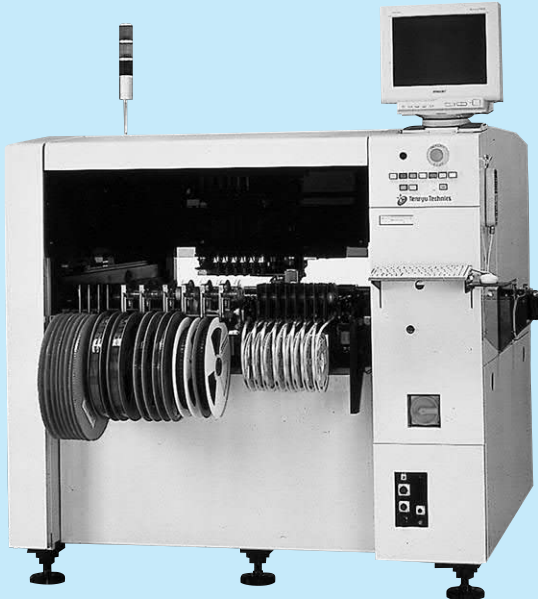

Surface mount system

LWL • LSAGT • BSR



Stepper

LWL • LWLF • LWLM • LWHS • STSI



Injection molding machine

LWES



Hollow molding machine

LRXC • LRX

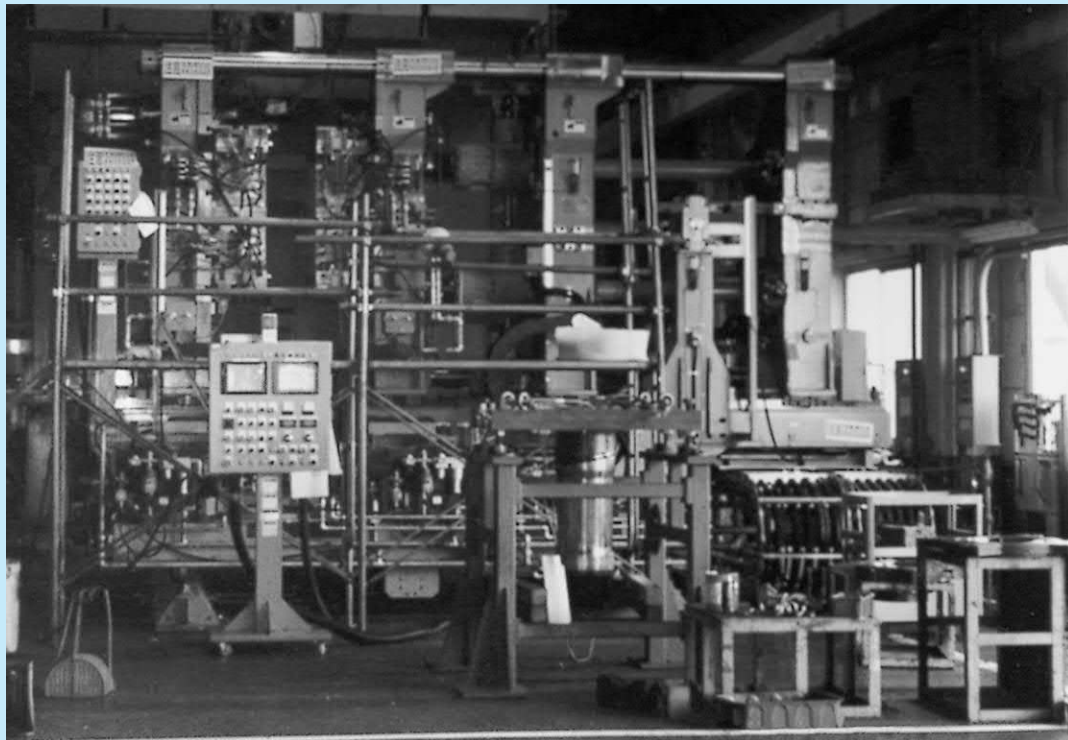

Web offset printing press

LWH • LWHDG



Multi-head type electronic embroidering machine

LWL



Circular saw

LSAG • LSAGF

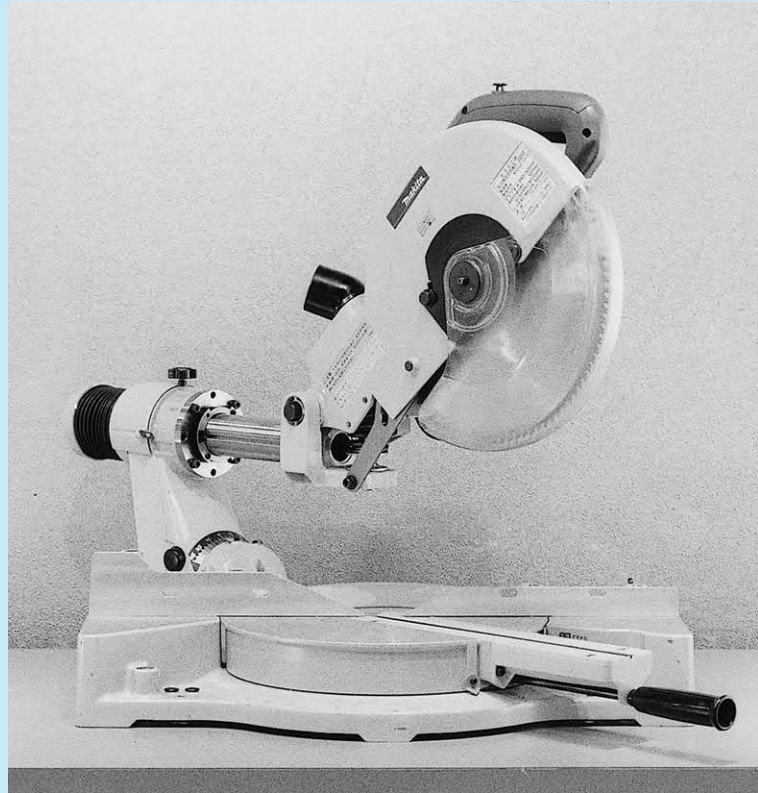

Spring forming machine

LWH • LWHS • CRW • CF • CRBH

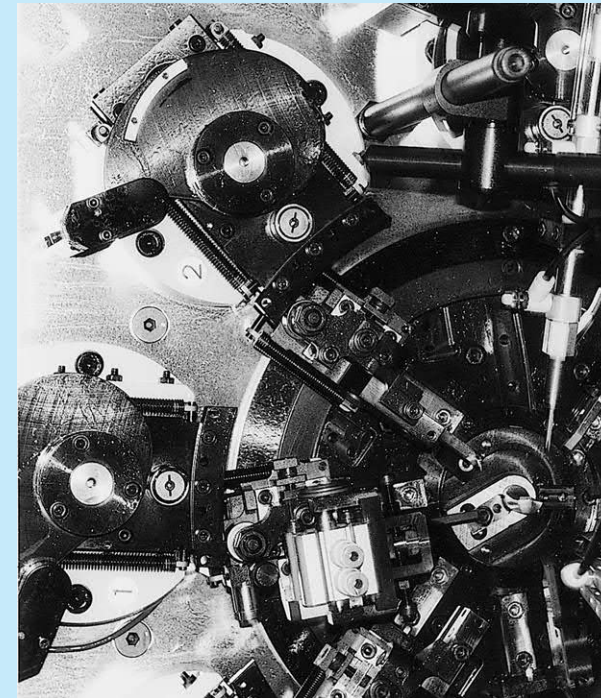

**Bundling machine**

**LWHS**

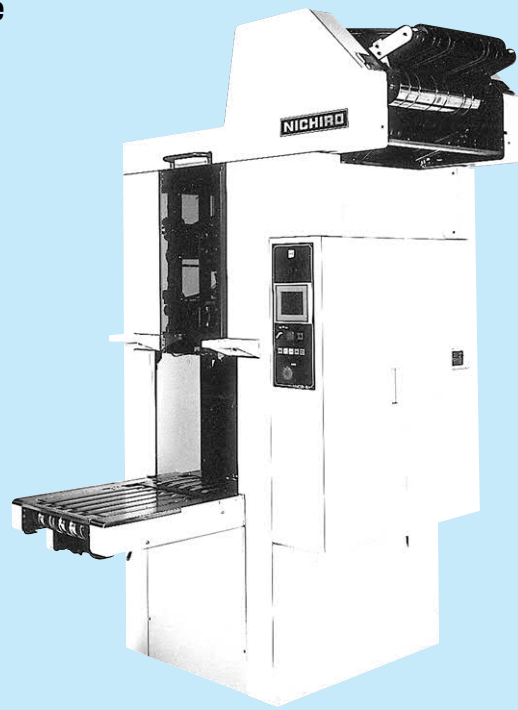

**Automatic case packer**

**LWL • LWES • LWH • LWHS • LWHDG**

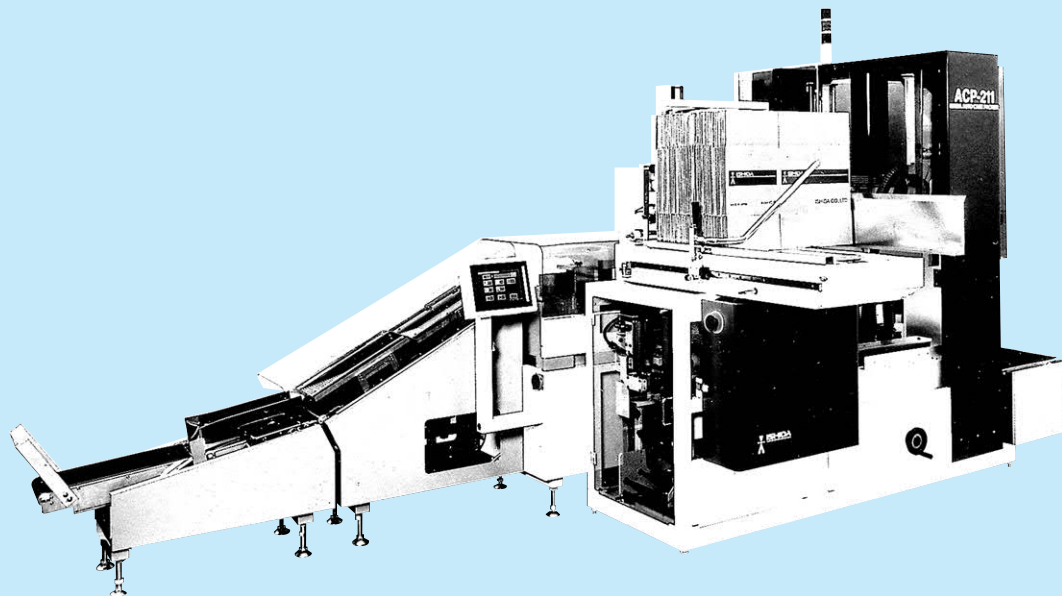

**High-pressure high-density lumber compression system**

**LRXG**

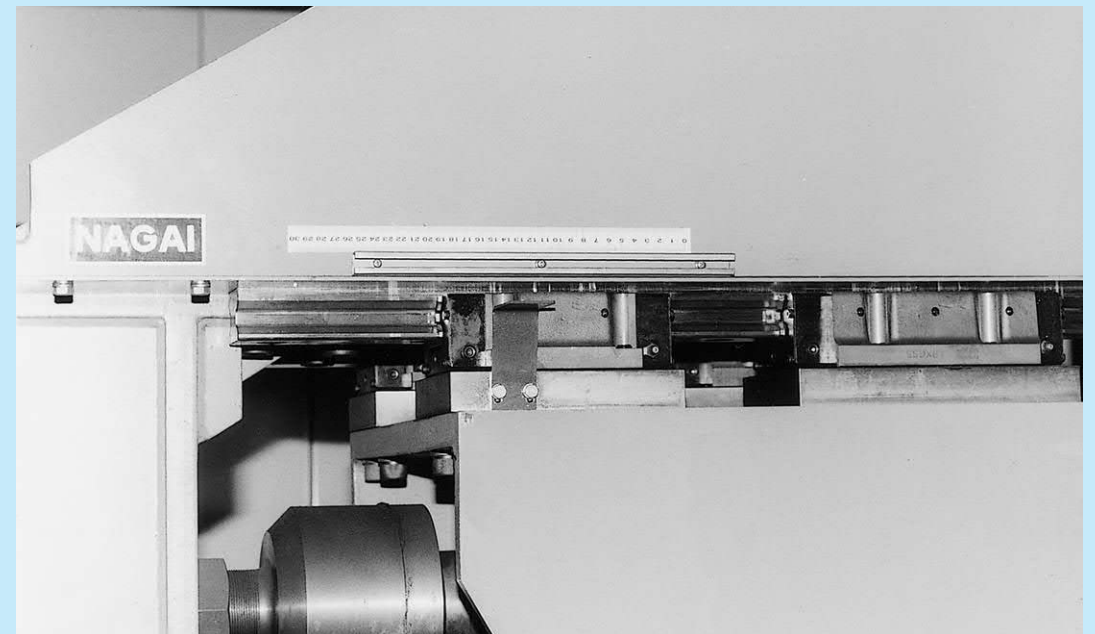



Stone polishing machine for curved surface

LWHD • LWH

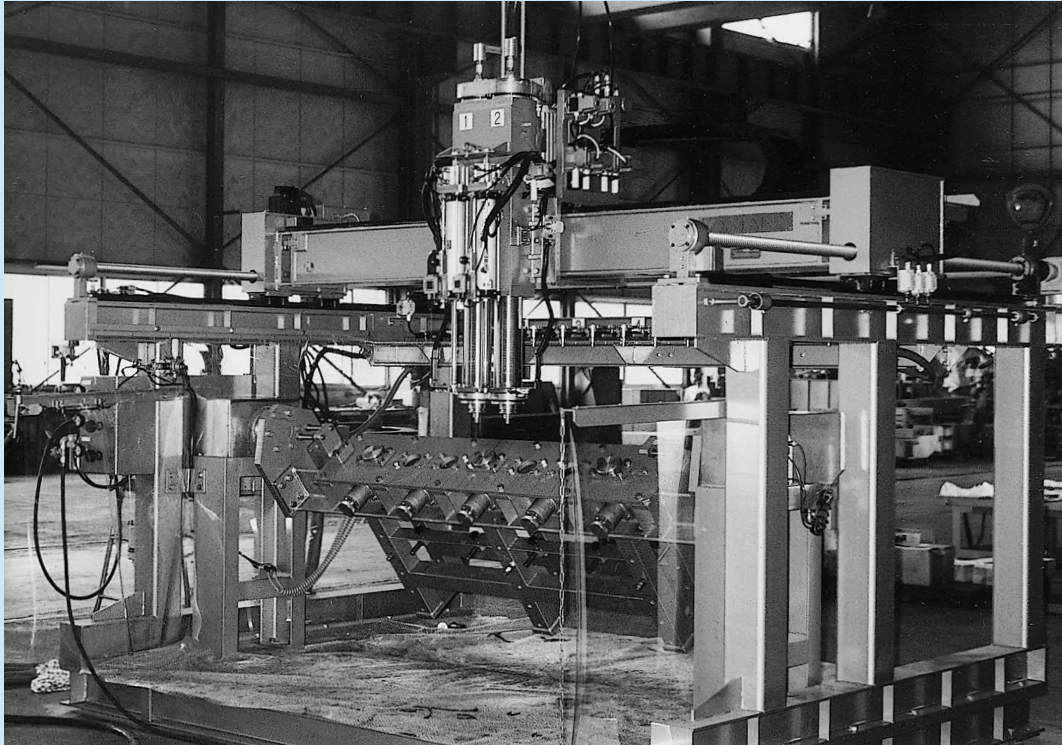

Shield type tunnel excavator

LRWX

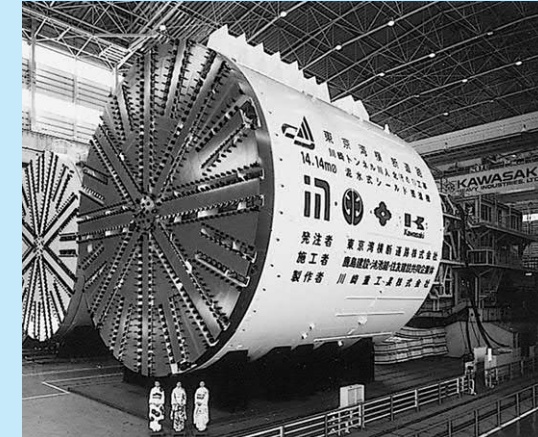

LRXDG • LWHS

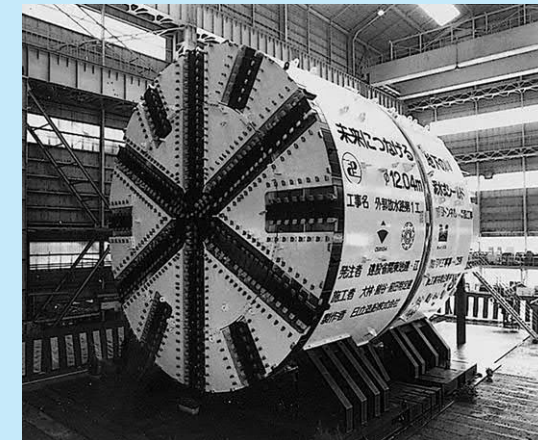

LRWX

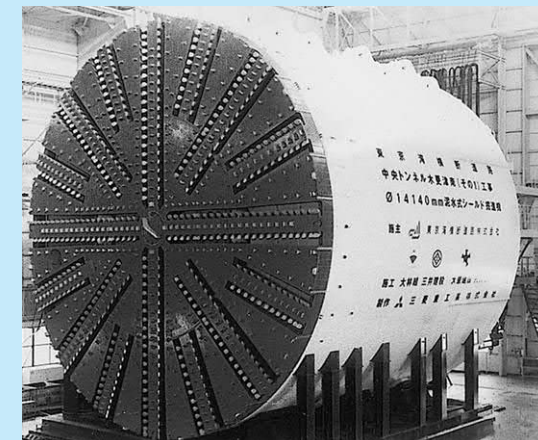

XYZ axis robot

LRW • LWHS



XYZ axis robot

LWHD

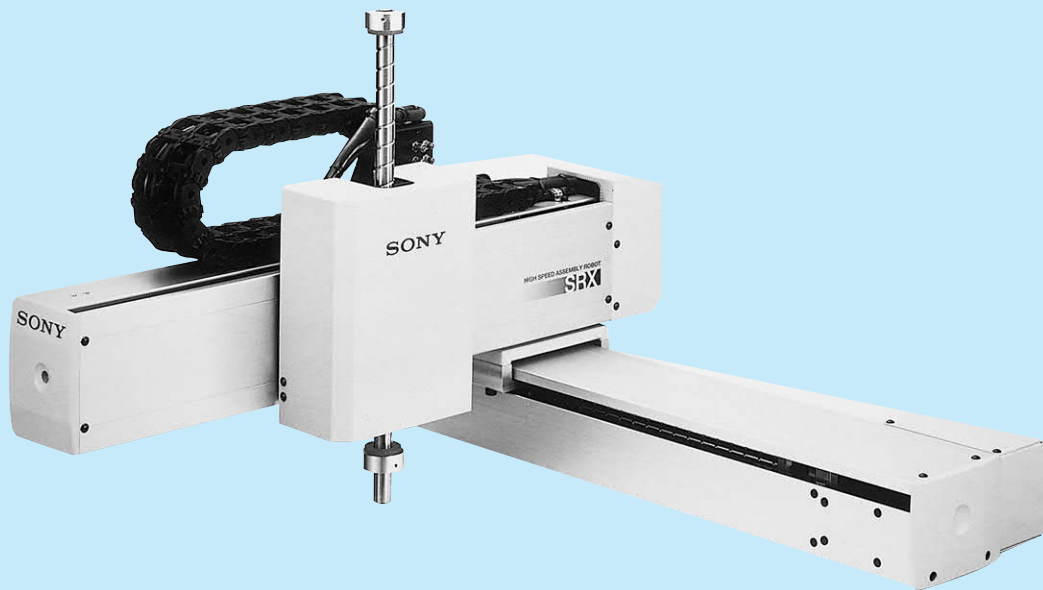

Scalar robot

CRBS



Scalar robot

LSAG • CRBH



Pneumatic actuator

LWL



Pick and place unit

LWLF • LWHS • LSA • CFS



Pneumatic slide table

LWL

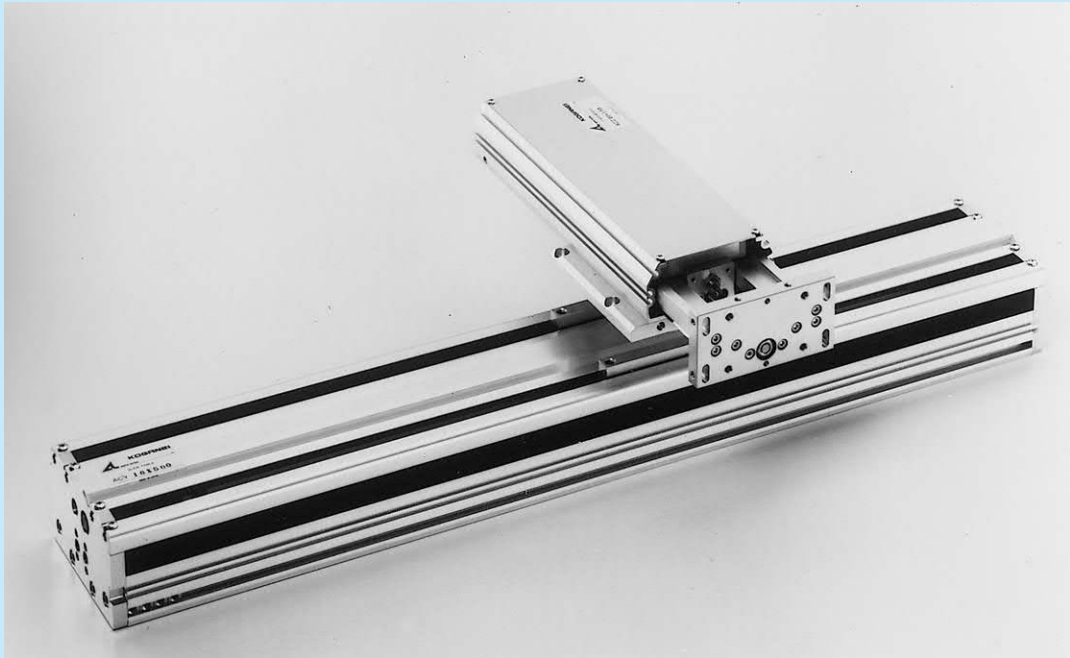

Rodless cylinder

LWL

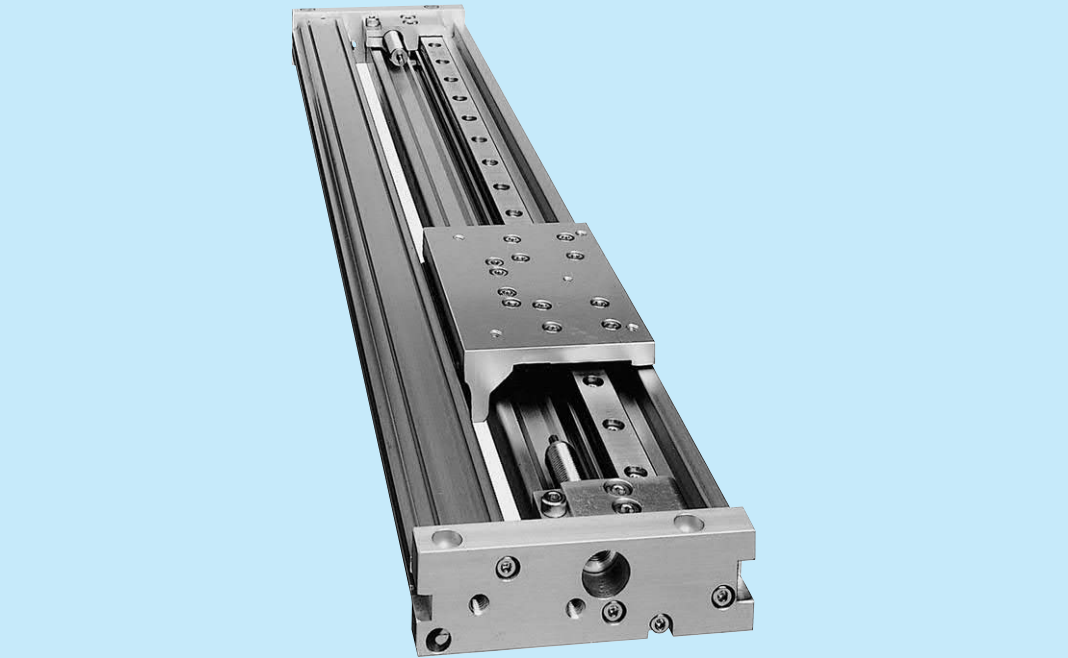

Multi-item auto hemocytometer

LWL

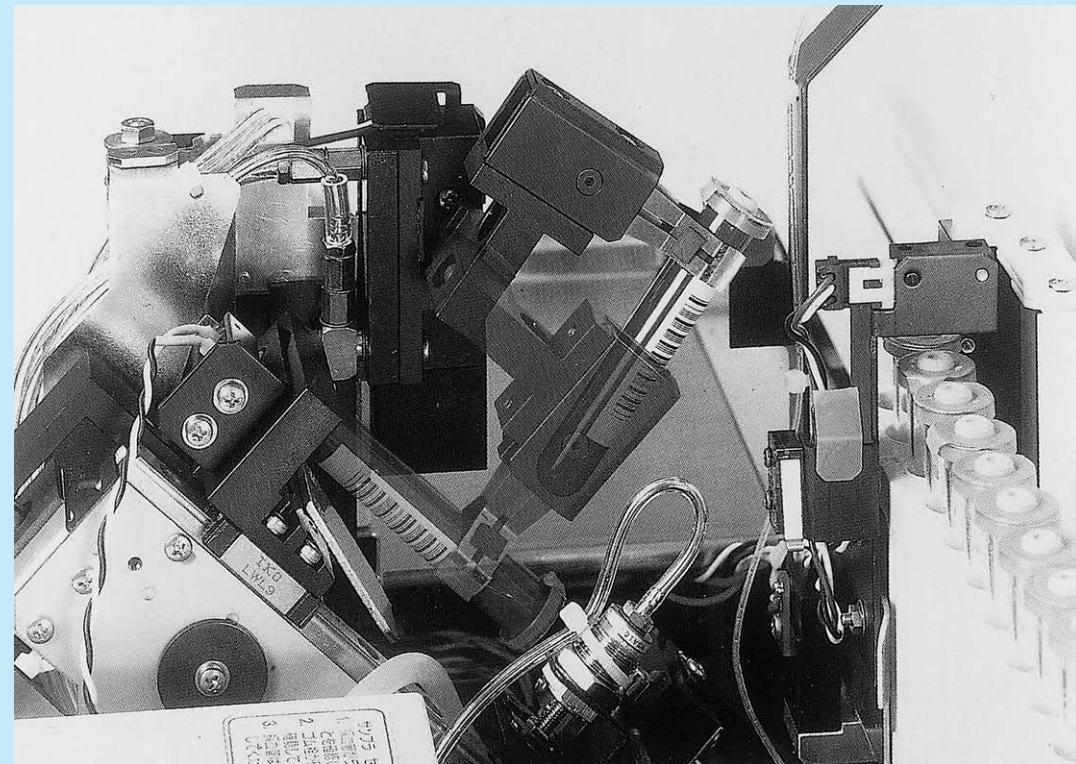

Digital gauge

STSI



Linear gauge sensor

LSAG



# Miscellaneous Tables

## ● Conversion Table of Units

Comparison table between SI units (system of international units), CGS units and KMS units (gravitational system of units)

Quantity System of units	Length	Mass	Time	Acceleration	Force	Stress	Pressure
SI units	m	kg	s	m/s <sup>2</sup>	N	Pa	Pa
CGS units	cm	g	s	Gal	dyn	dyn/cm <sup>2</sup>	dyn/cm <sup>2</sup>
KMS units	m	kgf·s <sup>2</sup> /m	s	m/s <sup>2</sup>	kgf	kgf/m <sup>2</sup>	kgf/m <sup>2</sup>

### Conversion into SI units

Quantity	Unit name	Symbol	Conversion factor into SI	SI unit name	Symbol
Angle	Degree	°	$\pi / 180$	Radian	rad
	Minute	'	$\pi / 10\ 800$		
	Second	"	$\pi / 648\ 000$		
Length	Meter	m	1	Meter	m
	Micrometer	$\mu$	$10^{-6}$		
	Angstrom	Å	$10^{-10}$		
	X-ray unit		$\approx 1.002\ 08 \times 10^{-13}$		
	Nautical mile	n mile	1852		
Area	Square meter	m <sup>2</sup>	1	Square meter	m <sup>2</sup>
	Are	a	$10^2$		
	Hectare	ha	$10^4$		
Volume	Cubic meter	m <sup>3</sup>	1	Cubic meter	m <sup>3</sup>
	Liter	l, L	$10^{-3}$		
Mass	Kilogram	kg	1	Kilogram	kg
	Ton	t	$10^3$		
	Atomic mass unit	u	$\approx 1.660\ 57 \times 10^{-27}$		
Time	Second	s	1	Second	s
	Minute	min	60		
	Hour	h	3 600		
	Day	d	86 400		
Velocity	Meter per second	m/s	1	Meter per second	m/s
	Knot	kn	$1\ 852/3\ 600$		
Frequency and number of oscillations per time	Cycle	s <sup>-1</sup>	1	Hertz	Hz
Rotation speed	Rotation per minute	rpm	1/60	Per second	s <sup>-1</sup>
Angular velocity	Radian per second	rad/s	1	Radian per second	rad/s
Acceleration	Meter per square second	m/s <sup>2</sup>	1	Meter per square second	m/s <sup>2</sup>
	G	G	9.806 65		
Force	Kilogram force	kgf	9.806 65	Newton	N
	Ton force	tf	9 806.65		
	Dyne	dyn	$10^{-5}$		
Moment of force	Kilogram force-meter	kgf·m	9.806 65	Newton-meter	N·m
Stress and pressure	Kilogram force per square meter	kgf/m <sup>2</sup>	9.806 65	Pascal	Pa
	Kilogram force per square centimeter	kgf/cm <sup>2</sup>	$9.806\ 65 \times 10^4$		
	Kilogram force per square millimeter	kgf/mm <sup>2</sup>	$9.806\ 65 \times 10^6$		

Energy	Power	Temperature	Viscosity	Kinematic viscosity	Magnetic flux	Magnetic flux density	Magnetic field intensity
J	W	K	Pa·s	m <sup>2</sup> /s	Wb	T	A/m
erg	erg/s	°C	P	St	Mx	Gs	Oe
kgf·m	kgf·m/s	°C	kgf·s/m <sup>2</sup>	m <sup>2</sup> /s	—	—	—

Quantity	Unit name	Symbol	Conversion factor into SI	SI unit name	Symbol
Pressure	Hydro-column meter	mH <sub>2</sub> O	9 806.65	Pascal	Pa
	Mercurial column millimeter	mmHg	$101\ 325/760$		
	Torr	Torr	$101\ 325/760$		
	Atmosphere	atm	101 325		
	Bar	bar	$10^5$		
Energy	Erg	erg	$10^{-7}$	Joule	J
	IT calorie	cal <sub>IT</sub>	4.186 8		
	Kilogram force - meter	kgf·m	9.806 65		
	Kilowatt hour	kW·h	$3.600 \times 10^6$		
	Horse power hour (French)	PS·h	$\approx 2.647\ 79 \times 10^6$		
	Electron volt	eV	$\approx 1.602\ 19 \times 10^{-19}$		
Power	Watt	W	1	Watt	W
	Horse power (French)	PS	$\approx 735.5$		
	Kilogram force -meter per second	kgf·m/s	9.806 65		
Viscosity	Poise	P	$10^{-1}$	Pascal-second	Pa·s
	Centipoise	cP	$10^{-3}$		
	Kilogram force-second per square meter	kgf·s/m <sup>2</sup>	9.806 65		
Kinematic viscosity	Stokes	St	$10^{-4}$	Square meter per second	m <sup>2</sup> /s
	Centistokes	cSt	$10^{-6}$		
Temperature	Degree	°C	+273.15	Kelvin	K
Radioactivity	Curie	Ci	$3.7 \times 10^{10}$	Becquerel	Bq
	Exposure dose	R	$2.58 \times 10^{-4}$		
	Absorbed dose	rad	$10^{-2}$		
	Dose equivalent	rem	$10^{-2}$		
Magnetic flux	Maxwell	Mx	$10^{-8}$	Weber	Wb
Magnetic flux density	Gamma	$\gamma$	$10^{-9}$	Tesla	T
	Gauss	Gs	$10^{-4}$		
Magnetic field intensity	Oersted	Oe	$10^3/4\ \pi$	Ampere per meter	A/m
Quantity of electricity	Coulomb	C	1	Coulomb	C
	Volt	V	1		
Electric potential difference					
Electrostatic capacity	Farad	F	1	Farad	F
(Electric) resistance	Ohm	$\Omega$	1	Ohm	$\Omega$
(Electric) conductance	Siemens	S	1	Siemens	S
Inductance	Henry	H	1	Henry	H
Current	Ampere	A	1	Ampere	A

# Inch-mm Conversion Table

1 inch = 25.4 mm

inch		0"	1"	2"	3"	4"	5"	6"	7"	8"
Fraction	Decimal									
0	0		25.400	50.800	76.200	101.600	127.000	152.400	177.800	203.200
1 / 64"	0.015625	0.397	25.797	51.197	76.597	101.997	127.397	152.797	178.197	203.597
1 / 32"	0.031250	0.794	26.194	51.594	76.994	102.394	127.794	153.194	178.594	203.994
3 / 64"	0.046875	1.191	26.591	51.991	77.391	102.791	128.191	153.591	178.991	204.391
1 / 16"	0.062500	1.588	26.988	52.388	77.788	103.188	128.588	153.988	179.388	204.788
5 / 64"	0.078125	1.984	27.384	52.784	78.184	103.584	128.984	154.384	179.784	205.184
3 / 32"	0.093750	2.381	27.781	53.181	78.581	103.981	129.381	154.781	180.181	205.581
7 / 64"	0.109375	2.778	28.178	53.578	78.978	104.378	129.778	155.178	180.578	205.978
1 / 8"	0.125000	3.175	28.575	53.975	79.375	104.775	130.175	155.575	180.975	206.375
9 / 64"	0.140625	3.572	28.972	54.372	79.772	105.172	130.572	155.972	181.372	206.772
5 / 32"	0.156250	3.969	29.369	54.769	80.169	105.569	130.969	156.369	181.769	207.169
11 / 64"	0.171875	4.366	29.766	55.166	80.566	105.966	131.366	156.766	182.166	207.566
3 / 16"	0.187500	4.762	30.162	55.562	80.962	106.362	131.762	157.162	182.562	207.962
13 / 64"	0.203125	5.159	30.559	55.959	81.359	106.759	132.159	157.559	182.959	208.359
7 / 32"	0.218750	5.556	30.956	56.356	81.756	107.156	132.556	157.956	183.356	208.756
15 / 64"	0.234375	5.953	31.353	56.753	82.153	107.553	132.953	158.353	183.753	209.153
1 / 4"	0.250000	6.350	31.750	57.150	82.550	107.950	133.350	158.750	184.150	209.550
17 / 64"	0.265625	6.747	32.147	57.547	82.947	108.347	133.747	159.147	184.547	209.947
9 / 32"	0.281250	7.144	32.544	57.944	83.344	108.744	134.144	159.544	184.944	210.344
19 / 64"	0.296875	7.541	32.941	58.341	83.741	109.141	134.541	159.941	185.341	210.741
5 / 16"	0.312500	7.938	33.338	58.738	84.138	109.538	134.938	160.338	185.738	211.138
21 / 64"	0.328125	8.334	33.734	59.134	84.534	109.934	135.334	160.734	186.134	211.534
11 / 32"	0.343750	8.731	34.131	59.531	84.931	110.331	135.731	161.131	186.531	211.931
23 / 64"	0.359375	9.128	34.528	59.928	85.328	110.728	136.128	161.528	186.928	212.328
3 / 8"	0.375000	9.525	34.925	60.325	85.725	111.125	136.525	161.925	187.325	212.725
25 / 64"	0.390625	9.922	35.322	60.722	86.122	111.522	136.922	162.322	187.722	213.122
13 / 32"	0.406250	10.319	35.719	61.119	86.519	111.919	137.319	162.719	188.119	213.519
27 / 64"	0.421875	10.716	36.116	61.516	86.916	112.316	137.716	163.116	188.516	213.916
7 / 16"	0.437500	11.112	36.512	61.912	87.312	112.712	138.112	163.512	188.912	214.312
29 / 64"	0.453125	11.509	36.909	62.309	87.709	113.109	138.509	163.909	189.309	214.709
15 / 32"	0.468750	11.906	37.306	62.706	88.106	113.506	138.906	164.306	189.706	215.106
31 / 64"	0.484375	12.303	37.703	63.103	88.503	113.903	139.303	164.703	190.103	215.503
1 / 2"	0.500000	12.700	38.100	63.500	88.900	114.300	139.700	165.100	190.500	215.900

1 inch = 25.4 mm

inch		0"	1"	2"	3"	4"	5"	6"	7"	8"
Fraction	Decimal									
33 / 64"	0.515625	13.097	38.497	63.897	89.297	114.697	140.097	165.497	190.897	216.297
17 / 32"	0.531250	13.494	38.894	64.294	89.694	115.094	140.494	165.894	191.294	216.694
35 / 64"	0.546875	13.891	39.291	64.691	90.091	115.491	140.891	166.291	191.691	217.091
9 / 16"	0.562500	14.288	39.688	65.088	90.488	115.888	141.288	166.688	192.088	217.488
37 / 64"	0.578125	14.684	40.084	65.484	90.884	116.284	141.684	167.084	192.484	217.884
19 / 32"	0.593750	15.081	40.481	65.881	91.281	116.681	142.081	167.481	192.881	218.281
39 / 64"	0.609375	15.478	40.878	66.278	91.678	117.078	142.478	167.878	193.278	218.678
5 / 8"	0.625000	15.875	41.275	66.675	92.075	117.475	142.875	168.275	193.675	219.075
41 / 64"	0.640625	16.272	41.672	67.072	92.472	117.872	143.272	168.672	194.072	219.472
21 / 32"	0.656250	16.669	42.069	67.469	92.869	118.269	143.669	169.069	194.469	219.869
43 / 64"	0.671875	17.066	42.466	67.866	93.266	118.666	144.066	169.466	194.866	220.266
11 / 16"	0.687500	17.462	42.862	68.262	93.662	119.062	144.462	169.862	195.262	220.662
45 / 64"	0.703125	17.859	43.259	68.659	94.059	119.459	144.859	170.259	195.659	221.059
23 / 32"	0.718750	18.256	43.656	69.056	94.456	119.856	145.256	170.656	196.056	221.456
47 / 64"	0.734375	18.653	44.053	69.453	94.853	120.253	145.653	171.053	196.453	221.853
3 / 4"	0.750000	19.050	44.450	69.850	95.250	120.650	146.050	171.450	196.850	222.250
49 / 64"	0.765625	19.447	44.847	70.247	95.647	121.047	146.447	171.847	197.247	222.647
25 / 32"	0.781250	19.844	45.244	70.644	96.044	121.444	146.844	172.244	197.644	223.044
51 / 64"	0.796875	20.241	45.641	71.041	96.441	121.841	147.241	172.641	198.041	223.441
13 / 16"	0.812500	20.638	46.038	71.438	96.838	122.238	147.638	173.038	198.438	223.838
53 / 64"	0.828125	21.034	46.434	71.834	97.234	122.634	148.034	173.434	198.834	224.234
27 / 32"	0.843750	21.431	46.831	72.231	97.631	123.031	148.431	173.831	199.231	224.631
55 / 64"	0.859375	21.828	47.228	72.628	98.028	123.428	148.828	174.228	199.628	225.028
7 / 8"	0.875000	22.225	47.625	73.025	98.425	123.825	149.225	174.625	200.025	225.425
57 / 64"	0.890625	22.622	48.022	73.422	98.822	124.222	149.622	175.022	200.422	225.822
29 / 32"	0.906250	23.019	48.419	73.819	99.219	124.619	150.019	175.419	200.819	226.219
59 / 64"	0.921875	23.416	48.816	74.216	99.616	125.016	150.416	175.816	201.216	226.616
15 / 16"	0.937500	23.812	49.212	74.612	100.012	125.412	150.812	176.212	201.612	227.012
61 / 64"	0.953125	24.209	49.609	75.009	100.409	125.809	151.209	176.609	202.009	227.409
31 / 32"	0.968750	24.606	50.006	75.406	100.806	126.206	151.606	177.006	202.406	227.806
63 / 64"	0.984375	25.003	50.403	75.803	101.203	126.603	152.003	177.403	202.803	228.203

## ● Hardness Conversion Table (Reference)

Rockwell C scale hardness Load 1471N	Vickers' hardness  HV	Brinell hardness		Rockwell hardness		Shore hardness  HS
		Standard ball	Tungsten carbide ball	A scale Load 588.4N Diamond circular cone	B scale Load 980.7N 1/16" ball	
68	940	—	—	85.6	—	97
67	900	—	—	85.0	—	95
66	865	—	—	84.5	—	92
65	832	—	(739)	83.9	—	91
64	800	—	(722)	83.4	—	88
63	772	—	(705)	82.8	—	87
62	746	—	(688)	82.3	—	85
61	720	—	(670)	81.8	—	83
60	697	—	(654)	81.2	—	81
59	674	—	(634)	80.7	—	80
58	653	—	615	80.1	—	78
57	633	—	595	79.6	—	76
56	613	—	577	79.0	—	75
55	595	—	560	78.5	—	74
54	577	—	543	78.0	—	72
53	560	—	525	77.4	—	71
52	544	(500)	512	76.8	—	69
51	528	(487)	496	76.3	—	68
50	513	(475)	481	75.9	—	67
49	498	(464)	469	75.2	—	66
48	484	451	455	74.7	—	64
47	471	442	443	74.1	—	63
46	458	432	432	73.6	—	62
45	446	421	421	73.1	—	60
44	434	409	409	72.5	—	58
43	423	400	400	72.0	—	57
42	412	390	390	71.5	—	56
41	402	381	381	70.9	—	55
40	392	371	371	70.4	—	54
39	382	362	362	69.9	—	52

Rockwell C scale hardness Load 1471N	Vickers' hardness  HV	Brinell hardness		Rockwell hardness		Shore hardness  HS
		Standard ball	Tungsten carbide ball	A scale Load 588.4N Diamond circular cone	B scale Load 980.7N 1/16" ball	
38	372	353	353	69.4	—	51
37	363	344	344	68.9	—	50
36	354	336	336	68.4	(109.0)	49
35	345	327	327	67.9	(108.5)	48
34	336	319	319	67.4	(108.0)	47
33	327	311	311	66.8	(107.5)	46
32	318	301	301	66.3	(107.0)	44
31	310	294	294	65.8	(106.0)	43
30	302	286	286	65.3	(105.5)	42
29	294	279	279	64.7	(104.5)	41
28	286	271	271	64.3	(104.0)	41
27	279	264	264	63.8	(103.0)	40
26	272	258	258	63.3	(102.5)	38
25	266	253	253	62.8	(101.5)	38
24	260	247	247	62.4	(101.0)	37
23	254	243	243	62.0	100.0	36
22	248	237	237	61.5	99.0	35
21	243	231	231	61.0	98.5	35
20	238	226	226	60.5	97.8	34
(18)	230	219	219	—	96.7	33
(16)	222	212	212	—	95.5	32
(14)	213	203	203	—	93.9	31
(12)	204	194	194	—	92.3	29
(10)	196	187	187	—	90.7	28
(8)	188	179	179	—	89.5	27
(6)	180	171	171	—	87.1	26
(4)	173	165	165	—	85.5	25
(2)	166	158	158	—	83.5	24
(0)	160	152	152	—	81.7	24

## ● Tolerance of Shaft Diameter

unit : μm

Nominal Diameter mm		b12		c12		d6		e6		e12		f5		f6		g5	
Over	Incl.	High	Low	High	Low	High	Low	High	Low	High	Low	High	Low	High	Low	High	Low
—	3	-140	-240	-60	-160	-20	-26	-14	-20	-14	-114	-6	-10	-6	-12	-2	-6
3	6	-140	-260	-70	-190	-30	-38	-20	-28	-20	-140	-10	-15	-10	-18	-4	-9
6	10	-150	-300	-80	-230	-40	-49	-25	-34	-25	-175	-13	-19	-13	-22	-5	-11
10	18	-150	-330	-95	-275	-50	-61	-32	-43	-32	-212	-16	-24	-16	-27	-6	-14
18	30	-160	-370	-110	-320	-65	-78	-40	-53	-40	-250	-20	-29	-20	-33	-7	-16
30	40	-170	-420	-120	-370	-80	-96	-50	-66	-50	-300	-25	-36	-25	-41	-9	-20
40	50	-180	-430	-130	-380	-80	-96	-50	-66	-50	-300	-25	-36	-25	-41	-9	-20
50	65	-190	-490	-140	-440	-100	-119	-60	-79	-60	-360	-30	-43	-30	-49	-10	-23
65	80	-200	-500	-150	-450	-100	-119	-60	-79	-60	-360	-30	-43	-30	-49	-10	-23
80	100	-220	-570	-170	-520	-120	-142	-72	-94	-72	-422	-36	-51	-36	-58	-12	-27
100	120	-240	-590	-180	-530	-120	-142	-72	-94	-72	-422	-36	-51	-36	-58	-12	-27
120	140	-260	-660	-200	-600	-145	-170	-85	-110	-85	-485	-43	-61	-43	-68	-14	-32
140	160	-280	-680	-210	-610	-145	-170	-85	-110	-85	-485	-43	-61	-43	-68	-14	-32
160	180	-310	-710	-230	-630	-145	-170	-85	-110	-85	-485	-43	-61	-43	-68	-14	-32
180	200	-340	-800	-240	-700	-170	-199	-100	-129	-100	-560	-50	-70	-50	-79	-15	-35
200	225	-380	-840	-260	-720	-170	-199	-100	-129	-100	-560	-50	-70	-50	-79	-15	-35
225	250	-420	-880	-280	-740	-170	-199	-100	-129	-100	-560	-50	-70	-50	-79	-15	-35
250	280	-480	-1000	-300	-820	-190	-222	-110	-142	-110	-630	-56	-79	-56	-88	-17	-40
280	315	-540	-1060	-330	-850	-190	-222	-110	-142	-110	-630	-56	-79	-56	-88	-17	-40
315	355	-600	-1170	-360	-930	-210	-246	-125	-161	-125	-695	-62	-87	-62	-98	-18	-43
355	400	-680	-1250	-400	-970	-210	-246	-125	-161	-125	-695	-62	-87	-62	-98	-18	-43
400	450	-760	-1390	-440	-1070	-230	-270	-135	-175	-135	-765	-68	-95	-68	-108	-20	-47
450	500	-840	-1470	-480	-1110	-230	-270	-135	-175	-135	-765	-68	-95	-68	-108	-20	-47

Nominal Diameter mm		g6		h5		h6		h7		h8		h9		h10		h11		Nominal Diameter mm	
High	Low	High	Low	High	Low	High	Low	High	Low	High	Low	High	Low	High	Low	High	Low	Over	Incl.
-2	-8	0	-4	0	-6	0	-10	0	-14	0	-18	0	-25	0	-40	0	-60	—	3
-4	-12	0	-5	0	-8	0	-12	0	-18	0	-22	0	-30	0	-48	0	-75	3	6
-5	-14	0	-6	0	-9	0	-15	0	-22	0	-27	0	-36	0	-58	0	-90	6	10
-6	-17	0	-8	0	-11	0	-18	0	-27	0	-33	0	-43	0	-70	0	-110	10	18
-7	-20	0	-9	0	-13	0	-21	0	-33	0	-41	0	-52	0	-84	0	-130	18	30
-9	-25	0	-11	0	-16	0	-25	0	-39	0	-49	0	-62	0	-100	0	-160	30	40
-10	-29	0	-13	0	-19	0	-30	0	-46	0	-58	0	-74	0	-120	0	-190	40	50
-12	-34	0	-15	0	-22	0	-35	0	-54	0	-70	0	-87	0	-140	0	-220	50	65
-12	-34	0	-15	0	-22	0	-35	0	-54	0	-70	0	-87	0	-140	0	-220	65	80
-14	-39	0	-18	0	-25	0	-40	0	-63	0	-84	0	-100	0	-160	0	-250	80	100
-14	-39	0	-18	0	-25	0	-40	0	-63	0	-84	0	-100	0	-160	0	-250	100	120
-15	-44	0	-20	0	-29	0	-46	0	-72	0	-115	0	-185	0	-290	0	-360	120	140
-15	-44	0	-20	0	-29	0	-46	0	-72	0	-115	0	-185	0	-290	0	-360	140	160
-17	-49	0	-23	0	-32	0	-52	0	-81	0	-130	0	-210	0	-320	0	-400	160	180
-17	-49	0	-23	0	-32	0	-52	0	-81	0	-130	0	-210	0	-320	0	-400	180	200
-18	-54	0	-25	0	-36	0	-57	0	-89	0	-140	0	-230	0	-360	0	-450	200	225
-18	-54	0	-25	0	-36	0	-57	0	-89	0	-140	0	-230	0	-360	0	-450	225	250
-20	-60	0	-27	0	-40	0	-63	0	-97	0	-155	0	-250	0	-400	0	-500	250	280
-20	-60	0	-27	0	-40	0	-63	0	-97	0	-155	0	-250	0	-400	0	-500	280	315
-20	-60	0	-27	0	-40	0	-63	0	-97	0	-155	0	-250	0	-400	0	-500	315	355
-20	-60	0	-27	0	-40	0	-63	0	-97	0	-155	0	-250	0	-400	0	-500	355	400
-20	-60	0	-27	0	-40	0	-63	0	-97	0	-155	0	-250	0	-400	0	-500	400	450
-20	-60	0	-27	0	-40	0	-63	0	-97	0	-155	0	-250	0	-400	0	-500	450	500

Nominal Diameter mm		h12		js5		j5		js6		j6		j7		k5		k6	
Over	Incl.	High	Low	High	Low	High	Low	High	Low	High	Low	High	Low	High	Low	High	Low
—	3	0	-100	+2	-2	+2	-2	+3	-3	+4	-2	+6	-4	+4	0	+6	0
3	6	0	-120	+2.5	-2.5	+3	-2	+4	-4	+6	-2	+8	-4	+6	+1	+9	+1
6	10	0	-150	+3	-3	+4	-2	+4.5	-4.5	+7	-2	+10	-5	+7	+1	+10	+1
10	18	0	-180	+4	-4	+5	-3	+5.5	-5.5	+8	-3	+12	-6	+9	+1	+12	+1
18	30	0	-210	+4.5	-4.5	+5	-4	+6.5	-6.5	+9	-4	+13	-8	+11	+2	+15	+2
30	40	0	-250	+5.5	-5.5	+6	-5	+8	-8	+11	-5	+15	-10	+13	+2	+18	+2
40	50	0	-250	+5.5	-5.5	+6	-5	+8	-8	+11	-5	+15	-10	+13	+2	+18	+2
50	65	0	-300	+6.5	-6.5	+6	-7	+9.5	-9.5	+12	-7	+18	-12	+15	+2	+21	+2
65	80	0	-300	+6.5	-6.5	+6	-7	+9.5	-9.5	+12	-7	+18	-12	+15	+2	+21	+2
80	100	0	-350	+7.5	-7.5	+6	-9	+11	-11	+13	-9	+20	-15	+18	+3	+25	+3
100	120	0	-350	+7.5	-7.5	+6	-9	+11	-11	+13	-9	+20	-15	+18	+3	+25	+3
120	140	0	-400	+9	-9	+7	-11	+12.5	-12.5	+14	-11	+22	-18	+21	+3	+28	+3
140	160	0	-400	+9	-9	+7	-11	+12.5	-12.5	+14	-11	+22	-18	+21	+3	+28	+3
160	180	0	-400	+9	-9	+7	-11	+12.5	-12.5	+14	-11	+22	-18	+21	+3	+28	+3
180	200	0	-460	+10	-10	+7	-13	+14.5	-14.5	+16	-13	+25	-21	+24	+4	+33	+4
200	225	0	-460	+10	-10	+7	-13	+14.5	-14.5	+16	-13	+25	-21	+24	+4	+33	+4
225	250	0	-460	+10	-10	+7	-13	+14.5	-14.5	+16	-13	+25	-21	+24	+4	+33	+4
250	280	0	-520	+11.5	-11.5	+7	-16	+16	-16	+16	-16	+26	-26	+27	+4	+36	+4
280	315	0	-520	+11.5	-11.5	+7	-16	+16	-16	+16	-16	+26	-26	+27	+4	+36	+4
315	355	0	-570	+12.5	-12.5	+7	-18	+18	-18	+18	-18	+29	-28	+29	+4	+40	+4
355	400	0	-570	+12.5	-12.5	+7	-18	+18	-18	+18	-18	+29	-28	+29	+4	+40	+4
400	450	0	-630	+13.5	-13.5	+7	-20	+20	-20	+20	-20	+31	-32	+32	+5	+45	+5
450	500	0	-630	+13.5	-13.5	+7	-20	+20	-20	+20	-20	+31	-32	+32	+5	+45	+5

unit : μm

Nominal Diameter mm		m5		m6		n5		n6		p6		Nominal Diameter mm	
High	Low	High	Low	High	Low	High	Low	High	Low	High	Low	Over	Incl.
+6	+2	+8	+2	+8	+4	+10	+4	+12	+6	—	—	—	3
+9	+4	+12	+4	+13	+8	+16	+8	+20	+12	3	3	3	6
+12	+6	+15	+6	+16	+10	+19	+10	+24	+15	6	6	6	10
+15	+7	+18	+7	+20	+12	+23	+12	+29	+18	10	10	10	18
+17	+8	+21	+8	+24	+15	+28	+15	+35	+22	18	18	18	30
+20	+9	+25	+9	+28	+17	+33	+17	+42	+26	30	30	30	40
+20	+9	+25	+9	+28	+17	+33	+17	+42	+26	40	40	40	50
+24	+11	+30	+11	+33	+20	+39	+20	+51	+32	50	50	50	65
+24	+11	+30	+11	+33	+20	+39	+20	+51	+32	65	65	65	80
+28	+13	+35	+13	+38	+23	+45	+23	+59	+37	80	80	80	100
+28	+13	+35	+13	+38	+23	+45	+23	+59	+37	100	100	100	120
+33	+15	+40	+15	+45	+27	+52	+27	+68	+43	120	120	120	140
+33	+15	+40	+15	+45	+27	+52	+27	+68	+43	140	140	140	160
+37	+17	+46	+17	+51	+31	+60	+31	+79	+50	160	160	160	180
+37	+17	+46	+17	+51	+31	+60	+31	+79	+50	180	180	180	200
+43	+20	+52	+20	+57	+34	+66	+34	+88	+56	200	200	200	225
+43	+20	+52	+20	+57	+34								



## ● Tolerance of Housing Bore Diameter

unit :  $\mu\text{m}$

Nominal Diameter mm		B12		E7		E11		E12		F6		F7		G6		G7	
Over	Incl.	High	Low	High	Low	High	Low	High	Low	High	Low	High	Low	High	Low	High	Low
—	3	+240	+140	+24	+14	+74	+14	+114	+14	+12	+6	+16	+6	+8	+2	+12	+2
3	6	+260	+140	+32	+20	+95	+20	+140	+20	+18	+10	+22	+10	+12	+4	+16	+4
6	10	+300	+150	+40	+25	+115	+25	+175	+25	+22	+13	+28	+13	+14	+5	+20	+5
10	18	+330	+150	+50	+32	+142	+32	+212	+32	+27	+16	+34	+16	+17	+6	+24	+6
18	30	+370	+160	+61	+40	+170	+40	+250	+40	+33	+20	+41	+20	+20	+7	+28	+7
30	40	+420	+170	+75	+50	+210	+50	+300	+50	+41	+25	+50	+25	+25	+9	+34	+9
40	50	+430	+180														
50	65	+490	+190	+90	+60	+250	+60	+360	+60	+49	+30	+60	+30	+29	+10	+40	+10
65	80	+500	+200														
80	100	+570	+220	+107	+72	+292	+72	+422	+72	+58	+36	+71	+36	+34	+12	+47	+12
100	120	+590	+240														
120	140	+660	+260														
140	160	+680	+280	+125	+85	+335	+85	+485	+85	+68	+43	+83	+43	+39	+14	+54	+14
160	180	+710	+310														
180	200	+800	+340														
200	225	+840	+380	+146	+100	+390	+100	+560	+100	+79	+50	+96	+50	+44	+15	+61	+15
225	250	+880	+420														
250	280	+1000	+480	+162	+110	+430	+110	+630	+110	+88	+56	+108	+56	+49	+17	+69	+17
280	315	+1060	+540														
315	355	+1170	+600	+182	+125	+485	+125	+695	+125	+98	+62	+119	+62	+54	+18	+75	+18
355	400	+1250	+680														
400	450	+1390	+760	+198	+135	+535	+135	+765	+135	+108	+68	+131	+68	+60	+20	+83	+20
450	500	+1470	+840														

H6		H7		H8		H9		H10		H11		JS6		J6		Nominal Diameter mm	
High	Low	High	Low	High	Low	High	Low	High	Low	High	Low	High	Low	High	Low	Over	Incl.
+6	0	+10	0	+14	0	+25	0	+40	0	+60	0	+3	-3	+2	-4	—	3
+8	0	+12	0	+18	0	+30	0	+48	0	+75	0	+4	-4	+5	-3	3	6
+9	0	+15	0	+22	0	+36	0	+58	0	+90	0	+4.5	-4.5	+5	-4	6	10
+11	0	+18	0	+27	0	+43	0	+70	0	+110	0	+5.5	-5.5	+6	-5	10	18
+13	0	+21	0	+33	0	+52	0	+84	0	+130	0	+6.5	-6.5	+8	-5	18	30
+16	0	+25	0	+39	0	+62	0	+100	0	+160	0	+8	-8	+10	-6	30	40
																40	50
+19	0	+30	0	+46	0	+74	0	+120	0	+190	0	+9.5	-9.5	+13	-6	50	65
																65	80
+22	0	+35	0	+54	0	+87	0	+140	0	+220	0	+11	-11	+16	-6	80	100
																100	120
+25	0	+40	0	+63	0	+100	0	+160	0	+250	0	+12.5	-12.5	+18	-7	120	140
																140	160
																160	180
+29	0	+46	0	+72	0	+115	0	+185	0	+290	0	+14.5	-14.5	+22	-7	180	200
																200	225
																225	250
+32	0	+52	0	+81	0	+130	0	+210	0	+320	0	+16	-16	+25	-7	250	280
																280	315
+36	0	+57	0	+89	0	+140	0	+230	0	+360	0	+18	-18	+29	-7	315	355
																355	400
+40	0	+63	0	+97	0	+155	0	+250	0	+400	0	+20	-20	+33	-7	400	450
																450	500

Nominal Diameter mm		JS7		J7		K5		K6		K7		M6		M7		N6	
Over	Incl.	High	Low	High	Low	High	Low	High	Low	High	Low	High	Low	High	Low	High	Low
—	3	+5	-5	+4	-6	0	-4	0	-6	0	-10	-2	-8	-2	-12	-4	-10
3	6	+6	-6	+6	-6	0	-5	+2	-6	+3	-9	-1	-9	0	-12	-5	-13
6	10	+7	-7	+8	-7	+1	-5	+2	-7	+5	-10	-3	-12	0	-15	-7	-16
10	18	+9	-9	+10	-8	+2	-6	+2	-9	+6	-12	-4	-15	0	-18	-9	-20
18	30	+10	-10	+12	-9	+1	-8	+2	-11	+6	-15	-4	-17	0	-21	-11	-24
30	40	+12	-12	+14	-11	+2	-9	+3	-13	+7	-18	-4	-20	0	-25	-12	-28
40	50																
50	65	+15	-15	+18	-12	+3	-10	+4	-15	+9	-21	-5	-24	0	-30	-14	-33
65	80																
80	100	+17	-17	+22	-13	+2	-13	+4	-18	+10	-25	-6	-28	0	-35	-16	-38
100	120																
120	140	+20	-20	+26	-14	+3	-15	+4	-21	+12	-28	-8	-33	0	-40	-20	-45
140	160																
160	180																
180	200																
200	225	+23	-23	+30	-16	+2	-18	+5	-24	+13	-33	-8	-37	0	-46	-22	-51
225	250																
250	280	+26	-26	+36	-16	+3	-20	+5	-27	+16	-36	-9	-41	0	-52	-25	-57
280	315																
315	355	+28	-28	+39	-18	+3	-22	+7	-29	+17	-40	-10	-46	0	-57	-26	-62
355	400																
400	450	+31	-31	+43	-20	+2	-25	+8	-32	+18	-45	-10	-50	0	-63	-27	-67
450	500																

unit :  $\mu\text{m}$

N7		P6		P7		R7		S7		Nominal Diameter mm	
High	Low	High	Low	High	Low	High	Low	High	Low	Over	Incl.
-4	-14	-6	-12	-6	-16	-10	-20	-14	-24	—	3
-4	-16	-9	-17	-8	-20	-11	-23	-15	-27	3	6
-4	-19	-12	-21	-9	-24	-13	-28	-17	-32	6	10
-5	-23	-15	-26	-11	-29	-16	-34	-21	-39	10	18
-7	-28	-18	-31	-14	-35	-20	-41	-27	-48	18	30
-8	-33	-21	-37	-17	-42	-25	-50	-34	-59	30	40
										40	50
-9	-39	-26	-45	-21	-51	-30	-60	-42	-72	50	65
										65	80
-10	-45	-30	-52	-24	-59	-38	-73	-58	-93	80	100
										100	120
-12	-52	-36	-61	-28	-68	-48	-88	-77	-117	120	140
										140	160
										160	180
-14	-60	-41	-70	-33	-79	-60	-106	-105	-151	180	200
										200	225
										225	250
-14	-66	-47	-79	-36	-88	-74	-126	-138	-190	250	280
										280	315
-16	-73	-51	-87	-41	-98	-87	-144	-169	-226	315	355
										355	400
-17	-80	-55	-95	-45	-108	-103	-166	-209	-272	400	450
										450	500

## N-lbf Conversion Table

N		lbf	N		lbf
4.448	1	0.225	151.24	34	7.643
8.896	2	0.450	155.69	35	7.868
13.345	3	0.674	160.14	36	8.093
17.793	4	0.899	164.58	37	8.318
22.241	5	1.124	169.03	38	8.543
26.689	6	1.349	173.48	39	8.768
31.138	7	1.574	177.93	40	8.992
35.586	8	1.798	182.38	41	9.217
40.034	9	2.023	186.83	42	9.442
44.482	10	2.248	191.27	43	9.667
48.930	11	2.473	195.72	44	9.892
53.379	12	2.698	200.17	45	10.116
57.827	13	2.923	204.62	46	10.341
62.275	14	3.147	209.07	47	10.566
66.723	15	3.372	213.51	48	10.791
71.171	16	3.597	217.96	49	11.016
75.620	17	3.822	222.41	50	11.240
80.068	18	4.047	226.86	51	11.465
84.516	19	4.271	231.31	52	11.690
88.964	20	4.496	235.76	53	11.915
93.413	21	4.721	240.20	54	12.140
97.861	22	4.946	244.65	55	12.364
102.31	23	5.171	249.10	56	12.589
106.76	24	5.395	253.55	57	12.814
111.21	25	5.620	258.00	58	13.039
115.65	26	5.845	262.44	59	13.264
120.10	27	6.070	266.89	60	13.489
124.55	28	6.295	271.34	61	13.713
129.00	29	6.519	275.79	62	13.938
133.45	30	6.744	280.24	63	14.163
137.89	31	6.969	284.69	64	14.388
142.34	32	7.194	289.13	65	14.613
146.79	33	7.419	293.58	66	14.837

1N = 0.224809 lbf 1lbf = 4.44822 N

N		lbf	N		lbf
298.03	67	15.062	320.27	72	16.186
302.48	68	15.287	324.72	73	16.411
306.93	69	15.512	329.17	74	16.636
311.38	70	15.737	333.62	75	16.861
315.82	71	15.961	338.06	76	17.085
320.27	72	16.186	342.51	77	17.310
324.72	73	16.411	346.96	78	17.535
329.17	74	16.636	351.41	79	17.760
333.62	75	16.861	355.86	80	17.985
338.06	76	17.085	360.31	81	18.210
364.75	82	18.434	364.75	82	18.434
369.20	83	18.659	369.20	83	18.659
373.65	84	18.884	373.65	84	18.884
378.10	85	19.109	378.10	85	19.109
382.55	86	19.334	382.55	86	19.334
386.99	87	19.558	386.99	87	19.558
391.44	88	19.783	391.44	88	19.783
395.89	89	20.008	395.89	89	20.008
400.34	90	20.233	400.34	90	20.233
404.79	91	20.458	404.79	91	20.458
409.24	92	20.682	409.24	92	20.682
413.68	93	20.907	413.68	93	20.907
418.13	94	21.132	418.13	94	21.132
422.58	95	21.357	422.58	95	21.357
427.03	96	21.582	427.03	96	21.582
431.48	97	21.806	431.48	97	21.806
435.93	98	22.031	435.93	98	22.031
440.37	99	22.256	440.37	99	22.256

**How to use :** For example, to convert 20 N into lbf, find the number 20 in the center of the first column. By referring to the lbf column on the right, it will be found that 20 N equals 4.496 lbf.  
To convert 20 lbf into N, refer to the N column on the left and it will be found that 20 lbf equals 88.964 N.

## N-kgf Conversion Table

N		kgf	N		kgf
9.8066	1	0.1020	333.43	34	3.4670
19.613	2	0.2039	343.23	35	3.5690
29.420	3	0.3059	353.04	36	3.6710
39.227	4	0.4079	362.85	37	3.7729
49.033	5	0.5099	372.65	38	3.8749
58.840	6	0.6118	382.46	39	3.9769
68.647	7	0.7138	392.27	40	4.0789
78.453	8	0.8158	402.07	41	4.1808
88.260	9	0.9177	411.88	42	4.2828
98.066	10	1.0197	421.69	43	4.3848
107.87	11	1.1217	431.49	44	4.4868
117.68	12	1.2237	441.30	45	4.5887
127.49	13	1.3256	451.11	46	4.6907
137.29	14	1.4276	460.91	47	4.7927
147.10	15	1.5296	470.72	48	4.8946
156.91	16	1.6315	480.53	49	4.9966
166.71	17	1.7335	490.33	50	5.0986
176.52	18	1.8355	500.14	51	5.2006
186.33	19	1.9375	509.95	52	5.3025
196.13	20	2.0394	519.75	53	5.4045
205.94	21	2.1414	529.56	54	5.5065
215.75	22	2.2434	539.37	55	5.6084
225.55	23	2.3453	549.17	56	5.7104
235.36	24	2.4473	558.98	57	5.8124
245.17	25	2.5493	568.79	58	5.9144
254.97	26	2.6513	578.59	59	6.0163
264.78	27	2.7532	588.40	60	6.1183
274.59	28	2.8552	598.21	61	6.2203
284.39	29	2.9572	608.01	62	6.3222
294.20	30	3.0591	617.82	63	6.4242
304.01	31	3.1611	627.63	64	6.5262
313.81	32	3.2631	637.43	65	6.6282
323.62	33	3.3651	647.24	66	6.7301

1N = 0.1019716 kgf 1kgf = 9.80665 N

N		kgf	N		kgf
657.05	67	6.8321	706.08	72	7.3420
666.85	68	6.9341	715.89	73	7.4439
676.66	69	7.0360	725.69	74	7.5459
686.47	70	7.1380	735.50	75	7.6479
696.27	71	7.2400	745.31	76	7.7498
706.08	72	7.3420	755.11	77	7.8518
715.89	73	7.4439	764.92	78	7.9538
725.69	74	7.5459	774.73	79	8.0558
735.50	75	7.6479	784.53	80	8.1577
745.31	76	7.7498	794.34	81	8.2597
755.11	77	7.8518	804.15	82	8.3617
764.92	78	7.9538	813.95	83	8.4636
774.73	79	8.0558	823.76	84	8.5656
784.53	80	8.1577	833.57	85	8.6676
794.34	81	8.2597	843.37	86	8.7696
804.15	82	8.3617	853.18	87	8.8715
813.95	83	8.4636	862.99	88	8.9735
823.76	84	8.5656	872.79	89	9.0755
833.57	85	8.6676	882.60	90	9.1774
843.37	86	8.7696	892.41	91	9.2794
853.18	87	8.8715	902.21	92	9.3814
862.99	88	8.9735	912.02	93	9.4834
872.79	89	9.0755	921.83	94	9.5853
882.60	90	9.1774	931.63	95	9.6873
892.41	91	9.2794	941.44	96	9.7893
902.21	92	9.3814	951.25	97	9.8912
912.02	93	9.4834	961.05	98	9.9932
921.83	94	9.5853	970.86	99	10.0952

**How to use :** For example, to convert 20 N into kgf, find the number 20 in the center of the first column. By referring to the kgf column on the right, it will be found that 20 N equals 2.0394 kgf.  
To convert 20 kgf into N, refer to the N column on the left and it will be found that 20 kgf equals 196.13 N.

## ● Temperature Conversion Table

°C	°F		°C	°F		°C	°F		°C	°F	
-73.3	-100	-148.0	-2.2	28	82.4	16.1	61	141.8	34.4	94	201.2
-62.2	- 80	-112.0	-1.7	29	84.2	16.7	62	143.6	35.0	95	203.0
-51.1	- 60	- 76.0	-1.1	30	86.0	17.2	63	145.4	35.6	96	204.8
-40.0	- 40	- 40.0	-0.6	31	87.8	17.8	64	147.2	36.1	97	206.6
-28.9	- 20	- 4.0	0	32	89.6	18.3	65	149.0	36.7	98	208.4
-17.8	0	32.0	0.6	33	91.4	18.9	66	150.8	37.2	99	210.2
-17.2	1	33.8	1.1	34	93.2	19.4	67	152.6	37.8	100	212
-16.7	2	35.6	1.7	35	95.0	20.0	68	154.4	43.3	110	230
-16.1	3	37.4	2.2	36	96.8	20.6	69	156.2	48.9	120	248
-15.6	4	39.2	2.8	37	98.6	21.1	70	158.0	54.4	130	266
-15.0	5	41.0	3.3	38	100.4	21.7	71	159.8	60.0	140	284
-14.4	6	42.8	3.9	39	102.2	22.2	72	161.6	65.6	150	302
-13.9	7	44.6	4.4	40	104.0	22.8	73	163.4	71.1	160	320
-13.3	8	46.4	5.0	41	105.8	23.3	74	165.2	76.7	170	338
-12.8	9	48.2	5.6	42	107.6	23.9	75	167.0	82.2	180	356
-12.2	10	50.0	6.1	43	109.4	24.4	76	168.8	87.8	190	374
-11.7	11	51.8	6.7	44	111.2	25.0	77	170.6	93.3	200	392
-11.1	12	53.6	7.2	45	113.0	25.6	78	172.4	121.1	250	482
-10.6	13	55.4	7.8	46	114.8	26.1	79	174.2	149	300	572
-10.0	14	57.2	8.3	47	116.6	26.7	80	176.0	177	350	662
- 9.4	15	59.0	8.9	48	118.4	27.2	81	177.8	204	400	752
- 8.9	16	60.8	9.4	49	120.2	27.8	82	179.6	232	450	842
- 8.3	17	62.6	10.0	50	122.0	28.3	83	181.4	260	500	932
- 7.8	18	64.4	10.6	51	123.8	28.9	84	183.2	288	550	1022
- 7.2	19	66.2	11.1	52	125.6	29.4	85	185.0	316	600	1112
- 6.7	20	68.0	11.7	53	127.4	30.0	86	186.8	343	650	1202
- 6.1	21	69.8	12.2	54	129.2	30.6	87	188.6	371	700	1292
- 5.6	22	71.6	12.8	55	131.0	31.1	88	190.4	399	750	1382
- 5.0	23	73.4	13.3	56	132.8	31.7	89	192.2	427	800	1472
- 4.4	24	75.2	13.9	57	134.6	32.2	90	194.0	454	850	1562
- 3.9	25	77.0	14.4	58	136.4	32.8	91	195.8	482	900	1652
- 3.3	26	78.8	15.0	59	138.2	33.3	92	197.6	510	950	1742
- 2.8	27	80.6	15.6	60	140.0	33.9	93	199.4	538	1000	1832

$$C = \frac{5}{9} (F-32) \quad F = 32 + \frac{9}{5} C$$

**How to use :** For example, to convert 20°C into °F, find the number 20 in the center of the first column. By referring the °F column on the right, it will be found that 20°C equals 68.0°F.

To convert 20°F into °C, refer to the °C column on the left and it will be found that 20°F equals -6.7°C.

## ● Grease names and the characteristics (Also see page 48)

Sort	Name	Supplier	Thickener of metallic soap	Consistency	Dropping point (°C)	Service range(°) (°C)	Remarks
General purpose	ALVANIA GREASE No.1	SHELL	Li	326	180	-35~+120	General, Centralized greasing
	ALVANIA GREASE No.2	SHELL	Li	273	182	-25~+120	General, Centralized greasing
	ALVANIA GREASE No.3	SHELL	Li	232	183	-20~+135	General
	DAPHNE EPONEX GREASE No.2	IDEMITSU	Li	276	195	-20~+120	General
	COSMO GREASE DYNAMAX No.2	COSMO	Li	280	188	-20~+120	General
	MULTINOC GREASE 2	NIPPON OIL	Li	278	212	-30~+125	General
	MOBILAX GREASE No.2	MOBIL	Li	280	196	-35~+120	General
Low temperature	ALVANIA GREASE RA	SHELL	Li	252	183	-40~+130	Low temperature
	BEACON 325	ESSO	Li	280	193	-60~ <sup>(+160)</sup> +120	Low temperature, Low torque
	ISOFLEX LDS 18 SPECIAL A	KLÜBER	Li	280	≥185	-60~+130	Low temperature, High speed, Extreme pressure
	ISOFLEX SUPER LDS 18	KLÜBER	Li	280	≥185	-60~+130	Low temperature, High speed, Low noise
	LT GREASE No.2	JAPAN ENERGY	Li	275	181	-50~+150	Low temperature
Wide temperature range	TEMPREX N3	ESSO	Li Complex	235	≥300	-20~ <sup>(+200)</sup> +160	Wide temperature range, High temperature
	AEROSHELL GREASE 7	SHELL	Microgel	288	≥260	-73~+149	Wide temperature range, Low temperature
	MULTEMP PS No.2	KYODO YUSHI	Li	275	190	-50~+130	Wide temperature range, For low temperature & low noise
	MULTEMP SRL	KYODO YUSHI	Li	242	192	-50~+150	Wide temperature range, For low temperature & low noise
	MULTINOC WIDE No.2	NIPPON OIL	Li+special Na	247	203	-40~+135	Wide temperature range
Extreme pressure	ALVANIA EP-2	SHELL	Li	276	187	-20~+110	Extreme pressure, Centralized greasing
	MOLYKOTE BR2-PLUS	DOW CORNING	Li	265	185	-30~+150	With MoS <sub>2</sub> , Extreme pressure
	MOLUB-ALLOY #777-2	CASTROL	Li	280	182	0~+135	With MoS <sub>2</sub> , Extreme pressure
Others	G 40M	SHIN-ETSU	Li	260	≥200	-30~+200	Wide temperature range, Superior at high temperature with stable anti-oxidation and water proof, Chemically inert
	G 40H	SHIN-ETSU	Li	220	≥200	-30~+200	Wide temperature range, Superior at high temperature with stable anti-oxidation and water proof, Chemically inert
	KRYTOX 240AD	DU PONT	Fluorinated	275	None	-30~+288	Stabl at high temperature, Chemically inert, Anti-solvent
	BARRIERTA L55/2	KLÜBER	Fluorinated	No.2	None	-35~ <sup>(+250)</sup> +220	General, Low evaporation at high temperature, Chemically inert
	BARRIERTA IMI/V	KLÜBER	Fluorinated	No.2	None	-50~+220	For high vacuum
	DEMNUM GREASE L-200	DAIKIN	Fluorinated	280	None	-60~+300	Stabl at high temperature, Anti-solvent, Chemically inert
	DOLIUM GREASE R	SHELL	Polyurea	281	249	-30~+150	Heat resistant, Superior at high temperature with stable anti-oxidation
	STAMINA GREASE RL2	SHELL	Polyurea	268	271	-20~+180	Heat resistant, Superior at high temperature with stable anti-oxidation

**Note(!)** : Figures in parentheses show the maximum allowable temperature in very short time operation, and they are not applicable for continuous operation.

**Remark** : When using these products, see individual manufacturer's catalogs.

# Linear Products CAD Data

We can supply CAD data for **IKO** Linear Motion Rolling Guides including the Linear Way and Linear Roller Way series. We hope this data is useful for customer's design efficiently. If this data is required, Please visit **IKO** web site <http://www.ikont.com/resister.htm>

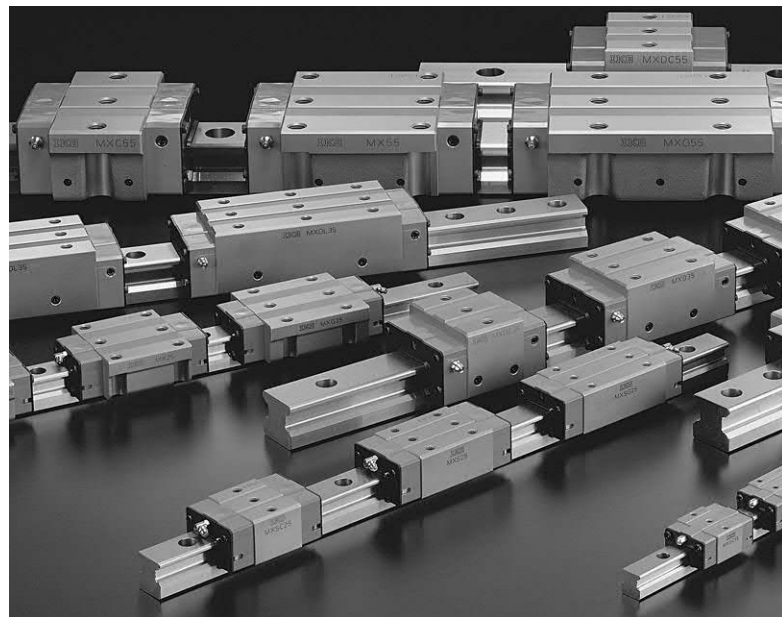

## Types of CAD Data Formats : DXF and other formats (2D and 3D)

## Products Described

### Linear Motion Rolling Guide series

- C-Lube Linear Way ML and Linear Way L
- C-Lube Linear Way ME and Linear Way E
- C-Lube Linear Way MH and Linear Way H
- C-Lube Linear Way MUL and Linear Way U
- C-Lube Linear Roller Way Super MX
- C-Lube Linear Ball Spline MAG
- Linear Roller Way Super X
- Linear Way F
- Linear Way Module
- Linear Ball Spline G
- Stroke Ball Spline LS
- Block type Linear Ball Spline
- High Rigidity Precision Linear Slide Unit
- Precision Linear Slide
- Linear Bushing G

### Mechatronic Product series

- Precision Positioning Table TU

## Data Included

The data includes three drawings of front view, side view, and plane view. The scale is 1:1 (actual size) and no dimension line is shown.

## Precautions

- ① When reading the graphic data of the **IKO** Linear Motion series CAD data collections by using your CAD system, first check the CAD system instruction manual.
- ② The graphic data of the **IKO** Linear Motion series CAD data collections is subject to change without notice for improvement purposes.
- ③ We shall disclaim all responsibility for any damages that may result from using this collection of data.

Product names marked with an asterisk (\*) represent the trademark or registered trademark of Autodesk.

# Index of Model Codes

<b>B</b>			LBB...UU OP E-150 Linear Bushing	LM...N UU OP E-158 Linear Bushing	LME...UU AJ E-162 Linear Bushing
BG E-211 Stroke Rotary Cage	LBD E-144 Linear Bushing	LM...OP E-152 Linear Bushing	LME...UU OP E-162 Linear Bushing		
BK...A E-204 Miniature Stroke Rotary Bushing	LBD...AJ E-144 Linear Bushing	LM...UU E-158 Linear Bushing	LMG E-128 Linear Bushing G		
BSP...SL E-112 Precision Linear Slide	LBD...OP E-144 Linear Bushing	LM...UU AJ E-158 Linear Bushing	LMGT E-128 Linear Bushing G		
BSPG...SL E-114 Precision Linear Slide	LBD...UU E-146 Linear Bushing	LM...UU OP E-158 Linear Bushing	LMS E-185 Miniature Linear Bushing		
BSR...SL E-116 Precision Linear Slide	LBD...UU AJ E-146 Linear Bushing	LMB E-164 Linear Bushing	LMS...F E-185 Miniature Linear Bushing		
BWU E-100 High Rigidity Precision Linear Slide Unit	LBD...UU OP E-146 Linear Bushing	LMB...AJ E-164 Linear Bushing	LMS...F UU E-185 Miniature Linear Bushing		
	LBE E-140 Linear Bushing	LMB...N E-164 Linear Bushing	LMS...UU E-185 Miniature Linear Bushing		
	LBE...AJ E-140 Linear Bushing	LMB...N AJ E-164 Linear Bushing	LMSL E-185 Miniature Linear Bushing		
	LBE...OP E-140 Linear Bushing	LMB...N OP E-164 Linear Bushing	LMSL...F E-185 Miniature Linear Bushing		
<b>C</b>			LBE...UU E-142 Linear Bushing	LMB...OP E-164 Linear Bushing	LMSL...F UU E-185 Miniature Linear Bushing
CRW E-50 Crossed Roller Way	LBE...UU AJ E-142 Linear Bushing	LME E-160 Linear Bushing	LMSL...UU E-185 Miniature Linear Bushing	LRX C-18 Linear Roller Way Super X	
CRWG E-16 Anti-Creep Cage Crossed Roller Way	LBE...UU OP E-142 Linear Bushing	LME...AJ E-160 Linear Bushing	LRXC C-18 Linear Roller Way Super X	LRXD C-22 Linear Roller Way Super X	
CRW...SL E-50 Crossed Roller Way	LK E-177 Compact Linear Bushing	LME...F E-170 Linear Bushing	LRXD...SL C-24 Linear Roller Way Super X	LRXDC C-24 Linear Roller Way Super X	
CRWM E-66 Crossed Roller Way	LM E-152 Linear Bushing	LME...F AJ E-170 Linear Bushing	LRXDC...SL C-24 Linear Roller Way Super X	LRXDC C-24 Linear Roller Way Super X	
CRWM...A E-70 Crossed Roller Way	LM...AJ E-152 Linear Bushing	LME...F OP E-170 Linear Bushing	LRXDG C-24 Linear Roller Way Super X	LRXDC...SL C-24 Linear Roller Way Super X	
CRWU E-78 Crossed Roller Way Unit	LM...F E-166 Linear Bushing	LME...F UU E-172 Linear Bushing	LRXDG...SL C-24 Linear Roller Way Super X	LRXG C-18 Linear Roller Way Super X	
CRWU...R E-84 Crossed Roller Way Unit	LM...F AJ E-166 Linear Bushing	LME...F UU AJ E-172 Linear Bushing	LRXSG C-28 Linear Roller Way Super X	LRXSC C-28 Linear Roller Way Super X	
CRWU...RS E-88 Crossed Roller Way Unit	LM...F OP E-166 Linear Bushing	LME...F UU OP E-172 Linear Bushing	LS D-58 Stroke Ball Spline LS	LRXSG C-28 Linear Roller Way Super X	
CRWUG E-24 Anti-Creep Cage Crossed Roller Way Unit	LM...F UU E-168 Linear Bushing	LME...N E-160 Linear Bushing	LSAG D-38 Linear Ball Spline G	LSAGF D-42 Linear Ball Spline G	
	LM...F UU AJ E-168 Linear Bushing	LME...N AJ E-160 Linear Bushing	LSAGFL D-42 Linear Ball Spline G	LSAGFLT D-42 Linear Ball Spline G	
	LM...F UU OP E-168 Linear Bushing	LME...N F E-170 Linear Bushing	LSAGFT D-42 Linear Ball Spline G	LSAGFLT D-42 Linear Ball Spline G	
<b>F</b>			LM...N E-152 Linear Bushing	LME...N F AJ E-170 Linear Bushing	LSAGLT D-38 Linear Ball Spline G
FT E-224 Flat Roller Cage	LM...N AJ E-152 Linear Bushing	LME...N F OP E-170 Linear Bushing	LME...N F UU AJ E-172 Linear Bushing	LSAGT D-38 Linear Ball Spline G	
FT...N E-224 Flat Roller Cage	LM...N F E-166 Linear Bushing	LME...N F UU E-172 Linear Bushing	LME...N F UU OPE-172 Linear Bushing		
FTW E-225 Flat Roller Cage	LM...N F AJ E-166 Linear Bushing	LME...N OP E-160 Linear Bushing	LME...N UU E-162 Linear Bushing		
	LM...N F OP E-166 Linear Bushing	LME...N UU AJ E-162 Linear Bushing	LME...OP E-160 Linear Bushing		
	LM...N F UU E-168 Linear Bushing	LME...N UU OP E-162 Linear Bushing	LME...UU E-162 Linear Bushing		
<b>L</b>			LM...N F UU AJ E-168 Linear Bushing		
LBB E-148 Linear Bushing	LM...N F UU OP E-168 Linear Bushing				
LBB...AJ E-148 Linear Bushing	LM...N OP E-152 Linear Bushing				
LBB...OP E-148 Linear Bushing	LM...N UU E-158 Linear Bushing				
LBB...UU E-150 Linear Bushing	LM...N UU AJ E-158 Linear Bushing				

# Index of Model Codes

<b>L</b>		
LSB	D-52	Block type Linear Ball Spline
LSB...SL	D-52	Block type Linear Ball Spline
LSBT	D-52	Block type Linear Ball Spline
LWE	B-44	Linear Way E
LWE...SL	B-44	Linear Way E
LWE...Q	B-68	Low Decibel Linear Way E
LWEC	B-44	Linear Way E
LWEC...SL	B-44	Linear Way E
LWEG	B-44	Linear Way E
LWEG...SL	B-44	Linear Way E
LWES	B-52	Linear Way E
LWES...SL	B-52	Linear Way E
LWES...Q	B-72	Low Decibel Linear Way E
LWESC	B-52	Linear Way E
LWESC...SL	B-52	Linear Way E
LWESG	B-52	Linear Way E
LWESG...SL	B-52	Linear Way E
LWET	B-48	Linear Way E
LWET...SL	B-48	Linear Way E
LWET...Q	B-70	Low Decibel Linear Way E
LWETC	B-48	Linear Way E
LWETC...SL	B-48	Linear Way E
LWETG	B-48	Linear Way E
LWETG...SL	B-48	Linear Way E
LWFF	B-126	Linear Way F
LWFH	B-124	Linear Way F
LWFS	B-128	Linear Way F
LWFS...SL	B-128	Linear Way F
LWH...B	B-94	Linear Way H
LWH...M	B-94	Linear Way H
LWH...SL	B-94	Linear Way H
LWHD	B-102	Linear Way H

LWHD...B	B-102	Linear Way H
LWHD...M	B-102	Linear Way H
LWHD...SL	B-102	Linear Way H
LWHDG	B-102	Linear Way H
LWHG	B-94	Linear Way H
LWHS...B	B-106	Linear Way H
LWHS...M	B-106	Linear Way H
LWHS...SL	B-106	Linear Way H
LWHSG	B-106	Linear Way H
LWHT	B-98	Linear Way H
LWHT...B	B-98	Linear Way H
LWHT...M	B-98	Linear Way H
LWHT...SL	B-98	Linear Way H
LWHTG	B-98	Linear Way H
LWHY	B-108	Linear Way H
LWL	B-16	Linear Way L
LWL...B	B-18	Linear Way L
LWL...B CS	B-20	Linear Way L
LWL...CS	B-20	Linear Way L
LWL...N	B-18	Linear Way L
LWL...Y	B-16	Linear Way L
LWLC	B-16	Linear Way L
LWLC...B	B-18	Linear Way L
LWLC...N	B-18	Linear Way L
LWLF	B-24	Linear Way L
LWLF...B	B-24	Linear Way L
LWLF...B CS	B-26	Linear Way L
LWLF...CS	B-26	Linear Way L
LWLF...N	B-24	Linear Way L
LWLFC	B-24	Linear Way L
LWLFC...B	B-24	Linear Way L
LWLFC...N	B-24	Linear Way L
LWLFG...B	B-24	Linear Way L

LWLFG...N	B-24	Linear Way L
LWLG...B	B-18	Linear Way L
LWLG...N	B-18	Linear Way L
LWLM	B-148	Linear Way Module
LWM	B-150	Linear Way Module
LWU	B-140	Linear Way U
LWU...B	B-138	Linear Way U
LWUL...B	B-138	Linear Way U
<b>M</b>		
MAG	A-106	C-Lube Linear Ball Spline MAG
MAGF	A-108	C-Lube Linear Ball Spline MAG
MAGFT	A-108	C-Lube Linear Ball Spline MAG
MAGT	A-106	C-Lube Linear Ball Spline MAG
ME	A-28	C-Lube Linear Way ME
MEC	A-28	C-Lube Linear Way ME
MEG	A-28	C-Lube Linear Way ME
MES	A-36	C-Lube Linear Way ME
MESC	A-36	C-Lube Linear Way ME
MESG	A-36	C-Lube Linear Way ME
MET	A-32	C-Lube Linear Way ME
METC	A-32	C-Lube Linear Way ME
METG	A-32	C-Lube Linear Way ME
MH	A-54	C-Lube Linear Way MH
MHD	A-58	C-Lube Linear Way MH
MHDC	A-58	C-Lube Linear Way MH
MHDG	A-58	C-Lube Linear Way MH
MHG	A-54	C-Lube Linear Way MH
MHS	A-60	C-Lube Linear Way MH
MHSG	A-60	C-Lube Linear Way MH
MHT	A-56	C-Lube Linear Way MH
MHTG	A-56	C-Lube Linear Way MH

ML	A-10	C-Lube Linear Way ML
MLC	A-10	C-Lube Linear Way ML
MLF	A-14	C-Lube Linear Way ML
MLFC	A-14	C-Lube Linear Way ML
MLFG	A-14	C-Lube Linear Way ML
MLG	A-10	C-Lube Linear Way ML
MUL	A-68	C-Lube Linear Way ML
MX	A-88	C-Lube Linear Roller Way MX
MXD	A-92	C-Lube Linear Roller Way MX
MXDG	A-92	C-Lube Linear Roller Way MX
MXG	A-88	C-Lube Linear Roller Way MX
MXN	A-96	C-Lube Linear Roller Way MX
MXNS	A-98	C-Lube Linear Roller Way MX
MXS	A-94	C-Lube Linear Roller Way MX
MXSG	A-94	C-Lube Linear Roller Way MX
<b>O</b>		
OR...A	E-192	Miniature Stroke Rotary Bushing
<b>S</b>		
SF...A	E-193	Miniature Stroke Rotary Bushing
SR	E-216	Roller Way
ST	E-194	Stroke Rotary Bushing
ST...B	E-194	Stroke Rotary Bushing
ST...UU	E-194	Stroke Rotary Bushing
ST...UUB	E-194	Stroke Rotary Bushing
STS	E-204	Miniature Stroke Rotary Bushing
STSI	E-205	Miniature Stroke Rotary Bushing

Although all data in this catalog has been carefully compiled to make the information as complete as possible, NIPPON THOMPSON CO., LTD. shall not be liable for any damages whatsoever, direct or indirect, based upon any information in this catalog. NIPPON THOMPSON CO., LTD. makes no warranty, either express or implied, including the implied warranty of merchantability or fitness for a particular purpose.

---

**NIPPON THOMPSON CO., LTD.**

CAT-5507.1 Printed in Japan 2009.03—OKU

# SERVICE NETWORK OF IKO PRODUCTS

## NIPPON THOMPSON CO., LTD.

■ Head office :19-19 Takanawa 2-chome Minato-ku,  
Tokyo 108-8586, Japan  
Phone :+81 (0)3-3448-5850  
Fax :+81 (0)3-3447-7637  
E-mail :ntt@ikonet.co.jp  
URL :http://www.ikont.co.jp/eg/  
Plant :Gifu, Kamakura

## NIPPON THOMPSON CO., LTD.

○ ASEAN REPRESENTATIVE OFFICE  
Level 8, #1 Silom Road, Silom, Bangrak, Bangkok  
Thailand 10500  
Phone: +66 (0)2-231-8278  
Fax: +66 (0)2-231-8121  
E-mail: ntar@ikonet.co.jp

## IKO-THOMPSON (SHANGHAI) LTD.

○ 1402-1404 Sunyoung Center  
28 Xuanhua Road, Shanghai  
People's Republic of China 200050  
Phone: +86 (0)21-3250-5525  
Fax: +86 (0)21-3250-5526  
E-mail: ntc@ikonet.co.jp

## IKO INTERNATIONAL, INC.

http://www.ikont.com/

### East coast

■ 91 Walsh Drive  
Parsippany, NJ 07054  
U.S.A.  
Phone: +1 973-402-0254  
Toll Free: 1-800-922-0337  
Fax: +1 973-402-0441  
E-mail: eco@ikonet.co.jp

### Midwest

○ 500 East Thorndale Avenue  
Wood Dale, IL 60191  
U.S.A.  
Phone: +1 630-766-6464  
Toll Free: 1-800-323-6694  
Fax: +1 630-766-6869  
E-mail: mwo@ikonet.co.jp

### West coast

○ 20170 South Western Avenue  
Torrance, CA 90501  
U.S.A.  
Phone: +1 310-609-3988  
Toll Free: 1-800-252-3665  
Fax: +1 310-609-3916  
E-mail: wco@ikonet.co.jp

### Southeast

○ 2150 Boggs Road, Suite 100  
Duluth, GA 30096  
U.S.A.  
Phone: +1 770-418-1904  
Toll Free: 1-800-874-6445  
Fax: +1 770-418-9403  
E-mail: seo@ikonet.co.jp

### Southwest

○ 8105 N. Beltline Road  
Suite 130, Irving, TX 75063  
U.S.A.  
Phone: +1 972-929-1515  
Toll Free: 1-800-295-7886  
Fax: +1 972-915-0060  
E-mail: swo@ikonet.co.jp

## NIPPON THOMPSON EUROPE B.V.

http://www.ikont.eu/

### The Netherlands

■ Sheffieldstraat 35-39  
3047 AN Rotterdam  
The Netherlands  
Phone: +31 (0)10-4626868  
Fax: +31 (0)10-4626099  
E-mail: nte@ikonet.co.jp

### Germany

○ Mündelheimer Weg 56  
40472 Düsseldorf  
Germany  
Phone: +49 (0)211-414061  
Fax: +49 (0)211-427693  
E-mail: ntd@ikonet.co.jp

Im Gewerbepark D 30  
93059 Regensburg  
Germany  
Phone: +49 (0)941-206070  
Fax: +49 (0)941-2060719  
E-mail: ntdr@iko-nt.de

Gruben Str.95c  
66540 Neunkirchen  
Germany  
Phone: +49 (0)6821-999-860  
Fax: +49 (0)6821-999-8626  
E-mail: ntdn@iko-nt.de

### UK

○ 2 Vincent Avenue, Crownhill  
Milton Keynes Bucks MK8 0AB  
United Kingdom  
Phone: +44 (0)1908-566144  
Fax: +44 (0)1908-565458  
E-mail: sales@iko.co.uk

### Spain

○ Autovia Madrid-Barcelona, Km. 43,700  
Polig. Ind. AIDA, A-8, Ofic. 2, 1ª  
19200-Azuqueca de Henares  
Guadalajara, Spain  
Phone: +34 949-263390  
Fax: +34 949-263113  
E-mail: nts@ikonet.co.jp

### France

○ Roissypole Le Dôme  
2 rue de La Haye  
BP 15950 Tremblay en France  
95733 Roissy C. D. G. Cedex  
France  
Phone: +33 (0)1-48165739  
Fax: +33 (0)1-48165746  
E-mail: ntf@ikonet.co.jp

## Overseas Subsidiary Companies



- Headquarters
- Branches
- Sales Offices
- Distributors